

EATON | Aerospace

Electric Distribution & Controls

Switch Catalog



Table of Contents

3	Table of Contents
4	Descriptive Index
5	Fast Information Finder
5	Part Number to Page Index
	<u>Capabilities and Featured Products</u>
6 - 7	Organizational Capabilities
8 - 9	Featured Product Articles
10	Notes
A1 - A76	Toggle Switches
B1 - B26	Pushbutton Switches
C1 - C32	Rocker Switches
D1 - D6	Precision Snap Action Switches
E1 - E4	Sealed Limit Switches
F1 - F8	Switch Guards & Shields
G1 - G8	Accessories
H1 - H12	Reference

Capabilities and Featured Products

Toggle Switches

Pushbutton Switches

Rocker Switches

Precision Snap Action Switches

Sealed Limit Switches

Switch Guards & Shields

Accessories

Reference

Descriptive Index







Accessories	G1 - G5	Rocker Switches	
		Econo Switch Sealed Rocker Switches	C9 - C18
Cross Reference		"Illuminator" Series Rocker Switches	C2- C8
Part Number to Page Index	5	Removable Button (RB Series)	C9 - C12
Military P/N to Eaton P/N	H2 - H7	Rocker Switches	
Test Requirements per MIL Specs	H8 - H9		
Glossary of Terms	H10 - H12	Switch Guards & Shields	F1 - F8
Capabilities	6 - 7	Toggle Switches	
EMI/RFI Shielded Pushbutton Switches	B14 - B19	Designerline Toggle Switches	A8 -A10
Environmentally Sealed Switches		Environmentally Sealed Toggle Switches	A2 - A34, A38 - A47
Environmentally Sealed Rocker Switches	C-9 - C-31	Environmentally Sealed Toggle Switches with Integrated Wire Terminal Systems (IWTS)	A27 - A34, A60 -A62
Environmentally Sealed Toggle Switches	A2 - A34	Environmentally Sealed Positive Action Switches	A38 - A47
Limit Switches	E1 - E3	High Capacity Toggle Switches	A68 - A69
Hermetic Switches	E4	Integral Toggle Switches	A67
MIL-S-3950 Environmentally Sealed Toggle Switches	A20 - A34	MIL-S-8805 Toggle Switches	A35 - A37
		MIL-S-3950 Toggle Switches	A20 - A34
		MIL-S-8834 Toggle Switches	A38 - A62
		Multi-Circuit Toggle Switches	A35 - A37
		Econoswitch Line	A11 - A19
Miniature Switches			
MIL-S-8834 Miniature Positive Action	A48 - A62		
Four-Pole Miniature Positive Action Toggle	A63 - A66		
Miniature Switches with Integrated Wire Termination System (IWTS)	A60 - A62		
Miniature Integral Toggle Switches	A67		
Precision Snap Action Switches			
Basic Snap Switches	D2 - D4		
Roller, Straight, and Leaf Actuator	D5		
Pushbutton Switches			
Illuminated Pushbutton Switches	B20		
Sub-Miniature Pushbutton Switches	B18 - B19		
Pistol Grip Pushbutton Switches	B21 - B23		
Special Designed Pushbuttons	B24 - B25		
Standard Pushbutton Switches	B2 - B14		
Uniform Panel Appearance (UPA) Pushbutton Switches	B15 - B17		

Fast Information Finder

- Have an Eaton part number and need more information?** Use the part number to page index on this page to get the exact page of the full product listing.
- Have a Military part number and need the applicable Eaton part number?** Use the Military Part Number Index in the back of this catalog.
- Know the type of product you want, but not a specific part number?** Use the detailed index on the facing page to find the section with those products.
- Need additional information not contained in this catalog?** For technical questions, application assistance, or the name of your local authorized distributor, call 1- 800-955-7354.

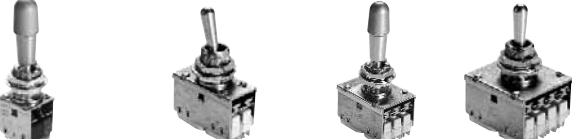
Part Number to Page Index

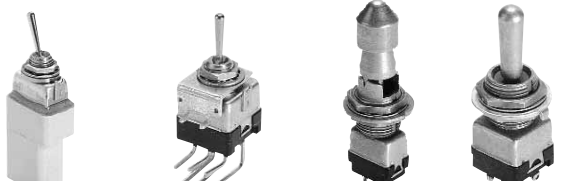
Eaton Part No.	Page No.	Eaton Part No.	Page No.
15-	G2 - G3	A2-	D5
16-	G3	A20000	B20
24-	G2	A3-200 - A3-215	A35
29-	G2	A5-	D5
32-	G1	B-	C4
49-	G1 - G2	B7070	B19
52-	G3 - G5	B9001	B18
73-	F7	B9021 - B9022	B18
80-	G3 - G5	BR7070	B19
815-	G3	C100	B15
821-	G3	C4100	B15
8492 - 8499	F2	C20050	B8
8500 - 8502	A20	D4-	D2
8503 - 8505	A23	D8-	D2
8510 - 8512	A2	D201 - D207	B2
8520 - 8528	A5	E4-	D2
8530 - 8532	A11	EF-	D2
8533 - 8535	A17	EM-	D2
8536 - 8538	A14	G3-	D2
8540 - 8542	C19	H11-	E2
8543 - 8545	C22	H2200	B4
8546 - 8548	C24	HH-	E4
8551 - 8553	C9	J100	B10
8554 - 8556	C13	J300	B6
8566 - 8568	A8	J4004	B9
8570 - 8572	A27	J20000	B20
8573 - 8575	A30	K3-	D2
8780 - 8782	A68	R00B1 - R00B5	C5
8790 - 8792	A68	S1-	D2
8836 - 8838	A38	S2-	D2
8836KP - 8838KP	A46	S3-	D2
8843 - 8845	A43	T-	A67
8854	A63	TW-	A67
8855 - 8856	A57	W100	B15
8864	F8	W300	B11
8866 - 8869	A48	W403P6	B17
8870	B24	W1501	B17
8879	A65	W9000	B12
8895 - 8897	B21	W9600	B13
8899	B21	W9623	B14
8909	B24	WC150	B15
A-	C4		

	Index	A1
	Industrial - Environmentally Sealed Switches <ul style="list-style-type: none"> • Watertight seal per MIL-STD-108 • Ratings at 28VDC and 115VAC 60/400Hz • One, two and four pole configurations • Toggle, lever lock and designerline Actuator • Positive detent action • Multi-circuit variations offered 	A2 – A10
	Econoswitch - Environmentally Sealed Switches <ul style="list-style-type: none"> • Watertight seal per MIL-STD-108 • Ratings at 28VDC and 115VAC 60/400Hz • One, two and four pole configurations • Patented base compression seal • Toggle, lever lock and designerline Actuator • Terminal variations - screw, spade and solder lug 	A11 – A19
	Military - Environmentally Sealed Switches <ul style="list-style-type: none"> • MS approved and QPL listed to MIL-S-3950 • One, two and four pole configurations • Terminal variations - screw and IWTS • Toggle and lever lock Actuator • Positive detent action 	A20 – A34
	Multi-Circuit Switches <ul style="list-style-type: none"> • Ratings up to 7 amperes • Two, four, six and eight pole configurations • Lever lock or standard lever Actuator • Double turret terminals • One hold mounting 	A35 – A37
	Environmentally Sealed Positive Action Switches <ul style="list-style-type: none"> • Meets MIL-S-8834 requirements • Ratings at 28VDC and 115VAC, 60/400Hz • One, two and four pole configurations • Standard lever and lever lock Actuator • High reliability - Mechanical and electrical • Screw and solder lug 	A38 – A47
	Miniature Positive Action Switches <ul style="list-style-type: none"> • MS approved and QPL listed to MIL-S-8834 • Rating variation - power to logic levels • One and two pole configuration • Bushing sealed per MIL-S-8834 • Non-teasible mechanism • Toggle and lever lock Actuator • Terminal variations - solder lug, printed circuit and IWTS 	A48 – A66
	Miniature Integral Switches <ul style="list-style-type: none"> • Ratings up to 20 amperes • One and two pole configurations • Choice of terminals • Maintained contacts • One hold mounting 	A67
	High Capacity Switches <ul style="list-style-type: none"> • High current capability at 28VDC and 115VAC 60 Hz • One and three pole arrangements • Positive detent action • Flush mounted • Large toggle Actuator 	A68 – A69

Ratings and Switch Position Diagrams
A70 – A75

*Most items listed in this catalog are standard products and are normally in Distributor Inventory; however, the current inventory status should be checked by contacting your Eaton Customer Service Representative at 800-955-7354 or your authorized Distributor before placing orders.

INDUSTRIAL - ENVIRONMENTALLY SEALED SWITCHES

Series - 8510, 8511, 8512

Environmentally Sealed Toggle Switches

FEATURES

SPECIFICATIONS

CURRENT RATINGS

- Completely sealed against dust, moisture, and other contaminants
- 1, 2 and 4 pole circuitry
- One hole mounting for easy installation
- Multi-circuits offered
- 2 & 3 position with maintained and momentary action
- Molded-in terminal inserts
- Molded-in terminal numbers
- See 8520-8528 for UL recognized and CSA certified version on page A5.

- Water tight seal per MIL-STD-108E and designed to meet IP68
- Thermoset molding materials meet flame retardant requirements
- Temperature Range: -50°F to +150°F (-46°C to +66°C)
- Life: 20,000 operations at rated load
- Bushing: 15/32" - 32 thread

No. of Poles	Catalog Number	Type of Operation	28VDC			115 VAC 60 or 400Hz		
			Lamp Load	Resistive Load	Inductive Load	Lamp Load	Resistive Load	Inductive Load
1	8510	Maintained	5	20	15	3	15	10
		Momentary	4	15	10	2	15	7
2	8511	Maintained	7	20	15	4	15	15
		Momentary	5	18	10	2	11	8
4	8512	Maintained	5	20	12	4	15	15
		Momentary	4	18	10	2	11	8

SELECTION TABLE

FLUSH TERMINAL SCREWS



8510



8511



8512

CIRCUIT WITH LEVER IN . . .			ONE POLE	TWO POLE	FOUR POLE
Up Position	Center Position	Down Position (Keyway)	Catalog Number	Catalog Number	Catalog Number
			8510K1	8511K1	8512K1
ON	OFF	ON	K9	K9	K9
ON	NONE	OFF	K4	K4	K4
ON	NONE	ON	K6	K6	K6
ON	OFF*	NONE	K8	K8	K8
ON	NONE	NONE	8510K5	8511K5	8512K5
* ON	OFF	ON*	K2	K2	K2
NONE	OFF	ON*	K7	K7	K7
ON	NONE	OFF*	K10	K10	K10
OFF	NONE	ON*	K11	K11	K11
ON	OFF	ON*	8510K3	8511K3	8512K3
* ON	ON	NONE	K12	K12	K12
ON	ON	NONE	K13	K13	K13
ON	ON	ON	—	8511K14	8512K15
ON	ON	ON*	—	K15	K16
* ON	ON	ON*	—	K16	K17
ON	ON	ON	—	8511K17	—
ON	ON	ON*	—	K18	—
* ON	ON	ON*	—	K19	—

* Momentary contact.

See Page A71 for circuit diagrams.

MOUNTING DIMENSIONS - ONE POLE / 8510

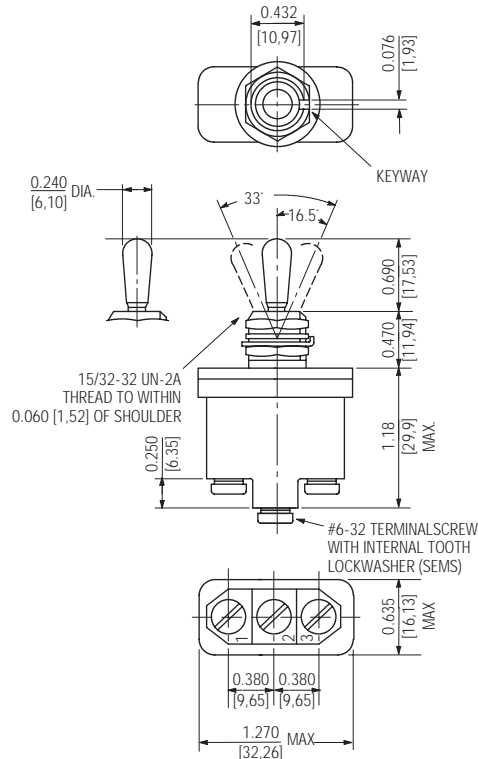

Terminal Identification

MOUNTING DIMENSIONS - TWO POLE / 8511

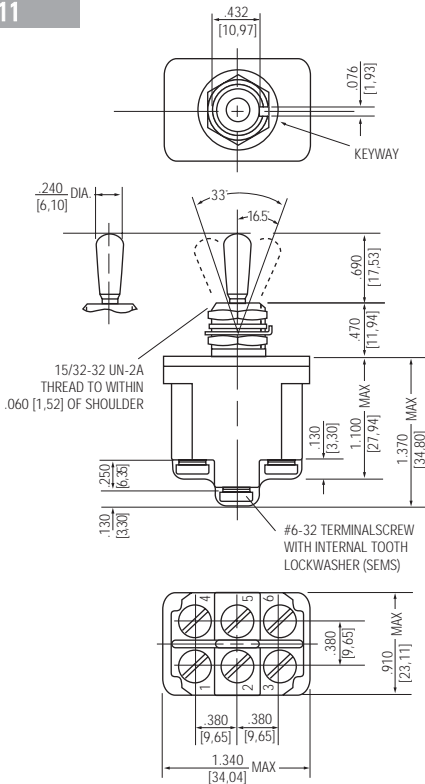

Terminal Identification

STANDARD

0.00 = inches

[0,0] = mm

Mounting dimensions for reference only.

Non-functional terminals not supplied.

INDUSTRIAL - ENVIRONMENTALLY SEALED SWITCHES

Series - 8510, 8511, 8512

Environmentally Sealed Toggle Switches

MOUNTING DIMENSIONS - FOUR POLE / 8512

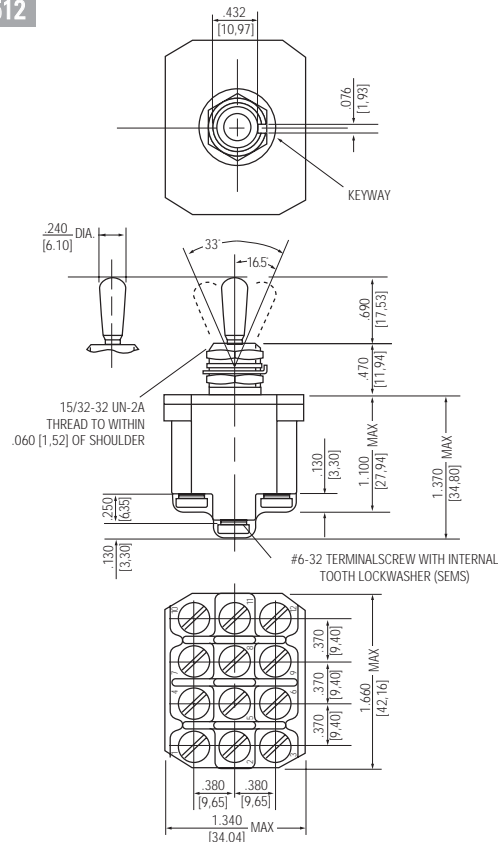

Terminal Identification

OPTIONS/ACCESSORIES

PANEL CUTOUT DIMENSIONS

- Special mounting hardware
- Mounting hardware furnished assembled
- Terminal screws furnished assembled
- Special toggle levers
- Special circuits
- Panel seal, Part Number 32-341
- Spade terminal adapters available

15/32 DIA. BUSHING

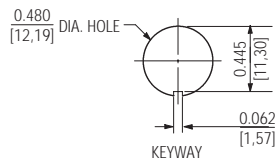
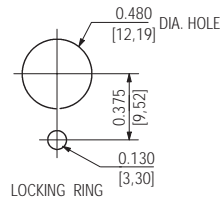

STANDARD

0.00 = inches

[0,0] = mm

Mounting dimensions for reference only.

Non-functional terminals not supplied.

INDUSTRIAL - ENVIRONMENTALLY SEALED SWITCHES

Series - 8520-8522, 8526-8528

Environmentally Sealed Toggle Switches
UL Recognized and CSA Certified

FEATURES	SPECIFICATIONS	CURRENT RATINGS					
		Amperes		Maximum Horsepower			
<ul style="list-style-type: none"> Completely sealed against dust, moisture, and other contaminants UL and CSA approved One hole mounted bushing for easy installation Multi-circuits offered 2 & 3 position with maintained and momentary action Molded-in terminal inserts and terminal numbers 1, 2 and 4 pole circuitry 	<ul style="list-style-type: none"> Watertight seal per MIL-STD-108E and designed to meet IP68 Thermoset molding materials meet flame retardant requirements UL recognized and CSA certified per specifications listed below Temperature Range: -50°F to +150°F (-46°C to +66°C) Life: 20,000 operations at rated load 40,000 operations mechanical life 6,000 operations at HP ratings per UL and CSA requirements Bushing: 15/32" - 32 thread 			1 Phase		3 Phase	
		125V	250V	125VAC	250VAC	125/250 VAC	
		8520	18	9	1/4	1/2	—
		8521	18	9	1/2	1	—
		8522	18	9	1/2	1	1
		8526 thru 8528	18	9	—	—	—

SELECTION TABLE

FLUSH TERMINAL SCREWS



8520/8526



8521/8527



8522/8528

CIRCUIT WITH LEVER IN . . .			ONE POLE	TWO POLE	FOUR POLE
Up Position	Center Position	Down Position (Keyway)	Catalog Number	Catalog Number	Catalog Number
			8520K1	8521K1	8522K1
ON	OFF	ON	K9	K9	K9
ON	NONE	OFF	K4	K4	K4
ON	NONE	ON*	8526K5	8527K5	8528K5
ON	OFF	ON	K2	K2	K2
ON	OFF	ON*	8526K3	8527K3	8528K3

*** Momentary contact.**

See page A71 for circuit diagrams.

UL & CSA Approval Numbers

UL - Where devices are UL recognized, recognition is listed under file number E15346; Guide card number is WOYR2.

CSA = Where devices are CSA certified, certification number is LR40068, class number 6241.

INDUSTRIAL - ENVIRONMENTALLY SEALED SWITCHES

Series - 8520-8522, 8526-8528

Environmentally Sealed Toggle Switches
UL Recognized and CSA Certified

MOUNTING DIMENSIONS - ONE POLE / 8520, 8526

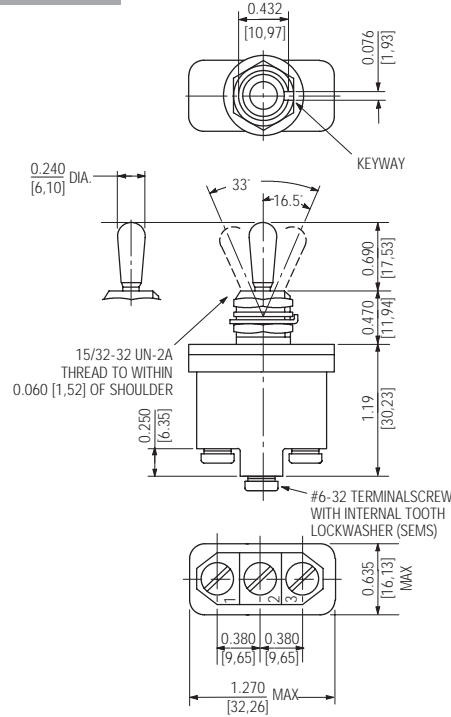

Terminal Identification

MOUNTING DIMENSIONS - TWO POLE / 8521, 8527

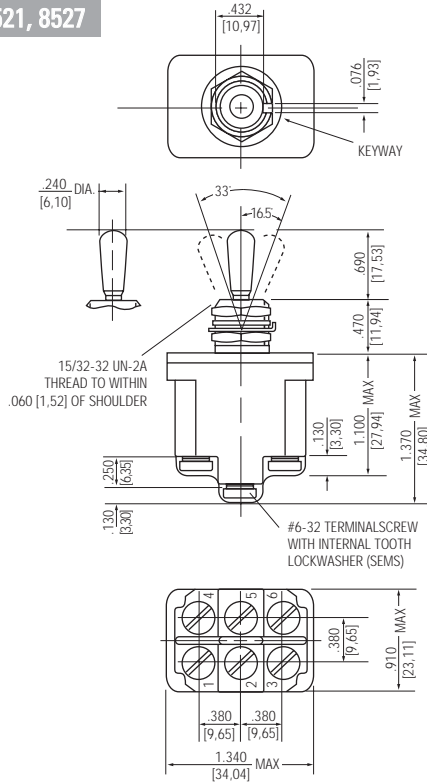

Terminal Identification

STANDARD

0.00 = inches

[0,0] = mm

Mounting dimensions for reference only.

Non-functional terminals not supplied.

INDUSTRIAL - ENVIRONMENTALLY SEALED SWITCHES

Series - 8566, 8567, 8568

Environmentally Sealed Designerline Toggle Switches

FEATURES	SPECIFICATIONS	CURRENT RATINGS								
		No. of Poles	Catalog Number	Type of Operation	28VDC			115 VAC 60 or 400Hz		
<ul style="list-style-type: none"> Completely sealed against dust, moisture, and other contaminants Variety of lever styles and colors One hole mounting for easy installation 2 & 3 position with maintained and momentary action 1, 2 and 4 pole circuitry Molded-in terminal inserts and terminal numbers Color-coded shaped levers for operator feel and cosmetic appearance 	<ul style="list-style-type: none"> Watertight seal per MIL-STD-108E and designed to meet IP68 Bushing: 15/32" - 32 thread Temperature Range: -50°F to +150°F (-46°C to +66°C) Life: 20,000 operations at rated load 40,000 operations mechanical life Thermoset molding materials meet flame retardant requirements 				Lamp Load	Resistive Load	Inductive Load	Lamp Load	Resistive Load	Inductive Load
		1	8566	Maintained Momentary	5	20	15	3	15	10
					4	15	10	2	15	7
		2	8567	Maintained Momentary	7	20	15	4	15	15
					5	18	10	2	11	8
		4	8568	Maintained Momentary	5	20	12	4	15	15
					4	18	10	2	11	8

FLUSH SCREW TERMINALS

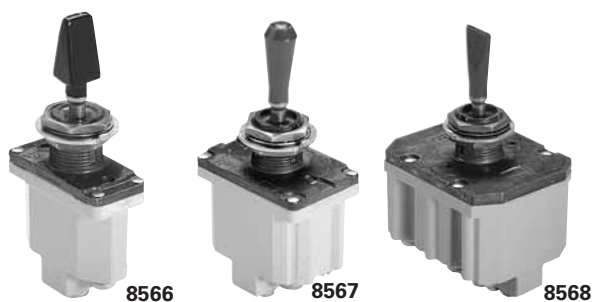

CIRCUIT WITH LEVER IN . . .			ONE POLE	TWO POLE	FOUR POLE	LEVER SUFFIXES ¹		
Up Position	Center Position	Down Position (Keyway)	Catalog Number	Catalog Number	Catalog Number	Shape [®] Suffix	Color Letter	Suffix Number
			8566K1	8567K1	8568K1			
ON	OFF	ON	K9	K9	K9			
ON	NONE	OFF	K4	K4	K4			
ON	NONE	ON	K6	K6	K6	All	White	21
ON	OFF	NONE	K8	K8	K8			
ON	OFF*	NONE	K8	K8	K8			
ON	NONE	ON*	8566K5	8567K5	8568K5			
* ON	OFF	ON*	K2	K2	K2			
NONE	OFF	ON*	K7	K7	K7			
ON	NONE	OFF*	K10	K10	K10	All	Red	22
OFF	NONE	ON*	K11	K11	K11			
ON	OFF	ON*	8566K3	8567K3	8568K3			
* ON	ON	NONE	K12	K12	K12			
ON	ON	NONE	K13	K13	K13			
ON	ON	ON	—	8567K14	8568K15	All	Black	27
ON	ON	ON*	—	K15	K16			
* ON	ON	ON*	—	K16	K17			
ON	ON	ON	—	8567K17	—			
ON	ON	ON*	—	K18	—			
* ON	ON	ON*	—	K19	—			

* Momentary contact.

See page A71 for circuit diagrams.

① A complete catalog number consists of a basic switch number followed by a lever shape suffix letter and a two-digit lever color suffix number. Example: 8566K1C21.

② Select lever shape suffix letter from page A10.

MOUNTING DIMENSIONS - ONE POLE / 8566

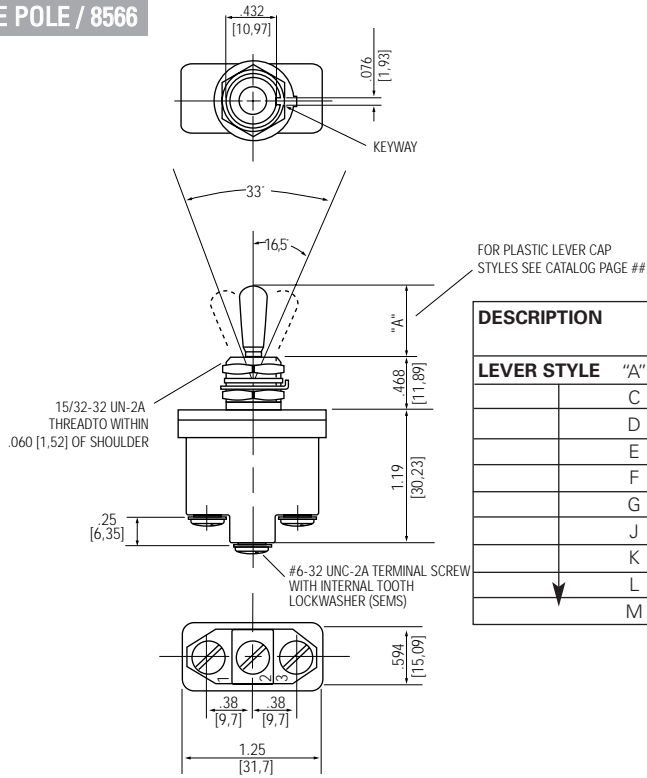

DESCRIPTION	DIM. "A" INCHES	DIM. "A" METRIC
LEVER STYLE "A"	.938	23,83
C	.859	21,82
D	.893	22,68
E	.893	22,68
F	1.021	25,93
G	.953	24,21
J	.950	24,13
K	.950	24,13
L	.950	24,13
M	1.150	29,21

Terminal Identification

MOUNTING DIMENSIONS - TWO POLE / 8567

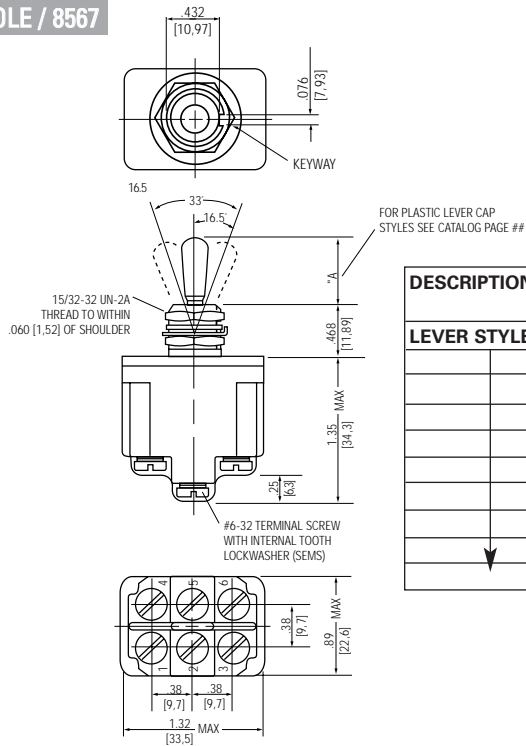

DESCRIPTION	DIM. "A" INCHES	DIM. "A" METRIC
LEVER STYLE "A"	.938	23,83
C	.859	21,82
D	.893	22,68
E	.893	22,68
F	1.021	25,93
G	.953	24,21
J	.950	24,13
K	.950	24,13
L	.950	24,13
M	1.150	29,21

Terminal Identification

STANDARD
0.00 = inches
[0,0] = mm

Mounting dimensions for reference only.

Non-functional terminals not supplied.

INDUSTRIAL - ENVIRONMENTALLY SEALED SWITCHES

Series - 8566, 8567, 8568

Environmentally Sealed Designerline Toggle Switches

MOUNTING DIMENSIONS - FOUR POLE / 8568

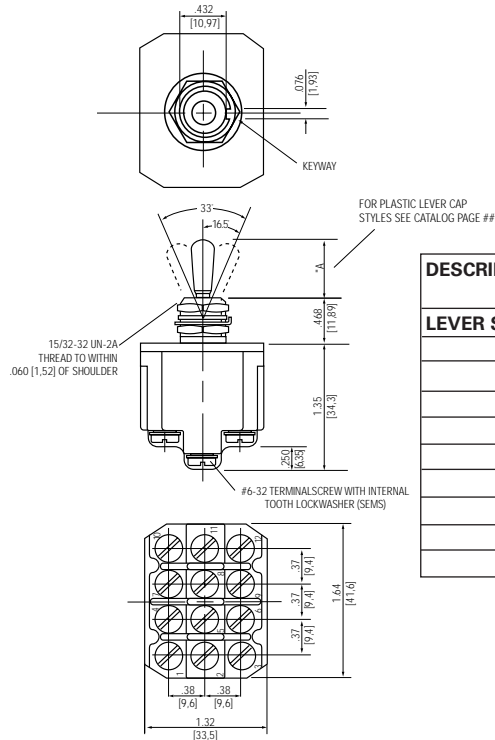

DESCRIPTION	DIM. "A"	DIM. "A"
LEVER STYLE	"A"	METRIC
A	.938	23,83
C	.859	21,82
D	.893	22,68
E	.893	22,68
F	1.021	25,93
G	.953	24,21
J	.950	24,13
K	.950	24,13
L	.950	24,13
M	1.150	29,21

Terminal Identification

Non-functional terminals not supplied.

OPTIONS/ACCESSORIES

- Standard colors available - White, red and black

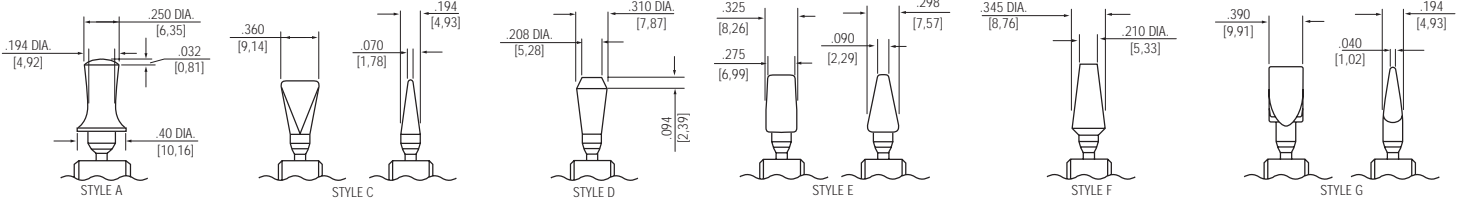

- Special mounting hardware
- Mounting hardware furnished assembled
- Terminal screws furnished assembled
- Spade terminal adapters available
- Panel seal, Part Number 32-341
- Special circuits

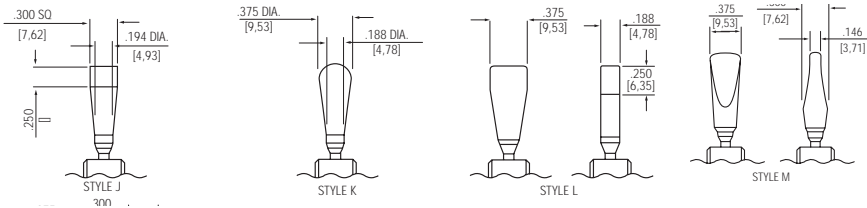

PANEL CUTOUT DIMENSIONS

15/32 DIA. BUSHING

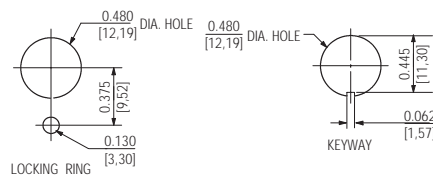

STANDARD

0.00 = inches

[0,0] = mm

Mounting dimensions for reference only.

INDUSTRIAL - ENVIRONMENTALLY SEALED SWITCHES

Series - 8530, 8531, 8532

Econoswitch Sealed Toggle Switches

FEATURES

- Environmentally sealed
- 1, 2 and 4 pole Circuitry
- One hole mounting for easy installation
- Multi-circuits
- 2 & 3 position with maintained and momentary action
- Three types of termination offered as standard

SPECIFICATIONS

- Watertight seal per MIL-STD-108E and designed to meet IP68
- UL recognized and CSA certified
- Three standard types of terminals:
 - Screw 6-32 UNC-2A
 - Solder lug .125 [3,17] dia. hole
 - Spade .250 [6,35] x .032 [0,81] thick
- Life: 50,000 operations at rated load. 100,000 operations mechanical life.
- Temperature Range: -50°F to +150°F (-46°C to + 66°C)

CURRENT RATINGS





No. of Poles	Catalog Number	Type of Operation	28VDC			115VAC 60 or 400Hz		
			Lamp Load	Resistive Load	Inductive Load	Lamp Load	Resistive Load	Inductive Load
1	8530	Maintained	5	20	15	3	15	10
		Momentary	4	15	10	2	11	7
2	8531	Maintained	7	20	15	4	15	15
		Momentary	5	18	10	2	11	8
4	8532	Maintained	5	20	12	4	15	15
		Momentary	4	18	10	2	11	8

For the UL/CSA ratings, see page A70.

STANDARD LEVER SELECTION TABLE

CIRCUIT WITH LEVER IN . . .

CATALOG NUMBER

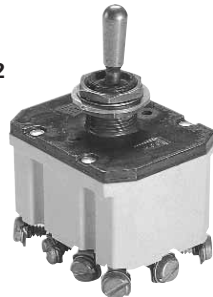
	Up Position 	Center Position 	Down Position (Keyway) 	Screw Terminals	Solder Lug Terminals	Spade Terminals
ONE POLE						
8530 	ON	OFF	ON	8530K1	8530K91	8530K31
	ON	NONE	OFF	K9	K99	K39
	ON	NONE	ON	K4	K94	K34
	ON	OFF	NONE	K6	K96	K36
	ON	OFF*	NONE	K8	K98	K38
	ON	NONE	ON*	8530K5	8530K95	8530K35
	ON*	OFF	ON*	K2	K92	K32
	NONE	OFF	ON*	K7	K97	K37
	ON	NONE	OFF*	K10	K910	K310
	OFF	NONE	ON*	K11	K911	K311
	ON	OFF	ON*	8530K3	8530K93	8530K33
	ON*	ON	NONE	K12	K912	K312
ON	ON	NONE	K13	K913	K313	
TWO POLE						
8531 	ON	OFF	ON	8531K1	8531K91	8531K31
	ON	NONE	OFF	K9	K99	K39
	ON	NONE	ON	K4	K94	K34
	ON	OFF	NONE	K6	K96	K36
	ON	OFF*	NONE	K8	K98	K38
	ON	NONE	ON*	8531K5	8531K95	8531K35
	ON*	OFF	ON*	K2	K92	K32
	NONE	OFF	ON*	K7	K97	K37
	ON	NONE	OFF*	K10	K910	K310
	OFF	NONE	ON*	K11	K911	K311
	ON	OFF	ON*	8531K3	8531K93	8531K33
	ON*	ON	NONE	K12	K912	K312
	ON	ON	NONE	K13	K913	K313
	ON	ON	ON	K14	K914	K314
	ON	ON	ON*	K15	K915	K315
	ON*	ON	ON*	8531K16	8531K916	8531K316
	ON	ON	ON	K17	K917	K317
	ON	ON	ON*	K18	K918	K318
ON*	ON	ON*	K19	K919	K319	
FOUR POLE						
8532 	ON	OFF	ON	8532K1	8532K91	8532K31
	ON	NONE	OFF	K9	K99	K39
	ON	NONE	ON	K4	K94	K34
	ON	OFF	NONE	K6	K96	K36
	ON	OFF*	NONE	K8	K98	K38
	ON	NONE	ON*	8532K5	8532K95	8532K35
	* ON	OFF	ON*	K2	K92	K32
	NONE	OFF	ON*	K7	K97	K37
	ON	NONE	OFF*	K10	K910	K310
	OFF	NONE	ON*	K11	K911	K311
	ON	OFF	ON*	8532K3	8532K93	8532K33
	* ON	ON	NONE	K12	K912	K312
	ON	ON	NONE	K13	K913	K313
	ON	ON	ON	K15	K915	K315
	ON	ON	ON*	K16	K916	K316
	* ON	ON	ON*	K17	K917	K317

* Momentary contact.
See page A71 for circuit diagrams.

ECONOSWITCH - ENVIRONMENTALLY SEALED SWITCHES

Series - 8530, 8531, 8532

Econoswitch Sealed Toggle Switches

MOUNTING DIMENSIONS - ONE POLE / 8530

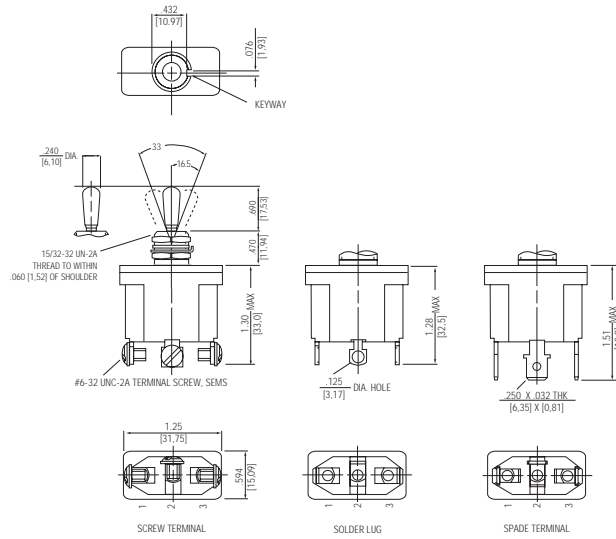

Terminal Identification

MOUNTING DIMENSIONS - TWO POLE / 8531

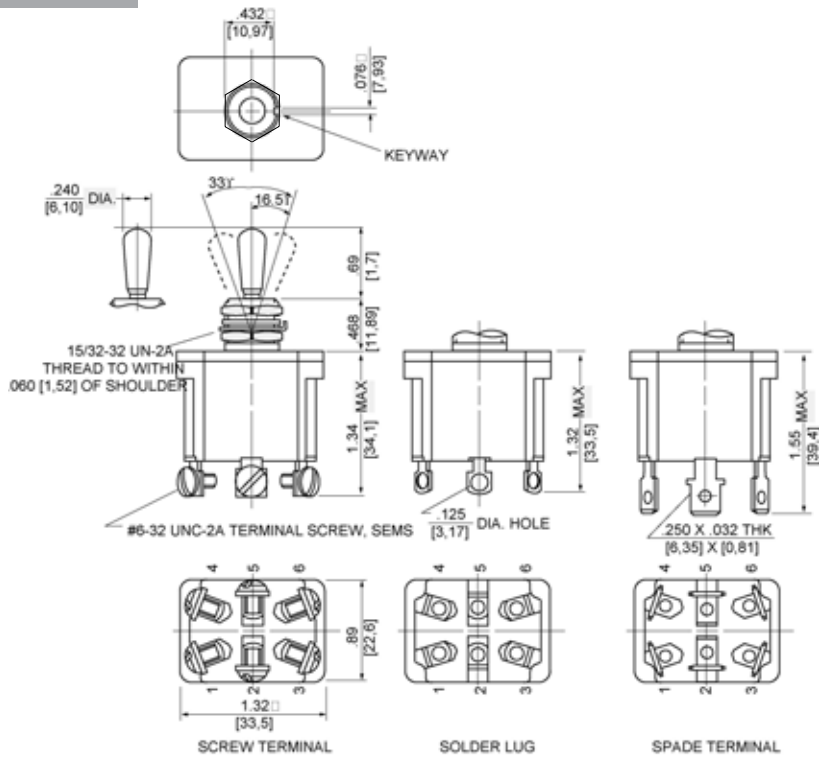

Terminal Identification

STANDARD

0.00 = inches

[0,0] = mm

Mounting dimensions for reference only.

Non-functional terminals not supplied.

MOUNTING DIMENSIONS - FOUR POLE/ 8532

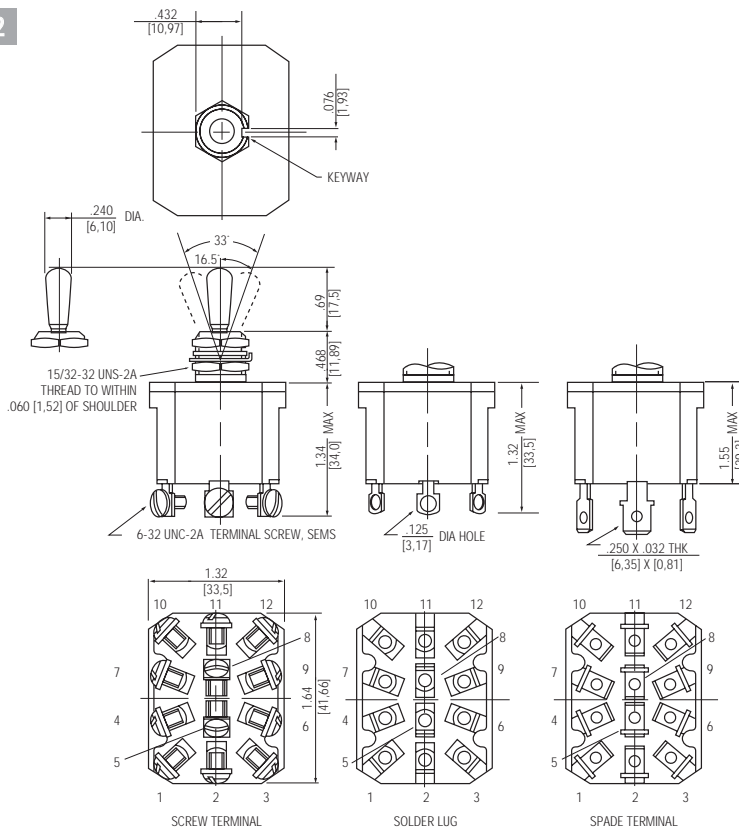

Terminal Identification

Non-functional terminals not supplied.

OPTIONS/ACCESSORIES

- Special mounting hardware
- Mounting hardware furnished assembled
- Terminal screws furnished assembled
- Special circuits
- Panel seal, Part Number 32-341
- Custom wire harnesses
- Mating connector available for two poles with spade terminal
- External jumpers available
 - bussing jumper
 - reversing jumpers

PANEL CUTOUT DIMENSIONS

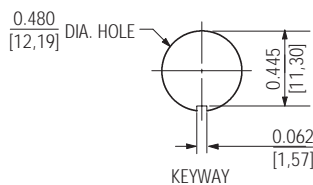
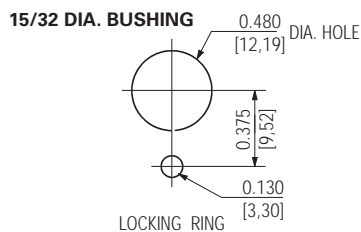

STANDARD

0.00 = inches

[0,0] = mm

Mounting dimensions for reference only.

ECONOSWITCH - ENVIRONMENTALLY SEALED SWITCHES

Series - 8536, 8537, 8538

Econoswitch Sealed Leverlock Toggle Switches

FEATURES

- Environmentally sealed
- 1, 2 and 4 pole circuitry
- Locking actuator for safety
- One hole mounting for easy installation
- Over 25 standard locking configurations
- 2 & 3 position with maintained and momentary action
- Multi-circuits
- Three types of termination offered as standard
- Also available with toggle and Designerline Actuator. For details see page A11 for toggles and page A17 for Designerline.

SPECIFICATIONS

- Watertight seal per MIL-STD-108E and designed to meet IP68
- UL recognized and CSA certified
- Temperature range: -50°F to +150°F (-46°C to +66°C)
- Life: 50,000 operations at rated load
100,000 operations mechanical life
- Bushing: 15/32" - 32 thread

CURRENT RATINGS







No. of Poles	Catalog Number	Type of Operation	28VDC			115VAC 60 or 400Hz		
			Lamp Load	Resistive Load	Inductive Load	Lamp Load	Resistive Load	Inductive Load
1	8536	Maintained Momentary	5	20	15	3	15	10
			4	15	10	2	15	7
2	8537	Maintained Momentary	7	20	15	4	15	15
			5	18	10	2	11	8
4	8538	Maintained Momentary	5	20	12	4	15	15
			4	18	10	2	11	8

For the UL/CSA ratings, see page A70.

LEVER LOCK SELECTION TABLE

CIRCUIT WITH LEVER IN . . .

CATALOG NUMBER

	Up Position 	Center Position 	Down Position (Keyway) 	Screw Terminals	Solder Lug Terminals	Spade Terminals	Available Locking Configurations
ONE POLE							
	ON	OFF	ON	8536K1 Δ	8536K91 Δ	8536K31 Δ	ALL
	ON	NONE	OFF	K9 Δ	K99 Δ	K39 Δ	D, F, G
	ON	NONE	ON	K4 Δ	K94 Δ	K34 Δ	D, F, G
	ON	OFF	NONE	K6 Δ	K96 Δ	K36 Δ	E, F, K, M
	ON	OFF*	NONE	K8 Δ	K98 Δ	K38 Δ	F
	ON	NONE	ON*	8536K5 Δ	8536K95 Δ	8536K35 Δ	F
	ON	OFF	ON	K2 Δ	K92 Δ	K32 Δ	E, L, N
	NONE	OFF	ON*	K7 Δ	K97 Δ	K37 Δ	E
	ON	NONE	OFF*	K10 Δ	K910 Δ	K310 Δ	F
	OFF	NONE	ON*	K11 Δ	K911 Δ	K311 Δ	F
	ON	OFF	ON*	8536K3 Δ	8536K93 Δ	8536K33 Δ	E, F, K, L, M, N
	*ON	ON	NONE	K12 Δ	K912 Δ	K312 Δ	E
ON	ON	NONE	K13 Δ	K913 Δ	K313 Δ	E, F, K, M	
TWO POLE							
	ON	OFF	ON	8537K1 Δ	8537K91 Δ	8537K31 Δ	ALL
	ON	NONE	OFF	K9 Δ	K99 Δ	K39 Δ	D, F, G
	ON	NONE	ON	K4 Δ	K94 Δ	K34 Δ	D, F, G
	ON	OFF	NONE	K6 Δ	K96 Δ	K36 Δ	E, F, K, M
	ON	OFF*	NONE	K8 Δ	K98 Δ	K38 Δ	F
	ON	NONE	ON*	8537K5 Δ	8537K95 Δ	8537K35 Δ	F
	ON	OFF	ON	K2 Δ	K92 Δ	K32 Δ	E, L, N
	NONE	OFF	ON*	K7 Δ	K97 Δ	K37 Δ	E
	ON	NONE	OFF*	K10 Δ	K910 Δ	K310 Δ	F
	OFF	NONE	ON*	K11 Δ	K911 Δ	K311 Δ	F
	ON	OFF	ON*	8537K3 Δ	8537K93 Δ	8537K33 Δ	E, F, K, L, M, N
	*ON	ON	NONE	K12 Δ	K912 Δ	K312 Δ	E
ON	ON	NONE	K13 Δ	K913 Δ	K313 Δ	E, F, K, M	
ON	ON	ON	8537K14 Δ	8537K914 Δ	8537K314 Δ	ALL	
ON	ON	ON*	K15 Δ	K915 Δ	K315 Δ	E, F, K, L, M, N	
ON	ON	ON	K16 Δ	K916 Δ	K316 Δ	E, L, N	
ON	ON	ON	K19 Δ	K919 Δ	K319 Δ	E, L, N	
FOUR POLE							
	ON	OFF	ON	8538K1 Δ	8538K91 Δ	8532K31 Δ	ALL
	ON	NONE	OFF	K9 Δ	K99 Δ	K39 Δ	D, F, G
	ON	NONE	ON	K4 Δ	K94 Δ	K34 Δ	D, F, G
	ON	OFF	NONE	K6 Δ	K96 Δ	K36 Δ	E, F, K, M
	ON	OFF*	NONE	K8 Δ	K98 Δ	K38 Δ	F
	ON	NONE	ON*	8538K5 Δ	8538K95 Δ	8532K35 Δ	F
	ON	OFF	ON	K2 Δ	K92 Δ	K32 Δ	E, L, N
	NONE	OFF	ON*	K7 Δ	K97 Δ	K37 Δ	E
	ON	NONE	OFF*	K10 Δ	K910 Δ	K310 Δ	F
	OFF	NONE	ON*	K11 Δ	K911 Δ	K311 Δ	F
	ON	OFF	ON*	8538K3 Δ	8538K93 Δ	8532K33 Δ	E, F, K, L, M, N
	*ON	ON	NONE	K12 Δ	K912 Δ	K312 Δ	E
ON	ON	NONE	K13 Δ	K913 Δ	K313 Δ	E, F, K, M	
ON	ON	ON	8538K15 Δ	8538K915 Δ	K315 Δ	ALL	
ON	ON	ON*	K16 Δ	K916 Δ	K316 Δ	E, F, K, L, M, N	
ON	ON	ON	K17 Δ	K917 Δ	K317 Δ	E, L, N	
ON	ON	ON	K19 Δ	8537K919 Δ	8537K319 Δ	E, L, N	

* **Momentary contact.**

Δ Complete part number requires this symbol to be replaced with a locking configuration letter - selected from page A16.

Example: 8536K31Δ E 8536K31E
 Basic Switch Locking Style Complete Part Number

See Page A71 for circuit diagrams.

MOUNTING DIMENSIONS - ONE POLE / 8536

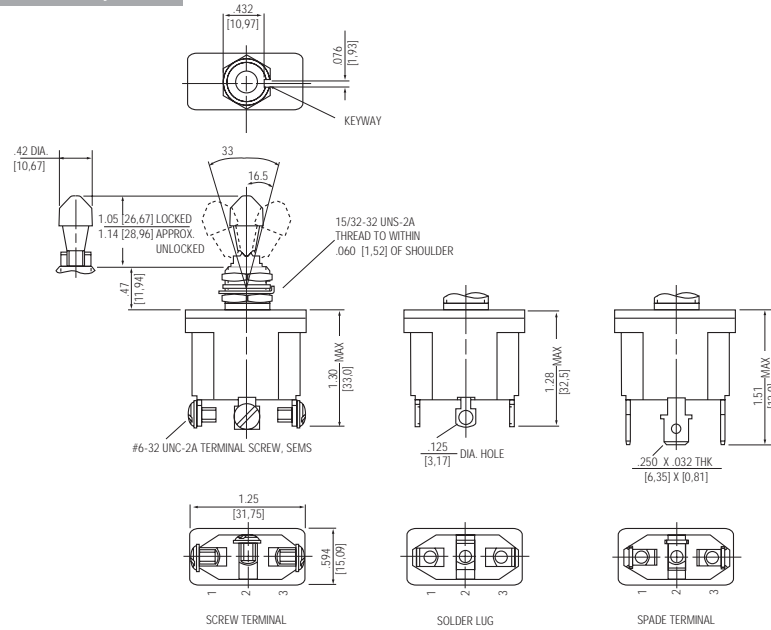

Terminal Identification

MOUNTING DIMENSIONS - TWO POLE / 8537

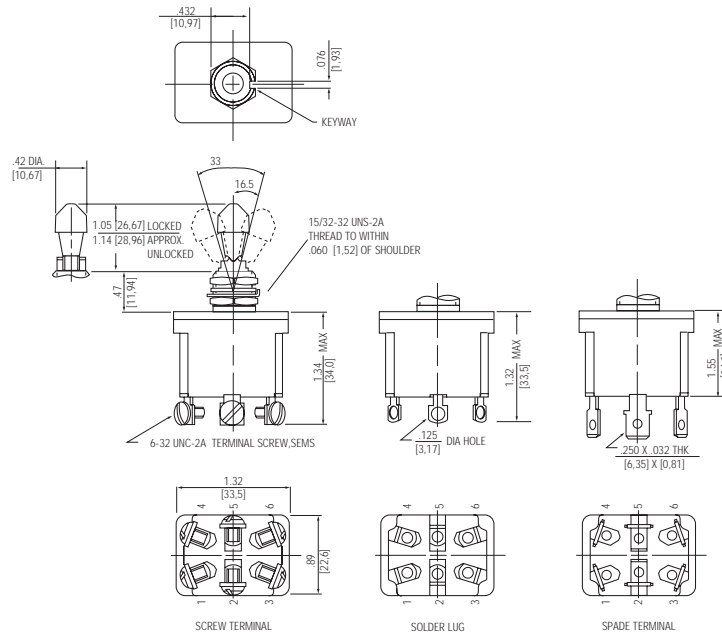

Terminal Identification

STANDARD
0.00 = inches
[0,0] = mm

Mounting dimensions for reference only.

Non-functional terminals not supplied.

ECONOSWITCH - ENVIRONMENTALLY SEALED SWITCHES

Series - 8536, 8537, 8538

Econoswitch Sealed Leverlock Toggle Switches

MOUNTING DIMENSIONS - FOUR POLE / 8538

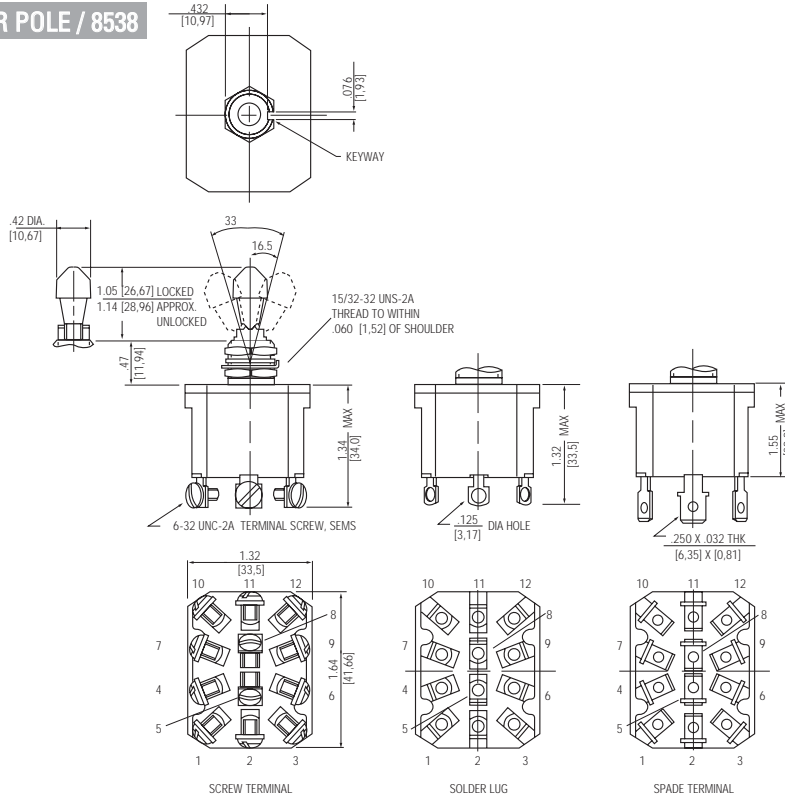

Terminal Identification

Non-functional terminals not supplied.

OPTIONS/ACCESSORIES

- Special mounting hardware
- Mounting hardware furnished assembled
- Terminal screws furnished assembled
- Special circuits
- Panel seals, Part Number 32-341

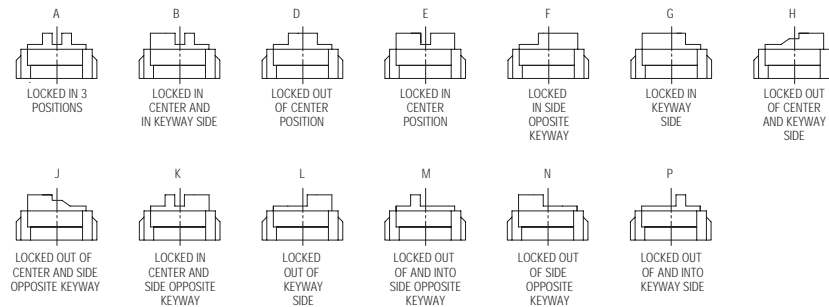

Figures A thru P do not represent details of construction. They schematically illustrate locking function.

PANEL CUTOUT DIMENSIONS

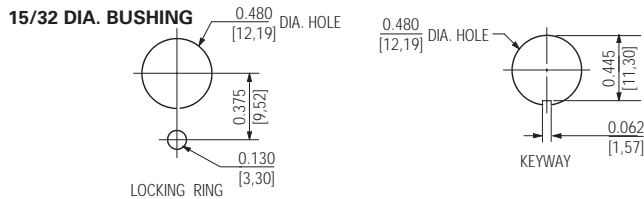

STANDARD

0.00 = inches

[0,0] = mm

Mounting dimensions for reference only.

ECONOSWITCH - ENVIRONMENTALLY SEALED SWITCHES







Series - 8533, 8534, 8535

Econoswitch Sealed Designerline Toggle Switches

FEATURES	SPECIFICATIONS	CURRENT RATINGS								
		No. of Poles	Catalog Number	Type of Operation	28VDC			115 VAC 60 or 400Hz		
					Lamp Load	Resistive Load	Inductive Load	Lamp Load	Resistive Load	Inductive Load
<ul style="list-style-type: none"> Environmentally sealed 1, 2 and 4 pole circuitry One hole mounting for easy installation Variety of lever styles and colors Color-coded, shaped levers for operator feel and cosmetic appearance 2 & 3 position with maintained and momentary action Three types of termination offered as standard Multi-circuits Also available with toggle and lever lock Actuator. For details, see page A11 for toggles and page A14 for lever locks. 	<ul style="list-style-type: none"> Watertight seal per MIL-STD-108E designed to meet IP68 UL recognized and CSA certified Bushing: 15/32" - 32 thread Temperature range: -50°F to +150°F (-46°C to +66°C) Life: 50,000 operations at rated load 100,000 operations mechanical life 	1	8533	Maintained	5	20	15	3	15	10
		1	8533	Momentary	4	15	10	2	11	7
		2	8534	Maintained	7	20	15	4	15	15
		2	8534	Momentary	5	18	10	2	11	8
		4	8535	Maintained	5	20	12	4	15	15
		4	8535	Momentary	4	18	10	2	11	8

For the UL/CSA ratings, see page A70.

SELECTION TABLE

	CIRCUIT WITH LEVER IN . . .			CATALOG NUMBER								
	Up Position	Center Position	Down Position (Keyway)	Screw Terminals ①	Solder Lug Terminals ①	Spade Terminals ①	Shape Suffix ②	Color Letter	Suffix Number			
												
 <p>8533</p>	ONE POLE			ON	OFF	ON	8533K1	8533K91	88533K31	All	White	21
	ON	NONE	OFF	K9	K99	K39						
	ON	NONE	ON	K4	K94	K34						
	ON	OFF	NONE	K6	K96	K36						
	ON	OFF	NONE	K8	K98	K38	All	Red	22			
	ON	NONE	ON*	8533K5	8533K95	8533K35						
	ON	OFF	ON*	K2	K92	K32						
	NONE	OFF	ON*	K7	K97	K37						
	ON	NONE	OFF*	K10	K910	K310	All	Black	27			
	OFF	NONE	ON*	K11	K911	K311						
	ON	OFF	ON*	8533K3	8533K93	8533K33						
	ON	ON	NONE	K12	K912	K312						
	ON	ON	NONE	K13	K913	K313						
 <p>8534</p>	TWO POLE			ON	OFF	ON	8534K1	8534K91	8534K31	All	White	21
	ON	NONE	OFF	K9	K99	K39						
	ON	NONE	ON	K4	K94	K34						
	ON	OFF	NONE	K6	K96	K36						
	ON	OFF	NONE	K8	K98	K38	All	Red	22			
	ON	NONE	ON*	8534K5	8534K95	8534K35						
	ON	OFF	ON*	K2	K92	K32						
	NONE	OFF	ON*	K7	K97	K37						
	ON	NONE	OFF*	K10	K910	K310	All	Black	27			
	OFF	NONE	ON*	K11	K911	K311						
	* ON	ON	NONE	8534K3	8534K93	8534K33						
	ON	ON	NONE	K12	K912	K312						
	ON	ON	NONE	K13	K913	K313						
 <p>8535</p>	FOUR POLE			ON	OFF	ON	8535K1	8535K91	8535K31	All	White	21
	ON	NONE	OFF	K9	K99	K39						
	ON	NONE	ON	K4	K94	K34						
	ON	OFF	NONE	K6	K96	K36						
	ON	OFF*	NONE	K8	K98	K38	All	Red	22			
	ON	NONE	ON*	8535K5	8535K95	8535K35						
	* ON	OFF	ON*	K2	K92	K32						
	NONE	OFF	ON*	K7	K97	K37						
	ON	NONE	OFF*	K10	K910	K310	All	Black	27			
	OFF	NONE	ON*	K11	K911	K311						
	* ON	ON	NONE	8535K3	8535K93	8535K33						
	ON	ON	NONE	K12	K912	K312						
	ON	ON	NONE	K13	K913	K313						
ON	ON	ON	8535K15	8535K915	8535K315							
ON	ON	ON*	K16	K916	K316							
* ON	ON	ON*	K17	K917	K317							

* Momentary contact.

① A complete catalog number consists of a basic switch number followed by a lever shape suffix letter and a two-digit lever color suffix number. Example: 8533K91E27.

See page A71 for circuit diagrams.

② Select lever shape suffix letter from page A19.

ECONOSWITCH - ENVIRONMENTALLY SEALED SWITCHES

Series - 8533, 8534, 8535

Econoswitch Sealed Designerline Toggle Switches

MOUNTING DIMENSIONS - ONE POLE / 8533

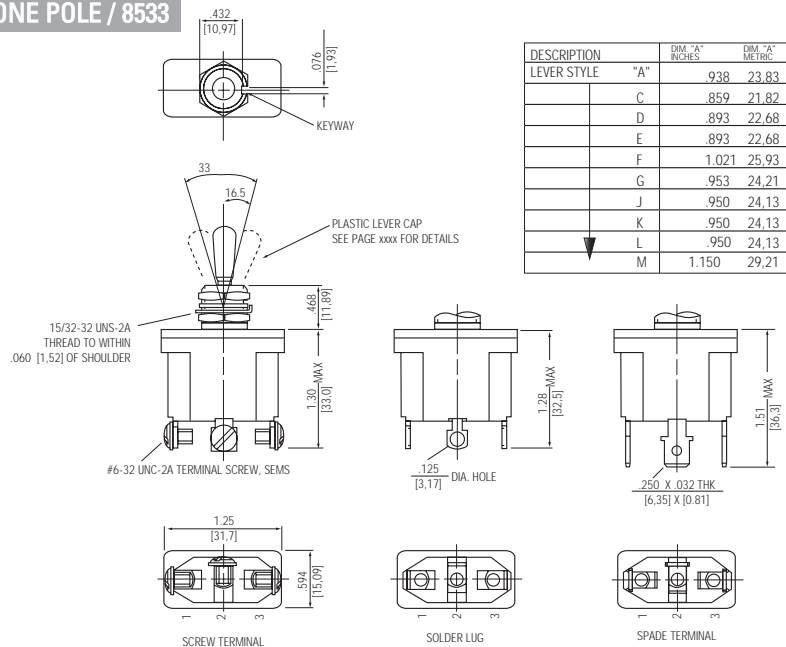

Terminal Identification

MOUNTING DIMENSIONS - TWO POLE / 8534

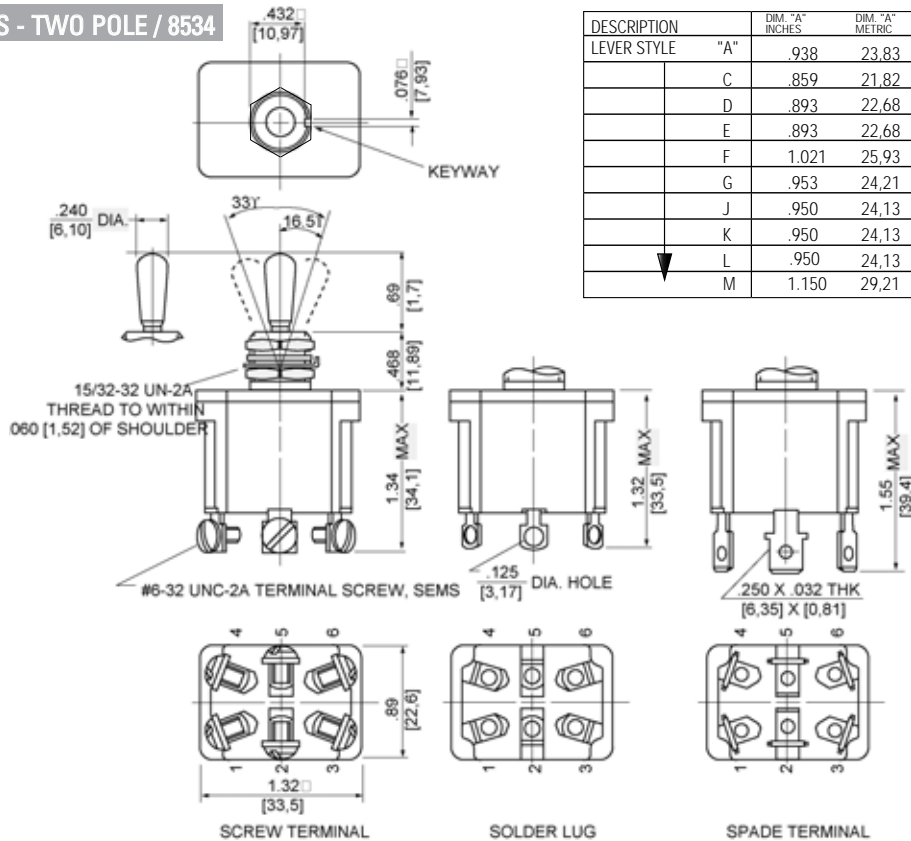

Terminal Identification

STANDARD

0.00 = inches

[0,0] = mm

Mounting dimensions for reference only.

Non-functional terminals not supplied.

ECONOSWITCH - ENVIRONMENTALLY SEALED SWITCHES

Series - 8533, 8534, 8535

Econoswitch Sealed Designerline Toggle Switches

MOUNTING DIMENSIONS - FOUR POLE / 8535

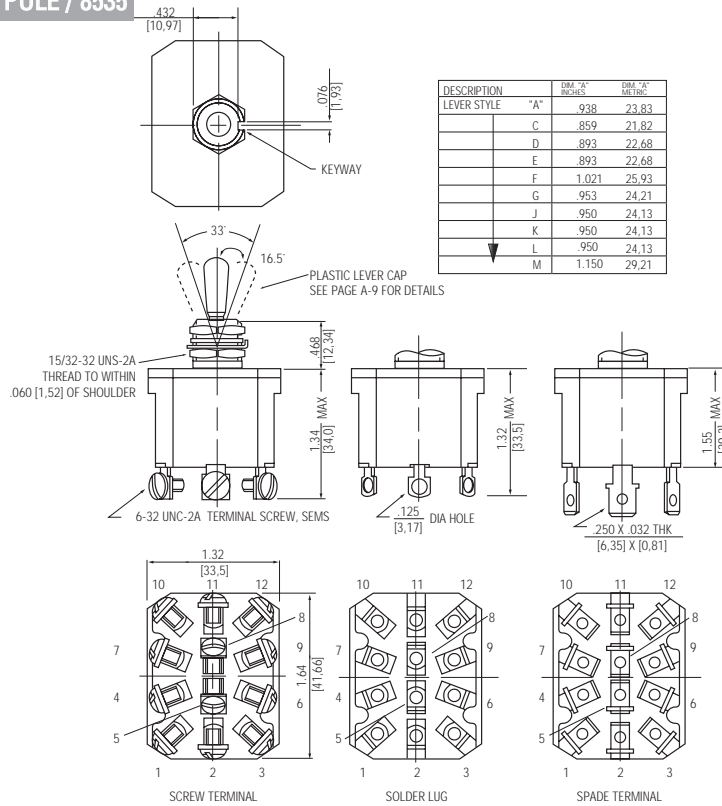

Terminal Identification

Non-functional terminals not supplied.

OPTIONS/ACCESSORIES

- Standard colors available - White, red and black

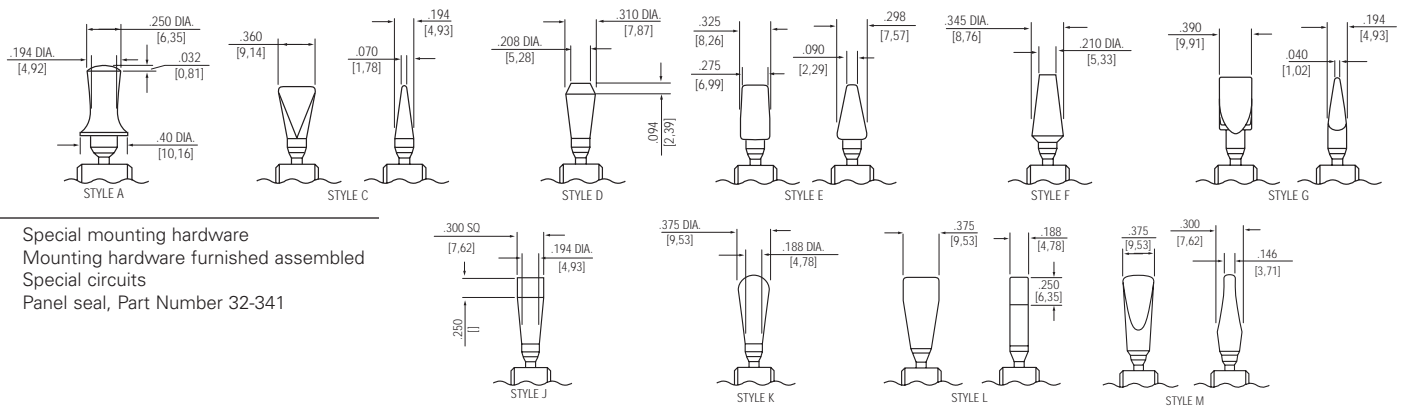

- Special mounting hardware
- Mounting hardware furnished assembled
- Special circuits
- Panel seal, Part Number 32-341

PANEL CUTOUT DIMENSIONS

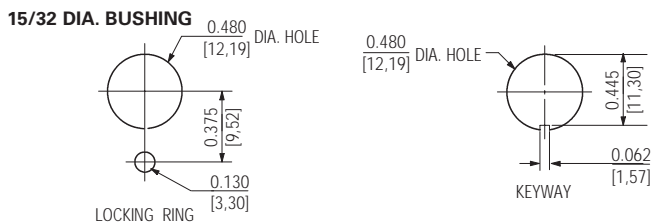

STANDARD

0.00 = inches

[0,0] = mm

Mounting dimensions for reference only.

MILITARY - ENVIRONMENTALLY SEALED SWITCHES

Series - 8500, 8501, 8502

MIL-S-3950 Toggle Switches

FEATURES

- Environmentally sealed
- 1, 2 and 4 pole circuitry
- 2 & 3 position with maintained and momentary action
- Molded-in terminal inserts and terminal numbers

SPECIFICATIONS

- Environmentally sealed per MILS-3950
- MS approved and QPL'd per MILS-3950
- Thermoset molding materials meet flame retardant requirements
- Bushing: 15/32" - 32 thread
- Temperature Range: -85°F to +160°F (-65°C to +71°C)
- Life: 20,000 operations at rated load
40,000 operations mechanical life

CURRENT RATINGS

No. of Poles	Catalog Number	Type of Operation	28VDC			115 VAC 60 or 400Hz		
			Lamp Load	Resistive Load	Inductive Load	Lamp Load	Resistive Load	Inductive Load
1	8500	Maintained	5	20	15	3	15	10
		Momentary	4	15	10	2	15	7
2	8501	Maintained	7	20	15	4	15	15
		Momentary	5	18	10	2	11	8
4	8502	Maintained	5	20	12	4	15	15
		Momentary	4	18	10	2	11	8

Minimum Rating: "Intermediate Current" per MILS-3950

STANDARD LEVER SELECTION TABLE



8500



8501



8502

CIRCUIT WITH LEVER IN . . .			ONE POLE		TWO POLE		FOUR POLE	
Up Position	Center Position	Down Position (Keyway)	MS Part Number	Catalog Number	MS Part Number	Catalog Number	MS Part Number	Catalog Number
ON	OFF	ON	MS24523-21	8500K1	MS24524-21	8501K1	MS24525-21	8502K1
ON	NONE	OFF	-22	K9	-22	K9	-22	K9
ON	NONE	ON	-23	K4	-23	K4	-23	K4
ON	OFF	NONE	-24	K6	-24	K6	-24	K6
ON	OFF*	NONE	-25	K8	-25	K8	-25	K8
ON	NONE	ON*	MS24523-26	8500K5	MS24524-26	8501K5	MS24525-26	8502K5
* ON	OFF	ON*	-27	K2	-27	K2	-27	K2
NONE	OFF	ON*	-28	K7	-28	K7	-28	K7
ON	NONE	OFF*	-29	K10	-29	K10	-29	K10
OFF	NONE	ON*	-30	K11	-30	K11	-30	K11
ON	OFF	ON*	MS24523-31	8500K3	MS24524-31	8501K3	MS24525-31	8502K3
* ON	ON	NONE	-32	K12	-32	K12	-32	K12
ON	ON	NONE	-33	K13	-33	K13	-33	K13
ON	ON	ON	—	—	MS27407-1	8501K14	MS27406-1	8502K15
ON	ON	ON*	—	—	-2	K15	-2	K16
* ON	ON	ON*	—	—	-3	K16	-3	K17
ON	ON	ON	—	—	-4	K17	—	—
ON	ON	ON*	—	—	-5	K18	—	—
* ON	ON	ON*	—	—	-6	K19	—	—

* Momentary contact.

See page A71 for circuit diagrams.

MOUNTING DIMENSIONS - ONE POLE / 8500

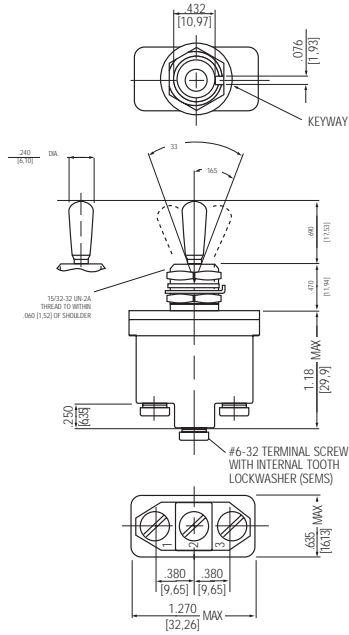

Terminal Identification

MOUNTING DIMENSIONS - TWO POLE / 8501

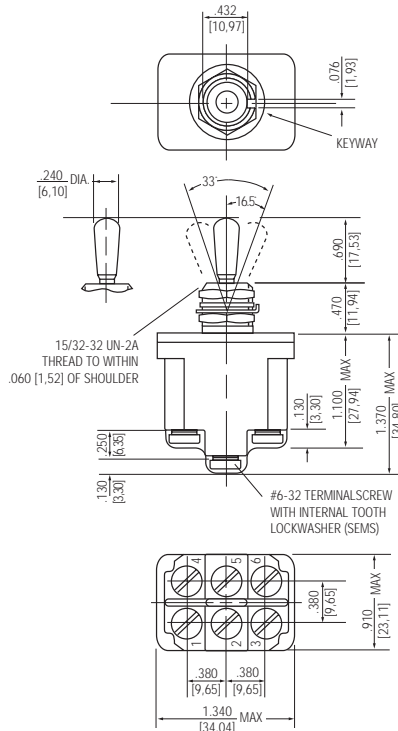

Terminal Identification

STANDARD
 0.00 = inches
 [0,0] = mm

Mounting dimensions for reference only.

Non-functional terminals not supplied.

MILITARY - ENVIRONMENTALLY SEALED SWITCHES

Series - 8500, 8501, 8502

MIL-S-3950 Toggle Switches

MOUNTING DIMENSIONS - FOUR POLE / 8502

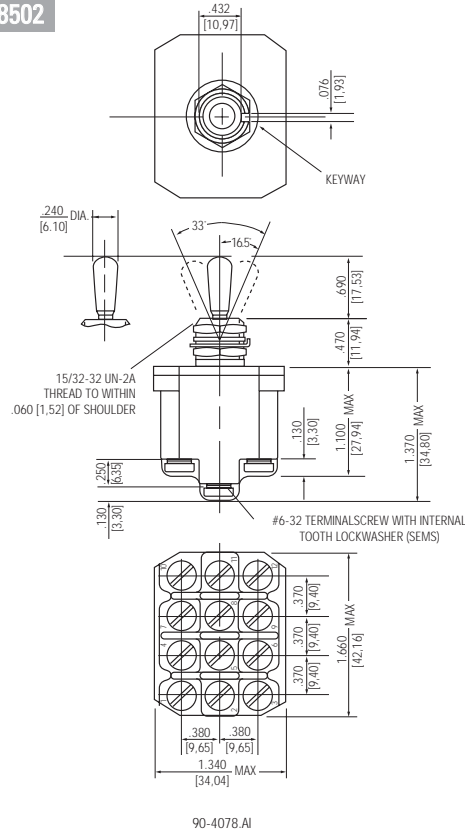

Terminal Identification

Non-functional terminals not supplied.

OPTIONS/ACCESSORIES

- Special mounting hardware
- Mounting hardware furnished assembled
- Terminal screws furnished assembled
- Special circuits
- Panel seal, part number 32-341 (See Accessories and Custom Components section)
- Special "3 Cateye" luminous lever attachment
- Lever extensions and attachable tips (See Accessories and Custom Components section)
- Custom wiring harnesses

PANEL CUTOUT DIMENSIONS

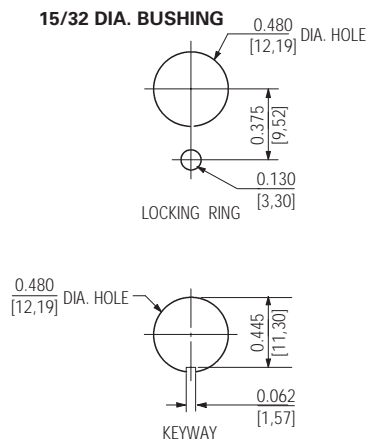

STANDARD

0.00 = inches

[0,0] = mm

Mounting dimensions for reference only.

MILITARY - ENVIRONMENTALLY SEALED SWITCHES

Series - 8503, 8504, 8505

MIL-S-3950 Lever Lock Switches

FEATURES

- Environmentally sealed
- 1, 2 and 4 pole circuitry
- 2 & 3 position with maintained and momentary action
- Locking actuator for safety
- Molded-in terminal inserts and terminal numbers

SPECIFICATIONS

- Environmentally sealed per MILS-3950
- MS approved and QPL'd per MILS-3950
- Thermoset molding materials meet flame retardant requirements
- Bushing: 15/32" - 32 thread
- Temperature Range: -85°F to +160°F (-65°C to +71°C)
- Life: 20,000 operations at rated load
40,000 operations mechanical life

CURRENT RATINGS

No. of Poles	Catalog Number	Type of Operation	28VDC			115 VAC 60 or 400Hz		
			Lamp Load	Resistive Load	Inductive Load	Lamp Load	Resistive Load	Inductive Load
1	8503	Maintained	5	20	15	3	15	10
		Momentary	4	15	10	2	15	7
2	8504	Maintained	7	20	15	4	15	15
		Momentary	5	18	10	2	11	8
4	8505	Maintained	5	20	12	4	15	15
		Momentary	4	18	10	2	11	8

Minimum Rating: "Intermediate Current" per MIL-S-3950.

LEVER LOCK SELECTION TABLE



8503



8504



8505

CIRCUIT WITH LEVER IN . . .			Lever Lock Bushing Style	ONE POLE		TWO POLE		FOUR POLE	
Up Position	Center Position	Down Position (Keyway)		Flush Screw Terminals		Flush Screw Terminals		Flush Screw Terminals	
				MS Part Number	Catalog Number	MS Part Number	Catalog Number	MS Part Number	Catalog Number
ON →	← OFF →	← ON	A	MS24658-21A	8503K1	MS24659-21A	8504K1	MS24660-21A	8505K1
ON	← OFF →	← ON	B	-21B	K27	-21B	K27	-21B	K27
ON →	← OFF →	← ON	D	-21D	K5	-21D	K5	-21D	K5
ON	← OFF →	ON	E	-21E	K2	-21E	K2	-21E	K2
ON →	← OFF →	ON	F	-21F	K28	-21F	K28	-21F	K28
ON	← OFF →	← ON	G	MS24658-21G	8503K3	MS24659-21G	8504K3	MS24660-21G	8505K3
ON →	← OFF →	← ON	H	-21H	K29	-21H	K29	-21H	K29
ON	← OFF →	← ON	J	-21J	K30	-21J	K30	-21J	K30
ON →	← OFF →	ON	K	-21K	K31	-21K	K31	-21K	K31
ON	← OFF →	ON	L	-21L	K32	-21L	K32	-21L	K32
ON →	← OFF →	ON	M	MS24658-21M	8503K33	MS24659-21M	8504K33	MS24660-21M	8505K33
ON	← OFF →	ON	N	-21N	K4	-21N	K4	-21N	K4
ON	← OFF →	← ON	P	-21P	K34	-21P	K34	-21P	K34
ON →	NONE	← OFF	D	-22D	K10	-22D	K10	-22D	K10
ON →	NONE	← OFF	F	-22F	K35	-22F	K35	-22F	K35
ON	NONE	← OFF	G	MS24658-22G	8503K9	MS24659-22G	8504K9	MS24660-22G	8505K9
ON →	NONE	← ON	D	-23D	K6	-23D	K6	-23D	K6
ON →	NONE	ON	F	-23F	K36	-23F	K36	-23F	K36
ON	NONE	← ON	G	-23G	K7	-23G	K7	-23G	K7
ON	← OFF	NONE	E	-24E	K16	-24E	K16	-24E	K16
ON →	← OFF →	NONE	F	MS24658-24F	8503K37	MS24659-24F	8504K37	MS24660-24F	8505K37
ON →	← OFF →	NONE	K	-24K	K38	-24K	K38	-24K	K38
ON →	← OFF →	NONE	M	-24M	K11	-24M	K11	-24M	K11
ON →	← OFF *	NONE	F	-25F	K22	-25F	K22	-25F	K22
ON →	NONE	ON *	F	-26F	K20	-26F	K20	-26F	K20
* ON	← OFF →	ON *	E	MS24658-27E	8503K12	MS24659-27E	8504K12	MS24660-27E	8505K12
* ON	← OFF →	ON *	L	-27L	K39	-27L	K39	-27L	K39
* ON	← OFF →	ON *	N	-27N	K14	-27N	K14	-27N	K14
NONE	← OFF →	ON *	E	-28E	K15	-28E	K15	-28E	K15
ON →	NONE	← OFF *	F	-29F	K21	-29F	K21	-29F	K21
OFF →	NONE	ON *	F	MS24658-30F	8503K19	MS24659-30F	8504K19	MS24660-30F	8505K19
ON	← OFF →	ON *	E	-31E	K18	-31E	K18	-31E	K18
ON →	← OFF →	ON *	F	-31F	K40	-31F	K40	-31F	K40
ON →	← OFF →	ON *	K	-31K	K41	-31K	K41	-31K	K41
ON	← OFF →	ON *	L	-31L	K13	-31L	K13	-31L	K13

* Momentary contact.

→ Indicates direction against which lever is locked.
See page A71 for circuit diagrams.

① Reference bushing styles on page A26.

MILITARY - ENVIRONMENTALLY SEALED SWITCHES

Series - 8503, 8504, 8505

MIL-S-3950 Lever Lock Switches

LEVER LOCK SELECTION TABLE, CONT'D



8503



8504



8505

CIRCUIT WITH LEVER IN . . .				ONE POLE		TWO POLE		FOUR POLE	
Up Position	Center Position	Down Position (Keyway)	Lever ① Lock Bushing Style	Flush Screw Terminals		Flush Screw Terminals		Flush Screw Terminals	
				MS Part Number	Catalog Number	MS Part Number	Catalog Number	MS Part Number	Catalog Number
ON →	← OFF	ON *	M	MS24658-31M	8503K17	MS24659-31M	8504K17	MS24660-31M	8505K17
ON	← OFF	ON *	N	-31N	K8	-31N	K8	-31N	K8
* ON	← ON	NONE	E	-32E	K23	-32E	K23	-32E	K23
ON	← ON	NONE	E	-33E	K24	-33E	K24	-33E	K24
ON →	ON	NONE	F	-33F	K25	-33F	K25	-33F	K25
ON →	← ON	NONE	K	MS24658-33K	8503K26	MS24659-33K	8504K26	MS24660-33K	8505K26
ON →	← ON	NONE	M	-33M	K42	-33M	K42	-33M	K42
ON →	← ON →	← ON	A	—	—	MS27408-1A	K43	MS27409-1A	K43
ON	← ON →	← ON	B	—	—	-1B	K44	-1B	K44
ON →	ON	← ON	D	—	—	-1D	K45	-1D	K45
ON	← ON →	ON	E	—	—	MS27408-1E	8504K46	MS27409-1E	8505K46
ON →	ON	ON	F	—	—	-1F	K47	-1F	K47
ON	ON	← ON	G	—	—	-1G	K48	-1G	K48
ON →	ON →	ON	H	—	—	-1H	K49	-1H	K49
ON	← ON	← ON	J	—	—	-1J	K50	-1J	K50
ON →	← ON →	ON	K	—	—	MS27408-1K	8504K51	MS27409-1K	8505K51
ON	ON →	ON	L	—	—	-1L	K52	-1L	K52
ON →	← ON	ON	M	—	—	-1M	K53	-1M	K53
ON	← ON	ON	N	—	—	-1N	K54	-1N	K54
ON	ON →	← ON	P	—	—	-1P	K55	-1P	K55
ON	← ON →	ON*	E	—	—	MS27408-2E	8504K56	MS27409-2E	8505K56
ON →	ON	ON*	F	—	—	-2F	K57	-2F	K57
ON →	← ON →	ON*	K	—	—	-2K	K58	-2K	K58
ON	ON →	ON*	L	—	—	-2L	K59	-2L	K59
ON →	← ON	ON*	M	—	—	-2M	K60	-2M	K60
ON	← ON	ON*	N	—	—	MS27408-2N	8504K61	MS27409-2N	8505K61
* ON	← ON →	ON*	E	—	—	-3E	K62	-3E	K62
* ON	ON →	ON*	L	—	—	-3L	K63	-3L	K63
* ON	← ON	ON*	N	—	—	-3N	K64	-3N	K64
ON →	← ON →	← ON	A	—	—	-4A	K65	—	—
ON	← ON →	← ON	B	—	—	MS27408-4B	8504K66	—	—
ON →	ON	← ON	D	—	—	-4D	K67	—	—
ON	← ON →	ON	E	—	—	-4E	K68	—	—
ON →	ON	ON	F	—	—	-4F	K69	—	—
ON	ON	← ON	G	—	—	-4G	K70	—	—
ON →	ON →	ON	H	—	—	MS27408-4H	8504K71	—	—
ON	← ON	← ON	J	—	—	-4J	K72	—	—
ON →	← ON →	ON	K	—	—	-4K	K73	—	—
ON	ON →	ON	L	—	—	-4L	K74	—	—
ON →	← ON	ON	M	—	—	-4M	K75	—	—
ON	← ON	ON	N	—	—	MS27408-4N	8504K76	—	—
ON	ON →	← ON	P	—	—	-4P	K77	—	—
ON	← ON →	ON*	E	—	—	-5E	K78	—	—
ON →	ON	ON*	F	—	—	-5F	K79	—	—
ON →	← ON →	ON*	K	—	—	-5K	K80	—	—
ON	ON →	ON*	L	—	—	MS27408-5L	8504K81	—	—
ON →	← ON	ON*	M	—	—	-5M	K82	—	—
ON	← ON	ON*	N	—	—	-5N	K83	—	—
* ON	← ON →	ON*	E	—	—	-6E	K84	—	—
* ON	ON →	ON*	L	—	—	-6L	K85	—	—
* ON	← ON	ON*	N	—	—	-6N	K86	—	—
ON	← ON-OFF →	← ON	B	—	—	-7B	K87	—	—

* Momentary contact.

→ Indicates direction against which lever is locked.

See page A71 for circuit diagrams.

① Reference bushing styles on page A26.

MOUNTING DIMENSIONS - ONE POLE / 8503

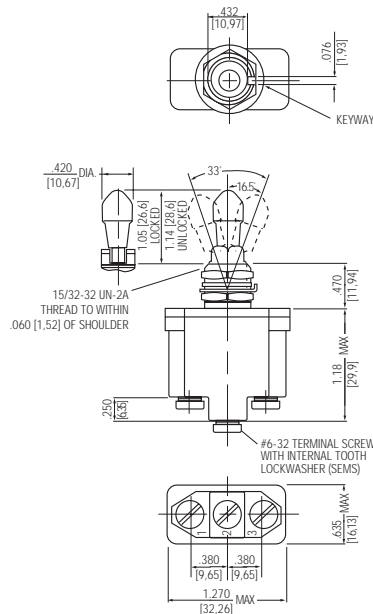

Terminal Identification

MOUNTING DIMENSIONS - TWO POLE / 8504

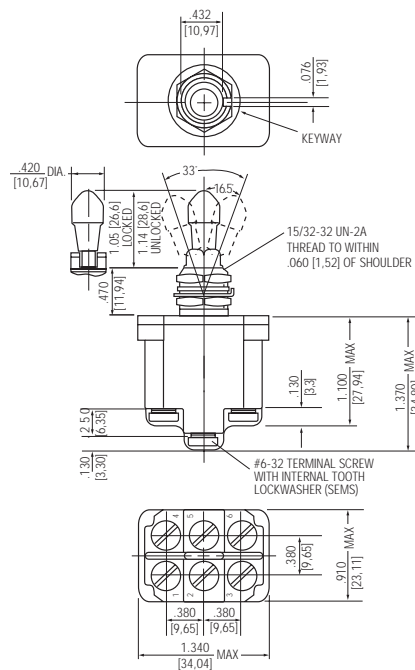

Terminal Identification

STANDARD

0.00 = inches

[0,0] = mm

Mounting dimensions for reference only.

Non-functional terminals not supplied.

MILITARY - ENVIRONMENTALLY SEALED SWITCHES

Series - 8503, 8504, 8505

MIL-S-3950 Lever Lock Switches

MOUNTING DIMENSIONS - FOUR POLE / 8505

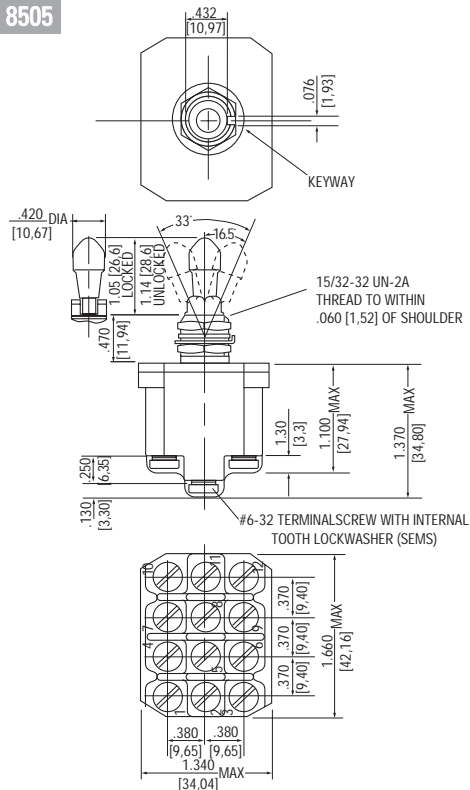

Terminal Identification

Non-functional terminals not supplied.

OPTIONS/ACCESSORIES

- Special mounting hardware
- Mounting hardware furnished assembled
- Terminal screws furnished assembled
- Substitute SEMS screws
- Special circuits
- Panel seal, part number 32-341 (See Accessories and Custom Components section)
- Special shaped caps available
- Custom wiring harnesses

LEVER LOCK - BUSHING STYLES

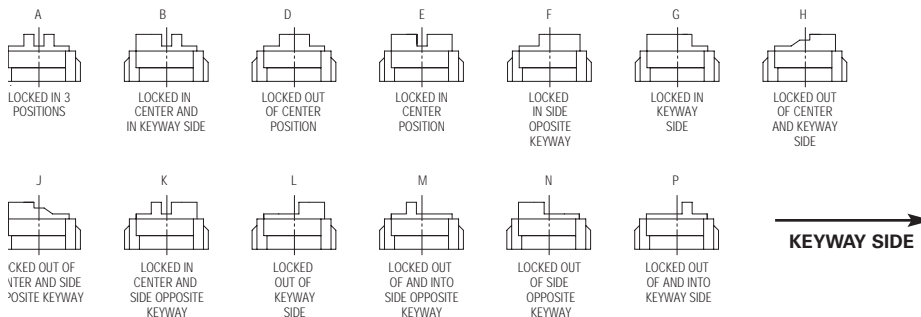

PANEL CUTOUT DIMENSIONS

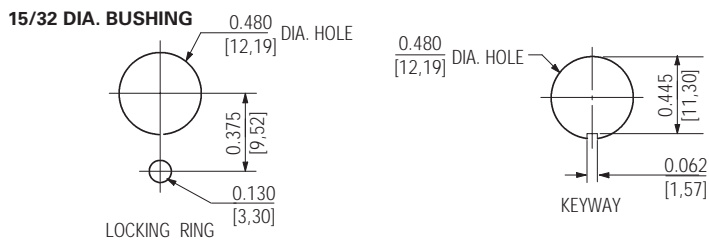

STANDARD
0.00 = inches
[0,0] = mm

Mounting dimensions for reference only.

MILITARY - ENVIRONMENTALLY SEALED SWITCHES

Series - 8570, 8571, 8572

MIL-S-3950 IWTS Switches

FEATURES

- Environmentally sealed
- 1, 2 and 4 pole circuitry
- 2 & 3 position with maintained and momentary action
- Integrated Wire Termination System (IWTS) for ease of wiring
- Terminal numbers molded into silicone base seal

SPECIFICATIONS

- Environmentally sealed per MILS-3950
- MS approved and QPL'd per MILS-3950
- Thermoset molding materials meet flame retardant requirements
- Bushing: 15/32" - 32 thread
- Temperature Range: -85°F to +160°F (-65°C to +71°C)
- Accepts MILC-39029/1-101 pin
- Life: 20,000 operations at rated load
40,000 operations mechanical life

CURRENT RATINGS

CURRENT RATINGS FOR -16

No. of Poles	Catalog Number	Type of Operation	28VDC			115 VAC 60 or 400Hz		
			Lamp Load	Resistive Load	Inductive Load	Lamp Load	Resistive Load	Inductive Load
1	8570	Maintained	5	20	15	3	15	10
		Momentary	4	15	10	2	15	7
2	8571	Maintained	7	20	15	4	15	15
		Momentary	5	18	10	2	11	8
4	8572	Maintained	5	20	12	4	15	15
		Momentary	4	18	10	2	11	8

CURRENT RATINGS FOR -20

No. of Poles	Catalog Number	Type of Operation	28VDC			115 VAC 60 or 400Hz		
			Lamp Load	Resistive Load	Inductive Load	Lamp Load	Resistive Load	Inductive Load
1	8570	Maintained	5	7.5	7.5	3	7.5	7.5
		Momentary	4	7.5	7.5	2	7.5	7
2	8571	Maintained	7.5	7.5	7.5	4	7.5	7.5
		Momentary	5	7.5	7.5	2	7.5	7.5
4	8572	Maintained	5	7.5	7.5	4	7.5	7.5
		Momentary	4	7.5	7.5	2	7.5	7.5

STANDARD LEVER SELECTION TABLE — Terminals Accept Wire Contact Within Dimensional Limits of M39029/1-102 for -16 wire size.
— Terminals Accept Wire Contact Within Dimensional Limits of M39029/1-101 for -20 wire size.



8570



8571



8572

CIRCUIT WITH LEVER IN . . .			ONE POLE		TWO POLE		FOUR POLE	
Up Position	Center Position	Down Position (Keyway)	MS Part Number	Catalog Number	MS Part Number	Catalog Number	MS Part Number	Catalog Number
ON	OFF	ON	MS27722-21	8570K1-16	MS27723-21	8571K1-16	MS27724-21	8572K1-16
ON	NONE	OFF	-22	K9-16	-22	K9-16	-22	K9-16
ON	NONE	ON	-23	K4-16	-23	K4-16	-23	K4-16
ON	OFF	NONE	-24	K6-16	-24	K6-16	-24	K6-16
ON	OFF *	NONE	-25	K8-16	-25	K8-16	-25	K8-16
ON	NONE	ON *	MS27722-26	8570K5-16	MS27723-26	8571K5-16	MS27724-26	8572K5-16
* ON	OFF	ON *	-27	K2-16	-27	K2-16	-27	K2-16
NONE	OFF	ON *	-28	K7-16	-28	K7-16	-28	K7-16
ON	NONE	OFF *	-29	K10-16	-29	K10-16	-29	K10-16
OFF	NONE	ON *	-30	K11-16	-30	K11-16	-30	K11-16
ON	OFF	ON *	MS27722-31	8570K3-16	MS27723-31	8571K3-16	MS27724-31	8572K3-16
* ON	ON	NONE	-32	K12-16	-32	K12-16	-32	K12-16
ON	ON	NONE	-33	K13-16	-33	K13-16	-33	K13-16
ON	ON	ON	—	—	MS27723-1	8571K17-16	MS27724-1	8572K15-16
ON	ON	ON *	—	—	-2	K18-16	-2	K16-16
* ON	ON	ON *	—	—	-3	K19-16	-3	K17-16
ON	OFF	ON	MS27784-21	8570K1-20	MS27785-21	8571K1-20	MS27786-21	8572K1-20
ON	NONE	OFF	-22	K9-20	-22	K9-20	-22	K9-20
ON	NONE	ON	-23	K4-20	-23	K4-20	-23	K4-20
ON	OFF	NONE	-24	K6-20	-24	K6-20	-24	K6-20
ON	OFF *	NONE	-25	K8-20	-25	K8-20	-25	K8-20
ON	NONE	ON *	MS27784-26	8570K5-20	MS27785-26	8571K5-20	MS27786-26	8572K5-20
* ON	OFF	ON *	-27	K2-20	-27	K2-20	-27	K2-20
NONE	OFF	ON *	-28	K7-20	-28	K7-20	-28	K7-20
ON	NONE	OFF *	-29	K10-20	-29	K10-20	-29	K10-20
OFF	NONE	ON *	-30	K11-20	-30	K11-20	-30	K11-20
ON	OFF	ON *	MS27784-31	8570K3-20	MS27785-31	8571K3-20	MS27786-31	8572K3-20
* ON	ON	NONE	-32	K12-20	-32	K12-20	-32	K12-20
ON	ON	NONE	-33	K13-20	-33	K13-20	-33	K13-20
ON	ON	ON	—	—	MS27785-1	8571K17-20	MS27786-1	8572K15-20
ON	ON	ON *	—	—	-2	K18-20	-2	K16-20
* ON	ON	ON *	—	—	-3	K19-20	-3	K17-20

* Momentary contact.
See page A71 for circuit diagrams.

MILITARY - ENVIRONMENTALLY SEALED SWITCHES

Series - 8570, 8571, 8572

MIL-S-3950 IWTS Toggles

MOUNTING DIMENSIONS - ONE POLE / 8570

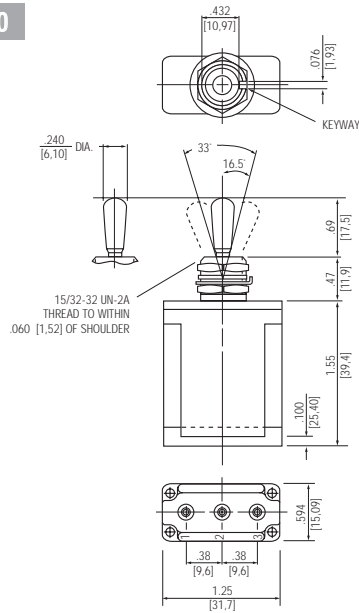

90-6566.6659

Terminal Identification

MOUNTING DIMENSIONS - TWO POLE / 8571

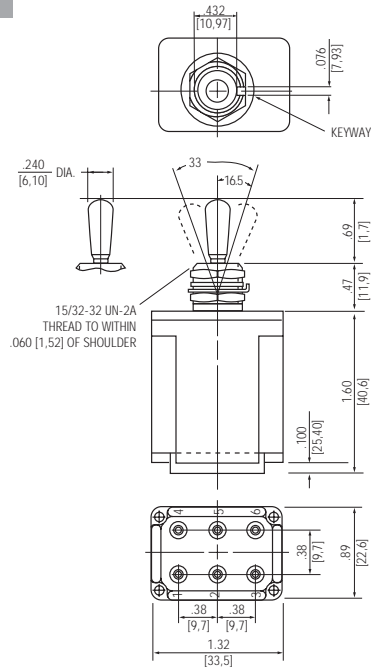

90-6567.6661

Terminal Identification

STANDARD

0.00 = inches

[0,0] = mm

Mounting dimensions for reference only.

Non-functional terminals not supplied.

MOUNTING DIMENSIONS - FOUR POLE/ 8572

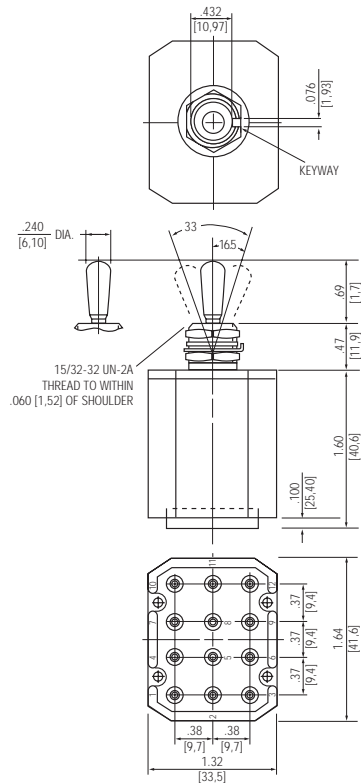

Terminal Identification

Non-functional terminals not supplied.

OPTIONS/ACCESSORIES

- Special mounting hardware
- Mounting hardware furnished assembled
- Special circuits
- Panel seal, part number 32-341 (See Accessories and Custom Components section)
- Special "3 Cateye" luminous lever attachment
- Lever extensions and attachable tips (See Accessories and Custom Components section)
- Custom wiring harnesses

PANEL CUTOUT DIMENSIONS

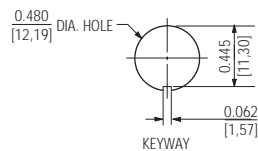
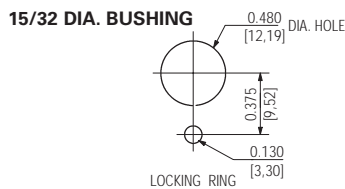

STANDARD

0.00 = inches

[0,0] = mm

Mounting dimensions for reference only.

MILITARY - ENVIRONMENTALLY SEALED SWITCHES

Series - 8573, 8574, 8575

MIL-S-3950 IWTS Lever Locks

FEATURES

- Environmentally sealed
- 1, 2 and 4 pole circuitry
- 2 & 3 position with maintained and momentary action
- Integrated Wire Termination System (IWTS) for ease of wiring
- Terminal numbers molded into silicone base seal

SPECIFICATIONS

- Environmentally sealed per MIL-S-3950
- MS approved and QPL'd per MIL-S-3950
- Thermoset molding materials meet flame retardant requirements
- Bushing: 15/32" - 32 thread
- Temperature Range: -85°F to +160°F (65°C to +71°C)
- Accepts MIL-C-39029/1-101 pin
- Life: 20,000 operations at rated load
40,000 operations mechanical life

CURRENT RATINGS

CURRENT RATINGS FOR -16

No. of Poles	Catalog Number	Type of Operation	28VDC			115 VAC 60 or 400Hz		
			Lamp Load	Resistive Load	Inductive Load	Lamp Load	Resistive Load	Inductive Load
1	8573	Maintained	5	20	15	3	15	10
		Momentary	4	15	10	2	15	7
2	8574	Maintained	7	20	15	4	15	15
		Momentary	5	18	10	2	11	8
4	8575	Maintained	5	20	12	4	15	15
		Momentary	4	18	10	2	11	8

Minimum Rating: "Intermediate Current" per MIL-S-3950.

CURRENT RATINGS FOR -20

No. of Poles	Catalog Number	Type of Operation	28VDC			115 VAC 60 or 400Hz		
			Lamp Load	Resistive Load	Inductive Load	Lamp Load	Resistive Load	Inductive Load
1	8573	Maintained	5	7.5	7.5	3	7.5	7.5
		Momentary	4	7.5	7.5	2	7.5	7
2	8574	Maintained	7	7.5	7.5	4	7.5	7.5
		Momentary	5	7.5	7.5	2	7.5	7.5
4	8575	Maintained	5	7.5	7.5	4	7.5	7.5
		Momentary	4	7.5	7.5	2	7.5	7.5

LEVER LOCK SELECTION TABLE — Terminals Accept Wire Contact Within Dimensional Limits of M39029/1-102 for -16 wire size.
— Terminals Accept Wire Contact Within Dimensional Limits of M39029/1-101 for -20 wire size.



8573



8574



8575

			ONE POLE		TWO POLE		FOUR POLE		
Up Position	Center Position	Down Position (Keyway)	Lever Lock Bushing Style	Flush Screw Terminals	Flush Screw Terminals	Flush Screw Terminals	Flush Screw Terminals	Flush Screw Terminals	
				MS Part Number	Catalog Number	MS Part Number	Catalog Number	MS Part Number	Catalog Number
ON →	OFF →	← ON	A	MS27781-21A	8573K1-16	MS27782-21A	8574K1-16	MS27783-21A	8575K1-16
ON	OFF →	← ON	B	-21B	K27-16	-21B	K27-16	-21B	K27-16
ON →	OFF	← ON	D	-21D	K5-16	-21D	K5-16	-21D	K5-16
ON	OFF →	ON	E	-21E	K2-16	-21E	K2-16	-21E	K2-16
ON →	OFF	ON	F	-21F	K28-16	-21F	K28-16	-21F	K28-16
ON	OFF	← ON	G	MS27781-21G	8573K3-16	MS27782-21G	8574K3-16	MS27783-21G	8575K3-16
ON →	OFF →	ON	H	-21H	K29-16	-21H	K29-16	-21H	K29-16
ON	OFF	← ON	J	-21J	K30-16	-21J	K30-16	-21J	K30-16
ON →	OFF →	ON	K	-21K	K31-16	-21K	K31-16	-21K	K31-16
ON	OFF →	ON	L	-21L	K32-16	-21L	K32-16	-21L	K32-16
ON →	OFF	ON	M	MS27781-21M	8573K33-16	MS27782-21M	8574K33-16	MS27783-21M	8575K33-16
ON	OFF	ON	N	-21N	K4-16	-21N	K4-16	-21N	K4-16
ON	OFF →	← ON	P	-21P	K34-16	-21P	K34-16	-21P	K34-16
ON →	NONE	← OFF	D	-22D	K10-16	-22D	K10-16	-22D	K10-16
ON →	NONE	OFF	F	-22F	K35-16	-22F	K35-16	-22F	K35-16
ON	NONE	← OFF	G	MS27781-22G	8573K9-16	MS27782-22G	8574K9-16	MS27783-22G	8575K9-16
ON →	NONE	← ON	D	-23D	K6-16	-23D	K6-16	-23D	K6-16
ON →	NONE	ON	F	-23F	K36-16	- 23F	K36-16	-23F	K36-16
ON	NONE	← ON	G	-23G	K7-16	-23G	K7-16	-23G	K7-16
ON	← OFF	NONE	E	-24E	K16-16	-24E	K16-16	-24E	K16-16
ON →	OFF	NONE	F	MS27781-24F	8573K37-16	MS27782-24F	8574K37-16	MS27783-24F	8575K37-16
ON →	← OFF	NONE	K	-24K	K38-16	-24K	K38-16	-24K	K38-16
ON →	← OFF	NONE	M	-24M	K11-16	-24M	K11-16	-24M	K11-16
ON →	OFF*	NONE	F	-25F	K22-16	-25F	K22-16	-25F	K22-16
ON →	NONE	ON*	F	-26F	K20-16	-26F	K20-16	-26F	K20-16
* ON	← OFF →	ON*	E	MS27781-27E	8573K12-16	MS27782-27E	8574K12-16	MS27783-27E	8575K12-16
* ON	OFF →	ON*	L	-27L	K39-16	-27L	K39-16	-27L	K39-16
* ON	← OFF	ON*	N	-27N	K14-16	-27N	K14-16	-27N	K14-16
NONE	OFF →	ON*	E	-28E	K15-16	-28E	K15-16	-28E	K15-16
ON →	NONE	OFF*	F	-29F	K21-16	-29F	K21-16	-29F	K21-16
OFF →	NONE	ON*	F	MS27781-30F	8573K19-16	MS27782-30F	8574K19-16	MS27783-30F	8575K19-16
ON	← OFF →	ON*	E	-31E	K18-16	-31E	K18-16	-31E	K18-16
ON →	OFF	ON*	F	-31F	K40-16	-31F	K40-16	-31F	K40-16
ON →	← OFF →	ON*	K	-31K	K41-16	-31K	K41-16	-31K	K41-16
ON	OFF →	ON*	L	-31L	K13-16	-31L	K13-16	-31L	K13-16

* Momentary contact.

→ Indicates direction against which lever is locked.
See page A71 for circuit diagrams.

Ⓛ Reference bushing styles on page A34.

LEVER LOCK SELECTION TABLE, CONT'D



8573



8574



8575

CIRCUIT WITH LEVER IN . . .				ONE POLE		TWO POLE		FOUR POLE	
Up Position	Center Position	Down Position (Keyway)	Lever ① Lock Bushing Style	Flush Screw Terminals		Flush Screw Terminals		Flush Screw Terminals	
				MS Part Number	Catalog Number	MS Part Number	Catalog Number	MS Part Number	Catalog Number
ON→	← OFF	ON*	M	MS27781-31M	8573K17-16	MS27782-31M	8574K17-16	MS27783-31M	8575K17-16
ON	← OFF	ON*	N	-31N	K8-16	-31N	K8-16	-31N	K8-16
*ON	← ON	NONE	E	-32E	K23-16	-32E	K23-16	-32E	K23-16
ON	← ON	NONE	E	-33E	K24-16	-33E	K24-16	-33E	K24-16
ON→	ON	NONE	F	-33F	K25-16	-33F	K25-16	-33F	K25-16
ON→	← ON	NONE	K	MS27781-33K	8573K26-16	MS27782-33K	8574K26-16	MS27783-33K	8575K26-16
ON→	← ON	NONE	M	-33M	K42-16	-33M	K42-16	-33M	K42-16
ON→	← ON→	ON	A	—	—	-1A	K65-16	-1A	K43-16
ON	← ON→	ON	B	—	—	-1B	K66-16	-1B	K44-16
ON→	ON	ON	D	—	—	-1D	K67-16	-1D	K45-16
ON	← ON→	ON	E	—	—	MS27782-1E	8574K68-16	MS27783-1E	8575K46-16
ON→	ON	ON	F	—	—	-1F	K69-16	-1F	K47-16
ON	ON	ON	G	—	—	-1G	K70-16	-1G	K48-16
ON→	ON→	ON	H	—	—	-1H	K71-16	-1H	K49-16
ON	← ON←	ON	J	—	—	-1J	K72-16	-1J	K50-16
ON→	← ON→	ON	K	—	—	MS27782-1K	8574K73-16	MS27783-1K	8575K51-16
ON	ON→	ON	L	—	—	-1L	K74-16	-1L	K52-16
ON→	← ON	ON	M	—	—	-1M	K75-16	-1M	K53-16
ON	← ON	ON	N	—	—	-1N	K76-16	-1N	K54-16
ON	ON→	ON	P	—	—	-1P	K77-16	-1P	K55-16
ON	← ON→	ON*	E	—	—	MS27782-2E	8574K78-16	MS27783-2E	8575K56-16
ON→	ON	ON*	F	—	—	-2F	K79-16	-2F	K57-16
ON→	← ON→	ON*	K	—	—	-2K	K80-16	-2K	K58-16
ON	ON→	ON*	L	—	—	-2L	K81-16	-2L	K59-16
ON→	← ON	ON*	M	—	—	-2M	K82-16	-2M	K60-16
ON	← ON	ON*	N	—	—	MS27782-2N	8574K83-16	MS27783-2N	8575K61-16
ON	← ON→	ON	E	—	—	-3E	K84-16	-3E	K62-16
ON	← ON→	ON	L	—	—	-3L	K85-16	-3L	K63-16
ON	← ON	ON	N	—	—	-3N	K86-16	-3N	K64-16

* Momentary contact.

→ Indicates direction against which lever is locked.



See page A71 for circuit diagrams.

① Reference bushing styles on page A34.

MILITARY - ENVIRONMENTALLY SEALED SWITCHES

Series - 8573, 8574, 8575

MIL-S-3950 IWTS Lever Locks

CIRCUIT WITH LEVER IN . . .			ONE POLE		TWO POLE		FOUR POLE		
Up Position	Center Position	Down Position (Keyway)	Lever Lock Bushing Style	Flush Screw Terminals		Flush Screw Terminals		Flush Screw Terminals	
				MS Part Number	Catalog Number	MS Part Number	Catalog Number	MS Part Number	Catalog Number
ON →	← OFF →	← ON	A	MS27787-21A	8573K1-20	MS27788-21A	8574K1-20	MS27789-21A	8575K1-20
ON	← OFF →	← ON	B	-21B	K27-20	-21B	K27-20	-21B	K27-20
ON →	← OFF →	← ON	D	-21D	K5-20	-21D	K5-20	-21D	K5-20
ON	← OFF →	← ON	E	-21E	K2-20	-21E	K2-20	-21E	K2-20
ON →	← OFF →	← ON	F	-21F	K28-20	-21F	K28-20	-21F	K28-20
ON	OFF	← ON	G	MS27787-21G	8573K3-20	MS27788-21G	8574K3-20	MS27789-21G	8575K3-20
ON →	← OFF →	← ON	H	-21H	K29-20	-21H	K29-20	-21H	K29-20
ON	← OFF →	← ON	J	-21J	K30-20	-21J	K30-20	-21J	K30-20
ON →	← OFF →	← ON	K	-21K	K31-20	-21K	K31-20	-21K	K31-20
ON	← OFF →	← ON	L	-21L	K32-20	-21L	K32-20	-21L	K32-20
ON →	← OFF →	← ON	M	MS27787-21M	8573K33-20	MS27788-21M	8574K33-20	MS27789-21M	8575K33-20
ON	← OFF →	← ON	N	-21N	K4-20	-21N	K4-20	-21N	K4-20
ON	OFF →	← ON	P	-21P	K34-20	-21P	K34-20	-21P	K34-20
ON →	NONE	← OFF	D	-22D	K10-20	-22D	K10-20	-22D	K10-20
ON →	NONE	← OFF	F	-22F	K35-20	-22F	K35-20	-22F	K35-20
ON	NONE	← OFF	G	MS27787-22G	8573K9-20	MS27788-22G	8574K9-20	MS27789-22G	8575K9-20
ON →	NONE	← ON	D	-23D	K6-20	-23D	K6-20	-23D	K6-20
ON →	NONE	← ON	F	-23F	K36-20	-23F	K36-20	-23F	K36-20
ON	NONE	← ON	G	-23G	K7-20	-23G	K7-20	-23G	K7-20
ON	← OFF	NONE	E	-24E	K16-20	-24E	K16-20	-24E	K16-20
ON →	← OFF	NONE	F	MS27787-24F	8573K37-20	MS27788-24F	8574K37-20	MS27789-24F	8575K37-20
ON →	← OFF	NONE	K	-24K	K38-20	-24K	K38-20	-24K	K38-20
ON →	← OFF	NONE	M	-24M	K11-20	-24M	K11-20	-24M	K11-20
ON →	← OFF	NONE	F	-25F	K22-20	-25F	K22-20	-25F	K22-20
ON →	← OFF	ON *	F	-26F	K20-20	-26F	K20-20	-26F	K20-20
*ON	← OFF →	ON *	E	MS27787-27E	8573K12-20	MS27788-27E	8574K12-20	MS27789-27E	8575K12-20
*ON	← OFF →	ON *	L	-27L	K39-20	-27L	K39-20	-27L	K39-20
*ON	← OFF →	ON *	N	-27N	K14-20	-27N	K14-20	-27N	K14-20
NONE	← OFF →	ON *	E	-28E	K15-20	-28E	K15-20	-28E	K15-20
ON →	← OFF →	OFF *	F	-29F	K21-20	-29F	K21-20	-29F	K21-20
OFF →	← NONE	ON *	F	MS27787-30F	8573K19-20	MS27788-30F	8574K19-20	MS27789-30F	8575K19-20
ON	← OFF →	ON *	E	-31E	K18-20	-31E	K18-20	-31E	K18-20
ON →	← OFF →	ON *	F	-31F	K40-20	-31F	K40-20	-31F	K40-20
ON →	← OFF →	ON *	K	-31K	K41-20	-31K	K41-20	-31K	K41-20
ON	← OFF →	ON *	L	-31L	K13-20	-31L	K13-20	-31L	K13-20
ON →	← OFF	ON *	M	MS27787-31M	8573K17-20	MS27788-31M	8574K17-20	MS27789-31M	8575K17-20
ON	← OFF	ON *	N	-31N	K8-20	-31N	K8-20	-31N	K8-20
*ON	← ON	NONE	E	-32E	K23-20	-32E	K23-20	-32E	K23-20
ON	← ON	NONE	E	-33E	K24-20	-33E	K24-20	-33E	K24-20
ON →	← ON	NONE	F	-33F	K25-20	-33F	K25-20	-33F	K25-20
ON →	← ON	NONE	K	MS27787-33K	8573K26-20	MS27788-33K	8574K26-20	MS27789-33K	8575K26-20
ON →	← ON	NONE	M	-33M	K42-20	-33M	K42-20	-33M	K42-20
ON →	← ON →	← ON	A	—	—	-1A	K65-20	-1A	K43-20
ON	← ON →	← ON	B	—	—	-1B	K66-20	-1B	K44-20
ON →	← ON	← ON	D	—	—	-1D	K67-20	-1D	K45-20
ON	← ON →	ON	E	—	—	MS27788-1E	8574K68-20	MS27789-1E	8575K46-20
ON →	← ON	ON	F	—	—	-1F	K69-20	-1F	K47-20
ON	ON	← ON	G	—	—	-1G	K70-20	-1G	K48-20
ON →	← ON →	ON	H	—	—	-1H	K71-20	-1H	K49-20
ON	← ON	← ON	J	—	—	-1J	K72-20	-1J	K50-20
ON →	← ON →	ON	K	—	—	MS27788-1K	8574K73-20	MS27789-1K	8575K51-20
ON	ON	ON	L	—	—	-1L	K74-20	-1L	K52-20
ON →	← ON	ON	M	—	—	-1M	K75-20	-1M	K53-20
ON	← ON	ON	N	—	—	-1N	K76-20	-1N	K54-20
ON	ON →	← ON	P	—	—	-1P	K77-20	-1P	K55-20
ON	← ON →	ON *	E	—	—	MS27788-2E	8574K78-20	MS27789-2E	8575K56-20
ON →	← ON	ON *	F	—	—	-2F	K79-20	-2F	K57-20
ON →	← ON →	ON *	K	—	—	-2K	K80-20	-2K	K58-20
ON	ON →	ON *	L	—	—	-2L	K81-20	-2L	K59-20
ON →	← ON	ON *	M	—	—	-2M	K82-20	-2M	K60-20
ON	← ON	ON *	N	—	—	MS27788-2N	8574K83-20	MS27789-2N	8575K61-20
*ON	← ON →	ON *	E	—	—	-3E	K84-20	-3E	K62-20
*ON	ON →	ON *	L	—	—	-3L	K85-20	-3L	K63-20
*ON	← ON	ON *	N	—	—	-3N	K86-20	-3N	K64-20

* Momentary contact.

→ Indicates direction against which lever is locked.

See page A71 for circuit diagrams.

Ⓛ Reference bushing styles on page A34.

MOUNTING DIMENSIONS - ONE POLE / 8573

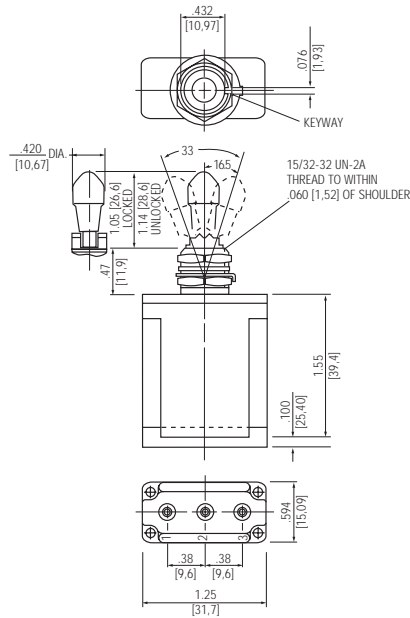

Terminal Identification

MOUNTING DIMENSIONS - TWO POLE / 8574

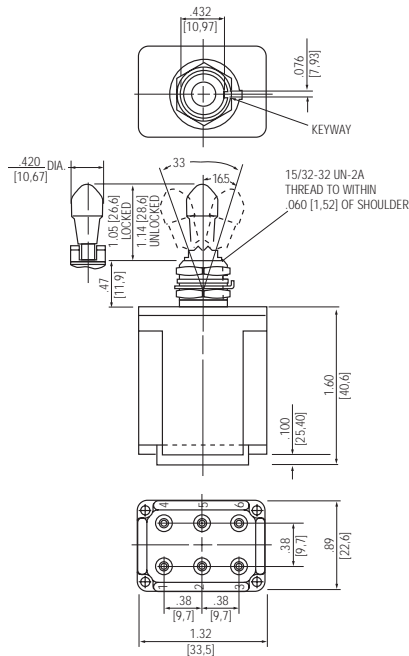

Terminal Identification

STANDARD
 0.00 = inches
 [0,0] = mm

Mounting dimensions for reference only.

Non-functional terminals not supplied.

MILITARY - ENVIRONMENTALLY SEALED SWITCHES

Series - 8573, 8574, 8575

MIL-S-3950 IWTS Lever Locks

MOUNTING DIMENSIONS - FOUR POLE / 8575

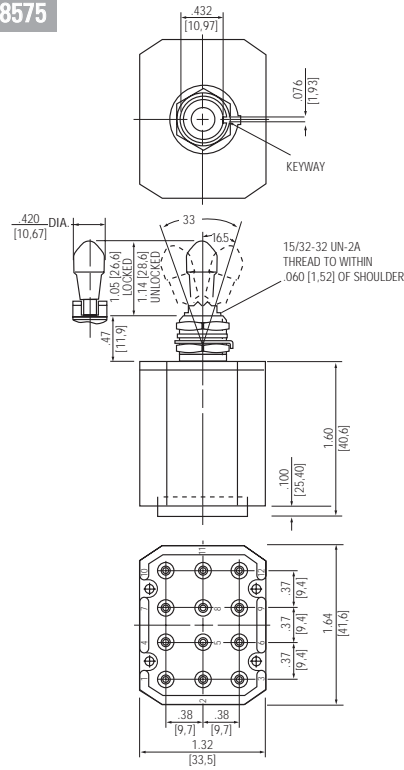

90-6696 90-6680.AI

Terminal Identification

Non-functional terminals not supplied.

OPTIONS/ACCESSORIES

LEVER LOCK - BUSHING STYLES

- Special mounting hardware
- Mounting hardware furnished assembled
- Special circuits
- Panel seal, part number 32-341 (See Accessories and Custom Components section)
- Special shaped caps available
- Custom wiring harnesses

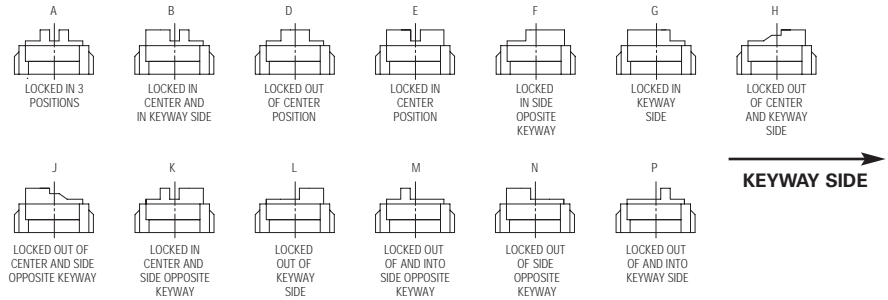

PANEL CUTOUT DIMENSIONS

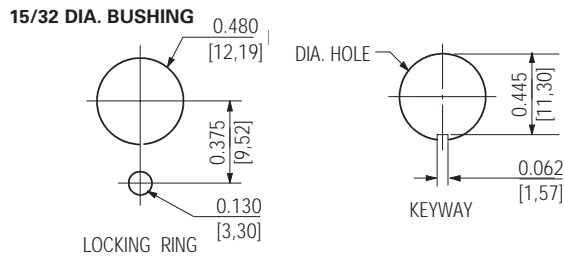

STANDARD

0.00 = inches

[0,0] = mm

Mounting dimensions for reference only.

FEATURES

- Two and three position
- Isolated circuitry multi-circuit, compact 2, 4, 6 or 8 poles
- Maintained and momentary action
- Lever locking configurations
- Stainless steel construction
- Double turret terminals

SPECIFICATIONS

- Ambient operating temperature: -40°F to +165°F (-40°C to +74°C)
- Operating force 1 to 6 pounds (.22 to 1.35N)
- Electrical life: 25,000 operations minimum
- Mechanical life: 100,000 operations minimum

CURRENT RATINGS

No. of Poles	Part Number	Basic Switches	28VDC				115VAC			
			Inrush [Ⓛ] Load	Resistive Load	Inductive Load	Lamp Load	Inrush Load	Resistive Load	Inductive Load	Lamp Load
2	A3-212 to A3-213	STD	25	7	4	2.5	20	7	7	2
4	A3-200 to A3-201	STD	25	7	4	2.5	20	7	7	2
6	A3-202 to A3-203	STD	25	7	4	2.5	20	7	7	2
8	A3-204 to A3-205	STD	25	7	4	2.5	20	7	7	2
2	A3-214 to A3-215	Sealed	24	5	3	2.4	15	5	5	1.5
4	A3-206 to A3-207	Sealed	24	5	3	2.4	15	5	5	1.5
6	A3-208 to A3-209	Sealed	24	5	3	2.4	15	5	5	1.5
8	A3-210 to A3-211	Sealed	24	5	3	2.4	15	5	5	1.5

Ⓛ 0.05 sec. duration.

SELECTION TABLE

TOGGLE POSITION & ACTION

WITH STANDARD BASIC SWITCHES

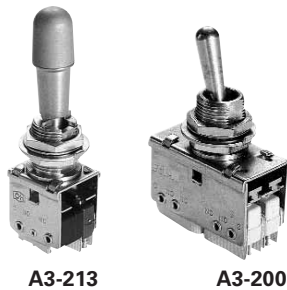

A3-213

A3-200

	Position #1 (D-Flat)	Position #2 (Center)	Position #3 (Opposite)	2 Poles	4 Poles	6 Poles	8 Poles	Lever Lock Options
STANDARD (NON-LOCKING) TOGGLES								
2 Position	On *On	None None	On* On	A3-212-07 -06	A3-200-07 -06	A3-202-07 -06	A3-204-07 -06	
	On	None	On	-05	-05	-05	-05	
3 Position	*On On *On On	Off Off Off Off	On* On* On On	A3-212-04 -03 -02 -01	A3-200-04 -03 -02 -01	A3-202-04 -03 -02 -01	A3-204-04 -03 -02 -01	
LEVER-LOCK TOGGLES (Complete by adding code letter from below after "slash")								
2 Position	On *On On	None None None	On* On On	A3-213-07/ -06/ -05/	A3-201-07/ -06/ -05/	A3-203-07/ -06/ -05/	A3-205-07/ -06/ -05/	G F D, F, G
3 Position	*On On *On On	Off Off Off Off	On* On* On On	A3-213-04/ -03/ -02/ -01/	A3-201-04/ -03/ -02/ -01/	A3-203-04/ -03/ -02/ L, M, N -01/	A3-205-04/ -03/ -02/ -01/	E, L, N B, E, G, J, L, N, P E, F, H, K, A, B, D, E, F, G, H, J, K, L, M, N, P

TOGGLE POSITION & ACTION

WITH SEALED BASIC SWITCHES

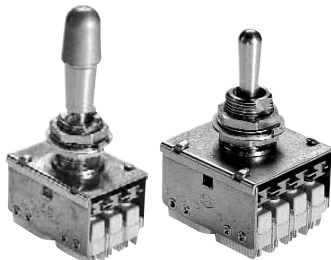

A3-209

A3-210

	Position #1 (D-Flat)	Position #2 (Center)	Position #3 (Opposite)	2 Poles	4 Poles	6 Poles	8 Poles	Lever Lock Options
Standard (Non-Locking Toggles)								
2 Position	On *On On	None None None	On* On On	A3-214-07 -06 -05	A3-206-07 -06 -05	A3-208-07 -06 -05	A3-210-07 -06 -05	
3 Position	*On On *On On	Off Off Off Off	On* On* On On	A3-214-04 -03 -02 -01	A3-206-04 -03 -02 -01	A3-208-04 -03 -02 -01	A3-210-04 -03 -02 -01	
LEVER-LOCK TOGGLES (Complete by adding code letter from below after "slash")								
2 Position	On *On On	None None None	On* On On	A3-215-07/ -06/ -05/	A3-207-07/ -06/ -05/	A3-209-07/ -06/ -05/	A3-211-07/ -06/ -05/	G F D, F, G
3 Position	*On On *On On	Off Off Off Off	On* On* On On	A3-215-04/ -03/ -02/ -01/	A3-207-04/ -03/ -02/ -01/	A3-209-04/ -03/ -02/ -01/	A3-211-04/ -03/ -02/ -01/	E, L, N B, E, G, J, L, N, P E, F, H, K, L, M, N A, B, D, E, F, G, H, J, K, L, M, N, P

* Momentary contact. See page A71 for circuit diagrams.

LEVER LOCKING CONFIGURATION SUFFIXES

- A** - Locked in three positions
- B** - Locked in center and extreme position ("D" flat side)
- D** - Locked out of center position
- E** - Locked in center position
- F** - Locked in extreme position

- (Opposite "D" flat)
- G** - Locked in extreme position ("D" flat side)
- H** - Locked out of center and extreme position ("D" flat side)
- J** - Locked out of center and extreme position Opposite "D" flat

- K** - Locked in center and extreme position (Opposite "D" flat)
- L** - Locked out of extreme position ("D" flat side)
- M** - Locked out of and into extreme position (Opposite "D" flat)
- N** - Locked out of extreme position (Opposite "D" flat)

- P** - Locked out of and into extreme position ("D" flat side)

MULTI-CIRCUIT SWITCHES

Multi-Circuit Toggle Switches

APPROXIMATE DIMENSIONS

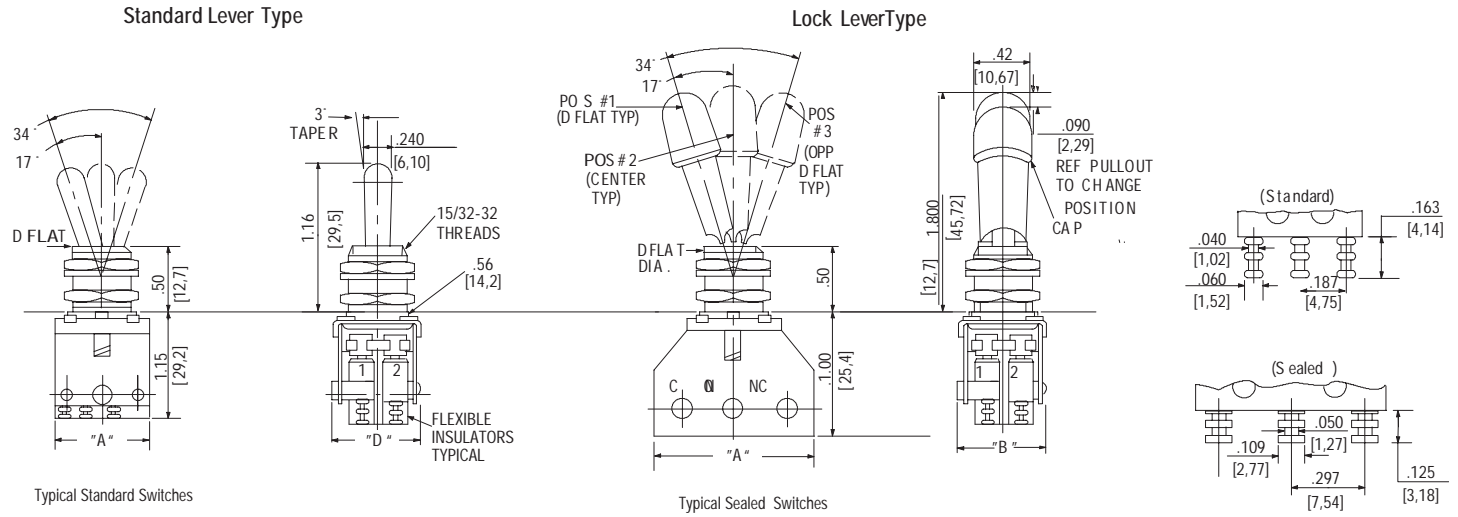

STANDARD

Max. Dimension	2 Pole	4 Pole	6 Pole	8 Pole
"A"	0.72 in. (18.3 mm)	1.30 in. (33.0 mm)	1.30 in. (33.0 mm)	1.30 in. (33.0 mm)
"B"	0.67 in. (17.0 mm)	0.67 in. (17.0 mm)	0.93 in. (23.6 mm)	1.17 in. (29.7 mm)

SEALED

Max. Dimension	2 Pole	4 Pole	6 Pole	8 Pole
"A"	1.22 in. (31.0 mm)	1.65 in. (41.9 mm)	1.65 in. (41.9 mm)	1.65 in. (41.9 mm)
"B"	0.67 in. (17.0 mm)	0.67 in. (17.0 mm)	0.93 in. (23.6 mm)	1.17 in. (29.7 mm)

CROSS REFERENCE

MIL-S-8805	Eaton Part Number
M8805/93-001	A3-212-1
M8805/93-002	A3-212-2
M8805/93-003	A3-212-3
M8805/93-004	A3-212-4
M8805/93-005	A3-212-5
M8805/93-006	A3-212-6
M8805/93-007	A3-212-7
M8805/93-008	A3-200-1
M8805/93-009	A3-200-2
M8805/93-010	A3-200-3
M8805/93-011	A3-200-4
M8805/93-012	A3-200-5
M8805/93-013	A3-200-6
M8805/93-014	A3-200-7
M8805/93-015	A3-202-1
M8805/93-016	A3-202-2
M8805/93-017	A3-202-3
M8805/93-018	A3-202-4
M8805/93-019	A3-202-5
M8805/93-020	A3-202-6
M8805/93-021	A3-202-7
M8805/93-022	A3-204-1
M8805/93-023	A3-204-2
M8805/93-024	A3-204-3
M8805/93-025	A3-204-4
M8805/93-026	A3-204-5
M8805/93-027	A3-204-6
M8805/93-028	A3-204-7

BACK CONFIGURATIONS

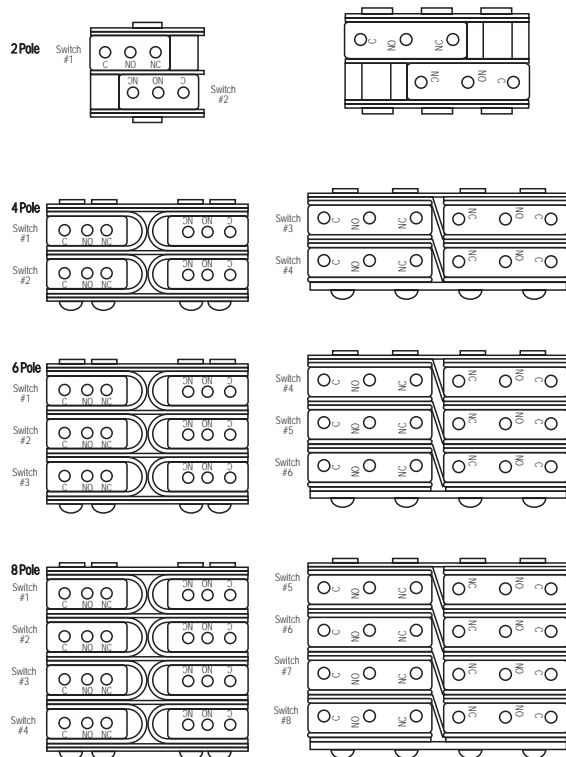

SCHEMATIC DIAGRAMS

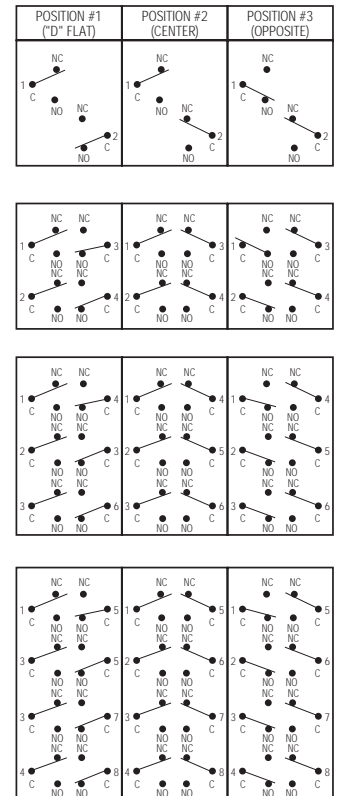

ORDERING EXAMPLES

- Standard - A3-206-03 equals a 3-position (ON-OFF-MOM ON) 4-pole switch with sealed basics.
- Lever Lock - A3-213-04/E equals a 3-position (MOM ON-OFF-MOM ON) 2-pole switch with std. basics and E-lock.
- Available Locking Configurations (See table above. Add code letter after partial type number.)

LEVER LOCKING CONFIGURATION SUFFIXES - BUSHING STYLES

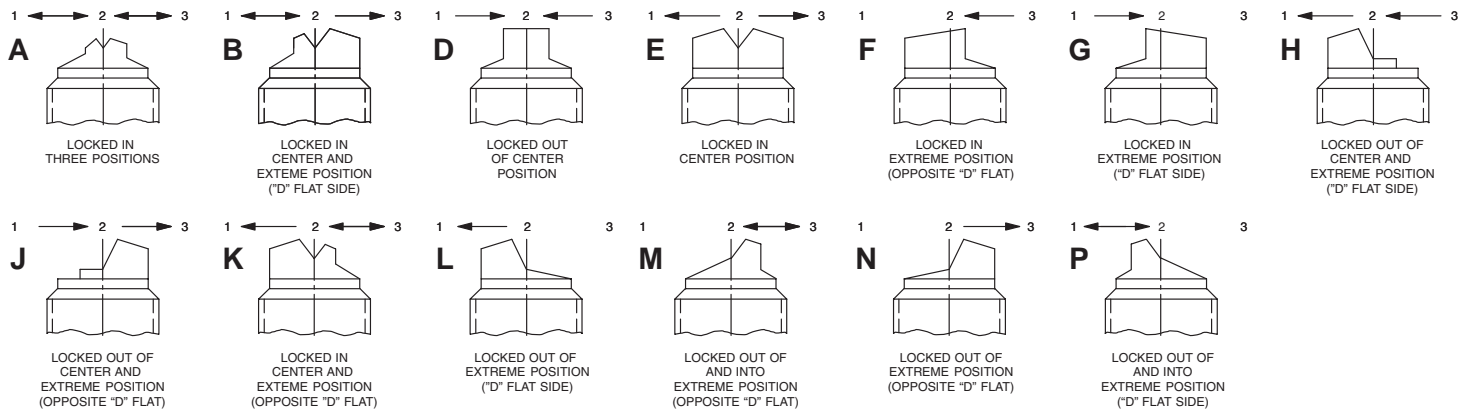

Notes: 1. Arrows (<->) indicated lever must be unlocked to move against the arrow direction.
 2. "D" flat is on the left side as viewed.

OPTIONS/ACCESSORIES

- Low level circuitry
- Pin type termination
- Quick Connect terminals
- Lever seal
- Various color caps available

PANEL CUTOUT DIMENSIONS

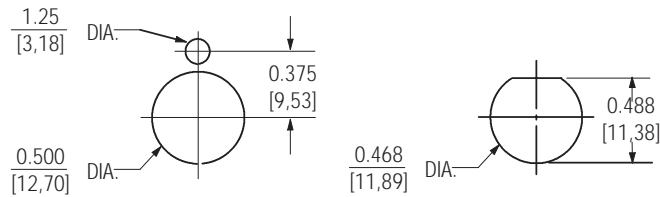

Recommended Panel Mounting Dimensions

ENVIRONMENTALLY SEALED POSITIVE ACTION SWITCHES

Series-8836-8838 & 8843-8845

MIL-S-8834 Environmentally Sealed Positive Action Switches

FEATURES

- Environmentally sealed
- High electrical/ mechanical reliability
- Non-teasible mechanism
- Wiping action contacts
- Positive make and break action
- Molded-in terminal numbers
- One hole mounting for easy installation
- Terminal variations
- Toggle and lever lock Actuator
- Dry circuit (logic level loads) to power switching levels
- Solderable screw terminals
- 1, 2 and 4 pole circuitry

SPECIFICATIONS

- Environmentally sealed per MIL-S-8834
- MS approved and QPL'd per MIL-S-8834
- Two terminal variations
 - Screw 6-32 UNC-2B threads
 - Solder Lug .125 [3,17] dia. hole
- Temperature range: -67°F to +160°F (-55°C to +71°C)
- Life: 20,000 cycles at rated load
40,000 cycles mechanical life
- Positive action mechanism for high reliability and low contact bounce

CURRENT RATINGS







No. of Poles	Catalog Number	Type of Operation	28VDC (Amperes per pole)			115 VAC 400Hz			115VAC 60Hz		
			Lamp Load	Resistive Load	Inductive Load	Lamp Load	Resistive Load	Inductive Load	Lamp Load	Resistive Load	Inductive Load
1	8836 & 8843	Maintained & Momentary	7	25	15	7	25	15	7	20	15
2	8837 & 8844	Maintained & Momentary	7	25	15	7	25	15	7	20	15
4	8838 & 8845	Maintained & Momentary	7	25	15	7	25	15	7	20	15

Minimum Rating: 10 milliamperes at 5 millivolts.

LEVER LOCK SELECTION TABLE

CIRCUIT WITH LEVER IN . . .

CATALOG NUMBER

	Up Position	Center Position	Down Position (Keyway)	Screw Terminal		Solder Lug	
				MS Part Number	Catalog Number	MS Part Number	Catalog Number
ONE POLE							
8836 	ON	OFF	ON	MS25306-212	8836K1	MS14001-212	8836K91
	ON	NONE	OFF	-222	K9	-222	K99
	ON	NONE	ON	-232	K4	-232	K94
	ON	OFF	NONE	-242	K6	-242	K96
	ON	NONE	ON*	MS25306-262	8836K5	MS14001-262	8836K95
	* ON	OFF	ON*	-272	K2	-272	K92
	NONE	OFF	ON*	-282	K7	-282	K97
	ON	NONE	OFF*	-292	K10	-292	K910
	OFF	NONE	ON*	MS25306-302	8836K11	MS14001-302	8836K911
	ON	OFF	ON*	-312	K13	-312	K93
TWO POLE							
8837 	ON	OFF	ON	MS25307-212	8837K1	MS14002-212	8837K91
	ON	NONE	OFF	-222	K9	-222	K99
	ON	NONE	ON	-232	K4	-232	K94
	ON	OFF	NONE	-242	K6	-242	K96
	ON	NONE	ON*	MS25307-262	8837K5	MS14002-262	8837K95
	* ON	OFF	ON*	-272	K2	-272	K92
	NONE	OFF	ON*	-282	K7	-282	K97
	ON	NONE	OFF*	-292	K10	-292	K910
	OFF	NONE	ON*	MS25307-302	8837K11	MS14002-302	8837K911
	ON	OFF	ON*	-312	K3	-312	K93
FOUR POLE							
8838 	ON	OFF	ON	MS25308-212	8838K1	MS14003-212	8838K91
	ON	NONE	OFF	-222	K9	-222	K99
	ON	NONE	ON	-232	K4	-232	K94
	ON	OFF	NONE	-242	K6	-242	K96
	ON	NONE	ON*	MS25308-262	8838K5	MS14003-262	8838K95
	* ON	OFF	ON*	-272	K2	-272	K92
	NONE	OFF	ON*	-282	K7	-282	K97
	ON	NONE	OFF*	-292	K10	-292	K910
	OFF	NONE	ON*	MS25308-302	8838K11	MS14003-302	8838K911
	ON	OFF	ON*	-312	K3	-312	K93

* **Momentary contact.**

See page A75 for special circuit diagrams.
Note: Screw terminal version shown.

ENVIRONMENTALLY SEALED POSITIVE ACTION SWITCHES

**Series-8836-8838
& 8843-8845**

MIL-S-8834 Environmentally Sealed Positive Action Switches

MOUNTING DIMENSIONS - ONE POLE / 8836 SCREW TERMINALS

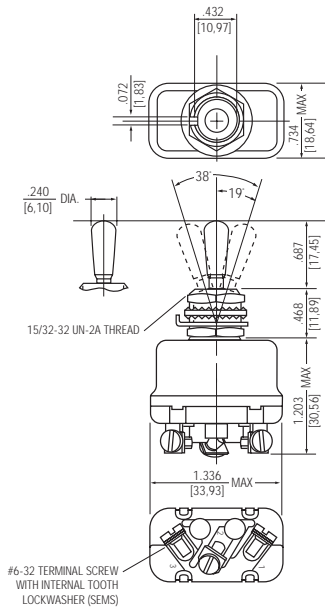

Terminal Identification

MOUNTING DIMENSIONS - TWO POLE / 8837 SCREW TERMINALS

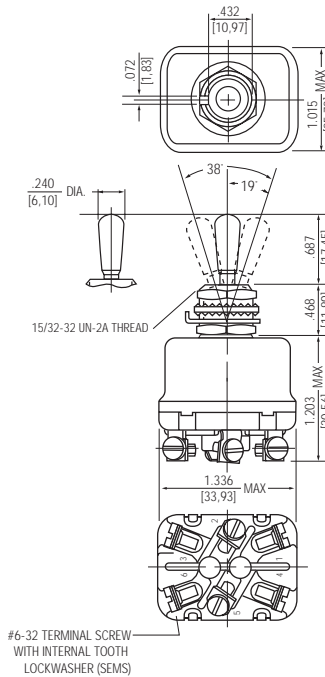

Terminal Identification

STANDARD

0.00 = inches

[0,0] = mm

Mounting dimensions for reference only.

Non-functional terminals not supplied.

ENVIRONMENTALLY SEALED POSITIVE ACTION SWITCHES

**Series-8836-8838
& 8843-8845**

MIL-S-8834 Environmentally Sealed Positive Action Switches

MOUNTING DIMENSIONS - FOUR POLE / 8838 SCREW TERMINALS

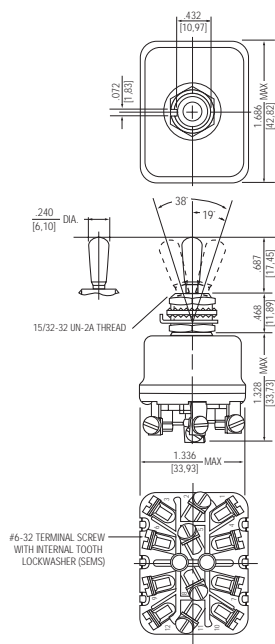

90-2539 AI

Terminal Identification

Non-functional terminals not supplied.

OPTIONS/ACCESSORIES

- Special mounting hardware
- Mounting hardware furnished assembled
- Panel seal, Part Number 32-341
- Terminal screws furnished assembled
- Terminal screws omitted
- Solder lug termination
- Substitute SEMS screws
- Special marking
- Special "3 Cateye" luminous lever attachment - 8836-8838 only
- Lever extensions and attachable tips (See Accessories and Custom Components section)
- Custom wiring harnesses

PANEL CUTOUT DIMENSIONS

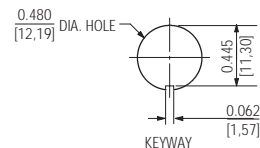
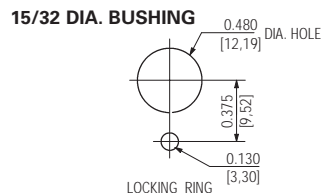

STANDARD

0.00 = inches

[0,0] = mm

Mounting dimensions for reference only.

ENVIRONMENTALLY SEALED POSITIVE ACTION SWITCHES

**Series-8836-8838
& 8843-8845**

MIL-S-8834 Environmentally Sealed Positive Action Switches

MOUNTING DIMENSIONS - ONE POLE / 8836 SOLDER LUG TERMINALS

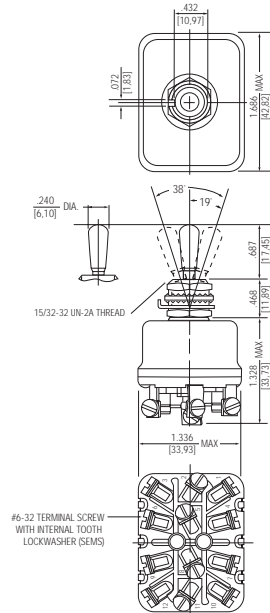

Terminal Identification

MOUNTING DIMENSIONS - TWO POLE / 8837 SOLDER LUG TERMINALS

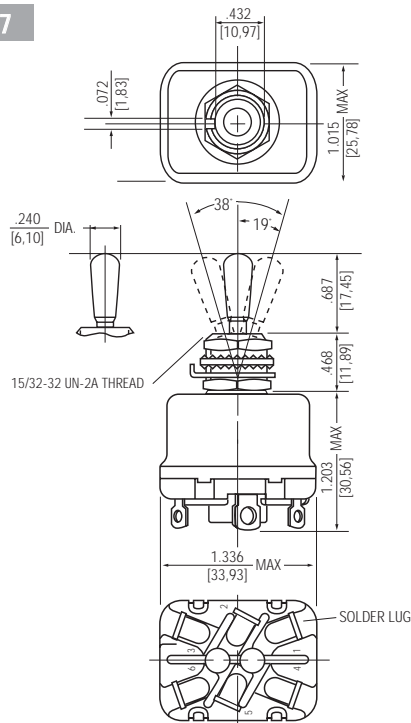

Terminal Identification

STANDARD

0.00 = inches

[0,0] = mm

Mounting dimensions for reference only.

Non-functional terminals not supplied.

ENVIRONMENTALLY SEALED POSITIVE ACTION SWITCHES

**Series-8836-8838
& 8843-8845**

MIL-S-8834 Environmentally Sealed Positive Action Switches Lever Lock

SELECTION TABLE

CIRCUIT WITH LEVER IN . . .

8843



8844



8845



Up Position	Center Position	Down Position (Keyway)	Lever ① Lock Bushing Style	MS Part Number	Catalog Number
ONE POLE					
ON →	← OFF →	← ON	A	MS24612-A212	8843K1
ON	← OFF →	ON	B	-B212	K2
ON	← OFF →	NONE	B	-B242	K16
ON	OFF	← ON	C	-C212	K3
ON	NONE	← OFF	C	-C222	K9
ON	NONE	← ON	C	MS24612-C232	8843K7
ON	← OFF →	ON	D	-D212	K4
ON →	OFF	← ON	E	-E212	K5
ON →	NONE	← OFF	E	-E222	K10
ON →	NONE	← ON	E	-E232	K6
* ON	← OFF →	ON*	F	MS24612-F272	8843K12
ON	OFF →	ON*	G	-G312	K13
* ON	← OFF →	ON*	H	-H272	K14
ON →	← OFF →	NONE	J	-J242	K11
NONE	OFF →	ON*	K	-K282	K15
ON	← OFF →	ON*	K	MS24612-K312	8843K18
ON →	NONE	ON*	L	-L262	K20
ON →	NONE	OFF*	L	-L292	K21
OFF →	NONE	ON*	L	-L302	K19
ON	← OFF →	ON*	M	-M312	K8
ON →	← OFF →	ON*	N	-N312	K17
TWO POLE					
ON →	← OFF →	← ON	A	MS24613-A212	8844K1
ON	← OFF →	ON	B	-B212	K2
ON	← OFF →	NONE	B	-B242	K16
ON	OFF	← ON	C	-C212	K3
ON	NONE	← OFF	C	-C222	K9
ON	NONE	← ON	C	MS24613-C232	8844K7
ON	← OFF →	ON	D	-D212	K4
ON →	OFF	← ON	E	-E212	K5
ON →	NONE	← OFF	E	-E222	K10
ON →	NONE	← ON	E	-E232	K6
* ON	← OFF →	ON*	F	MS24613-F272	8844K12
ON	OFF →	ON*	G	-G312	K13
* ON	← OFF →	ON*	H	-H272	K14
ON →	← OFF →	NONE	J	-J242	K11
NONE	OFF →	ON*	K	-K282	K15
ON	← OFF →	ON*	K	MS24613-K312	8844K18
ON →	NONE	ON*	L	-L262	K20
ON →	NONE	OFF*	L	-L292	K21
OFF →	NONE	ON*	L	-L302	K19
ON	← OFF →	ON*	M	-M312	K8
ON →	← OFF →	ON*	N	-N312	K17
FOUR POLE					
ON →	← OFF →	← ON	A	MS24614-A212	8845K1
ON	← OFF →	ON	B	-B212	K2
ON	← OFF →	NONE	B	-B242	K16
ON	OFF	← ON	C	-C212	K3
ON	NONE	← OFF	C	-C222	K9
ON	NONE	← ON	C	MS24614-C232	8845K7
ON	← OFF →	ON	D	-D212	K4
ON →	OFF	← ON	E	-E212	K5
ON →	NONE	← OFF	E	-E222	K10
ON →	NONE	← ON	E	-E232	K6
* ON	← OFF →	ON*	F	MS24614-F272	8845K12
ON	OFF →	ON*	G	-G312	K13
* ON	← OFF →	ON*	H	-H272	K14
ON →	← OFF →	NONE	J	-J242	K11
NONE	OFF →	ON*	K	-K282	K15
ON	← OFF →	ON*	K	MS24614-K312	8845K18
ON →	NONE	ON*	L	-L262	K20
ON →	NONE	OFF*	L	-L292	K21
OFF →	NONE	ON*	L	-L302	K19
ON	← OFF →	ON*	M	-M312	K8
ON →	← OFF →	ON*	N	-N312	K17

* Momentary contact.

→ Indicates direction against which lever is locked.
See page A75 for circuit diagrams.

① Reference bushing styles on page A45.

ENVIRONMENTALLY SEALED POSITIVE ACTION SWITCHES

**Series-8836-8838
& 8843-8845**

**MIL-S-8834 Environmentally Sealed Positive Action Switches
Lever Lock**

MOUNTING DIMENSIONS - ONE POLE / 8843

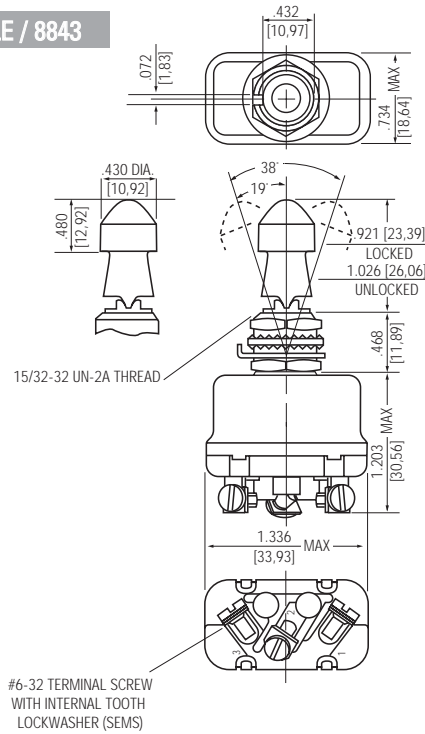

Terminal Identification

MOUNTING DIMENSIONS - TWO POLE / 8844

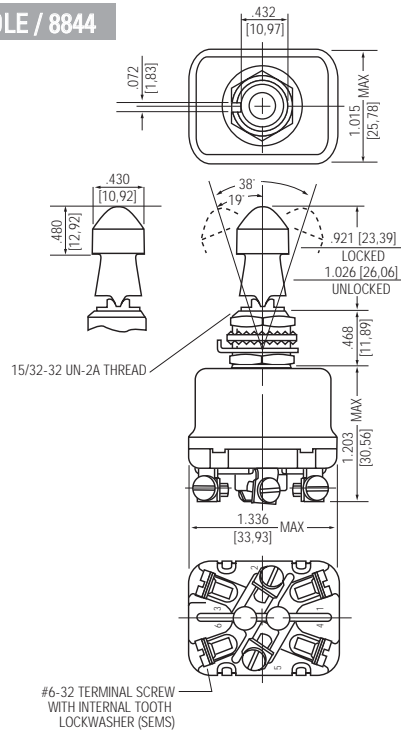

Terminal Identification

STANDARD

0.00 = inches

[0,0] = mm

Mounting dimensions for reference only.

Non-functional terminals not supplied.

ENVIRONMENTALLY SEALED POSITIVE ACTION SWITCHES

**Series-8836-8838
& 8843-8845**

**MIL-S-8834 Environmentally Sealed Positive Action Switches
Lever Lock**

MOUNTING DIMENSIONS - FOUR POLE/ 8845

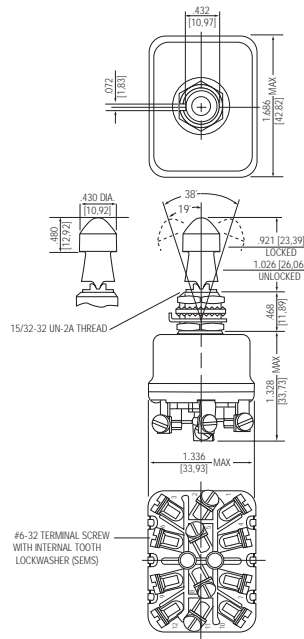

Terminal Identification

Non-functional terminals not supplied.

LEVER LOCK - BUSHING STYLES

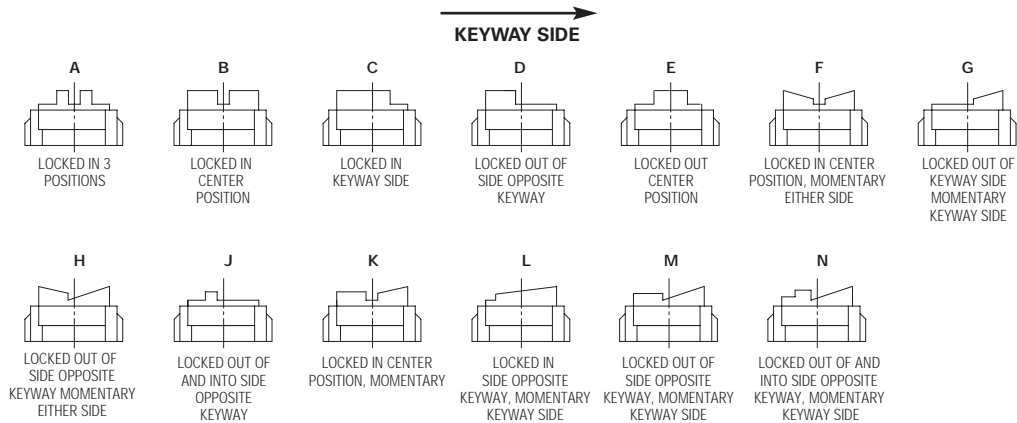

OPTIONS/ACCESSORIES

- Special mounting hardware
- Mounting hardware furnished assembled
- Panel seal, Part Number 32-341
- Terminal screws furnished assembled
- Terminal screws omitted
- Solder lug termination
- Substitute sems screws
- Special marking
- Special "3 Catye" luminous lever attachment - 8836-8838 only
- Lever extensions and attachable tips (See Accessories and Custom Components section)
- Custom wiring harnesses

PANEL CUTOUT DIMENSIONS

15/32 DIA. BUSHING

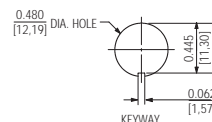
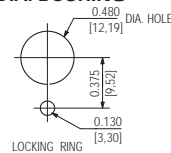

STANDARD

0.00 = inches

[0,0] = mm

Mounting dimensions for reference only.

ENVIRONMENTALLY SEALED POSITIVE ACTION SWITCHES

Series 8836KP-38KP

Flush Mounted Environmentally Sealed Positive Action Switches

FEATURES

- Environmentally Sealed
- High electrical/mechanical reliability
- Non-teasible mechanism
- Wiping action contacts
- Positive make and break action
- Molded-in terminal numbers
- Three hole design for flush mounting
- Dry circuit (logic level loads) to Power Switching levels
- 1,2, and 4 pole circuitry

SPECIFICATIONS

- Environmentally sealed per MILS-8834
- Switch mechanism MS approved and QPL'd per MILS-8834
- Temperature Range: -67°F to 160°F (-55°C to +71°C)
- Life: 20,000 cycles at rated load
40,000 cycles mechanical life
- Positive action mechanism for high reliability and low contact bounce

CURRENT RATINGS

No. of Poles	Catalog Number	Type of Operation	28VDC (Amperes per pole)			115VAC 400Hz (Amperes per pole)			115VAC 60Hz (Amperes per pole)		
			Lamp Load	Resistive Load	Inductive Load	Lamp Load	Resistive Load	Inductive Load	Lamp Load	Resistive Load	Inductive Load
1	8836KP	Maintained and Momentary	7	25	15	7	25	15	7	20	15
2	8837KP	Maintained and Momentary	7	25	15	7	25	15	7	20	15
4	8838KP	Maintained and Momentary	7	25	15	7	25	15	7	20	15

Minimum Rating: 25 microamperes at 5 millivolts.

LEVER LOCK SELECTION TABLE

CIRCUIT WITH LEVER IN . . .

Up Position	Center Position	Down Position (Keyway)	Screw Terminal
			Catalog Number

ONE POLE

8836KP



ON	OFF	ON	8836KP1
ON	NONE	OFF	8836KP9
ON	NONE	ON	8836KP4
ON	NONE	ON*	8836KP5
ON	OFF	ON*	8836KP3
ON*	OFF	ON*	8836KP2
ON	OFF	ON	8836KP1T
ON	NONE	OFF	8836KP9T

TWO POLE

8837KP



ON	OFF	ON	8837KP1
ON	NONE	OFF	8837KP9
ON	NONE	ON	8837KP4
ON	NONE	OFF*	8837KP10
ON*	OFF	ON*	8837KP2
ON	OFF	NONE	8837KP6
ON	OFF	ON*	8837KP3
ON	NONE	ON	8837KP4T
ON	OFF	ON	8837KP1T

FOUR POLE

8838KP



ON	OFF	ON	8838KP31
ON	NONE	ON	8838KP34
ON	OFF	NONE	8838KP36
ON	OFF	ON	8838KP1
ON	NONE	ON	8838KP4
ON	OFF	ON*	8838KP3
ON*	OFF	ON*	8838KP2
ON	OFF	NONE	8838KP6
ON	NONE	ON*	8838KP5

* Momentary contact.

Note: Additional circuit arrangements available.

ENVIRONMENTALLY SEALED POSITIVE ACTION SWITCHES

Series 8836KP-38KP

Flush Mounted Environmentally Sealed Positive Action Switches

MOUNTING DIMENSIONS - ONE POLE / 8836 KP

SCREW TERMINALS

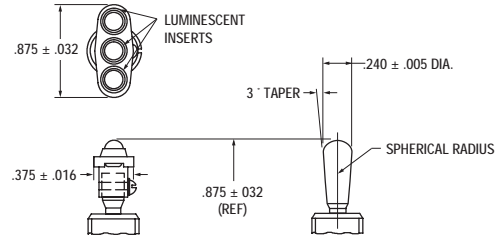
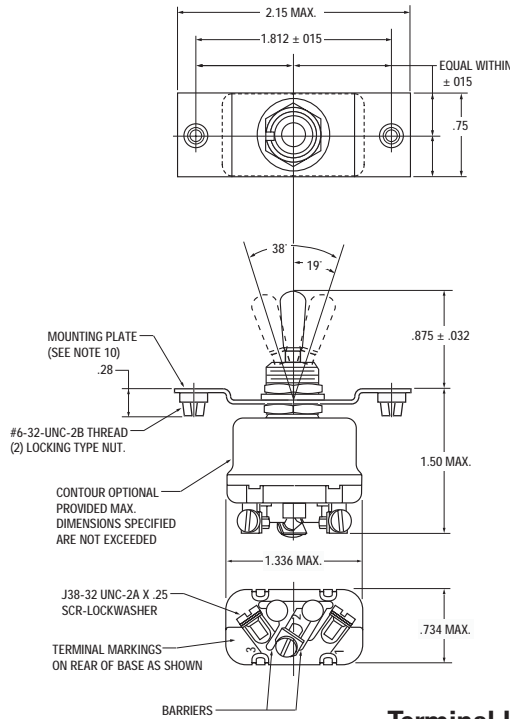

Terminal Identification

MOUNTING DIMENSIONS - TWO POLE / 8837 KP

SCREW TERMINALS

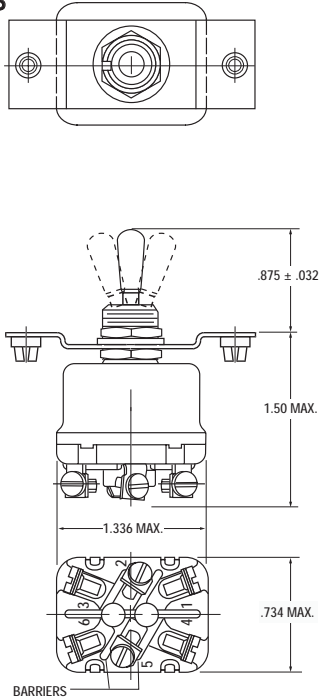

MOUNTING DIMENSIONS - TWO POLE / 8838 KP

SCREW TERMINALS

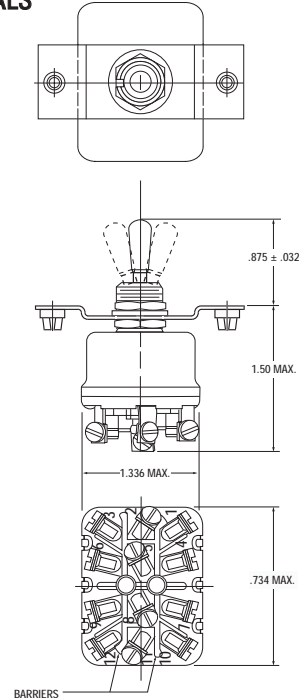

STANDARD
0.00 = inches
[0,0] = mm

Mounting dimensions for reference only.

Non-functional terminals not supplied.

MINIATURE POSITIVE ACTION SWITCHES

Series - 8866-8869

MIL-S-8834 Miniature Positive Action Switches
Solder Lug Terminals

FEATURES

- Sealed bushing
- Current rating versatility
- 1 and 2 pole circuitry
- Non-teasible mechanism for all but center "ON" circuits
- Dry circuit (logic level loads) to power switching levels
- Wiping action contacts
- Positive make and break action
- Small and large size bushings and Actuator
- Solder lug terminals
- Also available with locking Actuator, integrated wire termination and printed circuit board terminals.

SPECIFICATIONS

- Bushing seal or bonded seal per MIL-S-8834
- MS approved and QPL'd to MIL-S-8834
- Temperature range: -67°F to +160°F (-55°C to +71°C)
- Life: 20,000 operations at rated load
40,000 operations mechanical life
- "O" ring panel seal on ¼" - 40 type bushing size
- Solder lug terminals .050 [1,27] dia. hole

CURRENT RATINGS

No. of Poles	Catalog Number	Type of Operation	28 and 50VDC (Amperes per pole)				115VAC 60Hz and 400Hz (Amperes per pole)			
			Resistive Load		Inductive Load		Resistive Load		Inductive Load	
			28VDC	50VDC	28VDC	50VDC	60Hz	400Hz	60Hz	400Hz
1	8866 and 8868	Maintained and Momentary	5	1	1	-	2	3	1	2
2	8867 and 8869	Maintained and Momentary	5	1	1	-	2	3	1	2



Minimum Rating: 25 microamperes at 5 millivolts.

SELECTION TABLE

CIRCUIT WITH LEVER IN . . .

8866



	Up Position 	Center Position 	Down Position (Keyway) 	Military Part Number	Catalog Number ②
ONE POLE					
	ON	OFF	ON	MS24655-211	8866K1
	ON	NONE	OFF	-221	K7
	ON	NONE	ON	-231	K4
	ON	OFF	NONE	-241	K5
	* ON	OFF	ON*	MS24655-271	8866K2
	NONE	OFF	ON*	-281	K6
	ON	OFF	ON*	-311	K3
	NONE	ON	ON*	321	K8Ⓞ
TWO POLE					
	ON	OFF	ON	MS24656-211	8867K1
	ON	NONE	OFF	-221	K7
	ON	NONE	ON	-231	K4
	ON	OFF	NONE	-241	K5
	* ON	OFF	ON*	MS24656-271	8867K2
	NONE	OFF	ON*	-281	K6
	ON	OFF	ON*	-311	K3
	NONE	ON	ON*	MS24656-321	8867K8 Ⓞ
	ON	ON	ON	-331	K9 Ⓞ
	ON	ON	ON*	-351	K10Ⓞ
	* ON	ON	ON*	-341	K11Ⓞ

*** Momentary contact.**

See page A75 for special circuit diagrams.

① Dielectric per MIL-S-8834 except limited to 1250 volts. Delayed action of the switch toggle lever may cause circuit to close or open before snap action mechanism trips.

② Caution should be exercised during soldering and flux removal. See page A56 for details.

MOUNTING DIMENSIONS - ONE POLE / 8866

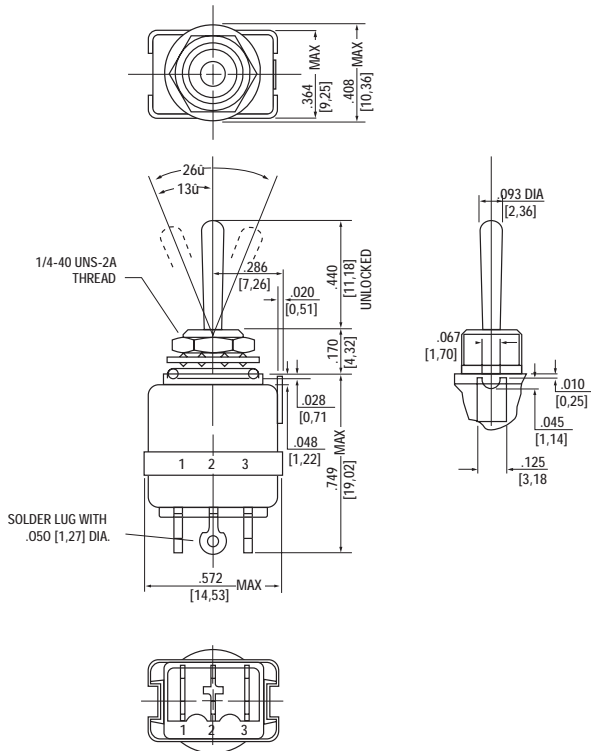

Terminal Identification

MOUNTING DIMENSIONS - TWO POLE / 8867

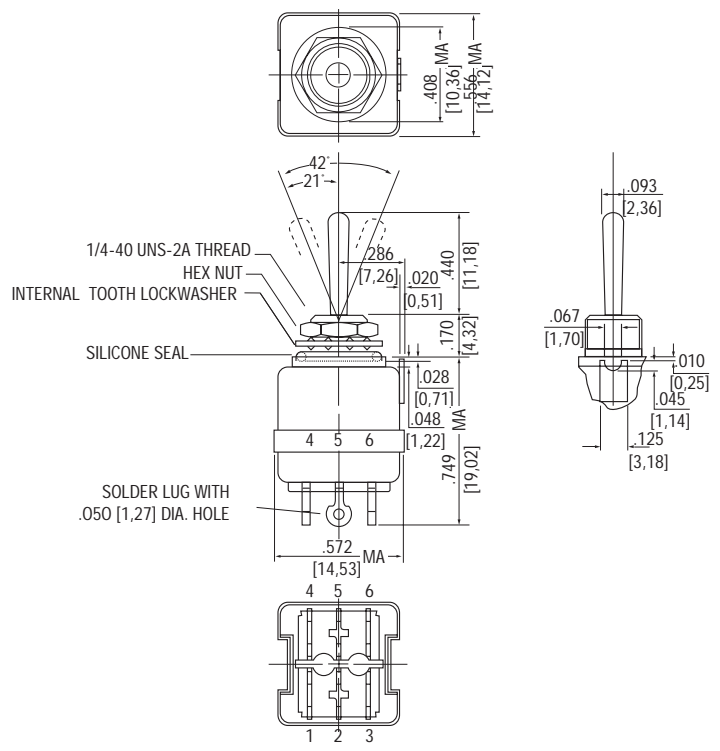

Terminal Identification

Non-functional terminals not supplied.

PANEL CUTOUT DIMENSIONS

1/4 - 40 DIA. BUSHING

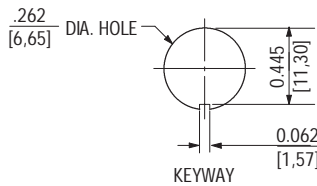
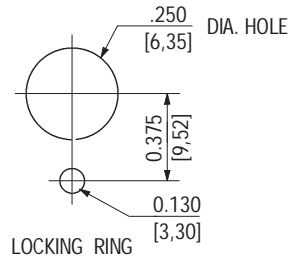

STANDARD

0.00 = inches

[0,0] = mm

Mounting dimensions for reference only.





MINIATURE POSITIVE ACTION SWITCHES

Series - 8866-8869

MIL-S-8834 Miniature Positive Action Switches
Solder Lug Terminals

SELECTION TABLE

CIRCUIT WITH LEVER IN . . .

	Up Position 	Center Position 	Down Position (Keyway) 	MS Part Number	Catalog Number ②	MS Part Number ③	Catalog Number ②	
ONE POLE								
8868 	ON	OFF	ON	MS90310-211	8868K1	Feature Not Available in Single Pole Switches		
	ON	NONE	OFF	-221	K7	—	—	
	ON	NONE	ON	-231	K4	—	—	
	ON	OFF	NONE	-241	K5	—	—	
	* ON	OFF	ON*	MS90310-271	8868K2	—	—	
	NONE	OFF	ON*	-281	K6	—	—	
	ON	OFF	ON*	-311	K3	—	—	
	NONE	ON	ON*	MS21351-321	K8①	—	—	
	TWO POLE							
	8869 	ON	OFF	ON	MS90311-211	8869K1	MS90311-711	8869K1X
ON		NONE	OFF	-221	K7	-721	K7X	
ON		NONE	ON	-231	K4	-731	K4X	
ON		OFF	NONE	-241	K5	-741	K5X	
* ON		OFF	ON*	MS90311-271	8869K2	MS90311-771	8869K2X	
NONE		OFF	ON*	-281	K6	-781	K6X	
ON		OFF	ON*	-311	K3	-811	K3X	
NONE		ON	ON*	MS21353-321	8869K8 ①	MS21353-821	8869K8X①	
ON		ON	ON	-331	K9 ①	-831	K9X①	
ON		ON	ON*	-351	K10 ①	-851	K10X①	
* ON		ON	ON*	-341	K11 ①	-841	K11X①	

* **Momentary contact.**

① Dielectric per MIL-S-8834 except limited to 1250 volts. Delayed action of the switch toggle lever may cause circuit to close or open before snap action mechanism trips.

② Caution should be exercised during soldering and flux removal. See page A56 for details.

③ Furnished with Bonded Seal Feature. (Meets 15' water sealing level requirements.)

MINIATURE POSITIVE ACTION SWITCHES

Series - 8866-8869

MIL-S-8834 Miniature Positive Action Switches Solder Lug Terminals

MOUNTING DIMENSIONS - ONE POLE / 8868

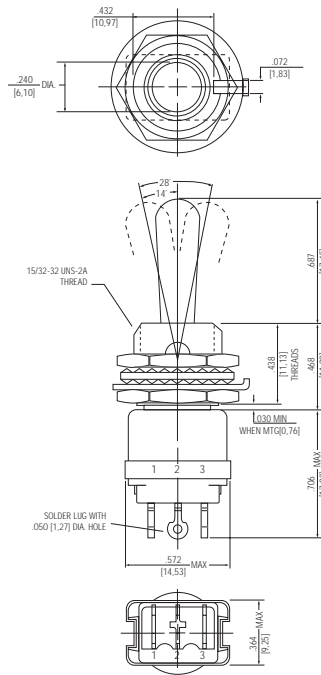

Terminal Identification

MOUNTING DIMENSIONS - TWO POLE / 8869

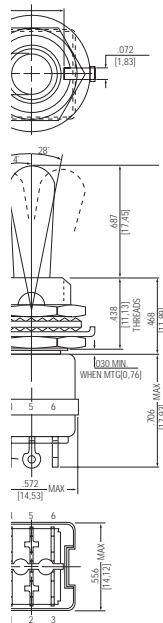

Terminal Identification

STANDARD

0.00 = inches

[0,0] = mm

Mounting dimensions for reference only.

Non-functional terminals not supplied.

MINIATURE POSITIVE ACTION SWITCHES

Series - 8866-8869

MIL-S-8834 Miniature Positive Action Switches
Solder Lug Terminals

OPTIONS/ACCESSORIES

- Special mounting hardware
- Special marking
- Mounting hardware furnished assembled
- Panel seal, Part Number 32-341
- Lever extensions and attachable tips
- Special circuits
- Special bushing and lever plating
- Mounting adapter nuts
- Custom wire harnesses
- EMI/RFI capability on two pole (large bushing)
- Gold plated contacts

PANEL CUTOUT DIMENSIONS

15/32 DIA. BUSHING

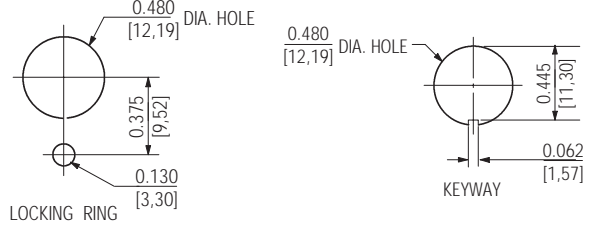

STANDARD

0.00 = inches

[0,0] = mm

Mounting dimensions for reference only.

See page A56 for soldering and cleaning recommendations.

FEATURES

- Sealed bushing
- Dry circuit (logic level loads) to power switching levels
- Two bushing and toggle lever sizes
- 1 and 2 pole circuitry
- Non-teasible mechanism for all but center "ON" circuits
- Wiping action contacts
- Positive make and break action
- Small and large size bushings and Actuator
- Printed circuit board termination
- Two types of printed circuit board terminals:
 - Straight
 - Formed (Right Angle)

SPECIFICATIONS

- Bushing seal or bonded seal per MIL-S 8834
- MS approved and QPL'd to MIL-S-8834
- Temperature range: -67°F to +160°F (-55°C to +71°C)
- Life: 20,000 operations at rated load
40,000 operations mechanical life
- "O" ring panel seal on ¼" - 40 type bushing size



CURRENT RATINGS

No. of Poles	Catalog Number	Type of Operation	28 and 50VDC (Amperes per pole)				115VAC 60Hz and 400Hz (Amperes per pole)			
			Resistive Load		Inductive Load		Resistive Load		Inductive Load	
			28VDC	50VDC	28VDC	50VDC	60Hz	400Hz	60Hz	400Hz
1	8866 and 8868	Maintained and Momentary	5	1	1	-	2	3	1	2
2	8867 and 8869	Maintained and Momentary	5	1	1	-	2	3	1	2

Minimum Rating: 25 microamperes at 5 millivolts.

SELECTION TABLE

CIRCUIT WITH LEVER IN . . .

	Up Position	Center Position	Down Position (Keyway)	Small Lever With Straight Mount PC Terminals		Small Lever With Formed Mount PC Terminals		Small Lever With Straight Mount PC Terminals			
				MS Part Number	Catalog ^② Number	MS Part Number	Catalog ^② Number	MS Part Number	Catalog ^② Number	MS Part ^③ Number	Catalog ^② Number
One Pole											
	ON	OFF	ON	MS21354-211	8866K61	MS21433-211	8866KA61	MS21356-211	8868K61	Feature Not Available in Single Pole Switches	
	ON	NONE	OFF	-221	K67	-221	KA67	-221	K67		
	ON	NONE	ON	-231	K64	-231	KA64	-231	K64		
	ON	OFF	NONE	-241	K65	-241	KA65	-241	K65		
	* ON	OFF	ON*	MS21354-271	8866K62	MS21433-271	8866KA62	MS21356-271	8868K62		
	NONE	OFF	ON*	-281	K66	-281	KA66	-281	K66		
	ON	OFF	ON*	-311	K63	-311	KA63	-311	K63		
	NONE	ON	ON*	-321	K68 [Ⓣ]	-321	KA68 [Ⓣ]	-321	K68 [Ⓣ]		
Two Pole											
	ON	OFF	ON	MS21355-211	8867K61	MS21434-211	8867KA61	MS21357-211	8869K61	MS21357-711	8869K61X
	ON	NONE	OFF	-221	K67	-221	KA67	-221	K67	-721	K67X
	ON	NONE	ON	-231	K64	-231	KA64	-231	K64	-731	K64X
	ON	OFF	NONE	-241	K65	-241	KA65	-241	K65	-741	K65X
	* ON	OFF	ON*	MS21355-271	8867K62	MS21434-271	8867KA62	MS21357-271	8869K62	MS21357-771	8869K62X
	NONE	OFF	ON*	-281	K66	-281	KA66	-281	K66	-781	K66X
	ON	OFF	ON*	-311	K63	-311	KA63	-311	K63	-811	K63X
	NONE	ON	ON*	MS21355-321	8867K68 [Ⓣ]	MS21434-321	8867KA68 [Ⓣ]	MS21357-321	8869K68 [Ⓣ]	MS21357-821	8869K68X [Ⓣ]
	ON	ON	ON	-331	K69 [Ⓣ]	-331	KA69 [Ⓣ]	-331	K69 [Ⓣ]	-831	K69X [Ⓣ]
	ON	ON	ON*	-351	K610 [Ⓣ]	-351	KA610 [Ⓣ]	-351	K610 [Ⓣ]	-851	K610X [Ⓣ]
	* ON	ON	ON*	-341	K611 [Ⓣ]	-341	KA611 [Ⓣ]	-341	K611 [Ⓣ]	-841	K611X [Ⓣ]

* **Momentary contact.**

See page A75 for special circuit diagrams.

- ① Dielectric per MIL-S-8834 except limited to 1250 volts. Delayed action of the switch toggle lever may cause circuit to close or open before snap action mechanism trips.
- ② Caution should be exercised during soldering and flux removal. See page A56 for details.
- ③ Furnished with Bonded Seal Feature. (Meets 15' water sealing level requirement.)

MINIATURE POSITIVE ACTION SWITCHES

Series - 8866, 8867, 8868, 8869

MIL-S-8834 Miniature Positive Action Switches Printed Circuit Terminals

MOUNTING DIMENSIONS - ONE POLE

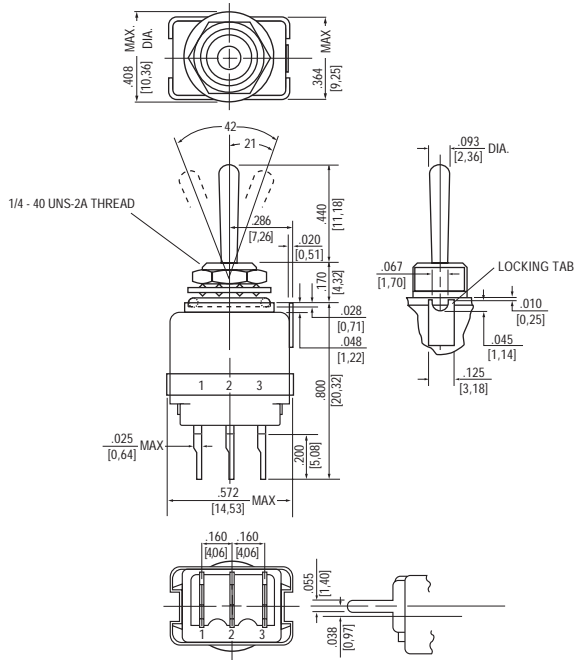

8866
Straight PC Mount

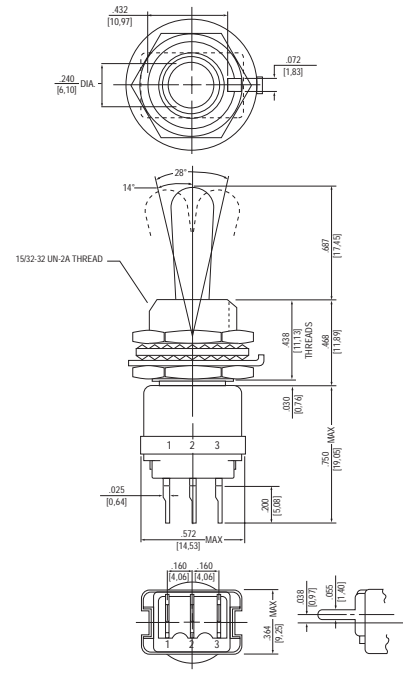

8868
Straight PC Mount

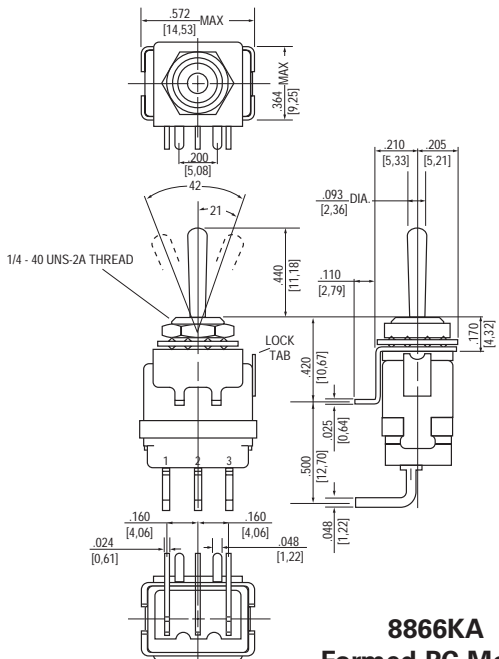

8866KA
Formed PC Mount

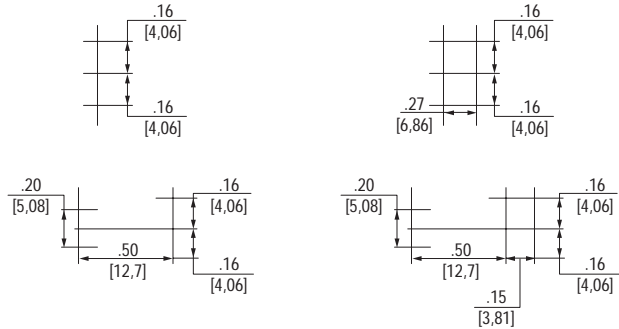

STANDARD

0.00 = inches

[0,0] = mm

Terminal Identification

Mounting dimensions for reference only.

Non-functional terminals not supplied.

MOUNTING DIMENSIONS - TWO POLE

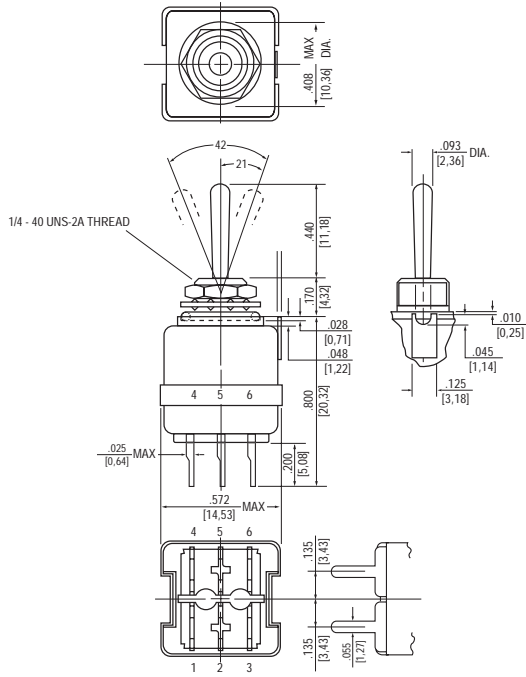

8867
Straight PC Mount

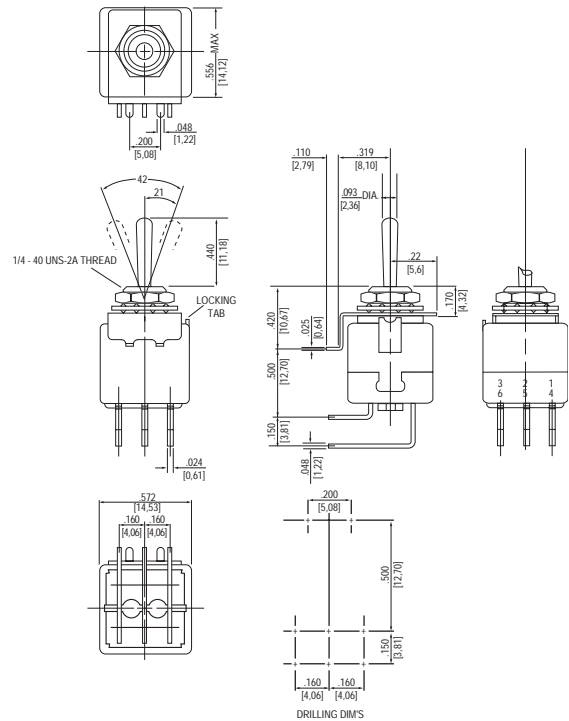

8867KA
Formed PC Mount

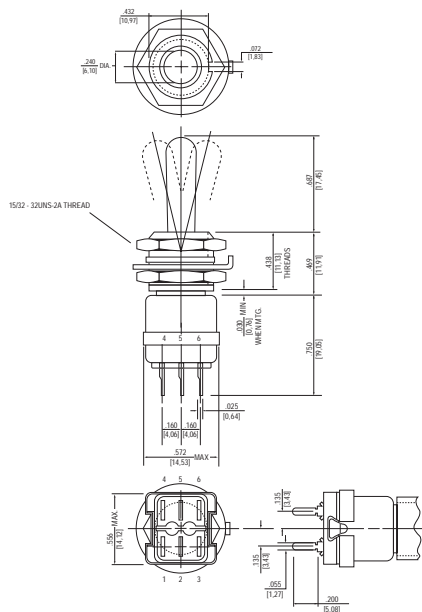

8869
Straight PC Mount

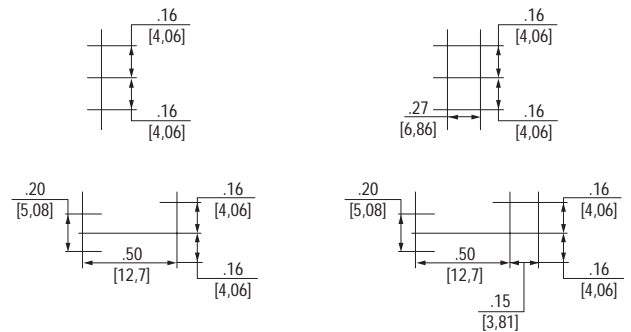

STANDARD
0.00 = inches
[0,0] = mm

Terminal Identification

Mounting dimensions for reference only.

Non-functional terminals not supplied.

MINIATURE POSITIVE ACTION SWITCHES

Series - 8866, 8867, 8868, 8869

MIL-S-8834 Miniature Positive Action Switches
Printed Circuit Terminals

CAUTION AND RECOMMENDATION FOR CLEANING AND SOLDERING

Contamination of the contacts of miniature switches is the most common cause of problems in low energy circuits, resulting in the inability of current to flow through the increased resistance of the switch contacts. As most contamination occurs during the installation and cleaning of the switch, proper care when installing the switch can reduce problems in this area. The following procedures should be followed to reduce the possibility of switch contact contamination.

Hand Solder

1. Use rosin core solder .030"-.040" diameter.
2. A small soldering iron in the 30 to 40 watt range should be used.
3. The solder joint should not be overheated.
4. Do not position switch with terminations straight up.
5. No clean up should be necessary. However, if used, do not allow solvents to enter non-sealed areas of switches.

Wave Solder - Miniature Switches

Do not immerse or spray with solvents to remove flux except for switches designed for this type of cleaning. The use of wave solder oil is not advised.

OPTIONS/ACCESSORIES

- Special mounting hardware
- Special marking
- Mounting hardware furnished assembled
- Panel seal, Part Number 32-341 (15/32" - 32 bushing only)
- Special circuits
- Special bushing and lever plating
- Mounting adapter nut
- Custom wire harnesses
- EMI/RFI capability on two pole (15/32" - 32 bushing only)
- Gold plated contacts

PANEL CUTOUT DIMENSIONS

15/32 DIA. BUSHING

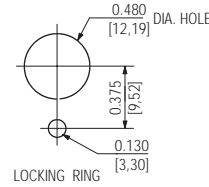

1/4 - 40 DIA. BUSHING

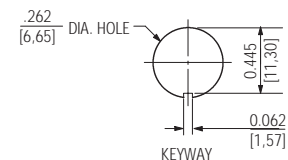
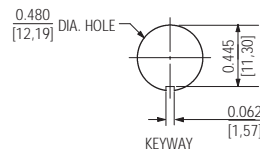
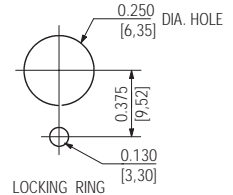

MINIATURE POSITIVE ACTION SWITCHES

Series - 8855, 8856

MIL-S-8834 Miniature Positive Action Switches Lever Lock/Solder Lug Terminals

FEATURES

- Sealed bushing
- Dry circuit (logic level loads) to power switching levels
- 1 and 2 pole circuitry
- Non-teasible mechanism for all but center "ON" circuits
- High electrical/ mechanical reliability
- Two styles of lever lock Actuator
- Locking actuator for safety
- Wiping action contacts
- Positive make and break action
- Solder lug termination

SPECIFICATIONS

- Bushing seal or bonded seal per MIL-S-8834
- MS approved and QPL'd to MIL-S-8834
- Temperature Range: -67°F to +160°F (-55°C to +71°C)
- Life: 20,000 operations at rated load
40,000 operations mechanical life
- Solder lug terminal .050 [1,27] dia.hole

CURRENT RATINGS

No. of Poles	Catalog Number	Type of Operation	28 and 50VDC (Amperes per pole)				115VAC 60Hz and 400Hz (Amperes per pole)			
			Resistive Load		Inductive Load		Resistive Load		Inductive Load	
			28VDC	50VDC	28VDC	50VDC	60Hz	400Hz	60Hz	400Hz
1	8855	Maintained and Momentary	5	1	1	-	2	3	1	2
2	8856	Maintained and Momentary	5	1	1	-	2	3	1	2

Minimum Rating: 25 microamperes at 5 millivolts.

STANDARD CAP STYLE

MUSHROOM CAP STYLE



8855



8856



8855



8856

SELECTION TABLE

CIRCUIT WITH LEVER IN ...

Up Position	Center Position	Down Position (Keyway)	Lever Lock® Bushing Style	MS Part Number	Catalog Number	MS® Part Number	Catalog® Number	MS Part Number	Catalog Number	MS Part® Number	Catalog® Number
ONE POLE											
ON →	← OFF →	← ON	A	MS21026-A211	8855K4	Feature Not Available in Single Pole Switches		MS21436-A211	8855K74	Feature Not Available in Single Pole Switches	
ON	← OFF →	ON	B	-B211	K5			-B211	K75		
ON	← OFF →	NONE	B	-B241	K19			-B241	K719		
ON	NONE	← ON	C	-C221	K13			-C221	K713		
ON	NONE	← ON	C	-C231	K7			-C231	K77		
ON	← OFF →	ON	D	MS21026-D211	8855K10			MS21436-D211	8855K710		
ON →	NONE	← OFF	E	-E221	K14			-E221	K714		
ON →	NONE	← ON	E	-E231	K8			-E231	K78		
* ON	← OFF →	ON*	F	-F271	K15			-F271	K715		
ON	← OFF →	ON*	G	-G311	K16			-G311	K716		
* ON	← OFF →	ON*	H	MS21026-H271	8855K17			MS21436-H271	8855K717		
ON →	← OFF →	NONE	J	-J241	K9			-J241	K79		
NONE	← OFF →	ON*	K	-K281	K18			-K281	K718		
ON	← OFF →	ON*	K	-K311	K20			-K311	K720		
ON	← OFF →	ON*	L	-L311	K12			-L311	K712		
TWO POLE											
ON →	← OFF →	← ON	A	MS21027-A211	8856K4	MS21027-A711	8856K4X	MS21437-A211	8856K74	MS21437-A711	8856K74X
ON	← OFF →	ON	B	-B211	K5	-B711	K5X	-B211	K75	-B711	K75X
ON	← OFF →	NONE	B	-B241	K19	-B741	K19X	-B241	K719	-B741	K719X
ON	NONE	← OFF	C	-C221	K13	-C721	K13X	-C221	K713	-C721	K713X
ON	NONE	← ON	C	-C231	K7	-C731	K7X	-C231	K77	-C731	K77X
ON	← OFF →	ON	D	MS21027-D211	8856K10	MS21027-D711	8856K10X	MS21437-D211	8856K710	MS21437-D711	8856K710X
ON →	NONE	← OFF	E	-E221	K14	-E721	K14X	-E221	K714	-E721	K714X
ON →	NONE	← ON	E	-E231	K8	-E731	K8X	-E231	K78	-E731	K78X
* ON	← OFF →	ON*	F	-F371	K27	-F871	K27X	-F371	K727	-F871	K727X
ON	← OFF →	ON*	G	-G311	K16	-G811	K16X	-G311	K716	-G811	K716X
* ON	← OFF →	ON*	H	MS21027-H371	8856K29	MS21027-H871	8856K29X	MS21437-H371	8856K729	MS21437-H871	8856K729X
ON →	← OFF →	NONE	J	-J241	K9	-J741	K9X	-J241	K79	-J741	K79X
NONE	← OFF →	ON*	K	-K381	K28	-K881	K28X	-K381	K728	-K881	K728X
ON	← OFF →	ON*	K	-K311	K20	-K811	K20X	-K311	K720	-K811	K720X
ON	← OFF →	ON*	L	-L311	K12	-L811	K12X	-L311	K712	-L811	K712X
ON →	← ON →	← ON	A	MS21027-A331	8856K21⊕	MS21027-A831	8856K21X⊕	MS21437-A331	8856K721⊕	MS21437-A831	8856K721X⊕
ON	← ON →	ON	B	-B331	K30⊕	-B831	K30X⊕	-B331	K730⊕	-B831	K730X⊕
ON	ON	← ON	C	-C331	K31⊕	-C831	K31X⊕	-C331	K731⊕	-C831	K731X⊕
ON	← ON	ON	D	-D331	K32⊕	-D831	K32X⊕	-D331	K732⊕	-D831	K732X⊕
* ON	← ON →	ON*	F	-F341	K22⊕	-F841	K22X⊕	-F341	K722⊕	-F841	K722X⊕
* ON	← ON →	ON*	H	MS21027-H341	8856K34⊕	MS21027-H841	8856K34X⊕	MS21437-H341	8856K734⊕	MS21437-H841	8856K734X⊕
NONE	ON →	ON*	K	-K321	K24⊕	-K821	K24X⊕	-K321	K7241⊕	-K821	K724X⊕
ON	ON →	ON*	G	-G351	K35⊕	-G851	K35X⊕	-G351	K735⊕	-G851	K735X⊕
ON	← ON →	ON*	K	-K351	K23⊕	-K851	K23X⊕	-K351	K723⊕	-K851	K723X⊕
ON	← ON →	ON	L	-L351	K36⊕	-L851	K36X⊕	-L351	K736⊕	-L851	K736X⊕

* Momentary contact.

→ Indicates direction against which lever is locked.

See page A75 for special circuit diagrams.

⊕ Dielectric per MIL-S-8834 except limited to 1250 volts. Delayed action of the switch toggle lever may cause circuit to close or open before snap action mechanism trips.

⊗ Furnished with Bonded Seal Feature. (Meets with 15' head of water level requirement.)

Ⓜ Not military MS approved.

Ⓜ Reference bushing styles on page A59.

MINIATURE POSITIVE ACTION SWITCHES

Series - 8855, 8856

MIL-S-8834 Miniature Positive Action Switches
Lever Lock/Solder Lug Terminals

MOUNTING DIMENSIONS - ONE POLE / 8855

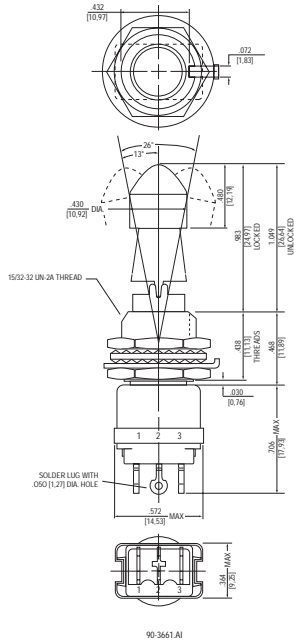

Standard Cap Style

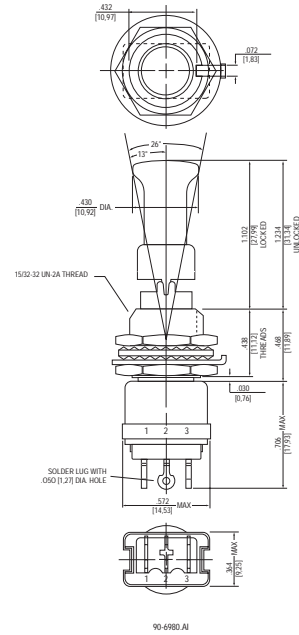

Mushroom Cap Style

Terminal Identification

MOUNTING DIMENSIONS - TWO POLE / 8856

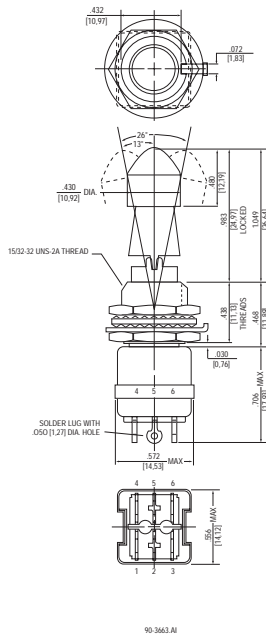

Standard Cap Style

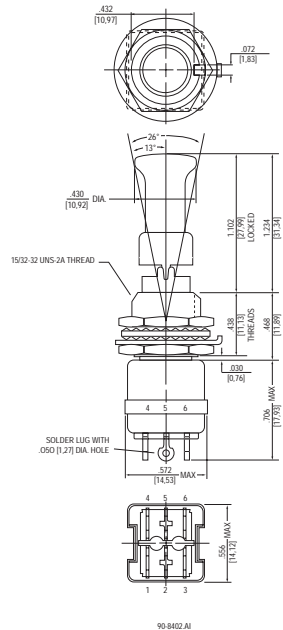

Mushroom Cap Style

Terminal Identification

STANDARD
0.00 = inches
[0,0] = mm

Mounting dimensions for reference only.

Non-functional terminals not supplied.

OPTIONS/ACCESSORIES

- Special mounting hardware
- Special marking
- Mounting hardware furnished assembled
- Special locking configurations
- Panel seal, Part Number 32-341
- Special circuits
- Special locking cap style
- Custom wire harnesses
- EMI/RFI capability on two pole

LEVER LOCK - BUSHING STYLES

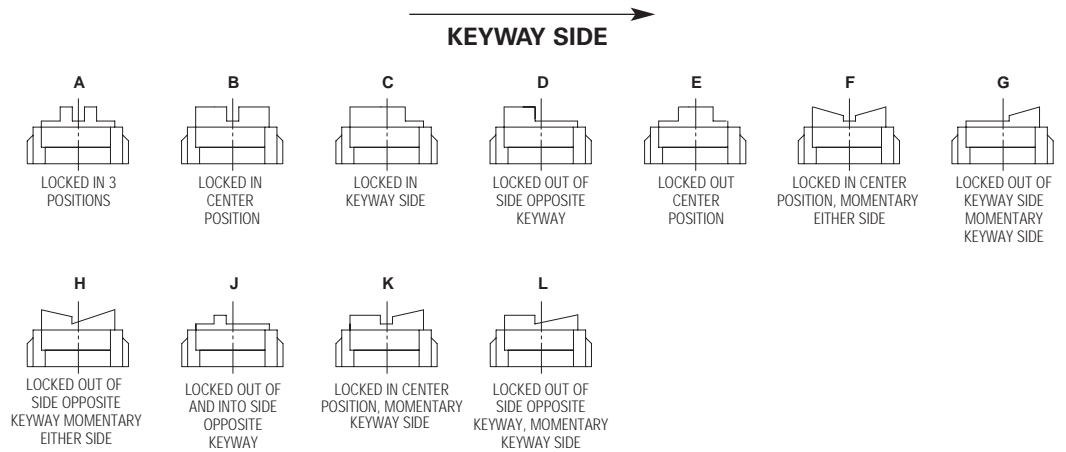

OPTIONS/ACCESSORIES

- Special mounting hardware
- Special marking
- Mounting hardware furnished assembled
- Special locking configurations
- Panel seal, Part Number 32-341
- Special circuits
- Special locking cap style
- Custom wire harnesses
- EMI/RFI capability on two pole
- Gold plated contacts

PANEL CUTOUT DIMENSIONS

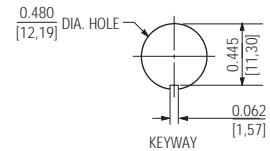
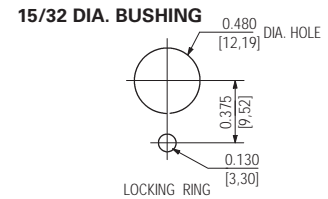

MINIATURE POSITIVE ACTION SWITCHES

Series - 8855, 8856, 8866-69

MIL-S-8834 Miniature Positive Action Switches
Toggle and Lever Lock/IWTS Terminals

FEATURES		SPECIFICATIONS		CURRENT RATINGS								
<ul style="list-style-type: none"> Sealed bushing Dry circuit (logic level loads) to power switching levels 1 and 2 pole circuitry Non-teasible mechanism for all but center "ON" circuit Small and large size bushings and Actuator Toggle and lever lock Actuator Wiping action contacts Positive make and break action Integrated Wire Termination System (IWTS) 	<ul style="list-style-type: none"> Bushing seal or bonded seal per MILS-8834 MS approved and QPL listed to MILS-8834 Temperature Range: -67°F to +160°F (-55°C to +71°C) Life: 20,000 operations at rated load, 40,000 operations mechanical life Bushing thread sizes: Small Toggle: ¼" - 40 thread Large Toggle and Lever Lock: 15/32" - 32 thread Accepts MIL-C-39029/1 Pin (pins not included) 	No. of Poles	Catalog Number	Type of Operation	28 and 50VDC (Amperes per pole)				115VAC 60Hz and 400Hz (Amperes per pole)			
					Resistive Load		Inductive Load		Resistive Load		Inductive Load	
					28VDC	50VDC	28VDC	50VDC	60Hz	400Hz	60Hz	400Hz
		1	8855 8866 8868	Maintained and Momentary	5	1	1	-	2	3	1	2
		2	8856 8867 8869	Maintained and Momentary	5	1	1	-	2	3	1	2
Minimum Rating: 25 microamperes at 5 millivolts.												

SELECTION TABLE

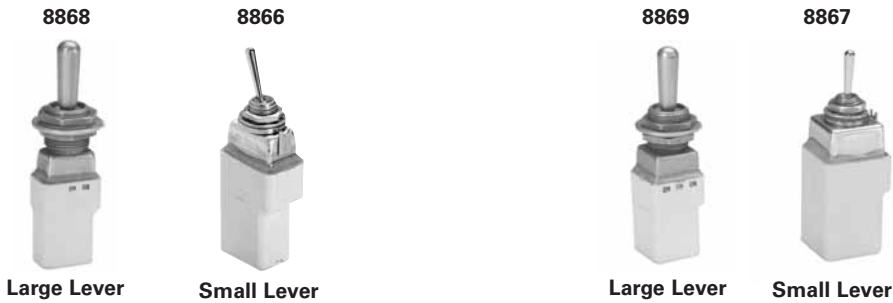

CIRCUIT WITH LEVER IN . . .			ONE POLE				TWO POLE					
Up Position	Center Position	Down Position (Keyway)	MS Part Number	Catalog Number	MS Part Number	Catalog Number	MS Part Number	Catalog Number	MS Part Number	Catalog Number	MS Part Number	Catalog Number
				Large Lever		Small Lever		Large Lever		Small Lever		
ON	OFF	ON	MS21346-211	8868K51	MS24655-211W	8866K51	MS21347-211	8869K51	MS24656-211W	8867K51	MS21347-711	8869K51X
ON	NONE	OFF	-221	K57	-221W	K57	-221	K57	-221W	K57	-721	K57X
ON	NONE	ON	-231	K54	-231W	K54	-231	K54	-231W	K54	-731	K54X
ON	OFF	NONE	-241	K55	-241W	K55	-241	K55	-241W	K55	-741	K55X
ON	OFF	ON	MS21346-271	8868K52	-271W	8866K52	MS21347-271	8869K52	-271W	8867K52	MS21347-771	8869K52X
NONE	OFF	ON*	-281	K56	-281W	K56	-281	K56	-281W	K56	-781	K56X
ON	OFF	ON*	-311	K53	-311W	K53	-311	K53	-311W	K53	-811	K53X
NONE	ON	ON*	MS21346-321	K58 [Ⓣ]	-321W	K58 [Ⓣ]	MS21347-321	8869K58 [Ⓣ]	-321W	8867K58 [Ⓣ]	MS21347-821	8869K58X [Ⓣ]
ON	ON	ON	-	-	-331W	-	-331	K59 [Ⓣ]	-331W	K59 [Ⓣ]	-831	K59X [Ⓣ]
ON	ON	ON*	-	-	-351W	-	-351	K510 [Ⓣ]	-351W	K510 [Ⓣ]	-851	K510X [Ⓣ]
ON	ON	ON	-	-	-341W	-	-341	K511 [Ⓣ]	-341W	K511 [Ⓣ]	-841	K511X [Ⓣ]

* Momentary contact.

Ⓣ Dielectric per MILS-8834 except limited to 1250 volts. Delayed action of the switch toggle lever may cause circuit to close or open before snap action mechanism trips.

Ⓣ Furnished with Bonded Seal feature. (Meets 15' head of water level requirement.)

SELECTION TABLE



8855



8856

CIRCUIT WITH LEVER IN . . .

ONE POLE

TWO POLE

Up Position	Center Position	Down Position (Keyway)	Lever Lock Bushing Style	MS Part Number	Catalog Number	MS Part Number	Catalog Number
ON →	← OFF →	← ON	A	MS21346-A211	8855K54	MS21347-A211	8856K54
ON	← OFF →	ON	B	-B211	K55	-B211	K55
ON	← OFF	NONE	B	-B241	K519	-B241	K519
ON	NONE	← OFF	C	-C221	K513	-C221	K513
ON	NONE	← ON	C	-C231	K57	-C231	K57
ON	← OFF	ON	D	MS21346-D211	8855K510	MS21347-D211	8856K510
ON →	NONE	← OFF	E	-E221	K514	-E221	K514
ON →	NONE	← ON	E	-E231	K58	-E231	K58
* ON	← OFF →	ON*	F	-F271	K515	-E271	K515
ON	OFF →	ON*	G	-G311	K516	-G311	K516
* ON	← OFF	ON*	H	MS21346-H271	8855K517	MS21347-H271	8856K517
ON →	← OFF	NONE	J	-J241	K59	-J241	K59
NONE	OFF →	ON*	K	-K281	K518	-K281	K518
ON	← OFF →	ON*	K	-K311	K520	-K311	K520
ON	← OFF	ON*	L	-L311	K512	-L311	K512

* Momentary contact.

→ Indicates direction against which lever is locked.
See page A75 for special circuit diagrams.

OPTIONS/ACCESSORIES

- Special mounting hardware
- Special marking
- Mounting hardware furnished assembled
- Panel seal, Part Number 32-341 (15/32" - 32 bushing only)
- Special circuits
- Special bushing and lever finish
- Special locking cap style on lever lock switches
- EMI/RFI capability on two pole (15/32" - 32 bushing only)

LEVER LOCK - BUSHING STYLES

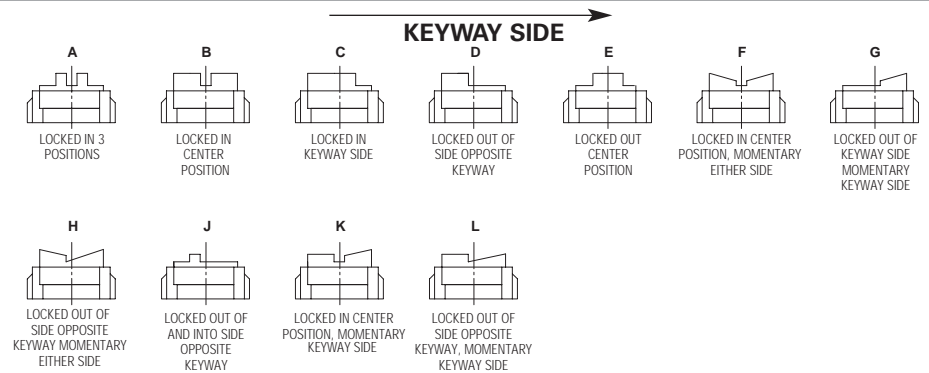

PANEL CUTOUT DIMENSIONS

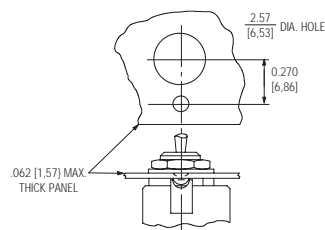
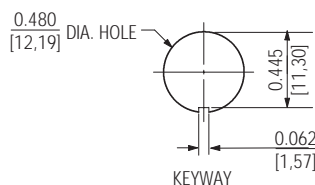
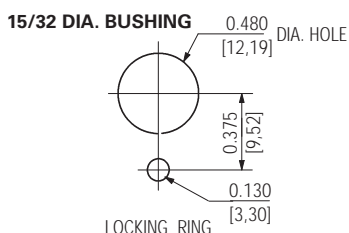

MINIATURE POSITIVE ACTION SWITCHES

Series - 8855, 8856, 8866-69

MIL-S-8834 Miniature Positive Action Switches
Toggle and Lever Lock/IWTS Terminals

MOUNTING DIMENSIONS - ONE POLE / 8855, 8866, 8868

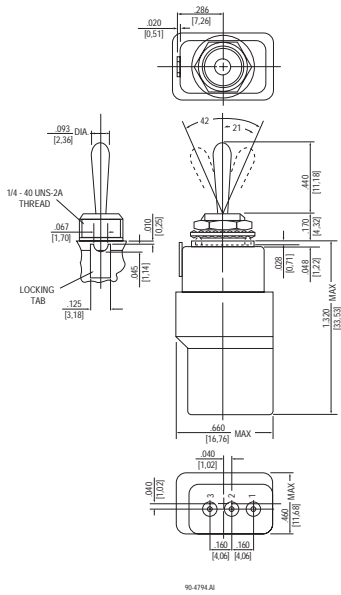

Small Toggle

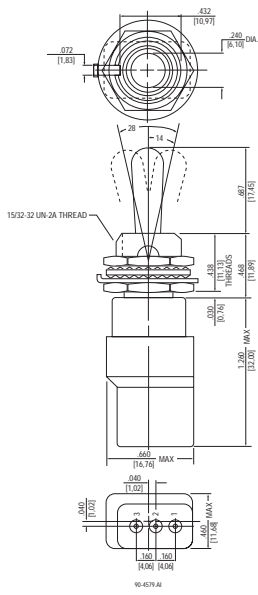

Large Toggle/ Terminal Identification

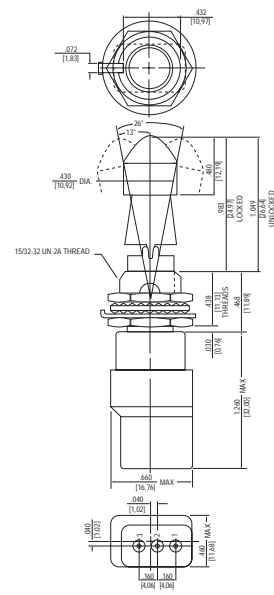

Lever Lock

MOUNTING DIMENSIONS - TWO POLE / 8856, 8867, 8869

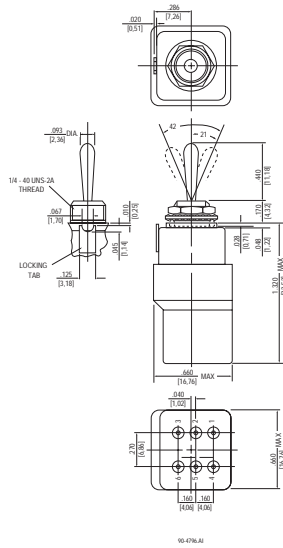

Small Toggle

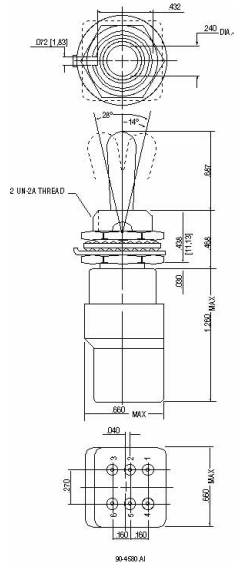

Large Toggle/ Terminal Identification

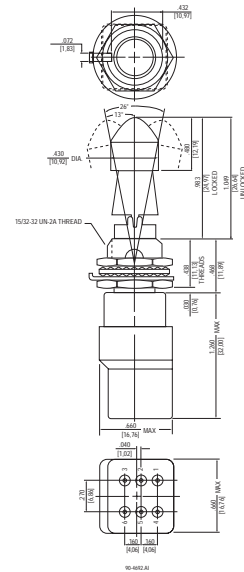

Lever Lock

STANDARD

0.00 = inches

[0,0] = mm



Mounting dimensions for reference only.

FEATURES		SPECIFICATIONS		CURRENT RATINGS				
<ul style="list-style-type: none"> Made to MIL-DTL-8834 Requirements Sealed bushing Current rating versatility 4 pole circuitry (Maintained & Momentary variations) Non-teasible mechanism for all but center "on" position Dry circuit (logic loads loads) to power switching levels Wiping action contacts Positive make and break action 11/16" Lever Length & 15/32" bushing Dia. Solder-lug terminals 	<ul style="list-style-type: none"> Bushing seal per MIL-DTL-8834 Meets 0.5" Head of Water Temperature Range: -22°F to +149°F -30°C to +65°C Electrical Life: 20,000 Operations at rated load Mechanical Life: 40,000 Operations 	No. of Poles	Catalog Number	Type of Operation	28 and 50VDC (Amperes per pole)		115VAC 60Hz and 400Hz (Amperes per pole)	
					Resistive Load 28VDC	Inductive Load 28VDC	Resistive Load 60Hz 400Hz	Inductive Load 60Hz 400Hz
		4	8854	Maintained & Momentary	5	1	2 3	1 2

Minimum Rating: 25 microamperes at 5 millivolts or less.

SELECTION TABLE

CIRCUIT WITH LEVER IN . . .

	Up Position	Center Position	Down Position (Keyway)	Catalog Number ②
				
	FOUR POLE			
	ON	OFF	ON	8854K1
	ON	NONE	OFF	K7
	ON	NONE	ON	K4
	ON	OFF	NONE	K5
	ON *	OFF	ON *	K2
	NONE	OFF	ON *	K6
	ON	OFF	ON *	K3
	NONE	ON	ON *	K8 ①
	ON	ON	ON	K9 ①
	ON	ON	ON *	K10 ①
	ON *	ON	ON *	K11 ①



*** Momentary contact.**

① Dielectric per MILS-8834 except limited to 1250 Volts. Delayed action of the switch toggle lever may cause circuit to close or open before snap action mechanism trips.

② Caution should be exercised during soldering and flux removal. See page A56 for details.

MINIATURE POSITIVE ACTION SWITCHES

Series - 8854

4-Pole Miniature Positive Action Switch Series

MOUNTING DIMENSIONS - FOUR POLE / 8854

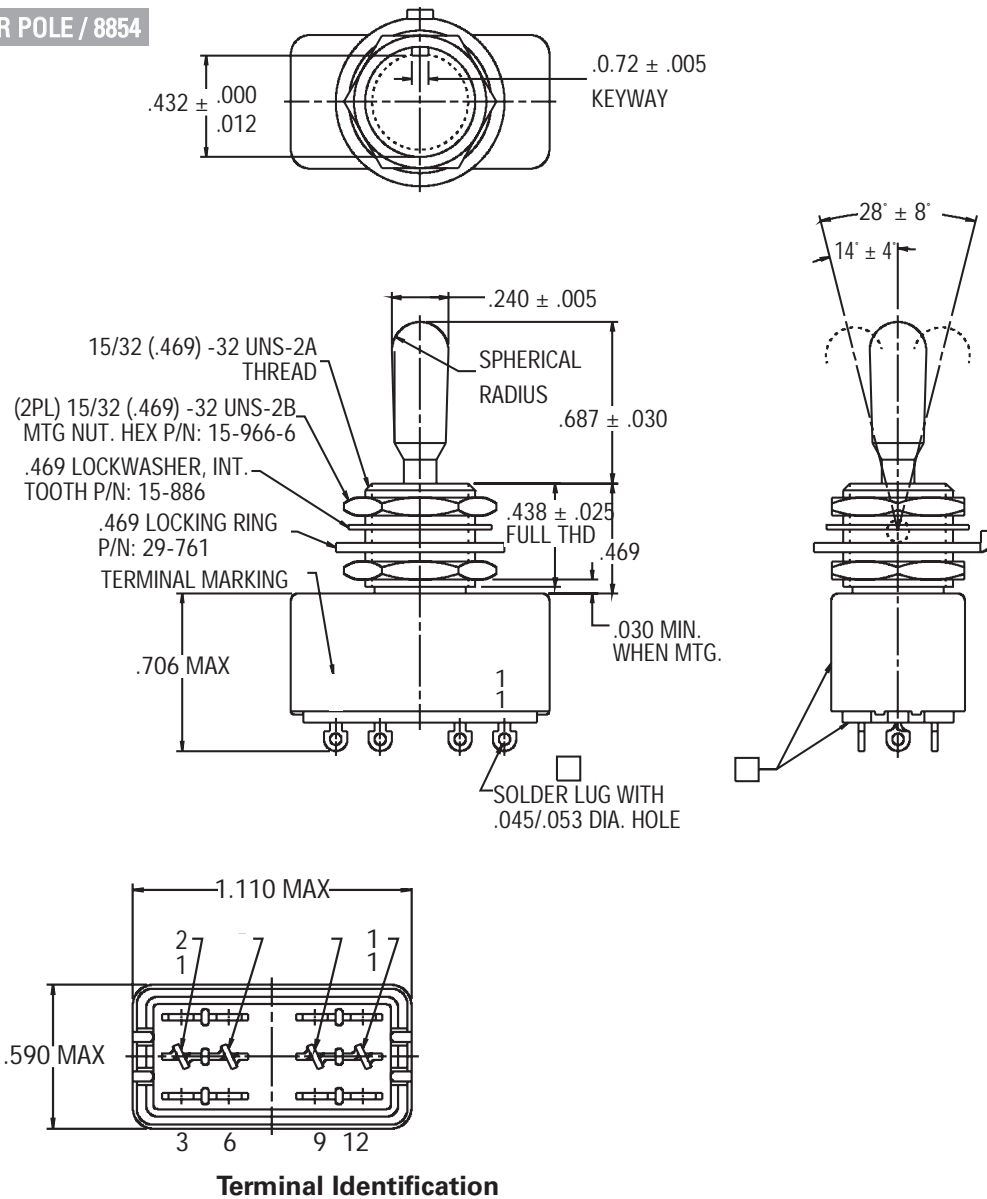

STANDARD
 0.00 = inches
 [0,0] = mm

Mounting dimensions for reference only.

Non-functional terminals not supplied.

FEATURES		SPECIFICATIONS	CURRENT RATINGS																							
<ul style="list-style-type: none"> Made to MIL-DTL-8834 Requirements Sealed bushing Current rating versatility 4 pole circuitry (Maintained & Momentary variations) Non-teasible mechanism for all but center "on" position Dry circuit (logic loads loads) to power switching levels Wiping action contacts Positive make and break action Bullet and Mushroom Lever lock Actuator styles 12 Lever Locking configurations 15/32" bushing Dia. Solder-lug terminals ± Ø 	<ul style="list-style-type: none"> Bushing seal per MIL-DTL-8834 Meets 0.5" Head of Water Temperature Range: -22°F to +149°F -30°C to +65°C Electrical Life: 20,000 Operations at rated load Mechanical Life: 40,000 Operations 	<table border="1" style="width: 100%; border-collapse: collapse;"> <thead> <tr> <th rowspan="2" style="text-align: center;">No. of Poles</th> <th rowspan="2" style="text-align: center;">Catalog Number</th> <th rowspan="2" style="text-align: center;">Type of Operation</th> <th colspan="2" style="text-align: center;">28 and 50VDC (Amperes per pole)</th> <th colspan="4" style="text-align: center;">115VAC 60Hz and 400Hz (Amperes per pole)</th> </tr> <tr> <th style="text-align: center;">Resistive Load 28VDC</th> <th style="text-align: center;">Inductive Load 28VDC</th> <th colspan="2" style="text-align: center;">Resistive Load 60Hz 400Hz</th> <th colspan="2" style="text-align: center;">Inductive Load 60Hz 400Hz</th> </tr> </thead> <tbody> <tr> <td style="text-align: center;">4</td> <td style="text-align: center;">8879</td> <td style="text-align: center;">Maintained and Momentary</td> <td style="text-align: center;">5</td> <td style="text-align: center;">1</td> <td style="text-align: center;">2</td> <td style="text-align: center;">3</td> <td style="text-align: center;">1</td> <td style="text-align: center;">2</td> </tr> </tbody> </table>	No. of Poles	Catalog Number	Type of Operation	28 and 50VDC (Amperes per pole)		115VAC 60Hz and 400Hz (Amperes per pole)				Resistive Load 28VDC	Inductive Load 28VDC	Resistive Load 60Hz 400Hz		Inductive Load 60Hz 400Hz		4	8879	Maintained and Momentary	5	1	2	3	1	2
						No. of Poles	Catalog Number	Type of Operation	28 and 50VDC (Amperes per pole)		115VAC 60Hz and 400Hz (Amperes per pole)															
Resistive Load 28VDC	Inductive Load 28VDC	Resistive Load 60Hz 400Hz		Inductive Load 60Hz 400Hz																						
4	8879	Maintained and Momentary	5	1	2	3	1	2																		
Minimum Rating: 25 microamperes at 5 millivolts or less.																										

SELECTION TABLE

CIRCUIT WITH LEVER IN . . . FOUR POLE



Up Position	Center Position	Down Position (Keyway)	Catalog® Number
ON	OFF	ON	8879K74
ON	OFF	ON	K75
ON	NONE	ON	K77
ON	NONE	ON	K78
ON	OFF	NONE	K79
ON	OFF	ON	K710
ON	OFF	ON *	K712
ON	NONE	OFF	K713
ON	NONE	OFF	K714
ON	OFF	ON *	K716
ON	OFF	NONE	K719
ON	OFF	ON *	K720
ON	ON	ON	K721 ①
ON *	ON	ON *	K722 ①
ON	ON	ON *	K723 ①
NONE	ON	ON *	K724 ①
ON *	OFF	ON *	K727
NONE	OFF	ON *	K728
ON *	OFF	ON *	K729
ON	ON	ON	K730 ①
ON	ON	ON	K731 ①
ON	ON	ON	K732 ①
ON *	ON	ON *	K734 ①
ON	ON	ON *	K735 ①
ON	ON	ON *	K736 ①

* **Momentary contact.**

① Dielectric per MILS-8834 except limited to 1250 Volts. Delayed action of the switch toggle lever may cause circuit to close or open before snap action mechanism trips.

② Caution should be exercised during soldering and flux removal. See page A56 for details.

MINIATURE POSITIVE ACTION SWITCHES

Series - 8879

4-Pole Miniature Positive Switch Series

MOUNTING DIMENSIONS - FOUR POLE / 8879

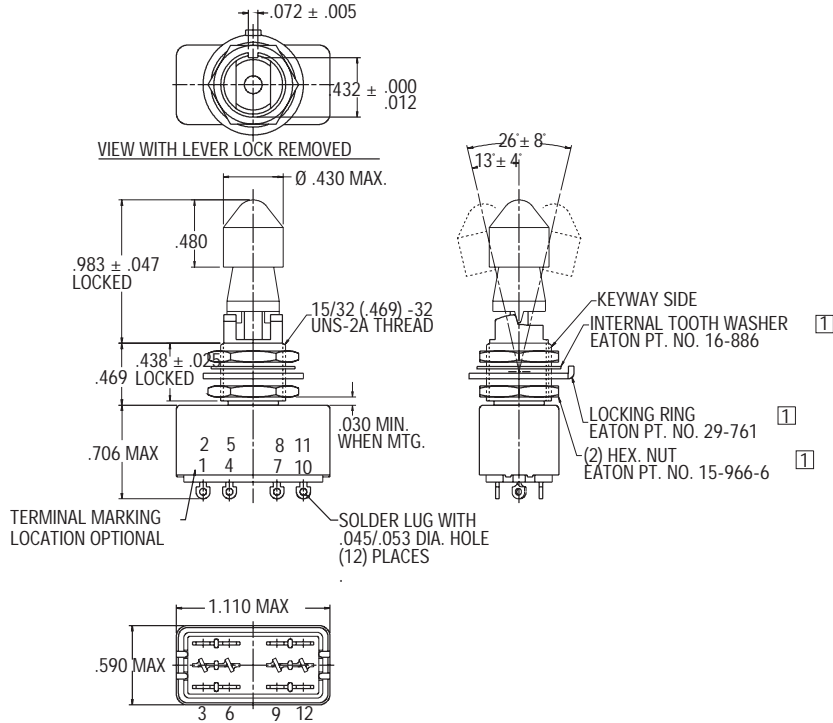

MOUNTING DIMENSIONS - FOUR POLE / 8879

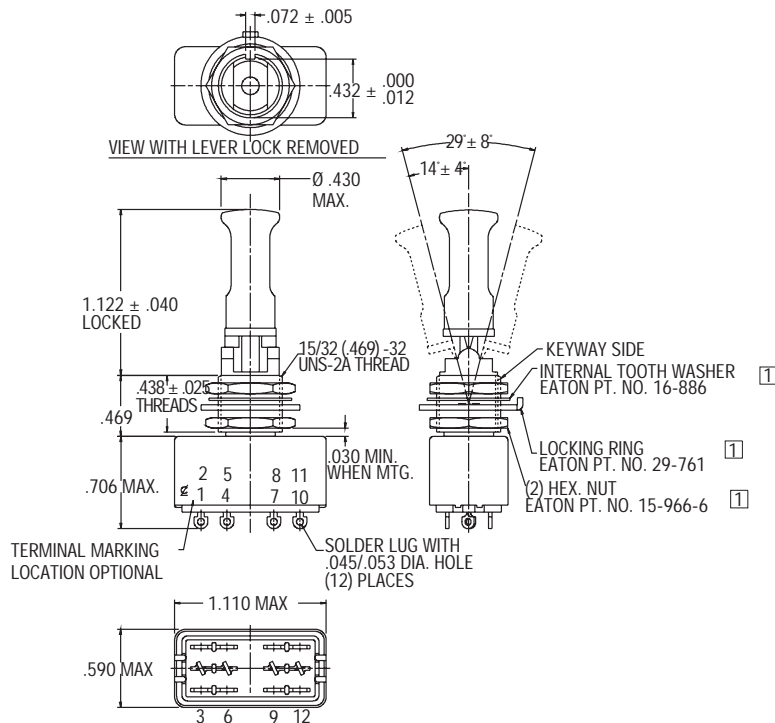

Terminal Identification

STANDARD

0.00 = inches

[0,0] = mm

Mounting dimensions for reference only.

Non-functional terminals not supplied.

Series T and TW

T 2150, TW 20,000, T 2660, TW 20,001

Series T

SPECIFICATIONS

- Seal: Dust resistant
- Type of Operation: Maintained
- Electrical Life: 10,000 operations at 28VDC or 115VAC
- Mechanical Life: 20,000 operations
- Operating Temp. Range: -85°F to +160°F (-65°C to +71°C)

CURRENT RATINGS

Catalog Number	Poles and Throw	28VDC			115 VAC		
		Lamp Load (Amps)	Resistive Load (Amps)	Inductive Load (Amps)	Lamp Load	Resistive Load (Amps)	Inductive Load (Amps) (.75)
T1002	1 P.S.T.	5	20	15	3	10	10
T1003	1 P.D.T.	5	20	15	3	10	10
T2106	1 P.D.T.*	—	10	5	—	10	5
T2114	1 P.D.T.*	—	10	5	—	10	5
T2150	2 P.D.T.	—	3	1	—	3	1
T2153	2 P.D.T.	—	3	1	—	3	1
T3103	1 P.D.T.	—	5	3	—	5	3
T3113	1 P.D.T.	—	5	3	—	5	3

*Two Circuit



T2114



T2153



T3113

Series TW (Sealed)

SPECIFICATIONS

- Seal: Dust proof (per MIL-S-83731)
- Type of Operation: Maintained
- Electrical Life: 20,000 operations at 28VDC or 115VAC
- Mechanical Life: 40,000 operations
- Operating Temp. Range: -40°F to +160°F (-40°C to +71°C)

CURRENT RATINGS

Catalog Number	MS Number ^①	Poles and Throw	28VDC			115 VAC		
			Lamp Load	Resistive Load	Inductive Load	Lamp Load	Resistive Load	Inductive Load (Amps)
TW1002	—	1 P.S.T.	5	20	15	3	10	10
TW1003	—	1 P.D.T.	5	20	15	3	10	10
TW20000	—	2 P.D.T.	.5*	2	.5*	.1	.1	.1
TW20001	—	1 P.D.T.*	.5	2	.5	.1	.1	.1
TW20002	MS18151-1	1 P.D.T.	.5	1	.5	.1	.1	.1

^① Qualified to MIL-S-83731

*Two Circuit



TW20000



TW20002



TW20001



TW1003

NOTE: For specific drawing dimensions, contact factory at 1-800-955-7354.

HIGH CAPACITY SWITCHES

Series - 8780-82, 8790 & 8792

High Capacity Flush Mounted Switches

FEATURES

- 1 and 3 pole circuitry
- Flush mounted (5 holes required)
- High capacity ratings
- Terminal stud termination

SPECIFICATIONS

- Military approved to MILS-3950C and E1663 specifications
- Current ratings up to 175 Amp on AN3230 type and 80 Amp on E1663 type
- Temperature Range: -67°F to +160°F (-55°C to +71°C)
- Life: 10,000 operations at rated load
20,000 operations mechanical life
- Power studs have .250" [6,35] -20 threads

CURRENT RATINGS

No. of Poles	Catalog Number	Type of Operation	28VDC			115 VAC 60 or 400Hz		
			Lamp Load	Resistive Load	Inductive Load	Lamp Load	Resistive Load	Inductive Load
1	8780K11	Maintained	35	175	45	11	55	45
	8781K11							
	8782K11							
3	8790K4	Maintained	12	80	30	7.5	30	20
	8792K3							

SELECTION TABLE



CIRCUIT WITH LEVER IN . . .



8780



8790

	Up Position 	Center Position 	Down Position (Keyway) 	MS or Government Drawing Number	AN Part Number	Catalog Number
One Pole - High Capacity						
	ON	OFF	ON	—	AN3230-1	8780K11
	ON	NONE	OFF	—	-2	8781K11
	ON	NONE	ON	—	-3	8782K11
Three Pole - High Capacity						
	ON	OFF	ON	E1663-1	—	8790K4
	ON	NONE	ON	-3	—	8792K3

MOUNTING DIMENSIONS - ONE POLE / 8780, 8781, 8782

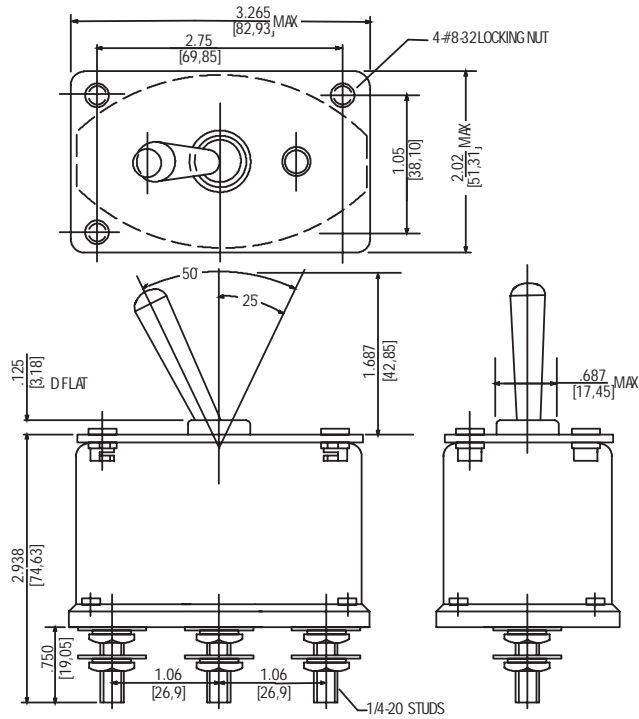

Terminal Identification

MOUNTING DIMENSIONS - THREE POLE / 8790, 8792

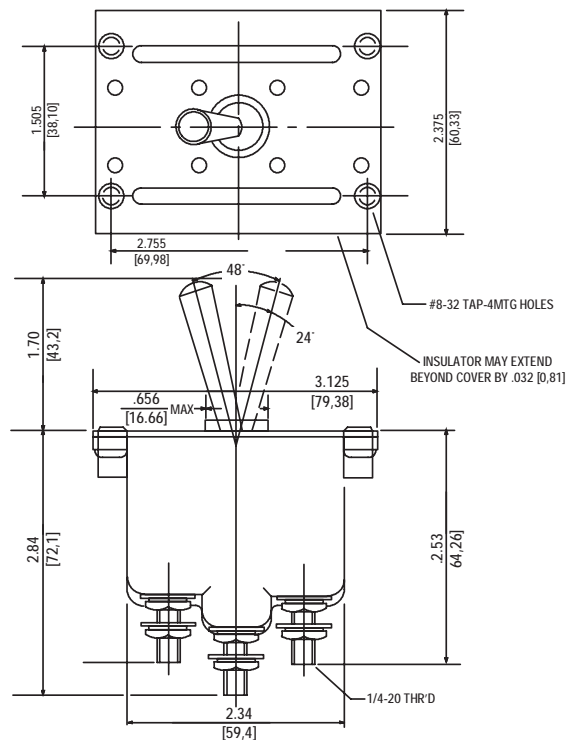

Terminal Identification

STANDARD
0.00 = inches
[0,0] = mm

Mounting dimensions for reference only.

Non-functional terminals not supplied.

NOMINAL RATINGS AND CIRCUIT DIAGRAMS

UL AND CSA NOMINAL RATINGS

Catalog Number	Amperes		Maximum Horsepower		
	125VAC	250VAC	1 Phase		3 Phase
			125VAC	250VAC	125/250VAC
8520K1, K4, K9	18	9	1/4	1/2	—
8521K1, K4, K9	18	9	1/2	1	—
8522K1, K4, K9	18	9	1/2	1	1
8526K2, K3, K5	18	9	—	—	—
8527K2, K3, K5	18	9	—	—	—
8528K2, K3, K5	18	9	—	—	—
8530K1-13, K31-313, K91-913	18	9	1/4	1/2	—
8531K1-16, K31-316, K91-916	18	9	1/2	1	—
8532K1-17, K31-317, K91-917	18	9	1/2	1	1
8533K1-13, K31-313, K91-913	18	9	1/4	1/2	—
8534K1-13, K31-316, K91-916	18	9	1/2	1	—
8535K1-17, K31-317, K91-917	18	9	1/2	1	1
8536K1-13, K31-313, K91-913	18	9	1/4	1/2	—
8537K1-16, K31-316, K91-916	18	9	1/2	1	—
8538K1-17, K31-317, K91-917	18	9	1/2	1	1

BASIC SWITCH CIRCUITS

BACK CONFIGURATIONS

SCHEMATIC DIAGRAMS

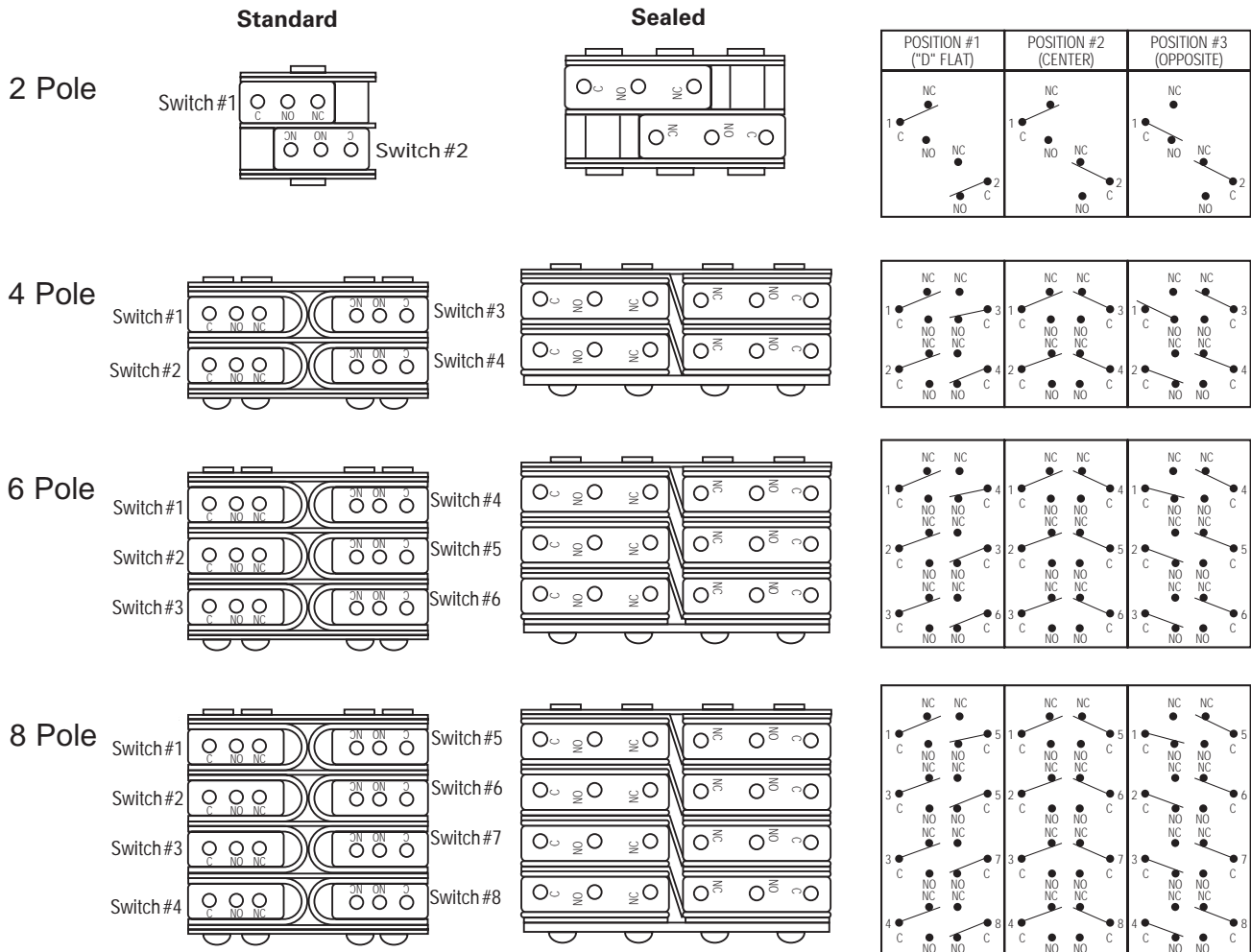



TOGGLE SWITCHES - ENVIRONMENTALLY SEALED SWITCHES

Standard Circuit Arrangements

Industrial, Econoswitch and MIL-S-3950 Series

CIRCUIT WITH LEVER IN . . .

Number of Poles and Throws	Switch Circuit ^①	Up Position 	Center Position 	Down Position (Keyway) 
1PST	ON-NONE-OFF		NONE	OFF
	ON-OFF-NONE		OFF	NONE
	ON-OFF*-NONE		OFF(MOM.)	NONE
	NONE-OFF-ON*		OFF	OFF(MOM.)
	ON-NONE-OFF*		NONE	OFF(MOM.)
	OFF-NONE-ON*		OFF	NONE
1PDT	ON-OFF-ON		NONE	OFF
	ON-NONE-ON		NONE	OFF
	ON-NONE-ON*		NONE	OFF
	ON-OFF-ON		OFF	OFF
	ON-OFF-ON*		OFF	OFF
	*ON-ON-NONE		NONE	NONE
	ON-ON-NONE		NONE	NONE
2PST	ON-NONE-OFF		NONE	OFF
	ON-OFF-NONE		OFF	NONE
	ON-OFF*-NONE		OFF(MOM.)	NONE
	NONE-OFF-ON*		OFF	OFF(MOM.)
	ON-NONE-OFF*		NONE	OFF(MOM.)
	OFF-NONE-ON*		OFF	NONE
2PDT	ON-OFF-ON		NONE	OFF
	ON-NONE-ON		NONE	OFF
	ON-NONE-ON*		NONE	OFF
	ON-OFF-ON		OFF	OFF
	ON-OFF-ON*		OFF	OFF
	*ON-ON-NONE		NONE	NONE
	ON-ON-NONE		NONE	NONE
4PST	ON-NONE-OFF		NONE	OFF
	ON-OFF-NONE		OFF	NONE
	ON-OFF*-NONE		OFF(MOM.)	NONE
	NONE-OFF-ON*		OFF	OFF(MOM.)
	ON-NONE-OFF*		NONE	OFF(MOM.)
	OFF-NONE-ON*		OFF	NONE















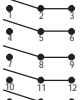

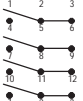
* Momentary Contact

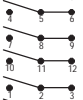
TOGGLE SWITCHES - ENVIRONMENTALLY SEALED SWITCHES

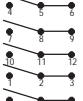
Standard Circuit Arrangements

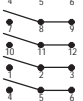
Industrial, Econoswitch and MIL-S-3950 Series

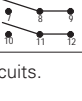
CIRCUIT WITH LEVER IN . . .

Number of Poles and Throws	Switch Circuit ^①	Up Position 	Center Position 	Down Position (Keyway) 
4PDT	ON-OFF-ON		OFF	
	ON-NONE-ON		NONE	
	ON-NONE-ON*		NONE	
	ON-OFF-ON		OFF	
	ON-OFF-ON*		OFF	
	*ON-ON-NONE			NONE
	ON-ON-NONE			NONE

^① See page A75 for ON-ON-ON and special circuits.











































































* Momentary contact.

TOGGLE SWITCHES - ENVIRONMENTALLY SEALED SWITCHES

Special ON-ON-ON Circuit Arrangements for Two and Four Pole Switches

Industrial, Econoswitch and MIL-S-3950 Series

Circuit with Lever in . . .

Number of Poles	Up Position 	Center Position 	Down Position (Keyway) 	Catalog Part Number
TWO POLE				
2	Maintained  	Maintained  	Maintained  	8501K14, 8504K43-K55, 8511K14 8531K14, 8531K914, 8531K314 8534K14, 8534K914, 8534K314 8537K14, 8537K914, 8537K314, 8567K14
2	Maintained  	Maintained  	Momentary  	8501K15, 8504K56-K61, 8511K15 8531K15, 8531K915, 8531K315 8534K15, 8534K915, 8534K315 8537K15, 8537K915, 8537K315, 8567K15
2	Momentary  	Maintained  	Momentary  	8501K16, 8504K62-K64, 8511K16 8531K16, 8531K916, 8531K316 8534K16, 8534K916, 8534K316 8537K16, 8537K916, 8537K316, 8567K16
2	Maintained  	Maintained  	Maintained  	8501K17, 8504K65-K77, 8511K17 8531K17, 8531K917, 8531K317 8567K17, 8571K17-16, 8571K17-20 8574K65-16 - 8574K77-16 8574K65-20 - 8574K77-20
2	Maintained  	Maintained  	Momentary  	8501K18, 8504K78-K83, 8511K18 8531K18, 8531K918, 8531K318 8567K18, 8571K18-16, 8571K18-20 8574K78-16 - 8574K83-16 8574K78-20 - 8574K83-20
2	Momentary  	Maintained  	Momentary  	8501K19, 8504K84-K87, 8511K19 8531K19, 8531K919, 8531K319 8567K19, 8571K19-16, 8571K19-20 8574K84-16, 8574K86-16 8574K84-20, 8574K86-20
FOUR POLE				
4	Maintained    	Maintained    	Maintained    	8502K15, 8512K15 8532K15, 8532K915, 8532K315 8535K15, 8535K915, 8535K315 8538K15, 8538K915, 8538K315 8568K15 8575K43-16 - 8575K55-16 8575K43-20 - 8575K55-20
4	Maintained    	Maintained    	Momentary    	8502K16, 8512K16 8532K16, 8532K916, 8532K316 8535K16, 8535K916, 8535K316 8538K16, 8538K916, 8538K316 8568K16 8575K56-16 - 8575K61-16 8575K56-20 - 8575K61-20
4	Momentary    	Maintained    	Momentary    	8502K17, 8512K17 8532K17, 8532K917, 8532K317 8535K17, 8535K917, 8535K317 8538K17, 8538K917, 8538K317 8568K17 8575K62-16 - 8575K64-16 8575K62-20 - 8575K64-20

TOGGLE SWITCHES - ENVIRONMENTALLY SEALED SWITCHES

Special Circuit Arrangements for Two and Four Pole Switches

Industrial, Econoswitch and MIL-S-3950 Series

SPECIAL "ON-ON-ON" CIRCUIT ARRANGEMENTS

"Three Independent" ON-ON-ON Circuit Diagram

For switch modified with "Three Independent" ON-ON-ON Special Circuit.

External Jumpers are required. User to connect wiring per instructions given below.

Connection Points	Single Pole ^①	Double Pole ^②
Connect Common to Terminals	2	2 and 11
Connect Circuit "A" to Terminals	6	6 and 9
Connect Circuit "B" to Terminals	4	4 and 7
Connect Circuit "C" to Terminals	1	1 and 10

Circuit Poles	No. of Poles	Up Position	Center Maintained Position	Down Position (Keyway)
Circuit for Single Pole (Jumper between Terminals #3 & #5)	1			
Circuit for Double Pole (Jumpers between Terminals #3 & #5 #8 & #12)	2			

^① Requires using a two pole switch to accomplish single pole independent "on-on-on" circuit.

^② Requires using a four pole switch to accomplish a double pole independent "on-on-on" circuit.

Note: Basic circuit same as offered with part numbers 8501K14, 8501K15 or 8501K16 for two pole devices and part numbers 8502K15, 8502K16 or 8502K17 for four pole devices.

SPECIAL CIRCUIT (OFF-ON-ON)

Circuit	No. of Poles	OFF Up Position	ON Center Maintained Position	ON Down Position (Keyway)	Circuit Being Made . . .	Terminal Numbers Making the Circuit
Note: Requires two poles to achieve a single pole device or four poles to achieve a double pole device.						
Circuit for Single Pole (Jumper between terminals #2 & #4). Common terminal #5. Non-functional terminal #6	2	(OFF) 	(ON) 	(ON) 	UP (OFF) CENTER (ON) DOWN (ON)	— #3 & #5 #1 & #5
Circuit for Double Pole (Jumpers between terminals #2 & #4 and #7 & #11). Common terminals #5 & #8. Non-functional terminals #6	4	(OFF) 	(ON) 	(ON) 	UP (OFF) CENTER (ON) DOWN (ON)	— #3 & #5 #8 & #12 #1 & #5 #8 & #10

SPECIAL PROJECTOR CIRCUIT (OFF-ON-ON)

Circuit	No. of Poles	OFF Up Position	ON Center Maintained Position	ON Down Position (Keyway)	Circuit Being Made . . .	Terminal Numbers Making the Circuit
Note: Requires two poles to achieve a single pole device or four poles to achieve a double pole device.						
Circuit for Single Pole (Jumper between terminals #2 & #5). Common terminal #5. Non-functional terminal #1 & #4.	2	(ON) 	(ON) 	(OFF) 	UP (ON) CENTER (ON) DOWN (OFF)	#2 & #3 #5 & #6 #5 & #3
Circuit for Double Pole (Jumpers between terminals #2 & #5 and #8 & #11). Common terminals #5 & #8. Non-functional terminals #1, #7 & #9.	4	(ON) 	(ON) 	(OFF) 	UP (ON) CENTER (ON) DOWN (OFF)	#5 & #3 #5 & #6 #8 & #12 #8 & #9 #3 & #5 #8 & #12

SPECIAL ON-ON-ON CIRCUITS FOR Miniature POSITIVE ACTION SWITCHES

Circuit Arrangements

CIRCUIT WITH LEVER IN . . .

Number of Poles	Up Position 	Center Position 	Down Position (Keyway) 	Catalog Part Number
Two Pole				
2	Maintained 	Maintained 	Maintained 	8856K21, K30, K31, K32 8856K21X, K30X, K31X, K32X 8856K721, K730, K731, K732 8867K9, 8867K69, 8867KA69 8869K9, 8869K9X, 8869K69, 8869K69X
2	Maintained 	Maintained 	Momentary 	8856K23, K35, K36 8856K23X, K35X, K36X 8856K723, K735, K736 8867K10, 8867K610, 8867KA610 8869K10, 8869K10X, 8869K610, 8869K610X
2	Maintained 	Maintained 	Momentary 	8856K22, K34 8856K22X, K34X 8856K722, K734 8867K11, 8867K611, 8867KA611 8869K11, 8869K11X, 8869K611, 8869K611X

SPECIAL "ON-ON-ON" CIRCUIT ARRANGEMENTS

"Three Independent " ON-ON-ON Circuit Diagram
 For switch modified with "Three Independent" ON-ON-ON Special Circuit.
 External Jumpers are required. User to connect wiring per instructions given below.

Connection Points	Single Pole [Ⓞ]
Connect Common to Terminals	2
Connect Circuit "A" to Terminals	6
Connect Circuit "B" to Terminals	4
Connect Circuit "C" to Terminals	1

Circuit Poles	No. of Poles	Up Position 	Center Maintained Position 	Down Position (Keyway)
Circuit for Single Pole (Jumper between Terminals #3 & #5)	1			

ⓄRequires using a two pole switch to accomplish single pole Independent "ON-ON-ON" circuit.

Pushbutton Switches Index

Index

B-1

**Standard Pushbutton Switches**

B2 - B14

- Momentary and alternate action
- Ratings up to 40 amperes
- One and two pole configurations
- Single hole mounting
- Decorative Actuator in various colors
- Two moisture proof series

**Uniform Panel Appearance (UPA) Pushbutton Switches**

B15 - B17

- Ratings up to 10 amperes
- One, two and four pole configurations
- Solder lug or quick connect terminals
- Momentary snap or push-pull action
- Single hole mounting
- RFI version available

**Sub-Miniature Pushbutton Switches**

B18 - B19

- Snap action
- MIL approved
- Sealed or non-sealed
- Low operating force

**Illuminated Switches**

B20

- Momentary or alternate action
- Ratings up to 2 amperes
- Two pole and two circuit configurations
- Single hole mounting
- Most designed to use MS25237 type lamps

**Hand Controls with Pushbutton Switches**

B21 - B23

- Control stick mounting
- Non "freeze" durable phenolic handle
- Heavy duty trigger switch
- Available with cord for remote operation
- Available with auxiliary switch

**Special Designed Pushbutton Switches**

B24 - B25

- Foot operated microphone switches
- Mechanically actuated switches with lock feature
- Switching mechanism sealed against dust and moisture
- Rugged construction with flush mounting design

**Most items listed in this catalog are standard products and are normally in Distributor Inventory; however, the current inventory status should be checked by contacting your Eaton Customer Service Representative at 800-955-7354 or your authorized Distributor before placing orders.*

PUSHBUTTON SWITCHES

Series - D200 Heavy Duty

Momentary Snap Action Pushbutton Switches

FEATURES SPECIFICATIONS CURRENT RATINGS

- High current carrying capability
- Heavy duty pushbutton
- Snap action mechanism
- Minimal arcing and contact wear
- Fast double break action
- Variety of case styles and colors
- Protective shields can be ordered separately to prevent accidental actuation on "W" case model
- Black pushbutton supplied as standard

- Operating force: 2.5 lbs ± .5 lb (11N ± 2.2N)
D201 thru D205
4 lbs. ± 1 lb. (17.79N ± 4.45N)
D207
- Electrical life: 25,000 operations
minimum at rated load
- Total plunger travel (Approx.):
0.085 IN. (2.16mm),
0.438 IN. (11.12mm)
with "L" Adapter
- Operating temperature: -40°F to +160°F
(-40°C to +71°C)
- Momentary snap action
- Terminals: End Screw (Center Terminal Solder)
- Weight: "W" case 0.040 lb. (18g)
"P" case 0.050 lb (23g)
"L" case 0.045/0.055 lb (20g/25g)

Part Number	Number of Poles	Operation	28VDC		115VAC	
			Resistive Load	Inductive Load ^①	Resistive Load	Inductive Load ^①
D201	1	Momentary	35	20	35	20
D202	1	Momentary	35	20	35	20
D203	1	Momentary	35	20	35	20
D204	1	Momentary	15	—	15	—
D205	1	Momentary	15	—	15	—
D207	1	Momentary	10 ^②	—	10 ^②	—

^① p.f. = .75

^② 3 amps max. through center terminal.

WHEN ORDERING SPECIFY...

- **Catalog number of base switch** - followed by suffix letters and numbers for type and color of case and pushbutton

Order Example:

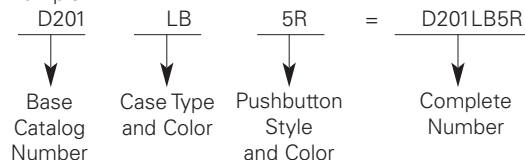

SELECTION TABLE

SERIES AND TYPE

D200 Series



Base Catalog Number	Circuit	Case and Type and Color	Code Suffix	Pushbutton Style and Color		Code Suffix
				Button Style	Color	
D201	1 P.S.T.-NO Dbl. Brk.	Type "L"			Chrome	5
D202	1 P.S.T.-NC Dbl. Brk.	Black	LB		Black	5B
D203	1 P.D.T.-2 Ckt	Clear	L			
D204	S.P.-NO 3 Terminal	Type "P"			Red	2R
D205	S.P.-NC 3 Terminal	Black Clear	PB P		White Black	2W 2
					Red	3R
					White	3W
					Black	3
D207	S.P.-NO 4 Terminal	Type "W"			Red	2R
		Black Clear	WB W		White Black	2W 2
					Red	3R
					White Black	3W 3

D201L5 With Type "L" Case



D201P3 With Type "P" Case



D201W3 With Type "W" Case

Series - D200 Heavy Duty

Momentary Snap Action Pushbutton Switches

APPROXIMATE DIMENSIONS - D200 "L" CASE

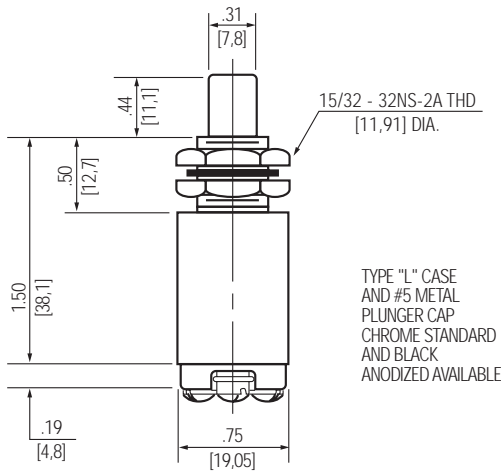

APPROXIMATE DIMENSIONS - D200 "P" CASE

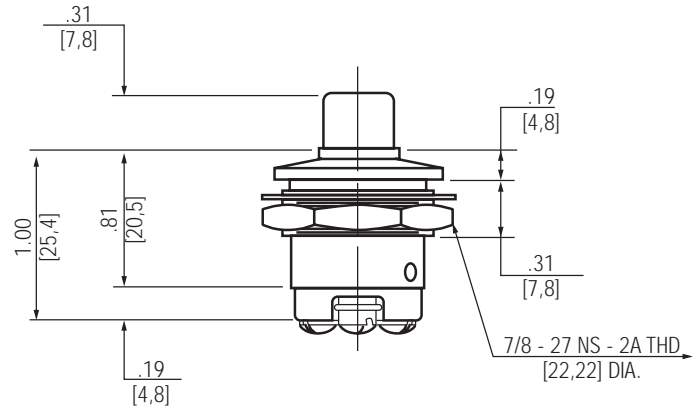

APPROXIMATE DIMENSIONS - D200 "W" CASE

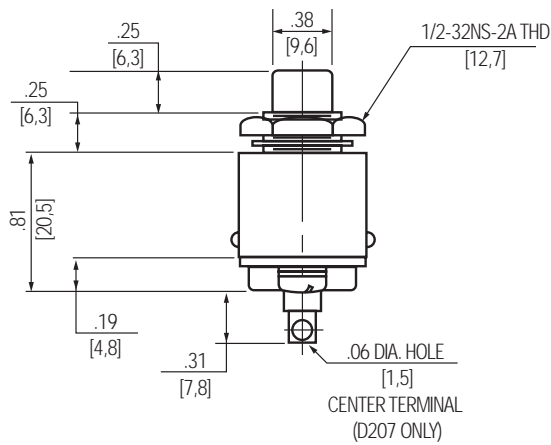

BASIC SWITCH AND SCHEMATIC DIAGRAM

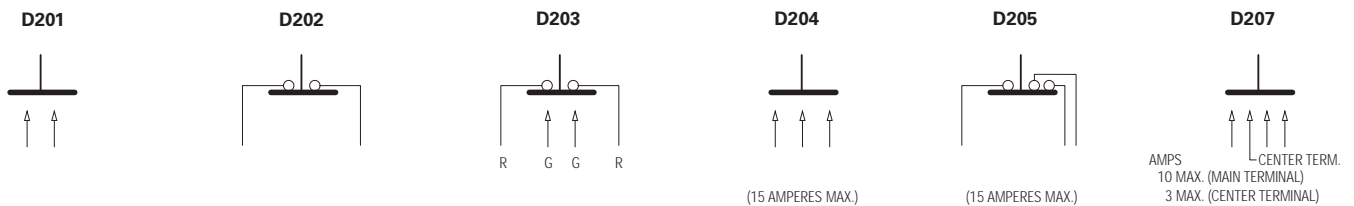

STANDARD
0.00 = inches
[0,0] = mm

Dimensions for reference only.

PUSHBUTTON SWITCHES

Series - H2200 Double Pole

Momentary Snap Action Pushbutton Switches

FEATURES

- Double pole
- Optional mounting adapters
- Various styles and colors of pushbuttons
- Solder terminals
- Momentary snap action
- Protective shields can be ordered separately to prevent accidental actuation on "W" case model
- Black pushbutton supplied as standard
- Other colors available

SPECIFICATIONS

- Operating force: 5.5 ± 1.5 lbs (24.2N ± 6.6N)
- Release force: 1 lb. minimum (.45g)
- Electrical life: 25,000 operations minimum at rated load
- Terminals: Solder
- Weight approx.: .05 lb. (.023g)



CURRENT RATINGS

Catalog Number	Number of Poles	Type of Operation	28VDC Inductive	125VAC Inductive ^⓪
H2211	2	Momentary	10	10
H2222	2	Momentary	10	10
H2266	2	Momentary	35	20

^⓪ p.f. = .75

SELECTION TABLE

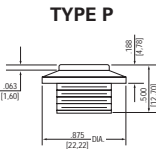
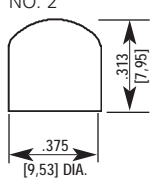
SERIES AND TYPE

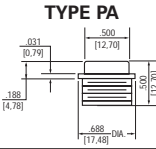
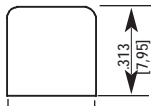
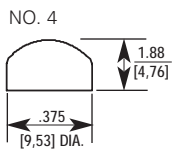
Part Number	Circuit	Adapter Type ^① and Color ^③			Pushbutton Type and Color			
		Type	Color	Code Suffix	Type ^②	Color	Code Suffix	
 H2211PB3 With Type "P" Adapter	2 P.S.T.-NO Double Break	 TYPE P	Black	PB	 NO. 2	Red	2R	
	2 P.S.T.-NC Double Break		Clear	P		Black	2	
 H2266 Without Mounting Adapter	2 P.D.T. Double Break	 TYPE PA	Black	PAB	 NO. 3	Red	3R	
			Clear	PA		Black	3	
			Black	UB		 NO. 4	Red	4R
			Clear	U			Black	4

① Clear anodized aluminum is standard. All threads are 1/2"-32 NS-2B internal; 5/8"-24 NEF-2A external except as noted.

② The different pushbutton types are only available when using with one of the 4 different adapters.

③ When used with any of these adapters the switch can be used as part of the UPA group of switches on pages B16 and B17.

WHEN ORDERING SPECIFY...

- For switch with pushbutton only - specify catalog number of base switch followed by code for pushbutton color. Use code R for red and leave blank if black button is desired. Examples:

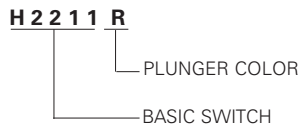

- For switch with mounting adapter - specify catalog number of base switch followed by suffix letters and numbers for type and color of adapter and pushbutton. Example:

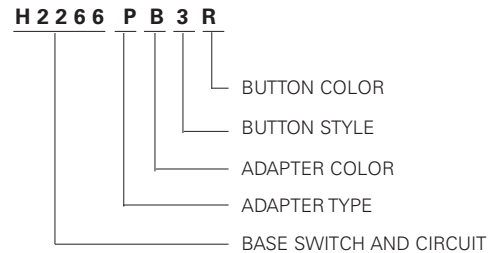

APPROXIMATE DIMENSIONS - H2200

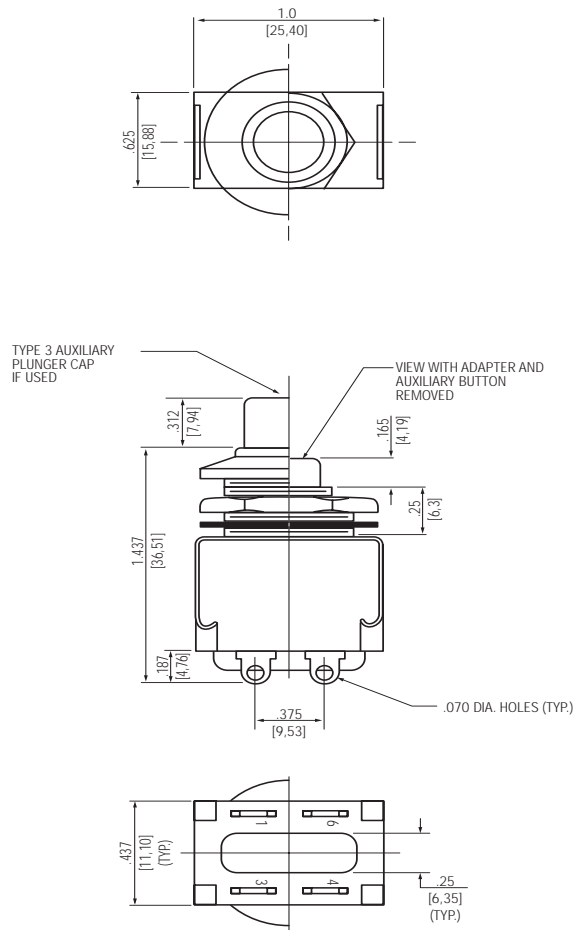

BASIC SWITCH AND SCHEMATIC DIAGRAM

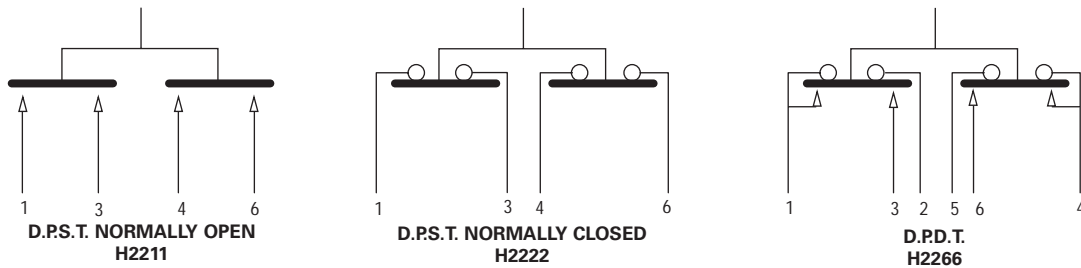

STANDARD
 0.00 = inches
 [0,0] = mm

Dimensions for reference only.

PUSHBUTTON SWITCHES

Series - J300

Alternate Action Moisture Proof Pushbutton Switches

FEATURES

- Alternate action push-push
- Moisture proof
- Snap action contact design
- Seven adapter styles
- Four button colors
- EMI/RFI version (J334)

SPECIFICATIONS

- DPDT (J333, J334) and two circuit (J313)
- EMI/RFI shielded (J334P6)
- Seal level 2 per MIL-S-8805
- Operating force: 2.75 ± 1 lb (12 IN. \pm 4.4N)
- Electrical life: 25,000 operations minimum
- Operating temperature: -40°F to +185°F (-40°C to +85°C)
- Total plunger travel: 0.200 in. (5.1mm) approx.
- Weight (approx.): 0.035 lbs (15.9g)
- Available in number 6 button style only

CURRENT RATINGS

Part Number	Number of Poles	Type of Operation	28VDC			120VAC		
			Resistive Load	Inductive Load	Lamp Load	Resistive Load	Inductive Load ^①	Lamp Load
J313	1	Alternate	10	5	1	10	5	1
J333	2	Alternate	1	—	1	1	—	1
J334 ^②	2	Alternate	1	—	—	1	—	—

^① p.f. = .75

^② EMI/RFI shielded

ORDERING INFORMATION

J 3 1 3 W 6

- BUTTON STYLE
- CLEAR "W" ADAPTER
- 2 CIR. SWITCH TYPE

J 3 3 3 P B 6 R

- RED BUTTON
- BUTTON STYLE
- BLACK "P" ADAPTER
- DPDT SWITCH TYPE

J 3 3 4 P 6 R

- RED BUTTON
- DPDT EMI/RFI SHIELDED SWITCH

SPECIFY ADAPTER

- Seven Adapter Styles
Specify Black: B, Clear: No letter
- Plunger Color, Specify:
Black: No letter
Red: R
White: W
Gray: GY
- DPDT J333 and Two Circuit J313
- J334 only available as J334P6 or J334P6R

ADAPTER STYLES

TYPE HA

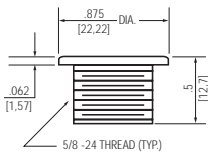

TYPE M

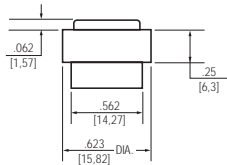

TYPE N

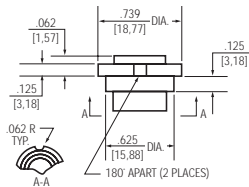

TYPE P

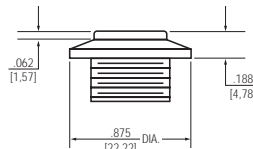

TYPE PA

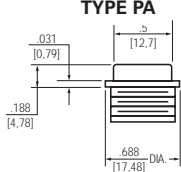

TYPE W

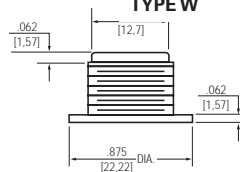

TYPE Y

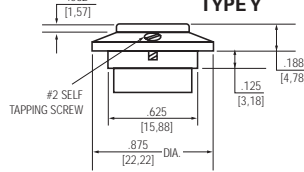

STANDARD

0.00 = inches

[0,0] = mm

Dimensions for reference only.

DIMENSIONS - J300

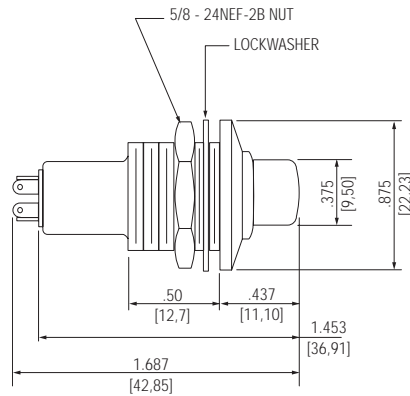

SCHEMATIC DIAGRAMS

J313 TYPE

J333 AND J334 TYPE

TWO CIRCUIT

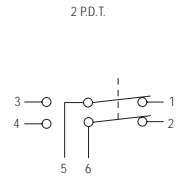
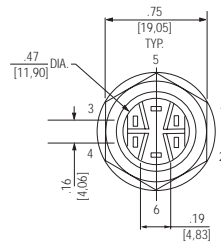
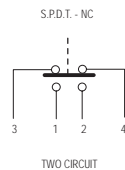
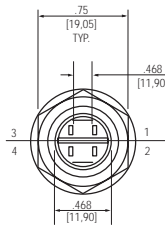

"W" J334P6 - EMI/RFI SHIELDING

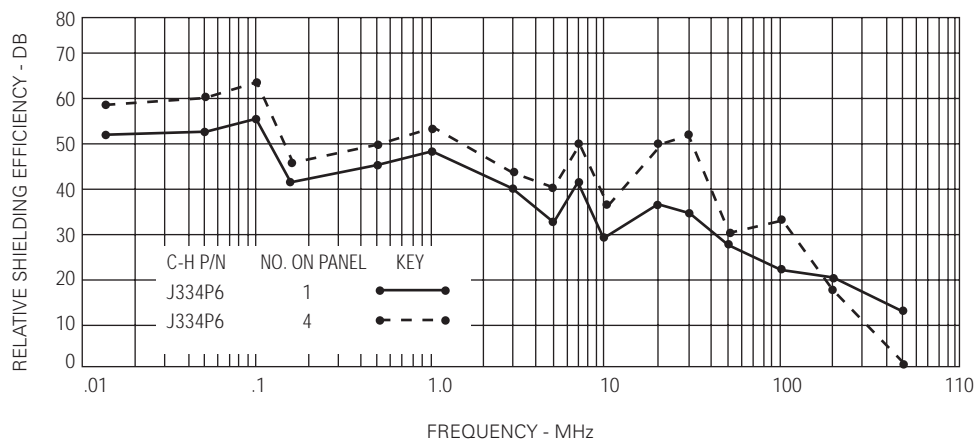

Graphic illustration defines relative shielding efficiency of RFI shielded component/ components over unshielded device.

STANDARD

0.00 = inches

[0,0] = mm

Mounting dimensions for reference only.

PUSHBUTTON SWITCHES

Series - C20050

Momentary Snap Action Pushbutton Switches

FEATURES SPECIFICATIONS CURRENT RATINGS

- Snap action pushbutton
- Compact size
- Black or red buttons available
- Momentary

- Meets MIL-S-8805/20
- Operating force: 3.5 ± 1 lb (2.48kg ± .68kg)
- Electrical life: 40,000 operations minimum at rated load
- Mechanical life: 50,000 operations minimum
- Terminal strength: 5 lbs (2.25kg)
- Single pole, two circuit
- Weight approx.: .02 lb (9g)

Part Number	Number of Poles	Type of Operation	120VAC ^①	120VDC	230VDC ^②
C20050	1	Momentary	15	1	0.05

^① p.f. = .50

^② 5,000 operations

SELECTION TABLE



Circuit	Operation	Case Color	Button Color	Catalog Number	Military Part Number
1 PD.T-2 Ckt.	Momentary	Clear	Black	C20050	MS16712-1
1 PD.T-2 Ckt.	Momentary	Clear	Red	C20050R	MS16712-2

C20050

APPROXIMATE DIMENSIONS - C20050

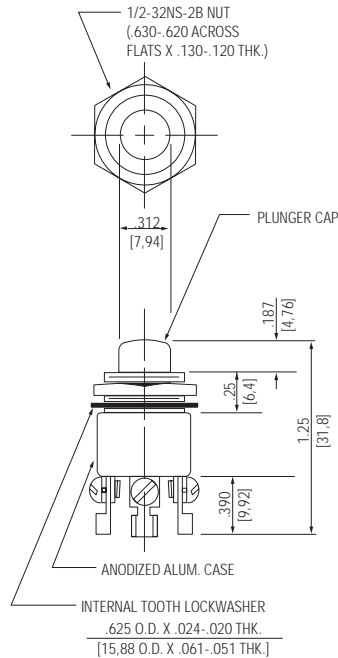

BASIC SWITCH SCHEMATIC DIAGRAM

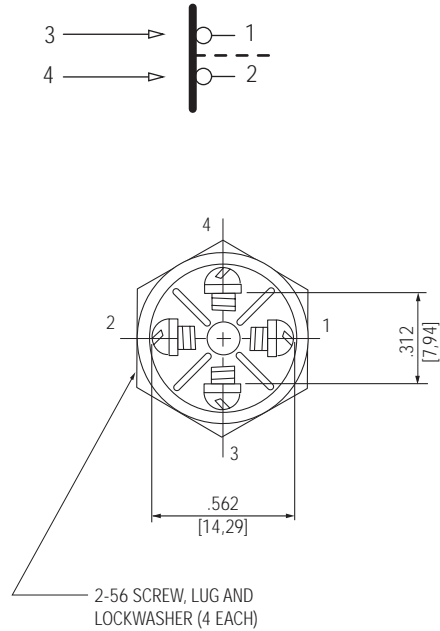

Mounting and terminal hardware supplied unassembled.

STANDARD

0.00 = inches

[0,0] = mm

Dimensions for reference only.

FEATURES	SPECIFICATIONS	CURRENT RATINGS			
		28VDC		125VAC	
		Resistive Load	Inductive Load	Resistive Load	Inductive Load ^①
<ul style="list-style-type: none"> Alternate action Snap action mechanism Single piece case construction Two case and four button colors available 	<ul style="list-style-type: none"> Single pole, double throw, two circuit Operating force: 2 ± 0.75 lb (8.8N ± 3.3N) Mechanical life: 50,000 operations minimum Total plunger travel: 0.172in. (4.37mm) approx. Weight (approx.): 0.32 lbs (15g) Solder lug terminals 	Part Number J4004 ^① p.f.=.75	Number of Poles 1	Type of Operation Alternate	10 5 10 5

WHEN ORDERING SPECIFY...

• **Catalog number of base switch** - followed by suffix letters for color of case and pushbutton

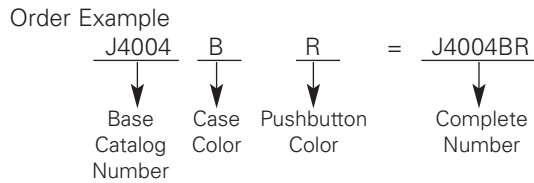

SELECTION TABLE

 J4004 Series	Base Catalog Number	Circuit	Case Color		Case Color	
			Color	Code Suffix	Color	Code Suffix
	J4004	1 P.D.T.-2 Ckt.	Black	B	Gray	GY
		Clear	None	White	W	
				Red	R	
				Black	None	

APPROXIMATE DIMENSIONS

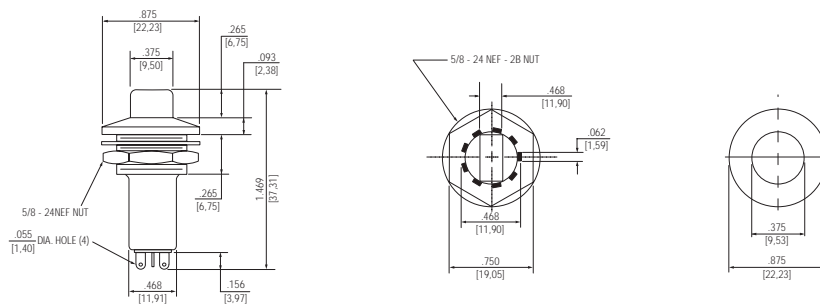

SCHEMATIC DIAGRAM

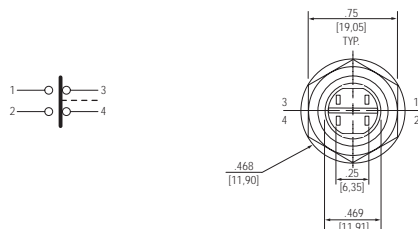

STANDARD
 0.00 = inches
 [0,0] = mm

Dimensions for reference only.

PUSHBUTTON SWITCHES

Series - J100 Alternate Action

High Current Pushbutton Switches

FEATURES

- Alternate action
- Snap action mechanism
- Single piece case construction
- Compact cylindrical size
- Black button standard
- Other colors available

SPECIFICATIONS

- Rated up to 40 amps DC or AC
- Operating force: 4 ± 2 lbs (1.8kg \pm 0.9kg)
- Total plunger travel: 0.25 in.(0.635mm) approx.
- Weight (approx.): 1 oz. approx. (28.3g)

CURRENT RATINGS

Part Number	Number of Poles	Type of Operation	28VDC				115VAC			
			Continuous	Resistive	Inductive	Lamp	Continuous	Resistive	Inductive	Lamp
J100	1	Alternate	40	20	15	5	40	10	10	3
J103	1	Alternate	40	20	15	5	40	10	10	3

SELECTION TABLE



J100

Series and Type	Circuit	Catalog Number
J100	1 P.S.T.-NO.	J100
J103	1 P.D.T.-ON-ON	J103

APPROXIMATE DIMENSIONS - J100 AND J103

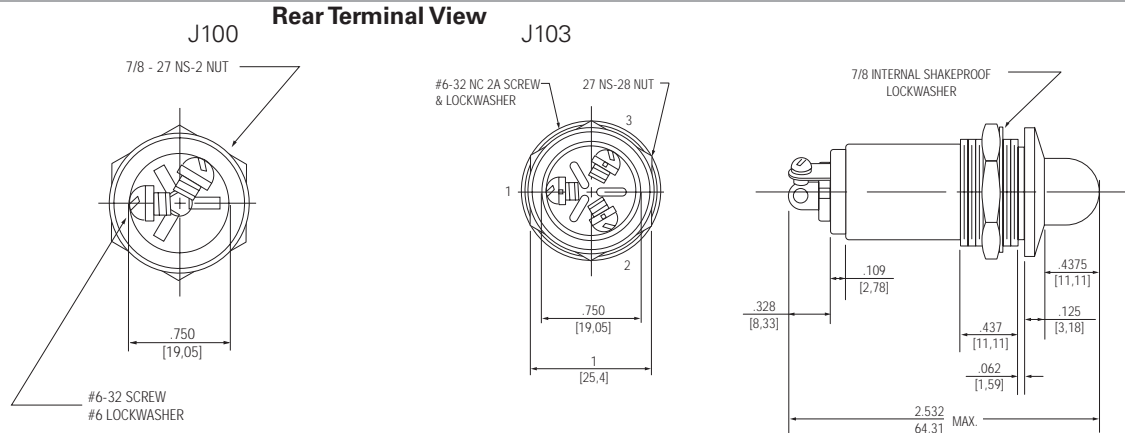

- J103 has three terminals

SCHEMATIC DIAGRAMS

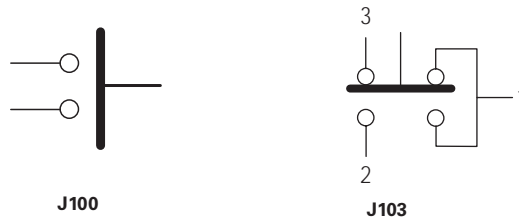

STANDARD

0.00 = inches

[0,0] = mm

Dimensions for reference only.

Mounting and terminal hardware supplied unassembled.

FEATURES	SPECIFICATIONS	CURRENT RATINGS							
		28VDC			125VAC ^①				
<ul style="list-style-type: none"> Moisture-proof Momentary snap action Black plunger (as standard) Various color adapters available 	<ul style="list-style-type: none"> Electrical life: 25,000 operations minimum at rated current Temperature range:-67°F to +185°F (-55°C to +85°C) Exceeds MIL-S-8805 Seal Level 2 Operating force: 5 ± 1 lb (22N ± 4.4N) Total plunger travel: 0.085 in. (0.22mm) approx. Weight with adapter: 0.025 lbs approx. 	Part Number	Type of Operation	Resistive	Inductive	Lamp	Resistive	Inductive	
				W300	1	Momentary	10	5	3

^① .75 PF

SELECTION TABLE

Series and Type	Operation	Circuit Catalog Schematic	Catalog Number
W300	Momentary Snap Action	1 P.S.T.-NO 	W301
		1 P.S.T.-NC 	W302
		1 P-2 Circuit 	W303



W300

WHEN ORDERING SPECIFY...

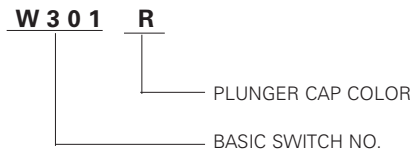

- Plunger Color:
- Gray: GY
- White: W
- Red: R
- Black: No Letter

APPROXIMATE DIMENSIONS - W300

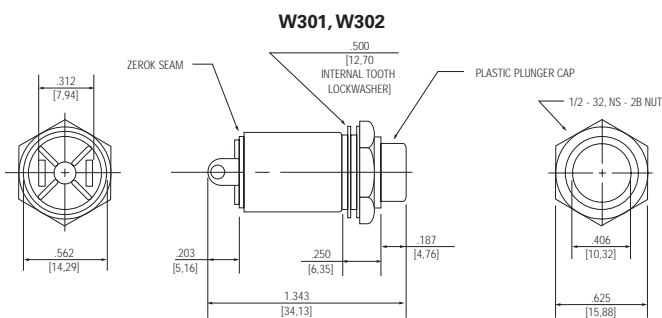

SUPPLIED WITH TWO TERMINAL SCREWS, LOCK WASHERS AND LUGS.

W300 SERIES W/SOLDER TERMINALS

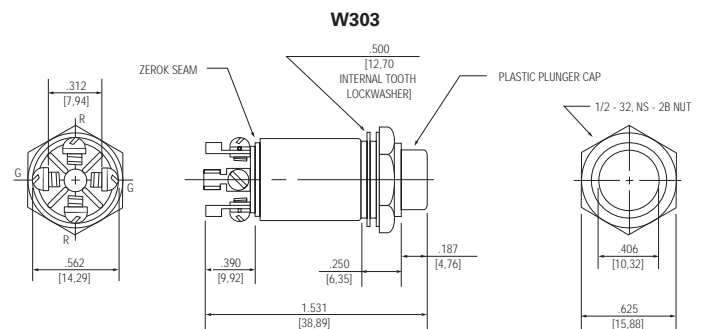

SUPPLIED WITH FOUR TERMINAL SCREWS, LOCK WASHERS AND LUGS.

W300 SERIES W/SOLDER LUG TERMINALS

STANDARD

0.00 = inches

[0,0] = mm

Dimensions for reference only.

Mounting and terminal hardware supplied unassembled.

PUSHBUTTON SWITCHES

Series - W9000

Swivel Action Pushbutton Switches

FEATURES

- Swivel action allows operation from any angle
- Large button
- Splash proof
- Momentary snap action
- Solder lug terminals
- Variety of adapter and button colors

SPECIFICATIONS

- Meets MIL-S-8805 seal level 6 (splash proof)
- Electrical life: 25,000 operations minimum at rated load
- Mechanical life: 200,000 operations (50,000 operations for 3 terminal design)
- Operating force: 4 ± 1 lb ($17.6N \pm 4.4N$)
- Total plunger travel: 0.085 in. (0.22mm) approx.
- Weight with adapter: 0.088 lbs approx.

CURRENT RATINGS

Part Number	Number of Poles	Type of Operation	28VDC [Ⓢ]			120VAC	
			Resistive	Inductive	Lamp	Resistive	Inductive [Ⓢ]
W9000	1	Momentary	10	5	3		15

[Ⓢ] p.f.=.75

[Ⓢ] 3 amps max. through center terminal.

SELECTION TABLE

SERIES AND TYPE



W9000

Base Catalog Number	Operation	Circuit and Schematic	Code Suffixes - Add to Cat. No.			
			Adapter Color		Pushbutton Color	
			Color	Code Suffix	Color	Code Suffix
W9001	Momentary Snap Action	1 P.S.T.-N.O.	Black Clear	None C	Red Black Gray	R B None
W9002		1 P.S.T.-N.C.				
W9003		1 P.-2 Circuit				
W9004		1 P.S.T. 3 Terminal N.O.				
W9005		1 P.S.T. 3 Terminal N.C.				
W9006		1 P.D.T.-N.O.-N.C.				

DIMENSIONS - W9000

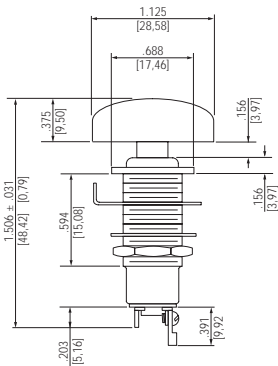

PANEL CUTOUT

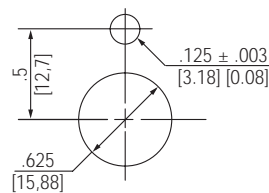

WHEN ORDERING SPECIFY...

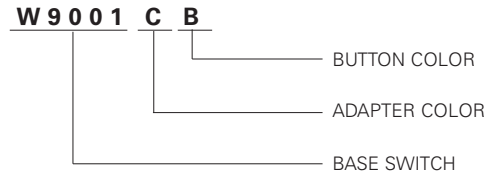

BASIC SWITCH & SCHEMATIC DIAGRAM

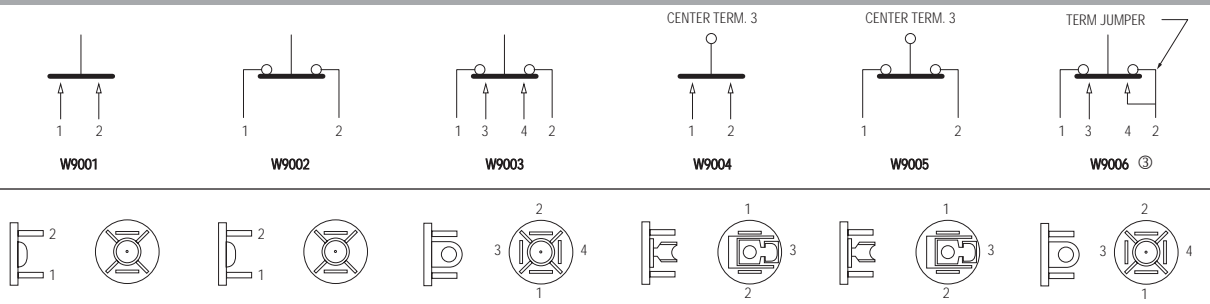

Ⓢ For W9006 or SPDT circuit, mount terminal jumper to terminals #2 and #4.

STANDARD
0.00 = inches
[0,0] = mm

Dimensions for reference only.

Mounting and terminal hardware supplied unassembled.

Series - W9600

Wide Button Moisture-Proof Pushbutton Switches

FEATURES

- Splash-proof
- Wide diameter button
- Variety of button colors available
- Momentary snap action
- Solder lug terminals
- RFI shielded version (W9623)

SPECIFICATIONS

- Meets MILS-8805 seal level 6 (splash-proof)
- Electrical life: 25,000 operations minimum at rated current
- Mechanical life: 200,000 operations (50,000 operations for 3 terminal design)
- Operating force: 4 ± 1 lbs (176N \pm 4.4N)
- Total plunger travel: 0.080 in. \pm .015 (0.21mm \pm .003) approx.
- Vibration: 10-2000Hz 15g.
- Shock: 100g, 6 Ms sawtooth
- Weight with adapter: 0.048 lbs approx.
- EMI/RFI shielded (W9623 only)

CURRENT RATINGS

Part Number	Number of Poles	Type of Operation	28VDC [Ⓢ]			125VAC	
			Resistive	Inductive	Lamp	Resistive	Inductive [Ⓢ]
W9600							
Series	1	Momentary	10	5	3		15
W9623							
Series	2 Circuit	Momentary	10	5	3	—	—

[Ⓢ] p.f. = .75

[Ⓢ] 3 amps max. through center terminal.

SELECTION TABLE

SERIES AND TYPE

W9600



Base Catalog Number	Operation	Circuit and Schematic	Code Suffixes - Add to Cat. No.							
			Adapter Color		Pushbutton Color					
			Color	Code Suffix	Code Suffix	Code Suffix				
W9001	Momentary Snap Action	1 P.S.T.-N.O.	Black	None	Red	R				
W9002		1 P.S.T.-N.C.								
W9003		1 P-2 Circuit								
W9004		1 P.S.T. 3 Terminal N.O.					Clear	C	Black	B
W9005		1 P.S.T. 3 Terminal N.C.							Gray	None
W9006		1 P.D.T.-N.O.-N.C.								

DIMENSIONS - W9600

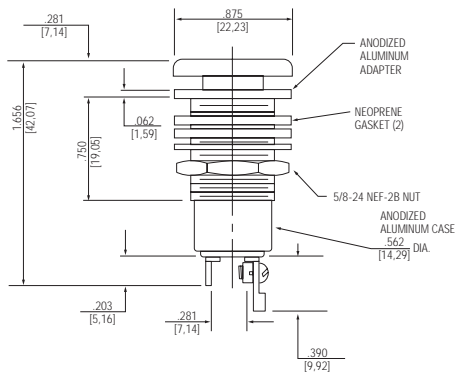

PANEL CUTOUT

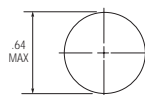

WHEN ORDERING SPECIFY...

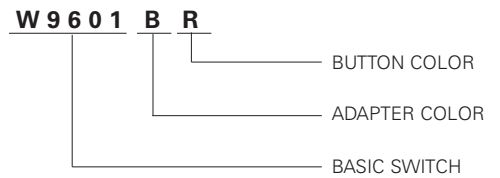

STANDARD

0.00 = inches

[0,0] = mm

Dimensions for reference only.

PUSHBUTTON SWITCHES

Series - W9600

Wide Button Moisture-Proof Pushbutton Switches

BASIC SWITCH & SCHEMATIC DIAGRAM

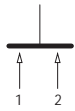

W9601

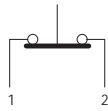

W9602

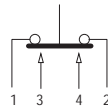

W9603

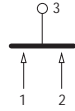

W9604
Center Term 3

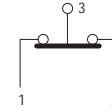

W9605
Center Term 3

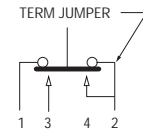

W9606 Ⓞ

Ⓞ For W9606 or SPDT circuit, mount terminal jumper to terminal #2 and #4.



Normally Open



Normally Closed



Two Circuit

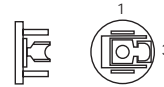

3 Terminal N.O.

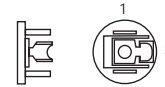

3 Terminal N.C.



S.P.D.T.

TWO CIRCUIT MODEL W9623 EMI/RMI SHIELDED

W9623

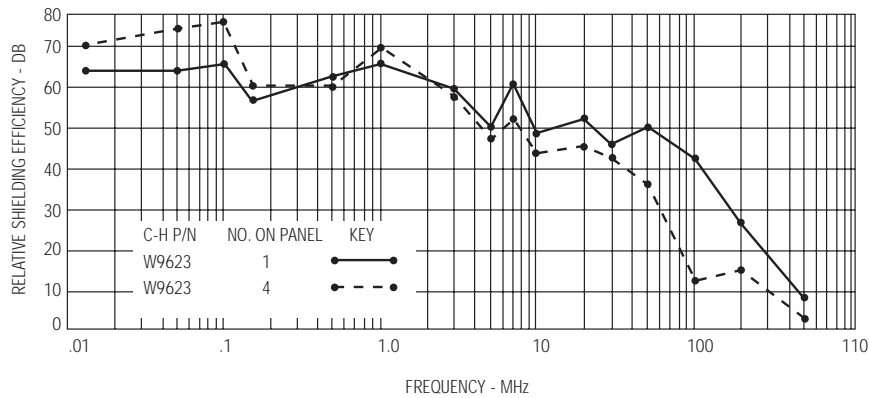
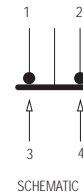
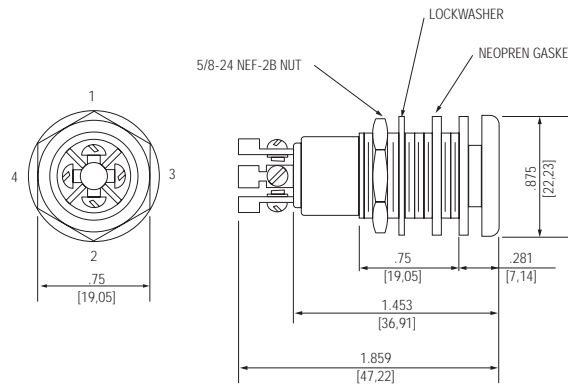

Graphic illustration defines relative shielding efficiency of RFI shielded component/ components over unshielded device.

STANDARD

0.00 = inches

[0,0] = mm

Dimensions for reference only.

FEATURES	SPECIFICATIONS	CURRENT RATINGS					
		Part Number	28VDC			125VAC	
			Resistive Load	Inductive Load	Lamp	Resistive Load	Inductive Load ^③
<ul style="list-style-type: none"> Low level switching capability Moisture-proof Momentary action (except #7 button) Push-Pull action (#7 button only) Up to 1 million mechanical cycles EMI/RFI shielding available Tease resistant, snap action Six circuit arrangements available Various adapter, button styles and colors High contact pressure Compact size Corrosion resistant case and adapters 	<ul style="list-style-type: none"> MS27903 (WC150 series only) Operating temperature: -40°F to +158°F (-40°C to +70°C) Electrical life: 25,000 cycles at rated load Operating force: Approx. 2.5-5 lbs (Momentary) Approx. 1.5-2.5 lbs (Push-Pull) Total plunger travel: 0.085 in. (2.16mm) approx. W100 and WC150 exceeds seal level 2 per MIL-S-8805 C100 series meets seal level 2 per MIL-S-8805 	C100 Series	10 ^①	5	3	10 ^①	5
		W100 Series	10 ^②	5	3	10 ^②	5
		WC1500 Series	—	2	—	—	—
		W403 P6 (R) ^④	10	5	—	—	—

① 3 amps max. through center terminal of A800 and A11200
 ② 3 amps max. through center terminal of W104 and W105
 ③ p.f. = .75
 ④ EMI/RFI shielded

SELECTION TABLE

SERIES AND TYPE

	Circuit	Base Switch - Catalog Number				Options - Suffix Number						
		Solder Lug Terminals				Mounting Adapters		Auxiliary Buttons				
		Non-Sealed		Sealed		Type	Color	Style	Color			
		Normal Force	Light Op. Force (2 +/- .5 lb.)	Normal Force	Light Op. Force (2 +/- 1 lb.)							
C100	SP-NO	C100	C111	—	—	Standard: N, P, PA, W, L (with #5 button only) Optional: D, E, HA, J, M, PL, U, Y	B=Black R=Red No Alpha= Clear	2, 6, or 7	No Alpha= Black R=Red W=White			
	SP-NC	C3100	C112	—	—			On Switch without Adapter				
	1 P.D.T.-2 Ckt.	C200	C113	—	—			2, 3, 4 or 7				
	SP-NO 3 Term.	A800	C114	—	—			On Switches with Adapter				
	SP-NC 3 Term.	A11200	C115	—	—			2, 3, 4, 6 or 7				
1 P.D.T. Dbl Brk	C4100	C116	—	—	6							
W100	SP-NO	—	—	W101	W111			Standard: N, P, PA, W, L (with #5 button only) Optional: D, E, HA, J, M, PL, U, Y		B=Black R=Red No Alpha= Clear	2, 3, 4, 6 or 7	No Alpha= Black R=Red W=White
	SP-NC	—	—	W102	W112						2, 3, 4, 6 or 7	
	1 P.D.T.-2 Ckt.	—	—	W103	W113						6	
	SP-NO 3 Term.	—	—	W104	W114						2, 3, 4, 6 or 7	
	SP-NC 3 Term.	—	—	W105	W115	6						
	1 P.D.T. Dbl Brk	—	—	W106	W116	2, 3, 4, 6 or 7						
1 P.D.T.-2 Ckt.	—	—	—	—	6							
WC150	2 P.D.T. 4 Ckt. May be Jumpered for 2 P.D.T.	—	—	WC150	—				2, 3, 4, 6 or 7			

WHEN ORDERING SPECIFY...

• Catalog number of base switch - followed by suffix numbers of options (when required) as selected from Selection Table.

Order Example:

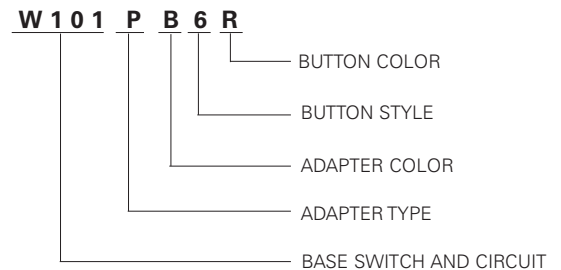
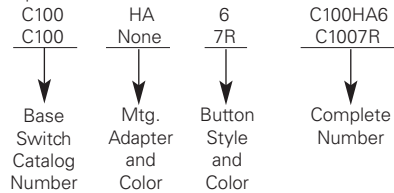

STANDARD

0.00 = inches

[0,0] = mm

Dimensions for reference only.

PUSHBUTTON SWITCHES

Series - C100, W100, WC150

Uniform Panel Appearance Switches

APPROXIMATE DIMENSIONS - PUSHBUTTON SWITCHES

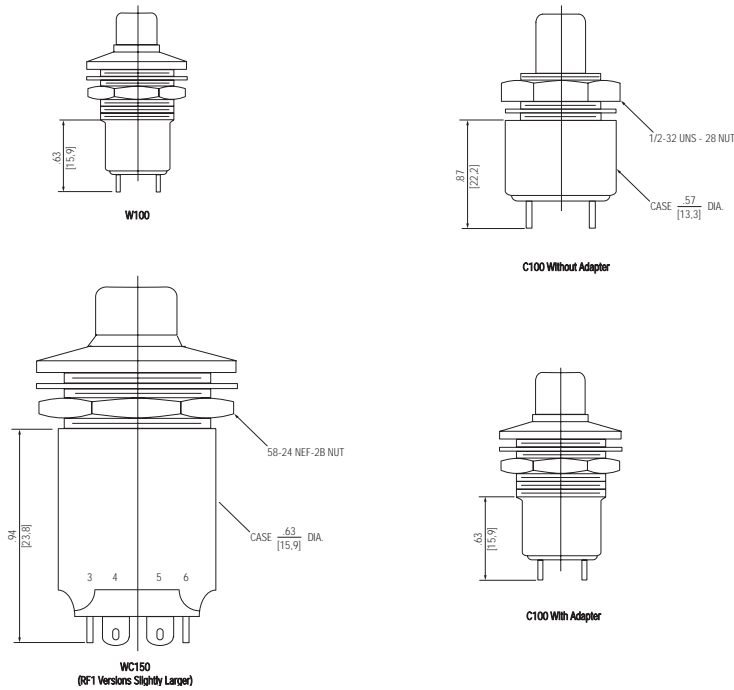

APPROXIMATE DIMENSIONS - AUXILIARY BUTTONS

	Style Number 2		Style Number 3		Style Number 4		Style Number 6		Style Number 7	
	A	B	A	B	A	B	A	B	A	B
Series Number	mm.	in.	mm.	in.	mm.	in.	mm.	in.	mm.	in.
Series C100										
Without Adapter	7.9	.31	-	-	-	-	7.9	.31	4.8	.19
With Adapter	9.5	.37	7.9	.31	9.5	.37	4.8	.19	7.9	.31
Series W100 & WC150										
With Adapter	9.5	.37	7.9	.31	9.5	.37	6.4	.25	9.5	.37
Without Adapter		.37		.34		.37		.38		.41

SCHEMATIC DIAGRAMS

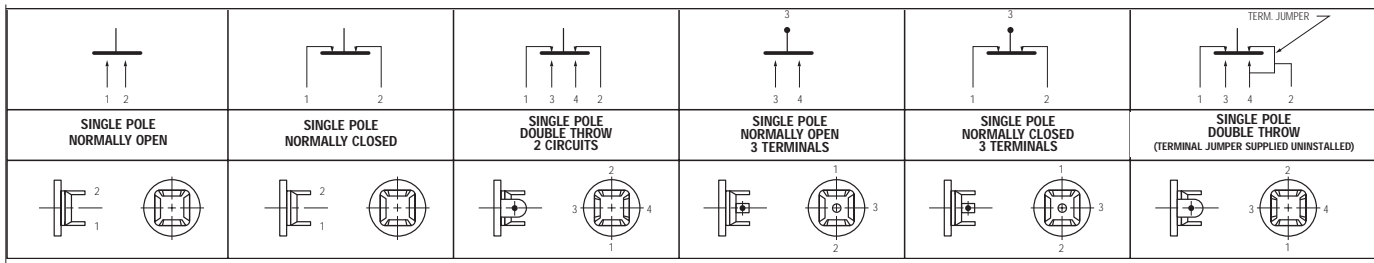

STANDARD

0.00 = inches

[0,0] = mm

Dimensions for reference only.

APPROXIMATE DIMENSIONS - MOUNTING ADAPTERS

STANDARD:

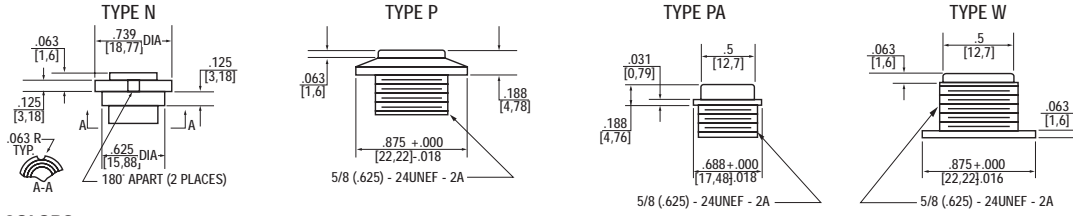

PLUNGER CAP COLORS:

CHROME: NO LETTER
 RED: R
 BLACK: B
 TOTAL PLGR TRAVEL: .438 APPROX.
 OVERTRAVEL: .313 APPROX.

TYPE L WITH 5 PLUNGER CAP

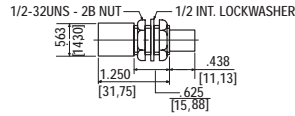

OPTIONAL:

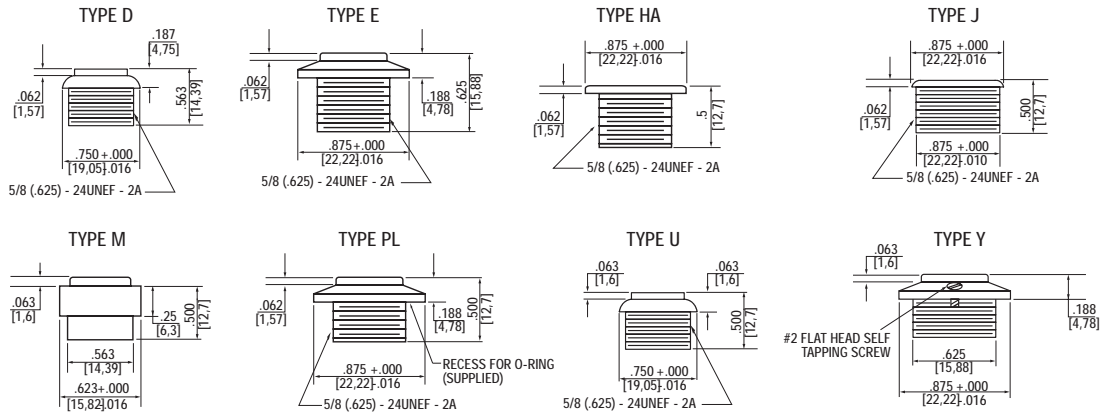

NOTE: INTERNAL THREADS 1/2 - 32 UNS-2B

EMI/RFI SHIELDED



W1501

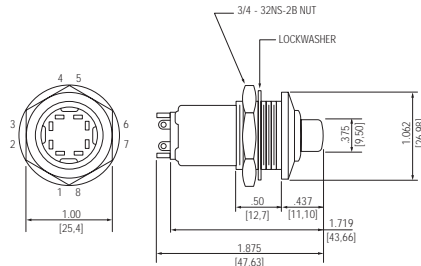

SCHEMATIC

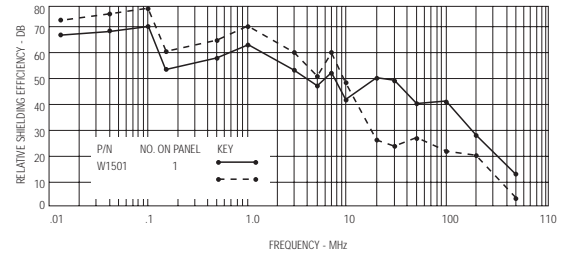
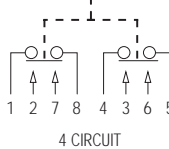

Graphic Illustration defines relative shielding efficiency of RFI shielded component/ components over unshielded device.



W403P6

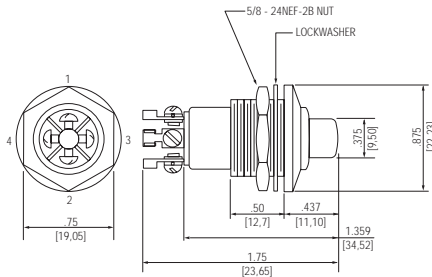

SCHEMATIC

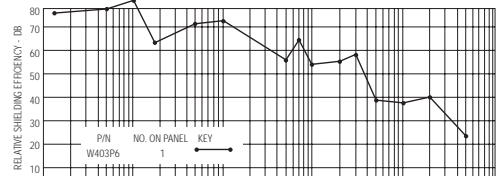
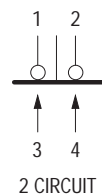

Graphic Illustration defines relative shielding efficiency of RFI shielded component/ components over unshielded device.

STANDARD
 0.00 = inches
 [0,0] = mm

Dimensions for reference only.

PUSHBUTTON SWITCHES

Sub-Miniature Pushbutton Switches

FEATURES

- Sealed or unsealed versions
- Low operating force
- Momentary snap action
- EMI/RFI version (BR7070)
- Black or red adapter colors available
- Clear or black case colors available
- Compact, space saving design

SPECIFICATIONS

- MIL-S-8805 approved
- Total plunger travel: .08/0.093 in. (0.236 mm) minimum
- Electrical life: 25,000 operations minimum at de-rated current
10,000 operations minimum at rated current
- Operating force:
 - B9000 1.5 (6.66N) ± .5 lb (2.22N)
 - BW9000, B9020 & BW9020 1.75 (7.77N) ± .5 lb (2.22N)
 - B7070 1.5 (6.66N) ± .75 lb (3.33N)
 - BR7070 2.0 (8.88N) ± .75 lb (3.33N)
- Weight approx.:
 - B9000 0.01 lb (4.5g) Max. & B9020
 - BW9000 0.01 lb (4.5g) Max. & BW9020
 - B7070 0.02 lb (9.1g) Approx.
 - BR7070 0.02 lb (9.1g) Max.
- EMI/RFI shielded (BR7070 only)

CURRENT RATINGS

Part Number	Number of Poles	Type of Operation	28VDC		125VAC	
			Resistive Load	Inductive Load	Resistive Load	Inductive Load ^①
B9001	1	Momentary	7	4	7	4
B9002	1	Momentary	7	4	7	4
BW9001	1	Momentary	7	4	7	4
BW9002	1	Momentary	7	4	7	4
B9021	1	Momentary	7	4	7	4
B9022	1	Momentary	7	4	7	4
BW9021	1	Momentary	7	4	7	4
BW9022	1	Momentary	7	4	7	4
B7070	2	Momentary	1	1	1	1
BR7070 ^②	2	Momentary	1	1	1	1

^① p.f. = .75

^② EMI/RFI shielded

APPROXIMATE DIMENSIONS

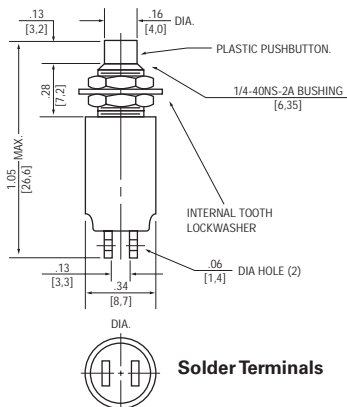

**B9001, 2
Single Pole**

SELECTION TABLES

Catalog Number	Military Part Numbers M8805/96	Button Color	Circuit	Case Color	Enclosure Design
B9001R	-001	Red	SPST-NO	Clear	(unsealed)
B9001B	-002	Black	SPST-NO	Clear	(unsealed)
B9002R	-003	Red	SPST-NC	Clear	(unsealed)
B9002B	-004	Black	SPST-NC	Clear	(unsealed)
B9001BR	-005	Red	SPST-NO	Black	(unsealed)
B9001BB	-006	Black	SPST-NO	Black	(unsealed)
B9002BR	-007	Red	SPST-NC	Black	(unsealed)
B9002BB	-008	Black	SPST-NC	Black	(unsealed)
BW9001R	-009	Red	SPST-NO	Clear	(dust tight)
BW9001B	-010	Black	SPST-NO	Clear	(dust tight)
BW9002R	-011	Red	SPST-NC	Clear	(dust tight)
BW9002B	-012	Black	SPST-NC	Clear	(dust tight)
BW9001BR	-013	Red	SPST-NO	Black	(dust tight)
BW9001BB	-014	Black	SPST-NO	Black	(dust tight)
B9002BR	-015	Red	SPST-NC	Black	(dust tight)
B9002BB	-016	Black	SPST-NC	Black	(dust tight)

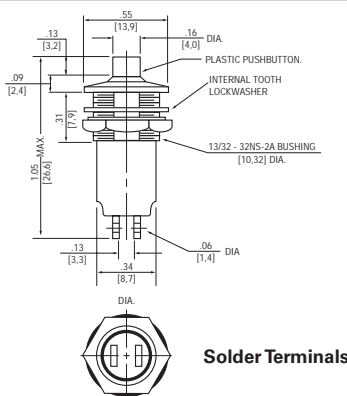

**B9021, 22
Single Pole**

Catalog Number		Circuit	Case Color	Button Color
Standard	Dust Tight			
B9021CB	BW9021CB	SP-NO	Clear	Black
B9021CR	BW9021CR			Red
B9021BB	BW9021BB			Black
B9021BR	BW9021BR	SP-NC	Clear	Red
B9022CB	BW9022CB			Black
B9022CR	BW9022CR			Red
B9022BB	BW9022BB			Black
B9022BR	BW9022BR	Black	Red	

SCHEMATIC DIAGRAMS - B AND BW SERIES

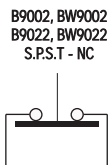

PANEL CUT-OUT

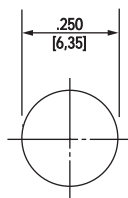

PANEL MTG HOLE DIMENSIONS

PANEL CUT-OUT

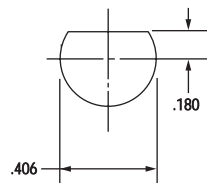

B9021, BW9021, B9022, BW9022
PANEL MTG HOLE DIMENSIONS

SERIES TYPE

APPROXIMATE DIMENSIONS

SELECTION TABLES



B7070
Two Pole

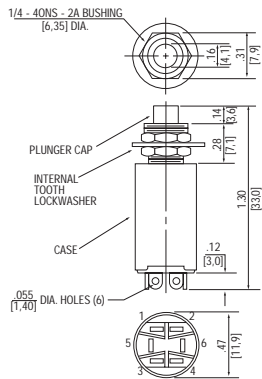

Solder Terminals

Catalog Number	Military Part Number	Case Color	Button Color
B7070	M8805/95-001	Clear	Black
B7070R	M8805/95-002	Clear	Red
B7070B	M8805/95-003	Black	Black
B7070BR	M8805/95-004	Black	Red

SCHEMATIC DIAGRAMS - B7070

PANEL CUT-OUT

D.P.D.T.

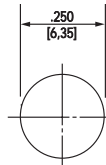
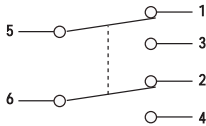

PANEL MTG HOLE DIMENSIONS



BR7070
Two Pole

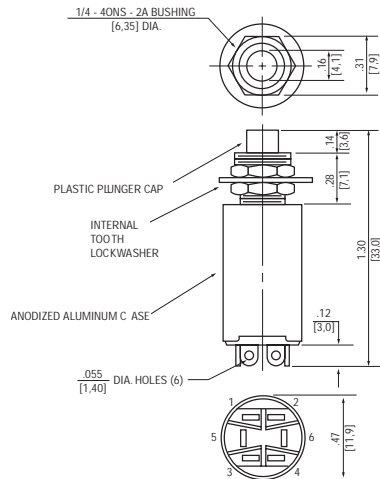

Solder Terminals

Catalog Number	Case Color	Button Color
BR7070	Clear	Black
BR7070R	Clear	Red
BR7070B	Black	Black
BR7070BR	Black	Red

*EMI/RFI shielded

SCHEMATIC DIAGRAMS - B7070

PANEL CUT-OUT

D.P.D.T.

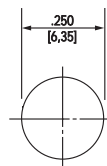
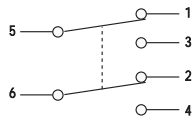

PANEL MTG HOLE DIMENSIONS

STANDARD

0.00 = inches

[0,0] = mm

Dimensions for reference only.

PUSHBUTTON SWITCHES

Series - A20000 Momentary Snap Action J20000 Push-Push (Alternate) Action

Illuminated Switches

FEATURES

- Moisture resistant
- Flame retardant back material
- Low operating force
- Independent lamp circuit
- Rugged case
- A20000 Series Momentary Snap Action
- J20000 Series Alternate Action

SPECIFICATIONS

- Drip-proof enclosure design level 2
- Per MIL-PRF-22885/18
- Temperature Range: -67°F to +185°F (-55°C to +85°C)
- Operating Force: 2 ± 1 lb (8.88N)
- Plunger travel: 0.160 in. (4.06mm) approx.
- Uses either M22885/19 screw type or snap-in type lenses per MIL-PRF-22885/99.
- Uses T-1-3/4 Midget Flange Base, Incandescent Lamp

CURRENT RATINGS

Part Number	Number of Poles	Type of Operation	28VDC			115VAC 60/400 Hz		
			Resistive	Inductive	Lamp	Resistive	Inductive	Lamp
J20000	2	Alternate	2	1.5	0.5	2	1.5	0.5
A20000	2	Momentary	2	1.5	0.5	2	1.5	0.5

SELECTION TABLE

APPROXIMATE DIMENSIONS

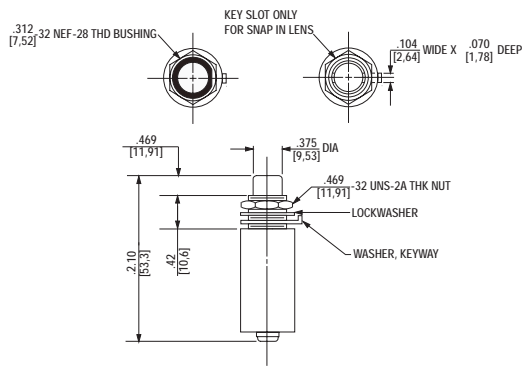

Catalog Number	Circuit	Lens Type	Detail Sheet	Spec.
Alternate Action				
J20145	2 P.D.T.	Screw-in	M22885/18-02	
J20149	2 Circuit			-04
J20152	2 P.D.T.	Snap-in	M22885/18-06	
J20153	2 Circuit			-08
Momentary Action				
A20267	2 P.D.T.	Screw-in	M22885/18-01	
A20271	2 Circuit			-03
A20272	2 P.D.T.	Snap-in	M22885/18-05	
A20273	2 Circuit			-07



*NOTE: Catalog number does not include lens shown above.

SCHEMATIC DIAGRAMS - A20000 AND J20000

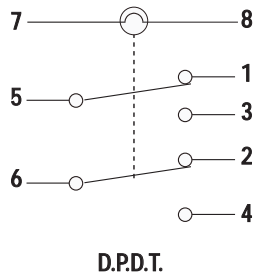
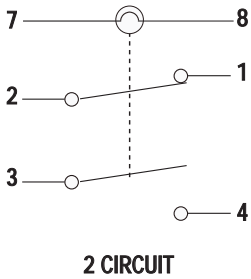

RECOMMENDED PANEL MOUNTING HOLE DIMENSIONS

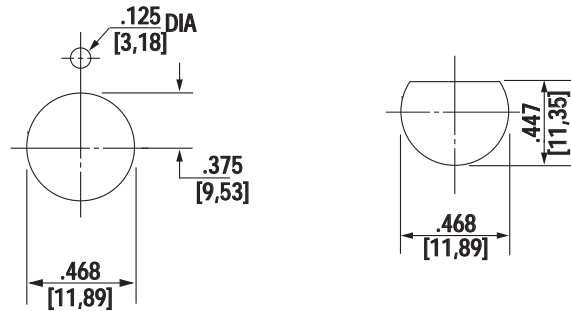

STANDARD

0.00 = inches

[0,0] = mm

Dimensions for reference only.

FEATURES	SPECIFICATIONS	CURRENT RATINGS							
		Catalog Number	Type of Operation	28VDC			115VAC 60 or 400Hz		
Resistive Load	Inductive Load			Lamp Load	Resistive Load	Inductive Load	Lamp Load		
<ul style="list-style-type: none"> • High strength handles and caps • Control stick mounted on hand-held grips • Trigger-operated pushbutton switches in handle • Positive action, double break trigger switch • Auxiliary switch in cap on 8895K1 • Catalog part numbers 8895 and 8896 mount to control stick • Catalog part number 8897 features a hand strap for multi-task capability 	<ul style="list-style-type: none"> • High impact Thermoset molding materials used in handles and caps • Temperature Range: -67°F to +150°F (-55°C to +65°C) • Life: 10,000 operations at rated load 10,000 operations mechanical life 	8895K1	Trigger PB sw	40	35	5	30	20	3
			Auxiliary PB sw	20	15	1.5	11	11	1
		8896K1	Trigger PB sw	40	35	5	30	20	3
		8897K1	Trigger PB sw	40	35	5	30	20	3
		8899K ^①	Pushbutton sw	10	5	3	—	—	—

^① Contact Customer Service for product information 800/955-7354, 941/751-7138, Fax 941/751-7173.

SELECTION TABLE



Type	Poles and Throw	Circuit Arrangement		Features	Government Drawing Number	Catalog Number
		Normal	Depressed			
Pistol Grip	1 P.S.T.	OFF	ON *	— With Auxiliary Switch With Hand Strap	NAF1173-1 NAF1173-2 NAF1174-1	8896K1 8895K1 8897K1

* Momentary Contact

PUSHBUTTON SWITCHES

Series - 8895-8897, 8899

Hand Controls with Pushbutton Switches

APPROXIMATE DIMENSIONS - 8895K1

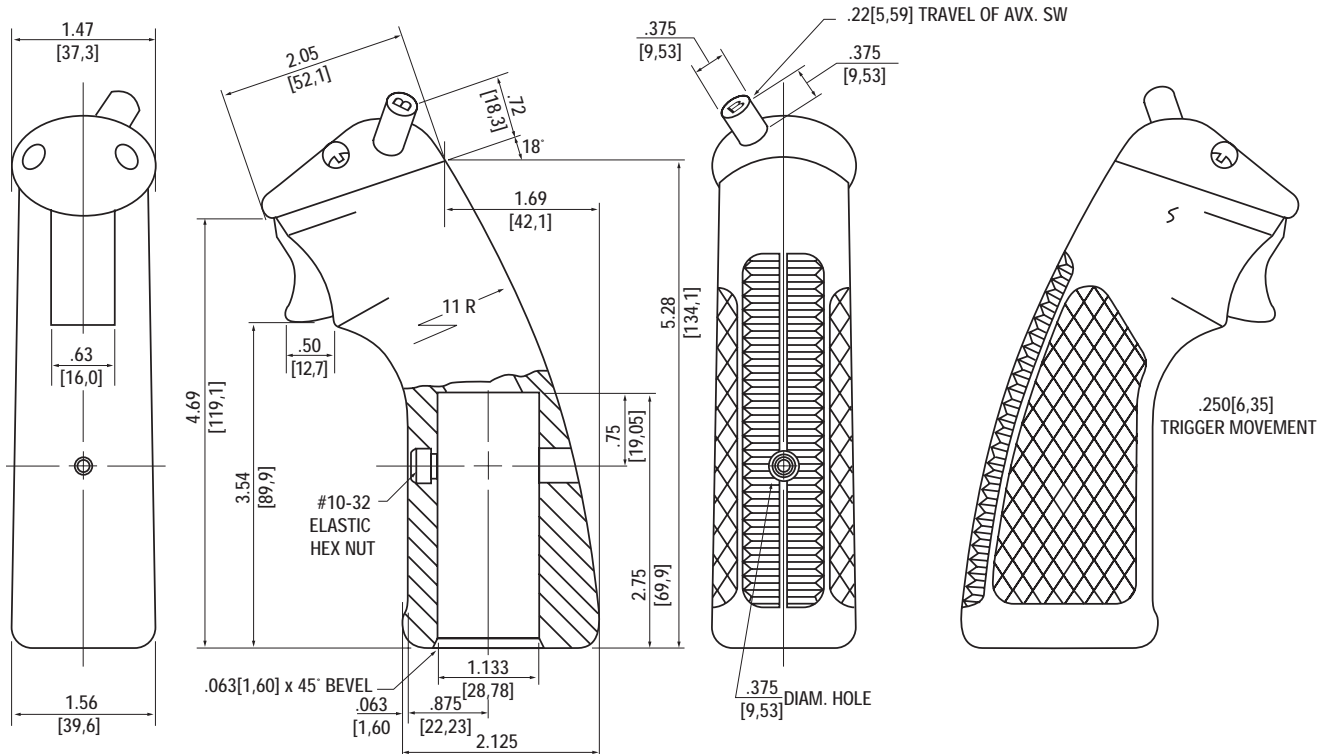

APPROXIMATE DIMENSIONS - 8896K1

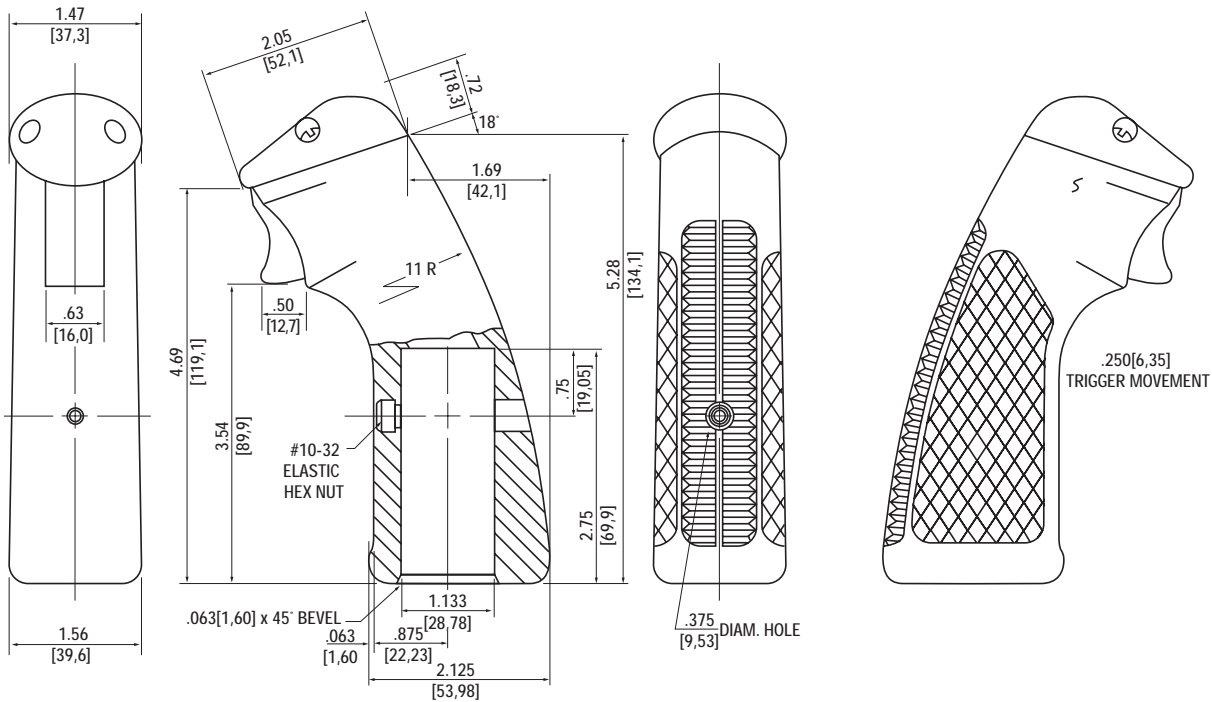

STANDARD

0.00 = inches

[0,0] = mm

Dimensions for reference only.

APPROXIMATE DIMENSIONS - 8897

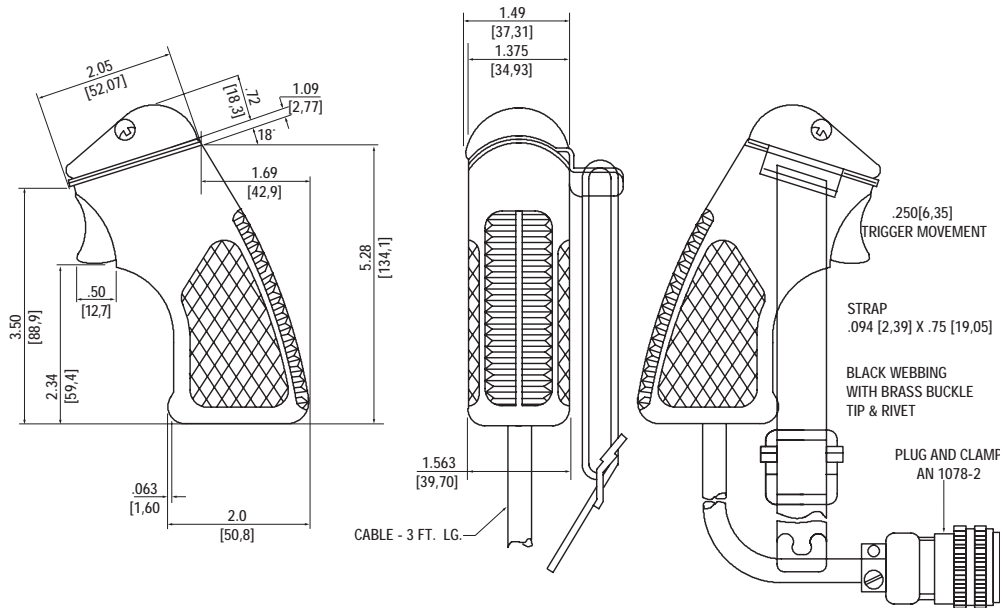

APPROXIMATE DIMENSIONS - 8899

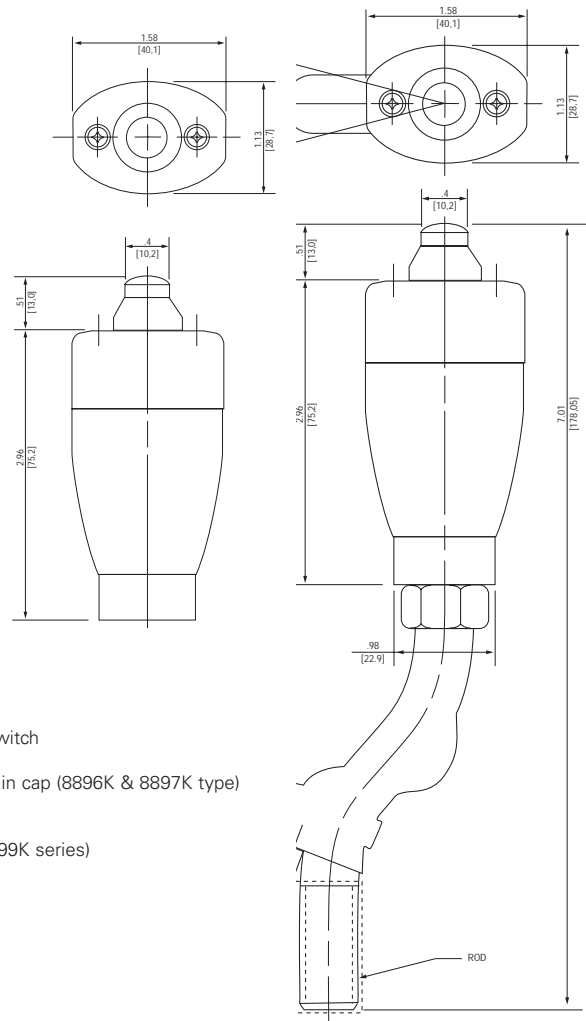

8899K 2.AI

OPTIONS/ACCESSORIES

- Replace trigger switch with sealed pushbutton switch
- Harness assemblies available
- Auxiliary toggle or pushbutton switches installed in cap (8896K & 8897K type)
- Multi-function switch variations
- Replacement components
- Joystick or hand-held configurations available (8899K series)

STANDARD
 0.00 = inches
 [0,0] = mm

Dimensions for reference only.

PUSHBUTTON SWITCHES

Series - 8870, 8809

Special Designed Pushbutton Switches

FEATURES	SPECIFICATIONS	CURRENT RATINGS						
		Catalog Number	28VDC			115VAC 60 or 400Hz		
<ul style="list-style-type: none"> All switches employ momentary action Foot or hand operation designs Plunger has ice and mud scraper Mechanical lock on 8909K559 Mechanical lock has spring loaded release design Logic to power switching load capability 	<ul style="list-style-type: none"> MS approved and QPL'd to MIL-S-8805 Temperature Range: -40°F to +185°F (-40°C to +85°C) Life: 20,000 operations at rated load 50,000 operations mechanical life 			Resistive Load	Inductive Load	Lamp Load	Resistive Load	Inductive Load
		8870K2	25	10	4	15	7.5	2
		8870K3	25	10	4	15	7.5	2
		8870K4	25	10	4	15	7.5	2
		8870K5	25	10	4	15	7.5	2
		8909K559	6	—	—	6	—	—

SELECTION TABLE



8870K2 & K4



8870K3 & K5



8909K559

Poles and Throw	Circuit Arrangement		Mounting	Features	Government Part Number	Catalog Number
	Normal	Depressed				
1 P.S.T.	OFF	ON*	Flush ^②	Microphone PB Switches Foot Operated	M8805/55-001	8870K2
					M8805/55-002	8870K3
					M8805/55-003	8870K4
					M8805/55-004	8870K5
2 P.S.T.	OFF	ON*	Flush ^②	Roller Operated	—	8909K559 ^①

* Momentary contact.

^① Electrical life of 8909K559 is 12,000 operations.

^② See page B25 for mounting data.

OPTIONS/ACCESSORIES

- Terminal screws furnished assembled
- Double throw contacts - 8870
- Special marking

APPROXIMATE DIMENSIONS - 8870K2, K3, K4, K5

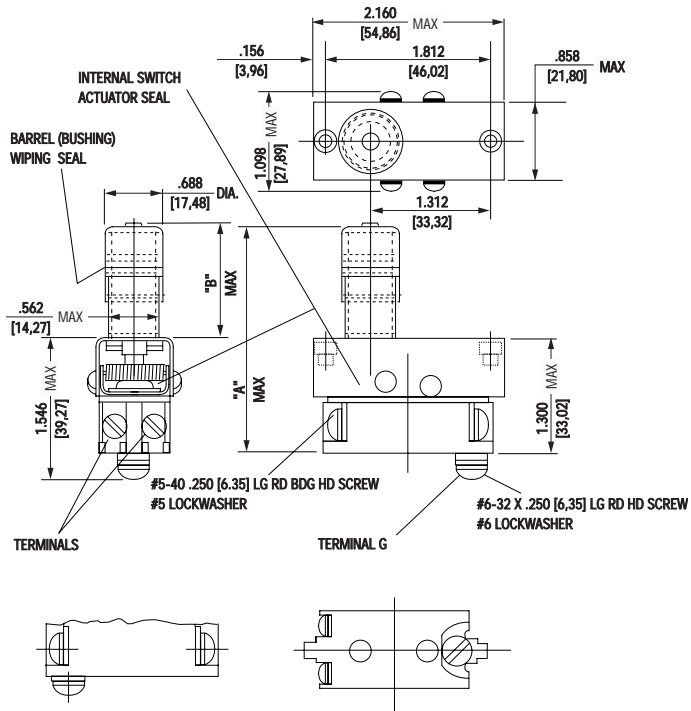

8870K5	2.968	1.660	6-32 UNC-2B
8870K4	2.218	.910	6-32 UNC-2B
8870K3	2.968	1.668	6-40 UNF-2B
8870K2	2.218	.910	6-40 UNF-2B
CAT.NO.	A	B	INSERT & NUT THREAD

APPROXIMATE DIMENSIONS - 8909K559

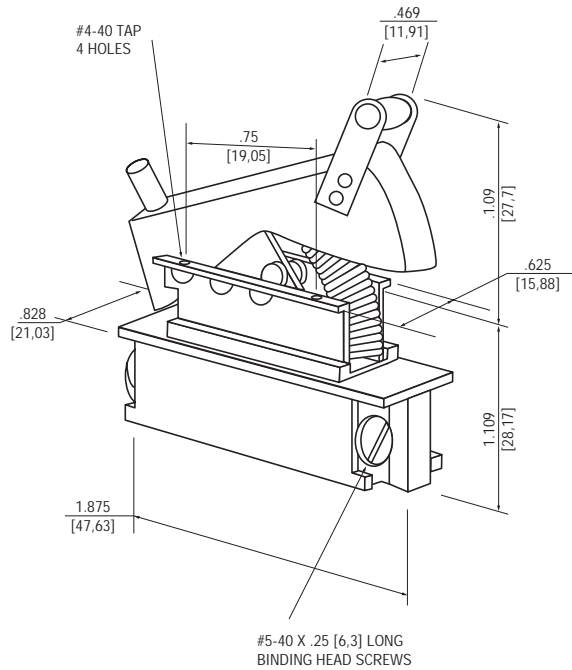

STANDARD

0.00 = inches

[0,0] = mm

Dimensions for reference only.

Index

C-1

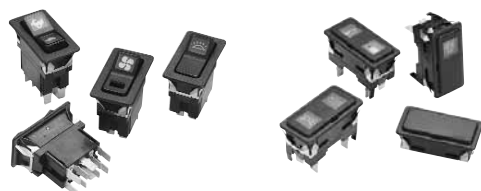
**Illuminated Rocker Switches**

C2 - C8

- Watertight seal per MIL-STD-108E
- One and two pole arrangements
- Standard rocker and locking style actuation
- Switch is front panel mounted
- Lamps can be wired with circuit or independently
- Complete accessory package available

**Econoswitch Rocker Switches**

C9 - C18

- Watertight seal per MIL-STD-108E
- Two styles - Pinned Rocker and Removable Rocker
- Three types of panel mounting
- Ratings at 28VDC and 115VAC 60/400 Hz
- One, two and four pole arrangements
- Multi-circuits
- Terminal variations - screw, spade and solder lug
- 2 & 3 position with maintained and momentary action

**Industrial Rocker Switches**

C19 - C21

- Watertight seal per MIL-STD-108E
- Three styles of panel mounting
- Ratings at 28VDC and 115VAC 60/400 Hz
- One, two and four pole arrangements
- Multi-circuits
- 2 & 3 position with maintained and momentary action
- Pinned rocker actuation furnished in opaque colors

**Military Rocker Switches**

C22 - C25

- Environmentally sealed per MIL-S-3950
- MS approved and QPL listed per MIL-S-3950
- One, two and four pole arrangements
- Two panel mounting variations
- Multi-circuits
- Ratings at 28VDC and 115VAC 60/400 Hz
- Removable rocker button
- Variety of opaque colored Actuator

Ratings and Circuit Arrangements

C26 - C31

**Most items listed in this catalog are standard products and are normally in Distributor Inventory; however, the current inventory status should be checked by contacting your Eaton Customer Service Representative at 800-955-7354 or your authorized Distributor before placing orders.*

"ILLUMINATER™ " SERIES SEALED ROCKER SWITCHES

DESCRIPTION

The new Illuminator series of front panel mounted rocker switches are sealed to meet the watertight requirements of MIL-STD-108E. Product variations are with standard or locking rocker Actuator, and single or double pole switching with multi-circuits. A variety of accessory items are also available. This product is ideally suited for use in harsh environmental applications.

DESIGN FEATURES

- Front panel mounted
- Totally sealed switching chamber
- Various circuit variations
- Keyed assembly - actuator to bezel and base to connector
- Removable rocker button
- One or two lamp capability
- Full size clear lens with non-glare surface
- Icons located beneath lens surface (high wearability)
- Diffusion lens alters icon background lighting
- Minimum light leakage
- Various locking styles available
- Matte black textured finish on bezel/actuator
- Molded-in terminal identification
- Molded-in orientation mark

SPECIFICATIONS

- Watertight per MIL-STD-108E
- Temperature range: -40°F to +160°F (-40°C to +71°C)
- Dielectric strength 1800 V RMS @ sea level
- Life: 50,000 cycles min. electrical; 100,000 cycles min. mechanical
- Silver plated contact - standard
- Flame retardant thermoplastic bezel and base
- Stainless steel mounting clips



ACCESSORIES

- Indicator light assembly (see page C7)
- Filler plug (see page C6)
- Connector (see page C7)
- Gang mounting system

OPTIONS

- Non-illuminated switch
- Gold plated contacts

SINGLE POLE ELECTRICAL RATINGS

Type of Operation	6 & 14VDC			28VDC		
	Resistive Load	Inductive Load	Lamp Load	Resistive Load	Inductive Load	Lamp Load
Maintained	25	15	7.5	20	15	5
Momentary	20	10	6	15	10	4

DOUBLE POLE ELECTRICAL RATINGS

Type of Operation	6 & 14VDC			28VDC		
	Resistive Load	Inductive Load	Lamp Load	Resistive Load	Inductive Load	Lamp Load
Maintained	30	20	10	20	15	7
Momentary	25	15	7.5	18	10	5

DIMENSIONS

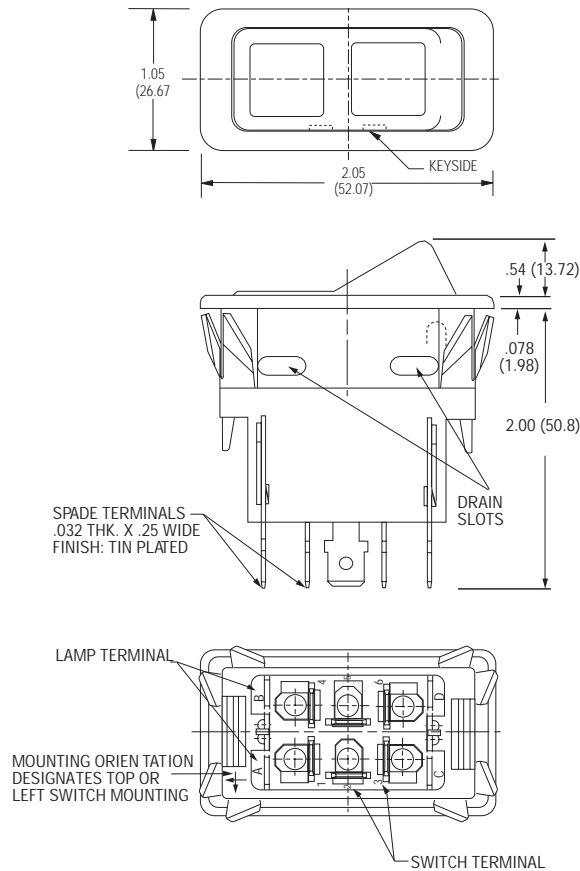

Note: For recommended panel cutout dimensions, see page C7.

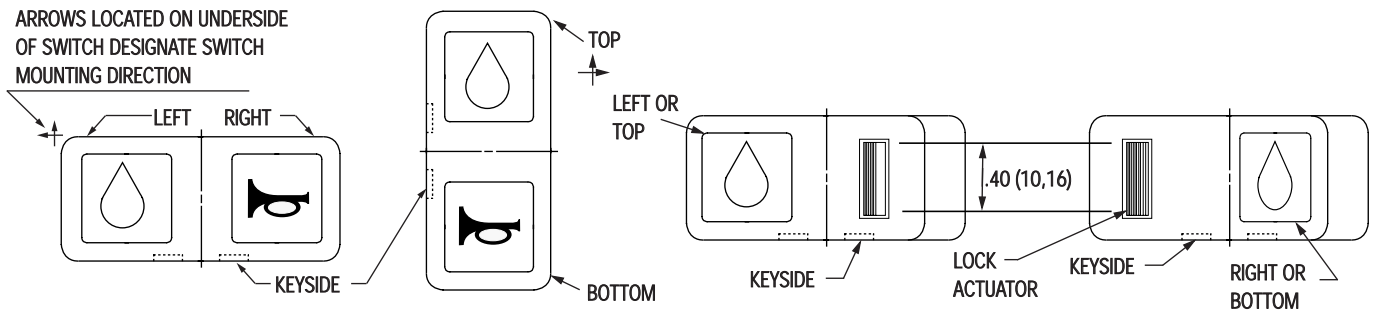

FIGURE 1
Horizontal Mount

FIGURE 2
Vertical Mount

FIGURE 3
Locking Actuator Styles 4, 5, Y, & T

FIGURE 4
Locking Actuator Styles 6, 7, W, & S

"ILLUMINATER™" SERIES PART NUMBERING SYSTEM

ACTUATOR STYLE (See Page C3, Figs 1-4)

Code	Style
1	(1) Lens Top or Left
2	(1) Lens Bottom or Right
3	(2) Lenses
4	Lock in both End Positions w/ Lens (or Plain Surface) Top or Left
5	Lock in Center Position w/ Lens (or Plain Surface) Top or Left
6	Lock in Both End Positions w/ Lens (or Plain Surface) Bottom or Right
7	Lock in Center Position w/Lens (or Plain Surface) Bottom or Right
A	Plain Rocker Button (No Lenses)
S	Lock in (1) End Position w/ Lens (or Plain Surface) Bottom or Right (Lens or Plain Surface Locked in "UP" Position)
T	Lock in (1) End Position w/ Lens (or Plain Surface) Top or Left (Lens or Plain Surface Locked in "UP" Position)
W	Lock in (1) End Position w/ Lens (or Plain Surface) Bottom or Right (Lens or Plain Surface Locked Actuated Position)
Y	Lock in (1) End Position w/ Lens (or Plain Surface) Top or Left (Lens or Plain Surface Locked Actuated Position)

ICON (Location - Top or Left "only") (See Page C8 for Icon Selection Table)

Code	Function
DF	Oil
(Code "ZZ" = No Icon)	

ICON (Location - Bottom or Right "only") (See Page C8 for Icon Selection Table)

Code	Function
BF	Horn
(Code "ZZ" = No Icon)	

DIFFUSION LENS COLOR (Location - Top or Left "only")

Code	Color
0	None
1	Amber
2	Blue
3	Green
4	Red
5	White
6	Clear

DIFFUSION LENS COLOR (Location - Bottom or Right "only")

Code	Color
0	None
1	Amber
2	Blue
3	Green
4	Red
5	White
6	Clear

BAFFLE

(Light Intensity Deflector)

Code	Color
A	(1) Top or Left
B	(1) Bottom or Right
C	(2) Baffles
Z	None

ACTUATOR MOUNTING POSITION & COLOR

Code	Orientation
F	Optional / Black (Plain Actuator no Lenses)
H	Horizontal / Black
V	Vertical / Black

B 01 A 5 J H 3 DF 2 ZZ 3 Z = B01A5JH3DF2ZZ3Z

NO. OF POLES

Code	Selection
A	Single
B	Double

OPTIONAL FEATURES

Code	Option
A	Silver Contacts
G	Gold Contacts

ROCKER TYPE

Code	Type
5	Illuminated
6	Non - Illuminated
7	Locking Feature Illuminated
8	Locking Feature Non-Illuminated

LAMP SELECTION

Code	Voltage	No. Lamps	Location
D	14VDC	1	Top or Left
E	14VDC	1	Bottom or Right
F	14VDC	2	Both Locations
G	28VDC	1	Top or Left
H	28VDC	1	Bottom or Right
J	28VDC	2	Both Locations
K	See⓪	1	Top or Left
L	See⓪	1	Bottom or Right
M	See⓪	2	Both Locations
Z	Non - Illuminating		

⓪ Furnished without lamps. Provisions for lamp available as indicated under location.

CIRCUIT ARRANGEMENT

Code	Top			Available Locking Configuration	Code	Bottom			Available Locking Configuration
	or Left	Center	or Right			or Left	Center	or Right	
01	On	Off	On	4,5,6,7,Y,T,S	* 15	On	On	Mom On	5,7,Y,S
02	Mom On	Off	Mom On	5,7	* 16	Mom On	On	Mom On	5,7
03	On	Off	Mom On	5,7,Y,S	50	Mom On	Off	On	5,7,W,T
04	On	None	On	4,6,Y,W,T,S	51	Mom On	None	On	W,T
05	On	None	Mom On	Y,S	52	None	Off	On	7,W
06	On	Off	None	5,Y	53	Mom On	Off	None	5
07	None	Off	Mom On	7	54	None	Mom Off	On	W
08	On	Mom Off	None	Y	55	Off	None	On	4,6,Y,W,T,S
09	On	None	Off	4,6,Y,W,T,S	56	Mom Off	None	On	W,T
10	On	None	Mom Off	Y,S	57	Mom On	None	Off	W,T
11	Off	None	Mom On	Y,S	58	None	On	Mom On	7
12	Mom On	On	None	5	59	None	On	On	7,W
13	On	On	None	5,Y	* 60	Mom On	On	On	5,7,W,T
* 14	On	On	On	4,5,6,7,Y,W,T,S	* Double pole switches only				

PART NUMBER WORKSHEET

No. of Poles	Circuit Arrangement	Bezel Color	Bezel Style	Lamp Selection	Mounting Position	Actuator Style	Icon - Top or Left	Diffusion Lens Color	Icon - Bottom or Right	Diffusion Lens Color	Diffusion Lens Color
B	01	A	5	J	H	3	DF	2	ZZ	3	Z

DESCRIPTION

Along with this new line of illuminated rocker switches, we also offer a line of accessories. General styling and appearance match those of the basic switch, with design features as stated.

DESIGN FEATURES

Indicator

- Front panel mounted
- Keyed assembly
 - indicator lens assembly to bezel
 - connector to bezel superstructure
- Removable indicator lens assembly
- One or two lamp capability
- Full size clear lens with non-glare surface
- Icons located beneath lens surface
- Diffusion lens alters icon background lighting
- Matte black textured finish on indicator assembly
- Molded-in terminal identification
- Molded-in orientation mark

SPECIFICATIONS / MATERIALS

- Temperature range: -40°F to +160°F (-40°C to +71°C)
- Flame retardant thermoplastic bezel and base
- Stainless steel mounting clips



OTHER ACCESSORIES

- Connector (see page C7)

FILLER PLUG

- Front panel mounted
- Accepts - connector/harness assembly
- Matte black textured finish

"ILLUMINATER™ " SERIES INDICATOR AND ACCESSORIES ENGINEERING DATA

INDICATOR

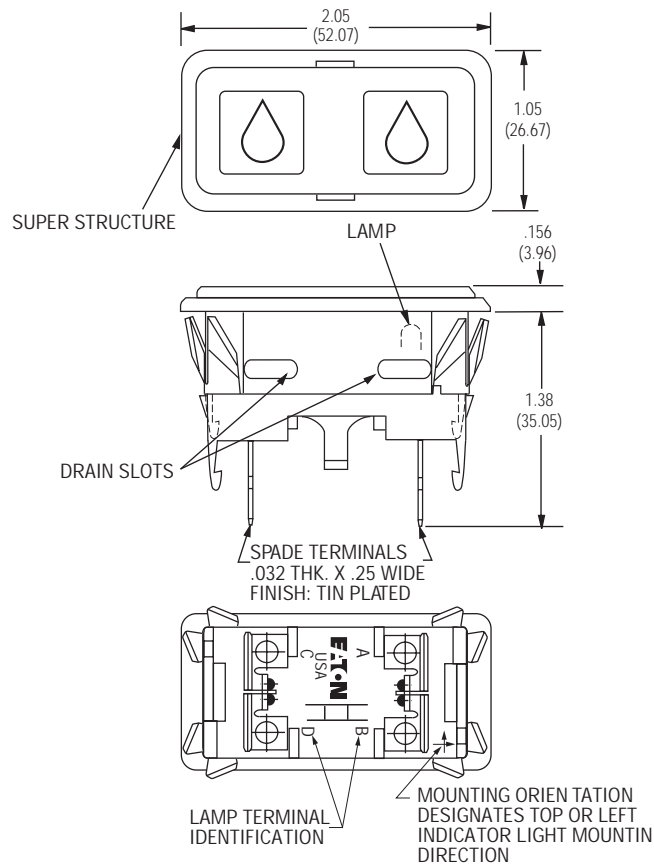

FILLER PLUG - P/N P24010

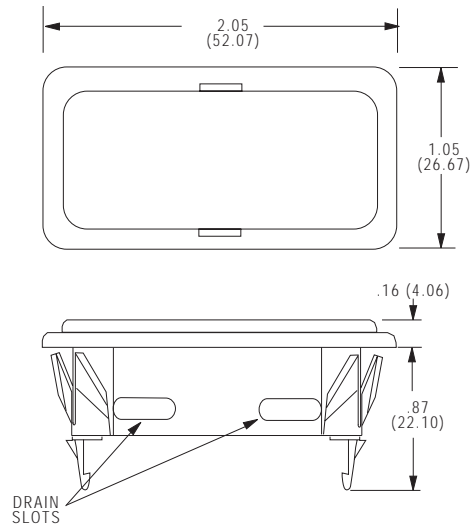

Note: For recommended panel cutout dimensions, see page C7.

"ILLUMINATER™ " SERIES INDICATOR PART NUMBERING SYSTEM

INDICATOR STYLE (See Page C7, Figs. 1&2)

Code	Style
1	Lens Top or Left
2	Lens Bottom or Right
3	Two Lenses

ICON (Location - Top or Left "only") (See Page C8 for Icon Selection Table)

Code	Function
DF	Oil
(Code "ZZ" = No Icon)	

ICON (Location - Bottom or Right "only") (See Page C8 for Icon Selection Table)

Code	Function
BF	Horn
(Code "ZZ" = No Icon)	

MOUNTING POSITION/ COLOR

Code	Color
D	Horizontal/ Black
E	Vertical/ Black

DIFFUSION LENS COLOR (Location - Top or Left "only")

Code	Color
0	None
1	Amber
2	Blue
3	Green
4	Red
5	White
6	Clear

DIFFUSION LENS COLOR (Location - Bottom or Right "only")

Code	Color
0	None
1	Amber
2	Blue
3	Green
4	Red
5	White
6	Clear

ROO B 5 J D 3 DF 2 ZZ 3 Y = ROOB5JD3DF2ZZ3Y

INDICATOR SUPERSTRUCTURE

BEZEL COLOR

Code	Color
B	Black

BEZEL STYLE

Code	Style
5	

LAMP SELECTION

Code	Voltage	No. Lamps	Location
D	14VDC	1	Top or Left
E	14VDC	1	Bottom or Right
F	14VDC	2	Both Locations
G	28VDC	1	Top or Left
H	28VDC	1	Bottom or Right
J	28VDC	2	Both Locations
K	SeeⓄ	1	Top or Left
L	SeeⓄ	1	Bottom or Right
M	SeeⓄ	2	Both Locations

Ⓞ Furnished without lamps. Provisions for lamp available as indicated under location.

PART NUMBER WORKSHEET

Indicator Superstructure	Bezel Color	Bezel Style	Lamp Selection	Mounting Position	Indicator Style	Icon - Top or Left	Diff. Lens Color	Icon - Bot. or Right	Diff. Lens Color	Lamp Selection
ROO	B	5	J	K	3	DF	2	ZZ	3	Y
ROO										Y
ROO										Y
ROO										Y

ACCESSORY ITEM

INDICATOR STYLE

RECOMMENDED PANEL CUTOUT

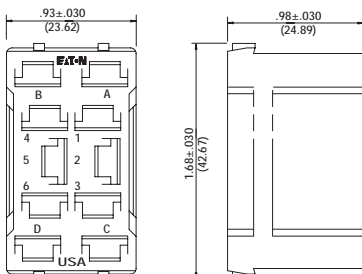

Connector Shell P/N 17-19388.

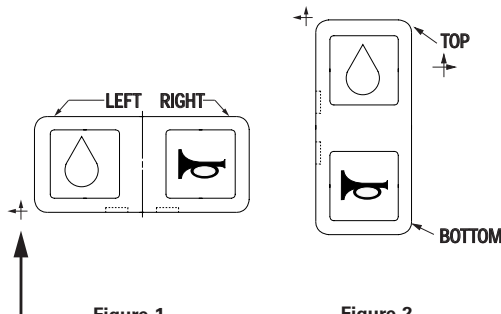
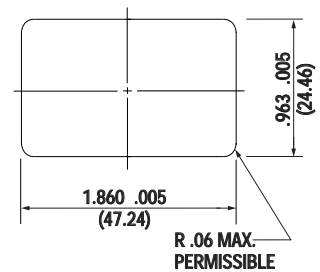

Figure 1 Horizontal Mount.

Figure 2 Vertical Mount

Mounting orientation shown on bottom of base designates top or left indicator light mounting direction.

DIMENSIONS AND PANEL THICKNESS



Recommended Metal Panel Thickness .040 (1.02) to .140 (3.56)

"ILLUMINATER™ " SERIES ICON SELECTION TABLE

Code		Description	SAE Spec. No. J1632	Code		Description	SAE Spec. No. J1632
-DF		Oil	1056	-AX		Headlights - High/Upper Beam	0082
-CW		Level Indicator	0159	-AY		Headlights - Low/Dipped Beam	0083
-DG		Temperature	0034	-AZ		Work Light	1204
-DA		On/Start	5007	-DK		Parking Lights	0240
-DB		Off/Stop	5008	-CJ		Hazard Warning Lights	0085
-BF		Horn	0244	-BB		Interior Dome Light	1421
-BT		Fast	None	-BC		Beacon	1141
-BV		Slow	None	-DL		Turn Signals	0084
-CN		Lock	1656	-DM		Front Fog Lights	0633
-CR		Unlock	None	-CE		Rear Fog Lights	0634
-DH		Rearward Moving Machine Alarm	None	-BA		Instrument Illumination	1556
-DJ		Rearward Moving Machine Alarm-CANCEL	None	-BG		Windshield-Wiper	0086
-BU		Engine-Basic Symbol	1156	-BH		Windshield Washer	0088
-CK		Engine-Electrical Preheat (Low Temperature Start Aid)	1704	-CU		Windshield - Washer & Wiper	0087
-AJ		Engine-Gas Injection (Low Temperature Start Aid)	1547	-BJ		Rear Window - Wiper	0097
-BZ		Transmission-Basic Symbol	1166	-BK		Rear Window - Washer	0099
-BL		Fuel or Fuel System Basic Symbol	0245	-DN		Rear Window - Washer & Wiper	0098
				-AA		Heater/Interior Heating	0637
				-BE		Air Conditioning/Cooling System	0027
				-BD		Ventilating/Air Circulating Fan	0089

Typical icons illustrated are per SAE Pub No.s: J-107, J-1048, and J-1449. Additional icons are available upon request.
Note: If no icon is required, enter cod "ZZ".

ECONOSWITCH SEALED ROCKER SWITCHES

Series - 8551, 8552, 8553

Econoswitch Sealed Rocker Switches With Removable Rocker Button (RB Series)

FEATURES		SPECIFICATIONS		CURRENT RATINGS					
<ul style="list-style-type: none"> Environmentally sealed 1, 2 and 4 pole circuitry 2 & 3 position with maintained and momentary action Rocker button is removable for decal or icon interchangeability Multi-circuits Three types of termination offered as standard Rocker button variations <ul style="list-style-type: none"> Smooth and serrated in opaque colors Transparent Translucent Panel mounting variations <ul style="list-style-type: none"> Flush panel Sub panel 	<ul style="list-style-type: none"> Watertight per MIL-STD-108E and designed to meet IP68 UL recognized and CSA certified Patented base compression seal Temperature Range: -50°F to +150°F (-46°C to +66 °) Life: 50,000 operations at rated load 100,00 operations mechanical life Three standard types of terminals <ul style="list-style-type: none"> Screw 6-32" UNC-2A Solder lug .125 [3,17] dia. hole Spade .250 [6,35]x.032 [0,81] thick 	28VDC			115 VAC 60 or 400Hz				
		No. of Poles	Catalog Number	Type of Operation	Resistive Load	Inductive Load	Lamp Load	Resistive Load	Inductive Load
1	8551	Maintained Momentary	20 15	15 10	5 4	15 11	10 7	3 2	
2	8552	Maintained Momentary	20 18	15 10	7 5	15 11	15 8	4 2	
4	8553	Maintained Momentary	20 18	12 10	5 4	15 11	15 8	4 2	

Note: See page C28 for UL and CSA current ratings.

WHEN ORDERING SPECIFY

* Catalog number of base switch followed by suffix letters and numbers for mounting bracket, rocker color and style as listed in selection table.

Order Example:

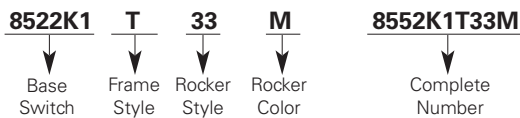

Sub-Panel Style



Flush Panel Style

SELECTION TABLE

CIRCUIT WITH LEVER IN . . .			BASE CATALOG NUMBER ^②			SUFFIX NUMBERS & LETTERS - ADD TO BASE CATALOG NUMBER					
Up Position	Center Position	Down Position (ID lug) ^①	Screw Terminals	Solder Terminals	Spade Terminals	MOUNTING BRACKET		ROCKER STYLE ^③		ROCKER COLOR	
						Frame Style	Code Letter	Style	Code No.	Color	Code Letter
One Pole											
ON	OFF	ON	8551K1	8551K91	8551K31						
ON	NONE	OFF	K9	K99	K39					White	M
ON	NONE	ON	K4	K94	K34						
ON	OFF	NONE	K6	K96	K36						
ON	OFF*	NONE	K8	K98	K38						
ON	NONE	ON*	K5	K95	K35						
* ON	OFF	ON*	K2	K92	K32						
NONE	OFF	ON*	K7	K97	K37						
ON	NONE	OFF*	K10	K910	K310	Flush Panel	T	Serrated	32	Red	T
OFF	NONE	ON*	K11	K911	K311						
ON	OFF	ON*	K3	K93	K33						
* ON	ON	NONE	K12	K912	K312						
ON	ON	NONE	K13	K913	K313						
Two Pole											
ON	OFF	ON	8552K1	8552K91	8552K31					Black	V
ON	NONE	OFF	K9	K99	K39						
ON	NONE	ON	K4	K94	K34						
ON	OFF	NONE	K6	K96	K36						
ON	OFF*	NONE	K8	K98	K38						
ON	NONE	ON*	K5	K95	K35						
* ON	OFF	ON*	K2	K92	K32	Sub-Panel	W	Smooth	33	Translucent	L
NONE	OFF	ON*	K7	K97	K37						
ON	NONE	OFF*	K10	K910	K310						
OFF	NONE	ON*	K11	K911	K311						
ON	OFF	ON*	K3	K93	K33						
* ON	ON	NONE	K12	K912	K312					Transparent	P
ON	ON	NONE	K13	K913	K313						
ON	ON	ON	K14	K914	K314						
ON	ON	ON*	K15	K915	K315						
* ON	ON	ON*	K16	K916	K316						

* Momentary Contact.

① Identification lug side.

② Incomplete catalog number: add suffix letters and numbers for Mounting Brackets, Rocker Style & Color

③ Other Rocker Styles available

ECONOSWITCH SEALED ROCKER SWITCHES

Series - 8551, 8552, 8553

Econoswitch Sealed Rocker Switches With Removable Rocker Button (RB Series)

SELECTION TABLE, CONT.

CIRCUIT WITH LEVER IN . . .			BASE CATALOG NUMBER ^②			SUFFIX NUMBERS & LETTERS - ADD TO BASE CATALOG NUMBER					
Up Position	Center Position	Down Position (ID lug) ^①	Screw Terminals	Solder Terminals	Spade Terminals	MOUNTING BRACKET		ROCKER STYLE ^③		ROCKER COLOR	
						Frame Style	Code Letter	Style	Code No.	Color	Code Letter
Four Pole											
ON	OFF	ON	8553K1	8553K91	8553K31					White	M
ON	NONE	OFF	K9	K99	K39						
ON	NONE	ON	K4	K94	K34						
ON	OFF	NONE	K6	K96	K36	Flush Panel	T	Serrated	32	Red	T
ON	OFF*	NONE	K8	K98	K38						
ON	NONE	ON*	K5	K95	K35						
* ON	OFF	ON*	K2	K92	K32					Black	V
NONE	OFF	ON*	K7	K97	K37						
ON	NONE	OFF*	K10	K910	K310						
OFF	NONE	ON*	K11	K911	K311						
ON	OFF	ON*	K3	K93	K33						
* ON	ON	NONE	K12	K912	K312	Sub-Panel	W	Smooth	33	Translucent	L
ON	ON	NONE	K13	K913	K313						
ON	ON	ON	K15	K915	K315						
ON	ON	ON*	K16	K916	K316						
* ON	ON	ON*	K17	K917	K317					Transparent	P

*** Momentary circuit.**

See pages C26-C27 and C29-C31 for circuit diagrams.

① Identification lug side.

② Incomplete catalog number: add suffix letters and numbers for Mounting Brackets, Rocker Style & Color

③ Other Rocker Styles available

MOUNTING DIMENSIONS - ONE POLE / 8551

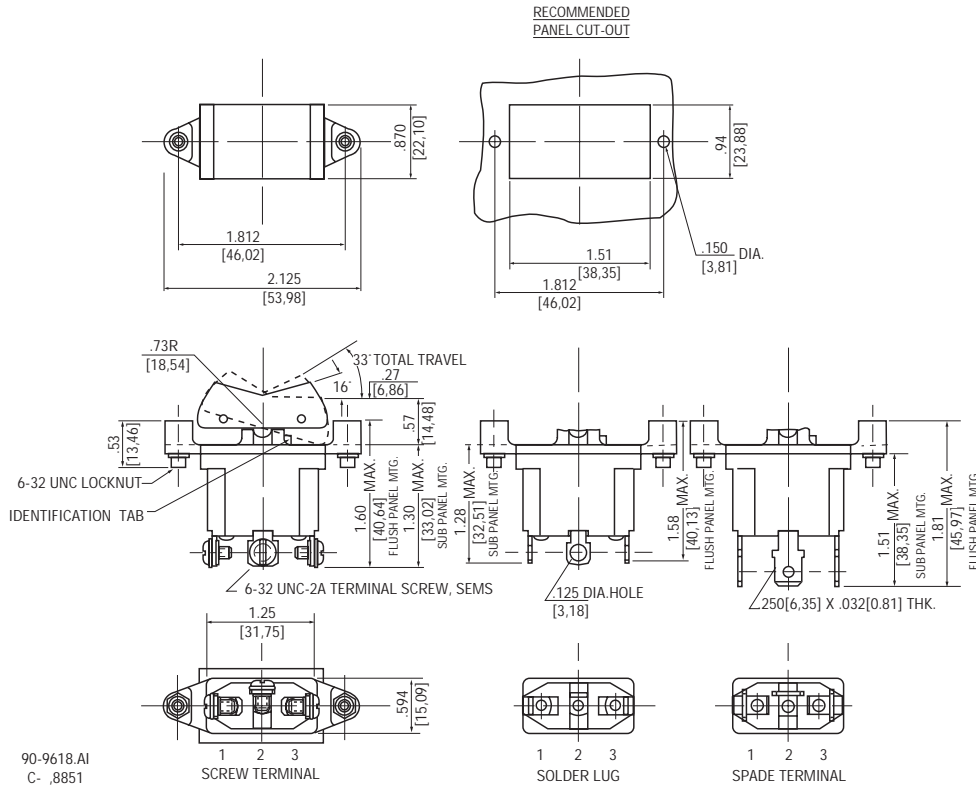

90-9618.AI
C-8851

STANDARD

0.00 = inches

[0,0] = mm

Dimensions for reference only.

MOUNTING DIMENSIONS - TWO POLE / 8552

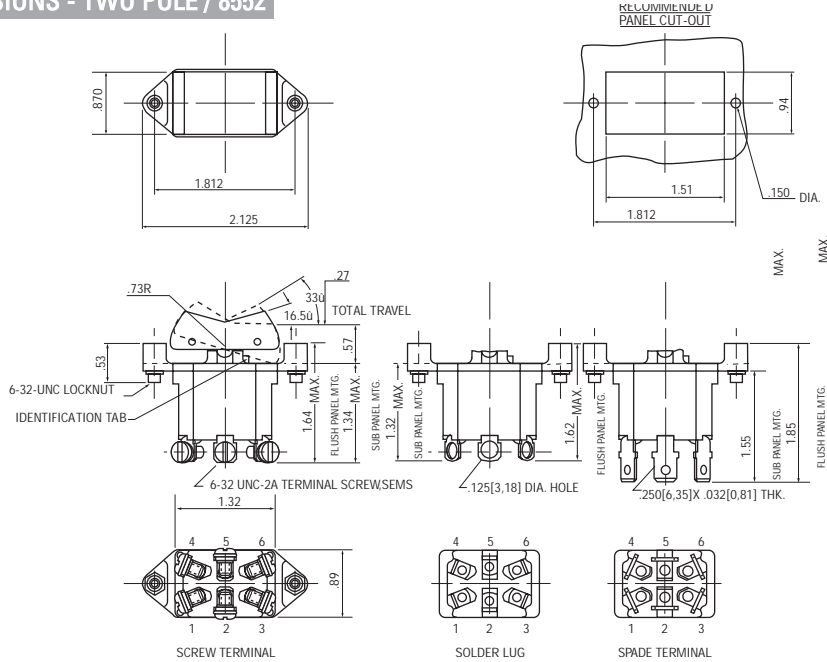

MOUNTING DIMENSIONS - FOUR POLE / 8553

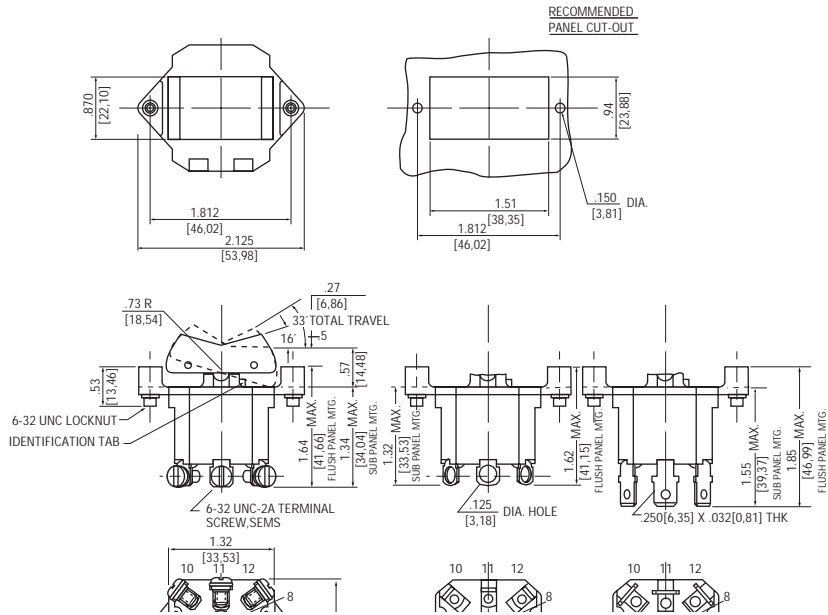

STANDARD
0.00 = inches
[0,0] = mm

Dimensions for reference only.

ECONOSWITCH SEALED ROCKER SWITCHES

Series - 8551, 8552, 8553

Econoswitch Sealed Rocker Switches With Removable Rocker Button (RB Series)

OPTIONS/ACCESSORIES

- Special color rockers
- Hot stamped lettering on rockers - smooth rockers only
- Special marking on switches
- Optional Actuator
- Gold plated contacts

REPLACEMENT SMOOTH BUTTON SELECTION TABLE

Color	Part Number
White	53-2161-2
Red	53-2161-3
Black	53-2161-4
Translucent	53-2415
Transparent	53-2161-6

FEATURES		SPECIFICATIONS		CURRENT RATINGS									
<ul style="list-style-type: none"> Environmentally sealed 1, 2 and 4 pole circuitry 2 & 3 position with maintained and momentary action Pinned rocker button Rocker button style and color variations Multi-circuits Thermoplastic rocker buttons in opaque colors (serrated and smooth face) Panel mounting variations <ul style="list-style-type: none"> Flush panel Sub-panel Snap-in 	<ul style="list-style-type: none"> Watertight per MIL-STD-108E and designed to meet IP68 UL recognized and CSA certified Temperature range: -50°F to +150°F (-46°C to +66°C) Life: 50,000 operations at rated load 100,000 operations mechanical life Three standard types of terminals <ul style="list-style-type: none"> Screw 6-32 UNC-2A Solder lug .125 [3,17] dia. hole Spade .250 [6,35] x .032 [0.82] thick 	No. of Poles		Catalog Number		Type of Operation		28VDC			115 VAC 60 or 400Hz		
								Resistive Load	Inductive Load	Lamp Load	Resistive Load	Inductive Load	Lamp Load
		1	8554	Maintained	20	15	5	15	10	3			
				Momentary	15	10	4	11	7	2			
2	8555	Maintained	20	15	7	15	15	4					
		Momentary	18	10	5	11	8	2					
4	8556	Maintained	20	12	5	15	15	4					
		Momentary	18	10	4	11	8	2					

Note: See page C28 for UL and CSA current ratings.

WHEN ORDERING SPECIFY . . .

• Catalog number of base switch followed by suffix letters and numbers for mounting bracket, rocker color and style as listed in selection table.

Order Example:

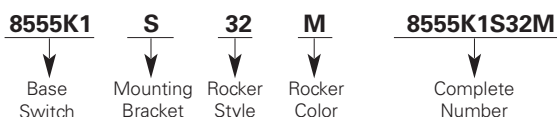

One Pole
Snap-in Bezel
Mounting



Two Pole
Flush Panel
Mounting



Four Pole
Sub-Panel
Mounting

SELECTION TABLE

CIRCUIT WITH LEVER IN . . .			BASE CATALOG NUMBER@			SUFFIX NUMBERS & LETTERS - ADD TO BASE CATALOG NUMBER						
Up Position	Center Position	Down Position (Keyway)				MOUNTING BRACKET			ROCKER STYLE		ROCKER COLOR	
			Screw Terminals	Solder Terminals	Spade Terminals	Frame Style	Mounting Holes	Code Letter	Style	Code No.	Color	Code Letter
One Pole												
ON	OFF	ON	8554K1	8554K91	8554K31	Sub-Panel Mounting-Clearance Holes	0.152	R				
ON	NONE	OFF	K9	K99	K39							
ON	NONE	ON	K4	K94	K34							
ON	OFF	NONE	K6	K96	K36							
ON	OFF*	NONE	K8	K98	K38							
ON	NONE	ON*	K5	K95	K35							
* ON	OFF	ON*	K2	K92	K32							
NONE	OFF	ON*	K7	K97	K37							
ON	NONE	OFF*	K10	K910	K310							
OFF	NONE	ON*	K11	K911	K311							
ON	OFF	ON*	K3	K93	K33							
* ON	ON	NONE	K12	K912	K312							
ON	ON	NONE	K13	K913	K313							
Two Pole												
ON	OFF	ON	8555K1	8555K91	8555K31	Sub-Panel Mounting-Tapped Holes	6-32 UNC-2B	W	Serrated	32	White	M
ON	NONE	OFF	K9	K99	K39							
ON	NONE	ON	K4	K94	K34							
ON	OFF	NONE	K6	K96	K36							
ON	OFF*	NONE	K8	K98	K38							
ON	NONE	ON*	K5	K95	K35							
* ON	OFF	ON*	K2	K92	K32							
NONE	OFF	ON*	K7	K97	K37							
ON	NONE	OFF*	K10	K910	K310							
OFF	NONE	ON*	K11	K911	K311							
ON	OFF	ON*	K3	K93	K33							
* ON	ON	NONE	K12	K912	K312							
ON	ON	NONE	K13	K913	K313							
ON	ON	ON	K14	K914	K314							
ON	ON	ON*	K15	K915	K315							
* ON	ON	ON*	K16	K916	K316							
Snap-in Bezel Mounting — X												



* Momentary Contact.

ECONOSWITCH SEALED ROCKER SWITCHES

Series - 8554, 8555, 8556

Econoswitch Sealed Rocker Switches

SELECTION TABLE

CIRCUIT WITH LEVER IN . . .			BASE CATALOG NUMBER [Ⓞ]			SUFFIX NUMBERS & LETTERS - ADD TO BASE CATALOG NUMBER						
Up Position	Center Position	Down Position (Keyway)	Screw Terminals	Solder Terminals	Spade Terminals	MOUNTING BRACKET			ROCKER STYLE		ROCKER COLOR	
						Style	Mounting Holes	Code Letter	Style	Code No.	Color	Code Letter
Four Pole												
ON	OFF	ON	8556K1	8556K91	8556K31	Sub-Panel						
ON	NONE	OFF	K9	K99	K39	Mounting-	0.152	R				
ON	NONE	ON	K4	K94	K34	Clearance						
ON	OFF	NONE	K6	K96	K36	Holes					White	M
ON	OFF*	NONE	K8	K98	K38							
ON	NONE	ON*	K5	K95	K35	Sub-Panel						
* ON	OFF	ON*	K2	K92	K32	Mounting-	6-32	W	Serrated	32		
NONE	OFF	ON*	K7	K97	K37	Tapped Holes	UNC-2B					
ON	NONE	OFF*	K10	K910	K310							
OFF	NONE	ON*	K11	K911	K311	Flush Panel						
ON	OFF	ON*	K3	K93	K33	Mounting-					Black	V
* ON	ON	NONE	K12	K912	K312	Clearance	0.152					
ON	ON	NONE	K13	K913	K313	Holes		S				
ON	ON	ON	K15	K915	K315							
ON	ON	ON*	K16	K916	K316	Flush Panel			Smooth	33		
* ON	ON	ON*	K17	K917	K317	Mounting-	6-32	T			Red	T
						Tapped Holes	UNC-2B					
						Snap-in Bezel						
						Mounting	--	X				

* Momentary contact.

See pages C26-C27 and C29-C31 for circuit diagrams.

Ⓞ Incomplete Catalog Number - add suffix letters and numbers for Mounting Bracket, Rocker Style and Rocker Color - see "When Ordering Specify."

STANDARD

0.00 = inches

[0,0] = mm

Dimensions for reference only.

MOUNTING DIMENSIONS - ONE POLE / 8554

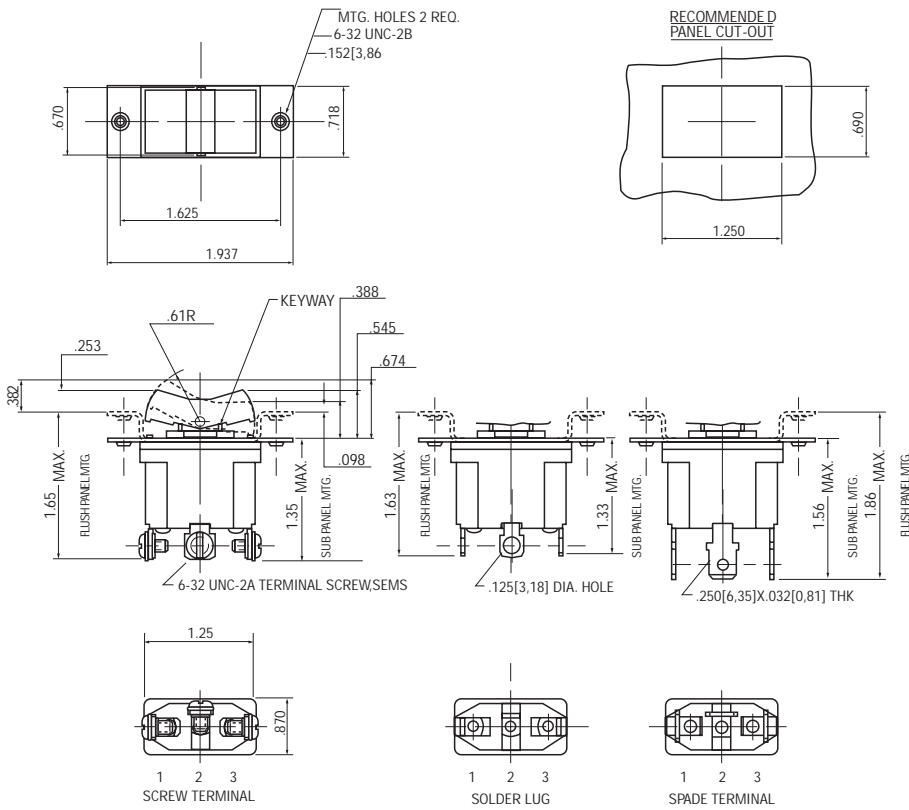

MOUNTING DIMENSIONS - SNAP-IN BEZEL ONE POLE / 8554

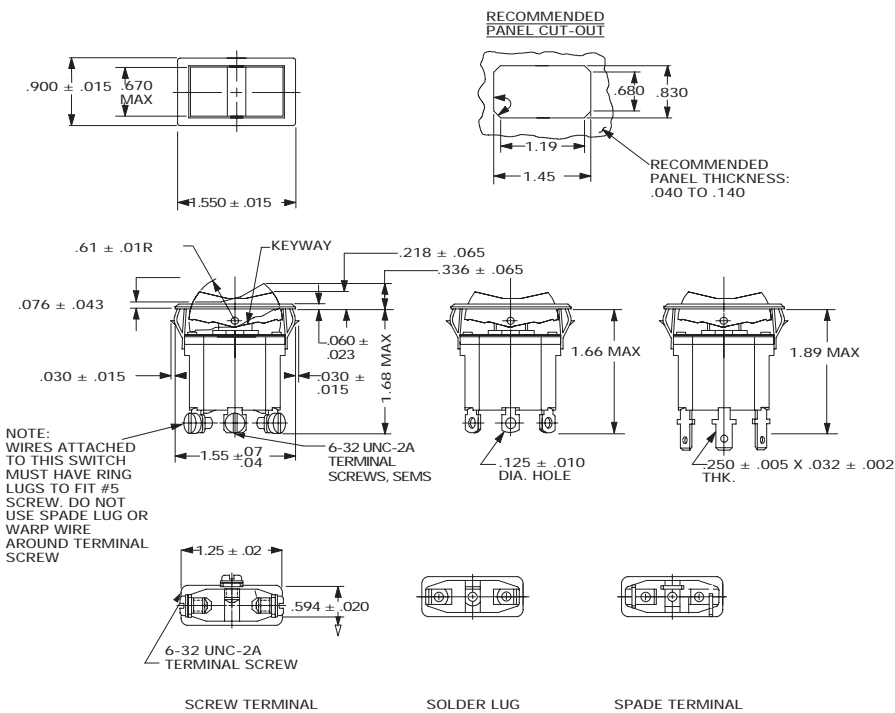

ECONOSWITCH SEALED ROCKER SWITCHES

Series - 8554, 8555, 8556

Econoswitch Sealed Rocker Switches

MOUNTING DIMENSIONS - TWO POLE / 8555

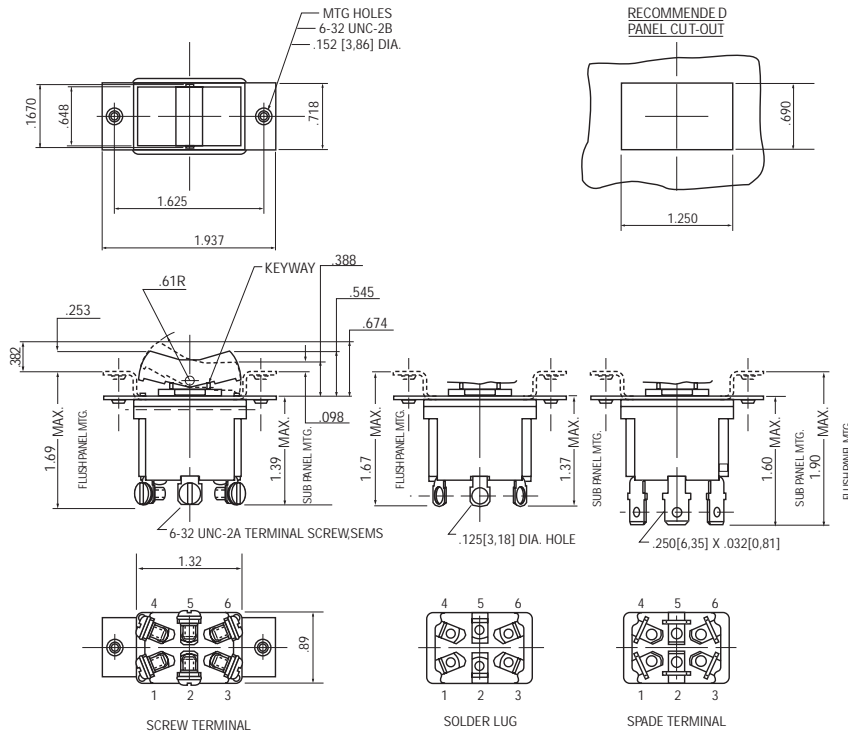

MOUNTING DIMENSIONS - SNAP-IN BEZEL TWO POLE / 8555

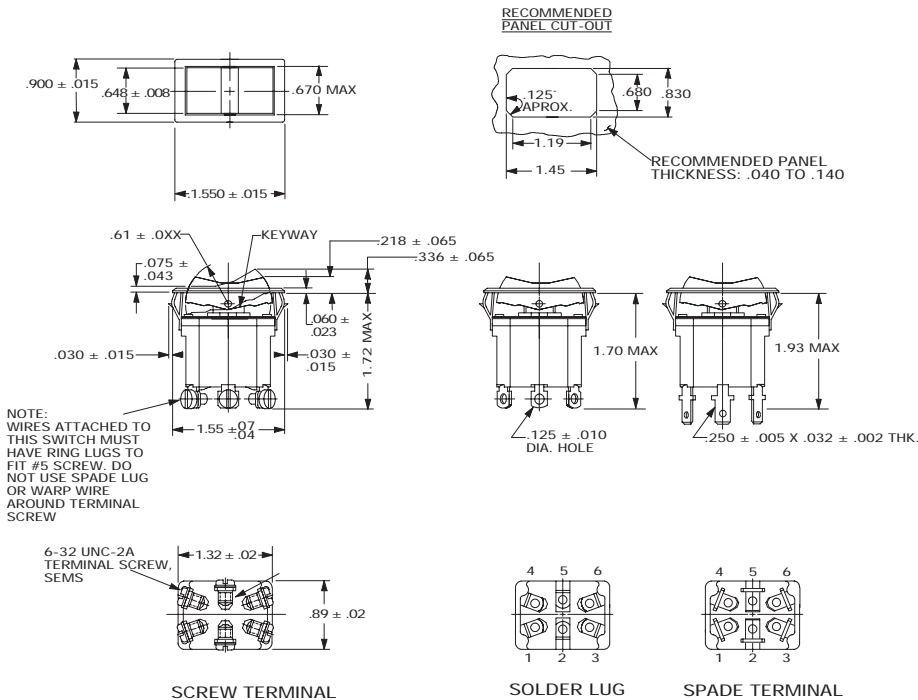

STANDARD

0.00 = inches

[0,0] = mm

Dimensions for reference only.

ECONOSWITCH SEALED ROCKER SWITCHES

Series - 8554, 8555, 8556

Econoswitch Sealed Rocker Switches

MOUNTING DIMENSIONS - FOUR POLE / 8556

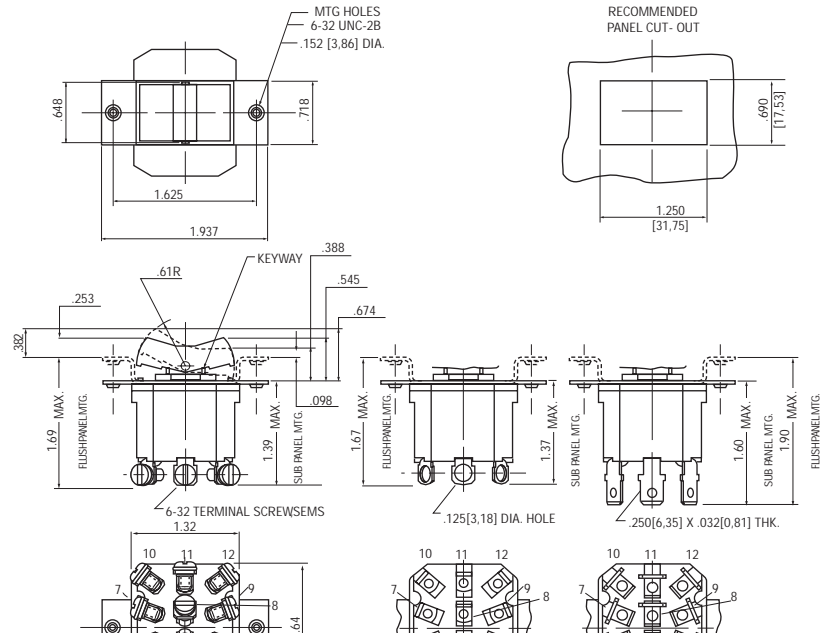

MOUNTING DIMENSIONS - SNAP-IN BEZEL FOUR POLE / 8556

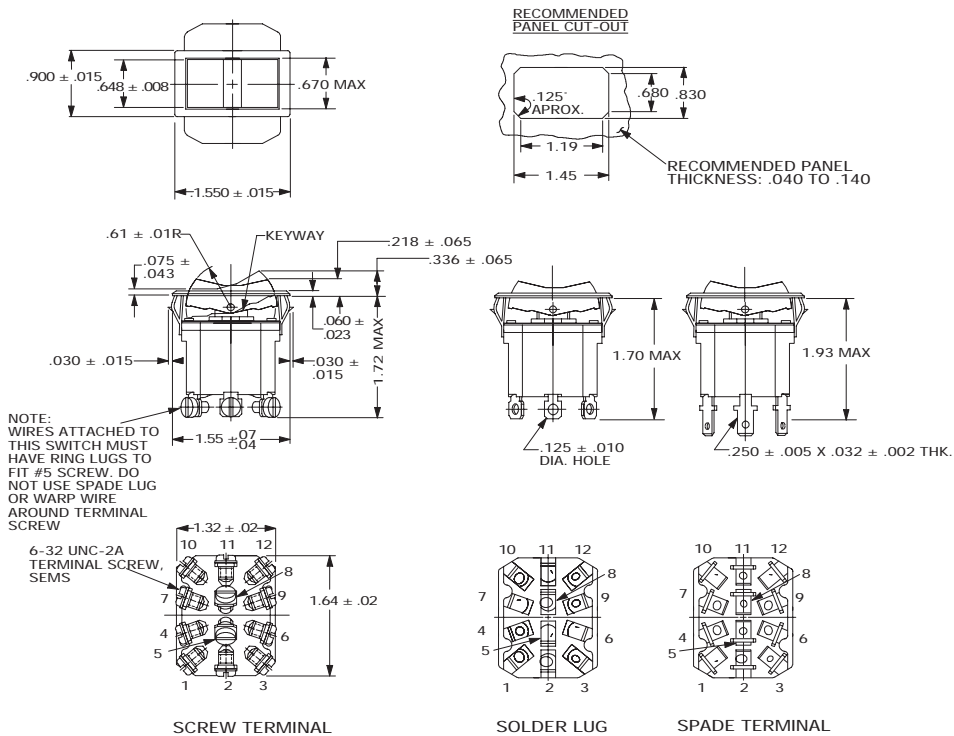

STANDARD

0.00 = inches

[0,0] = mm

Dimensions for reference only.

OPTIONS/ACCESSORIES

- Special color rockers
- Hot stamped lettering on rockers - smooth rockers only
- Special plated bezels
- Special marking on switches
- Optional Actuator
- Gold plated contacts

ENVIRONMENTALLY SEALED ROCKER SWITCHES

Series - 8540, 8541, 8542

Environmentally Sealed Rocker Switches

FEATURES	SPECIFICATIONS	CURRENT RATINGS								
		No. of Poles	Catalog Number	Type of Operation	28VDC			115 VAC 60 or 400Hz		
<ul style="list-style-type: none"> Environmentally sealed 1, 2 and 4 pole circuitry 2 & 3 position with maintained and momentary action Pinned rocker button Multi-circuits Molded-in terminal inserts and terminal numbers Panel mounting variations <ul style="list-style-type: none"> Flush panel Sub-panel Snap-in Thermoplastic rocker buttons in opaque colors (serrated and smooth face) 	<ul style="list-style-type: none"> Watertight per MIL-STD-108E and designed to meet IP68 UL recognized and CSA certified Temperature range: -50°F to +150°F (-46°C to +66°C) Life: 20,000 operations at rated load 40,000 operations mechanical life 				Resistive Load	Inductive Load	Lamp Load	Resistive Load	Inductive Load	Lamp Load
		1	8540	Maintained	20	15	5	15	10	3
				Momentary	15	10	4	15	7	2
		2	8541	Maintained	20	15	7	15	15	4
		Momentary	18	10	5	11	8	2		
4	8542	Maintained	20	12	5	15	15	4		
		Momentary	18	10	4	11	8	2		

Note: See page C28 for UL and CSA current ratings.

WHEN ORDERING SPECIFY . . .

- Catalog number of base switch followed by suffix letters and numbers for mounting bracket, rocker color and style as listed in selection table.

Order Example:

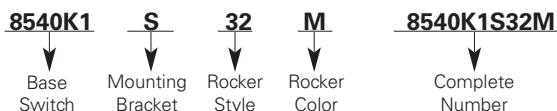

**One Pole
Snap-in Bezel
Mounting**



**Two Pole
Flush Panel
Mounting**



**Four Pole
Sub-Panel
Mounting**

SELECTION TABLE

CIRCUIT WITH LEVER IN . . .			BASE CATALOG NUMBER®			SUFFIX NUMBERS & LETTERS - ADD TO BASE CATALOG NUMBER						
Up Position	Center Position	Down Position (Keyway)	Single Pole	Two Pole	Four Pole	MOUNTING BRACKET			ROCKER STYLE		ROCKER COLOR	
						Style	Mounting Holes	Code Letter	Style	Code No.	Color	Code Letter
ON	OFF	ON	8540K1	8541K1	8542K1	Sub-panel						
ON	NONE	OFF	K9	K9	K9	Mounting-	0.152	R				
ON	NONE	ON	K4	K4	K4	Clear Holes	[3,86]				White	M
ON	OFF	NONE	K6	K6	K6							
ON	OFF*	NONE	K8	K8	K8	Sub-panel	6-32					
ON	NONE	ON*	K5	K5	K5	Mounting-	UNC-2B	W	Serrated	32		
* ON	OFF	ON*	K2	K2	K2	Tapped Holes						
NONE	OFF	ON*	K7	K7	K7	Flush panel					Black	V
ON	NONE	OFF*	K10	K10	K10	Mounting-	0.152	S				
OFF	NONE	ON*	K11	K11	K11	Clear Holes	[3,86]					
ON	OFF	ON*	K3	K3	K3	Flush panel			Smooth	33		
* ON	ON	NONE	K12	K12	K12	Mounting-	6-32	T				
ON	ON	NONE	K13	K13	K13	Tapped Holes	UNC-2B				Red	T
ON	ON	ON		K14	K15							
ON	ON	ON*		K15	K16	Snap-in Bezel						
* ON	ON	ON*		K16	K17	Mounting-	—	X				
ON	ON	ON	—	8541K17	—							
ON	ON	ON*	—	K18	—							
* ON	ON	ON*	—	K19	—							

* Momentary contact.

See pages C26-C27 and C29-C31 for circuit diagrams.

® Incomplete Catalog Number - add suffix letters and numbers for Mounting Bracket, Rocker Style and Rocker Color - see "When Ordering Specify."

ENVIRONMENTALLY SEALED ROCKER SWITCHES

Series - 8540, 8541, 8542

Environmentally Sealed Rocker Switches

DIMENSIONS - ONE POLE / 8540

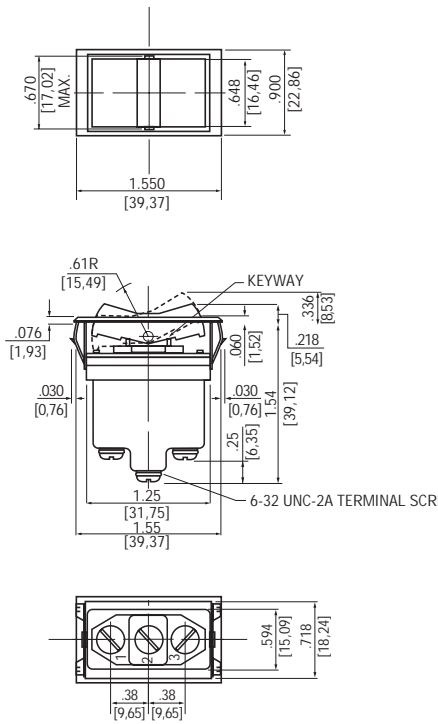

RECOMMENDED PANEL CUT-OUT

SNAP-IN BEZEL MOUNTING
 .040 [1,02] to .140 [3,56] PANEL THICKNESS

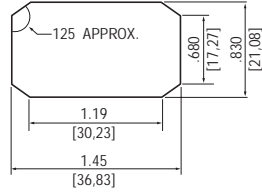

FLUSH AND SUB-PANEL ONLY

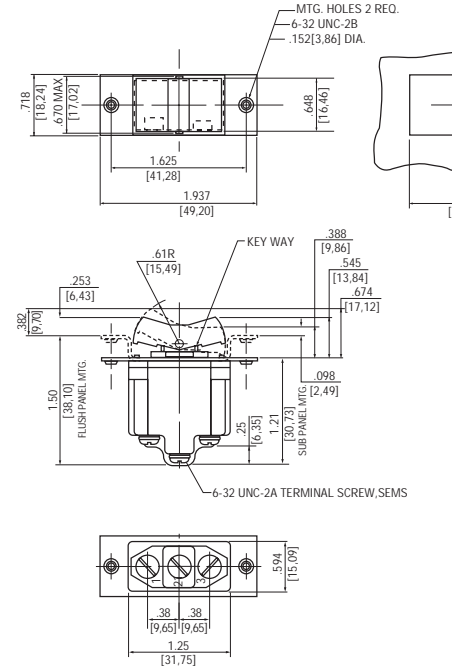
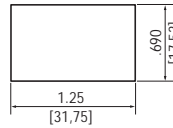

90-5781.A1
 © 2004 EATON

DIMENSIONS - TWO POLE / 8541

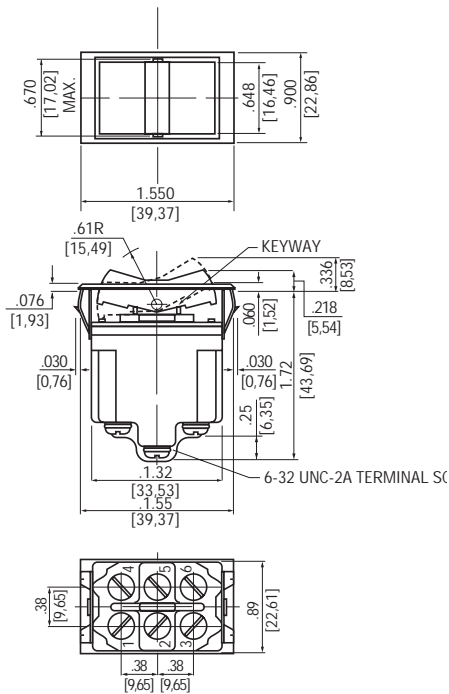

RECOMMENDED PANEL CUT-OUT

SNAP-IN BEZEL MOUNTING
 .040 [1,02] to .140 [3,56] PANEL THICKNESS

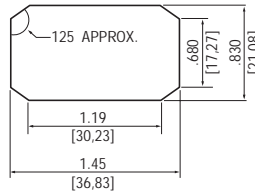

FLUSH AND SUB-PANEL ONLY

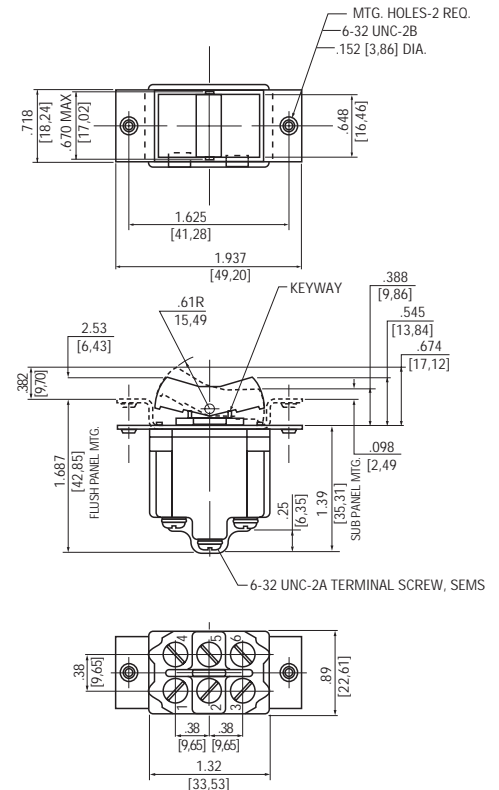
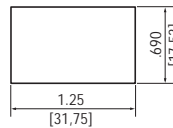

STANDARD

0.00 = inches

[0,0] = mm

Mounting dimensions for reference only.

DIMENSIONS - FOUR POLE / 8542

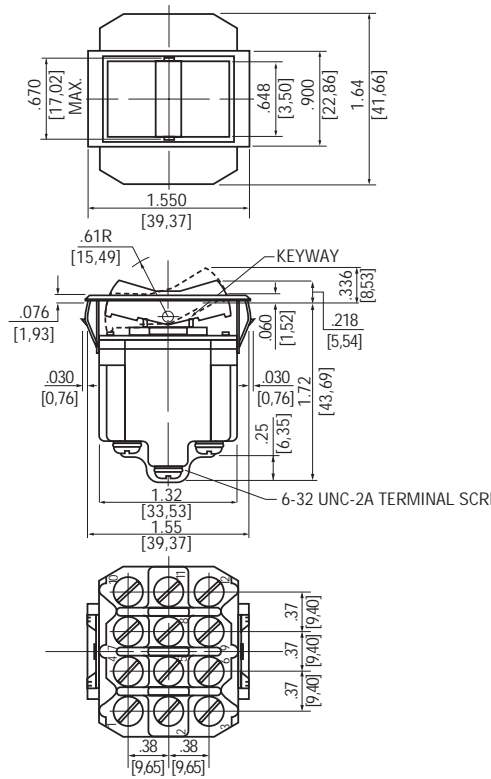

RECOMMENDED PANEL CUT-OUT

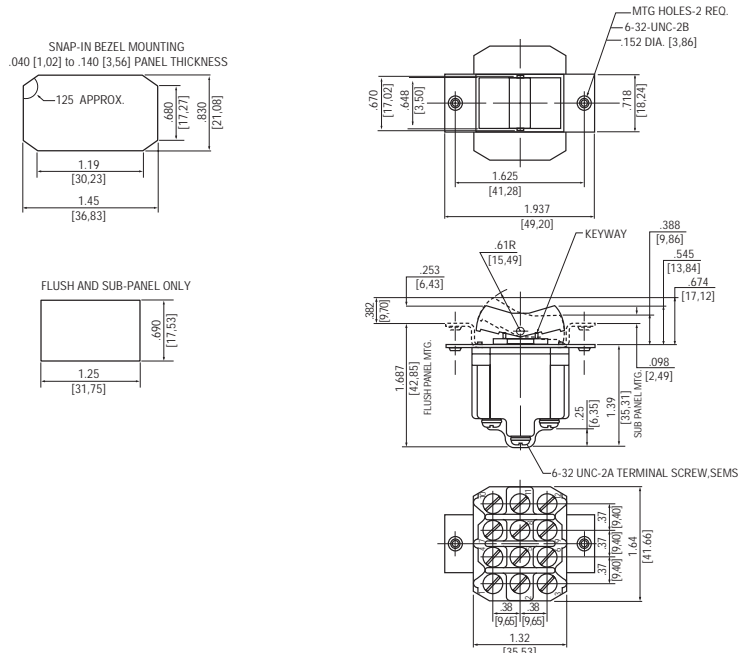

OPTIONS/ACCESSORIES

- Special color rockers
- Hot stamped lettering on rockers - smooth rockers only
- Spade terminals
- Special spade terminal adapters (0.250")
- Special plated bezels
- Special marking on switches
- Optional Actuator
- Additional sealed rocker styles available

STANDARD

0.00 = inches

[0,0] = mm

Mounting dimensions for reference only.

ENVIRONMENTALLY SEALED ROCKER SWITCHES

Series - 8543, 8544, 8545

Environmentally Sealed Rocker Switches
with Removable Button (RB Series)

FEATURES	SPECIFICATIONS	CURRENT RATINGS										
		No. of Poles	Catalog Number	Type of Operation	28VDC			115 VAC 60 or 400Hz				
<ul style="list-style-type: none"> Environmentally sealed 1, 2 and 4 pole circuitry 2 & 3 position with maintained and momentary action Rocker button is removable for decal or icon interchangeability Multi-circuit Panel mounting variations <ul style="list-style-type: none"> Flush panel Sub-panel Rocker button variations <ul style="list-style-type: none"> Smooth and serrated in opaque colors Transparent Translucent 	<ul style="list-style-type: none"> Watertight per MIL-STD-108E and designed to meet IP68 UL recognized and CSA certified Temperature range: -55°F to +150°F (-46°C to +66°C) Life: 20,000 operations at rated load 40,000 operations mechanical life 											
		1	8543	Maintained	Resistive Load	Inductive Load	Lamp Load	Resistive Load	Inductive Load	Lamp Load		
				Momentary	20	15	5	15	10	3		
					15	10	4	15	7	2		
		2	8544	Maintained	20	15	7	15	15	4		
				Momentary	18	10	5	11	8	2		
		4	8545	Maintained	20	12	5	15	15	4		
				Momentary	18	10	4	11	8	2		

NOTE: See page C28 for UL & CSA Ratings

WHEN ORDERING SPECIFY . . .

• Catalog number of base switch followed by suffix letters and numbers for mounting bracket, rocker color and style as listed in selection table.

Order Example:

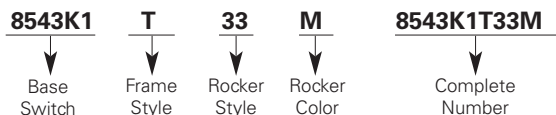

SELECTION TABLE

CIRCUIT WITH LEVER IN . . .			BASE CATALOG NUMBER [ⓐ]			SUFFIX NUMBERS & LETTERS - ADD TO BASE CATALOG NUMBER					
Up Position	Center Position	Down [ⓑ] Position (Keyway)				FRAME STYLE		ROCKER STYLE		ROCKER COLOR	
			Single Pole	Two Pole	Four Pole	Frame Style	Code Letter	Style	Code No.	Color	Code Letter
ON	OFF	ON	8543K1	8544K1	8545K1						
ON	NONE	OFF	K9	K9	K9					White	M
ON	NONE	ON	K4	K4	K4						
ON	OFF	NONE	K6	K6	K6			Serrated	32		
ON	OFF*	NONE	K8	K8	K8						
ON	NONE	ON*	K5	K5	K5	Flush Panel	T			Red	T
* ON	OFF	ON*	K2	K2	K2						
NONE	OFF	ON*	K7	K7	K7						
ON	NONE	OFF*	K10	K10	K10						
OFF	NONE	ON*	K11	K11	K11					Black	V
ON	OFF	ON*	K3	K3	K3						
* ON	ON	NONE	K12	K12	K12			Smooth	33		
ON	ON	NONE	K13	K13	K13						
ON	ON	ON		K14		Sub-Panel				Translucent	L
ON	ON	ON*		K15			W				
* ON	ON	ON*		K16							
ON	ON	ON		K17	K15						
ON	ON	ON*		K18	K16						
* ON	ON	ON*		K19	K17			No Rocker	34	Transparent	P
ON	ON/OFF	ON			K20						
* ON	ON/OFF	ON*			K21						

* Momentary contact.

See pages C26-C27 and C29-C31 for circuit diagrams.

ⓑ Identification lug side.

ⓐ Incomplete Catalog Number - add suffix letters and numbers for Mounting Bracket, Rocker Style and Rocker Color - see "When Ordering Specify."

REPLACEMENT SMOOTH BUTTON SELECTION TABLE

Color	Part Number
White	53-2161-2
Red	53-2161-3
Black	53-2161-4
Translucent	53-2415
Transparent	53-2161-6

ENVIRONMENTALLY SEALED ROCKER SWITCHES

Series - 8543, 8544, 8545

Environmentally Sealed Rocker Switches with Removable Button (RB Series)

DIMENSIONS - ONE POLE / 8543

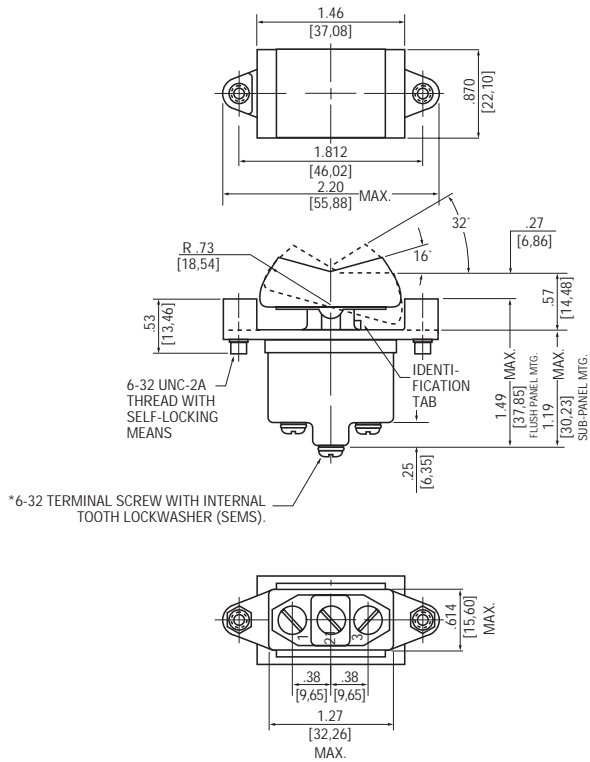

DIMENSIONS - TWO POLE / 8544

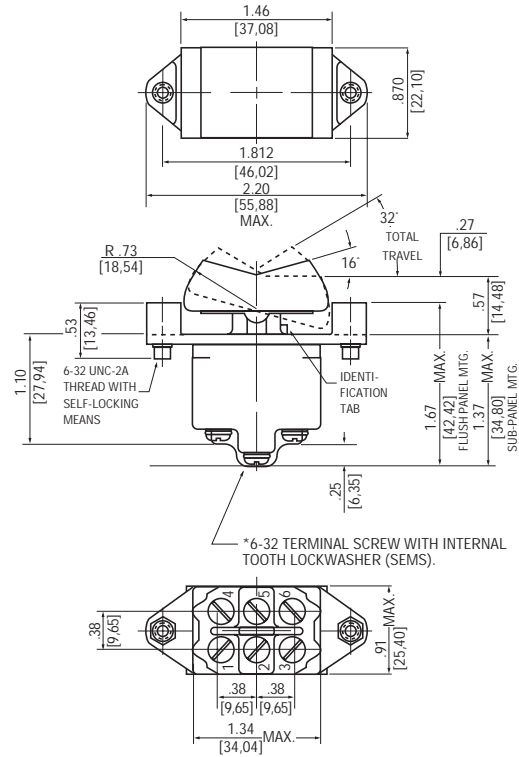

DIMENSIONS - FOUR POLE / 8545

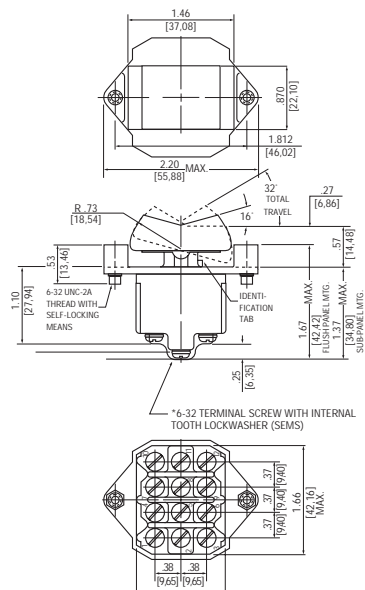

OPTIONS/ACCESSORIES

- Special color rockers
- Hot stamped lettering on rockers - smooth rockers only
- Spade terminals
- Special spade terminal adapters 0.250" [0,63]
- Special marking on switches
- Optional Actuator

RECOMMENDED PANEL CUT-OUT

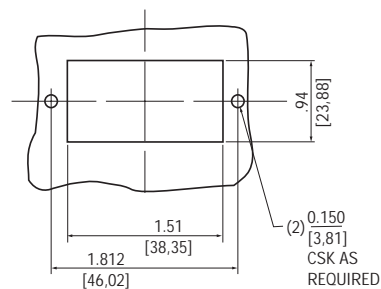

STANDARD

0.00 = inches

[0,0] = mm

Mounting dimensions for reference only.

ENVIRONMENTALLY SEALED ROCKER SWITCHES

Series - 8546, 8547, 8548 MIL-S-3950/14

Environmentally Sealed Rocker Switches

FEATURES SPECIFICATIONS CURRENT RATINGS

- Environmentally sealed
- 1, 2 and 4 pole circuitry
- 2 & 3 position with maintained and momentary action
- Rocker button is removable for decal or icon interchangeability
- Multi-circuit
- Molded-in inserts and terminal numbers
- Panel mounting variations
 - Flush panel
 - Sub-panel
- Rocker button variations
 - Smooth and serrated in opaque colors
 - Transparent
 - Translucent

- MS approved and QPL'd per MIL-S-3950
- Thermoset molding materials meet flame retardant requirements
- Temperature range: -67°F to +160°F (-55°C to +71°C)
- Life: 20,000 operations at rated load
40,000 operations mechanical life

No. of Poles	Catalog Number	Type of Operation	28VDC			115 VAC 60 or 400Hz		
			Resistive Load	Inductive Load	Lamp Load	Resistive Load	Inductive Load	Lamp Load
1	8546	Maintained	20	15	5	15	10	3
		Momentary	15	10	4	15	7	2
2	8547	Maintained	20	15	7	15	15	4
		Momentary	18	10	5	11	8	2
4	8548	Maintained	20	12	5	15	15	4
		Momentary	18	10	4	11	8	2

WHEN ORDERING SPECIFY . . .

- Catalog number of base switch followed by suffix letters and numbers for mounting bracket, rocker color and style as listed in selection table.

Order Example:

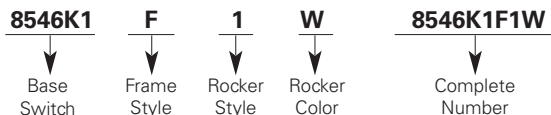

Sub-Panel Mounting



Flush Panel Mounting

SELECTION TABLE

CIRCUIT WITH LEVER IN . . . BASE CATALOG NUMBER[Ⓜ]

Up Position	Center Position	Down [Ⓜ] Position (Keyway)	Single Pole		Double Pole		Four Pole		Frame Style	Code Letter	Rocker Style	Code Letter	Rocker Color	Code Letter
			Eaton [Ⓜ]	M3950/14A [Ⓜ]	Eaton [Ⓜ]	M3950/14B [Ⓜ]	Eaton [Ⓜ]	M3950/14C [Ⓜ]						
ON	OFF	ON	8546K1	M3950/14A21	8547K1	M3950/14B21	8548K1	M3950/14C21						
ON	NONE	OFF	K9	A22	K9	B22	K9	C22						
ON	NONE	ON	K4	A23	K4	B23	K4	C23					White	W
ON	OFF	NONE	K6	A24	K6	B24	K6	C24						
ON	OFF*	NONE	K8	A25	K8	B25	K8	C25						
ON	NONE	ON*	K5	A26	K5	B26	K5	C26	Flush	F	Smooth	1	Red	R
* ON	OFF	ON*	K2	A27	K2	B27	K2	C27						
NONE	OFF	ON*	K7	A28	K7	B28	K7	C28						
ON	NONE	OFF*	K10	A29	K10	B29	K10	C29					Black	B
OFF	NONE	ON*	K11	A30	K11	B30	K11	C30						
ON	OFF	ON*	K3	A31	K3	B31	K3	C31	Sub	S	Serrated	2	Translucent	T
* ON	ON	NONE	K12	A32	K12	B32	K12	C32						
ON	ON	NONE	K13	A33	K13	B33	K13	C33						
ON	ON	ON			K15	B34	K15	C34						
ON	ON	ON*			K16	B35	K16	C35					Transparent	C
* ON	ON	ON*			K17	B36	K17	C36						

*** Momentary Circuit.**

See pages C26-C27 and C29-31 for circuit diagrams.

[Ⓜ] Identification lug side.

[Ⓜ] Incomplete Catalog Number - add suffix letters and numbers for Frame Style, Rocker Style and Rocker Color - see "When Ordering Specify."

[Ⓜ] Incomplete military part number - add suffix codes for Frame Style, Rocker Style and Rocker Color for complete military part number. (i.e. M3950/14A21F1W).

REPLACEMENT BUTTON SELECTION TABLE

Color	Part Number (Smooth Button)
White	53-2161-2
Red	53-2161-3
Black	53-2161-4
Translucent	53-2415
Transparent	53-2161-6

ROCKER SWITCHES - ENVIRONMENTALLY SEALED SWITCHES



Standard Circuit Arrangements

Industrial, Econoswitch and MIL-S-3950 Series

CIRCUIT WITH LEVER IN . . .

Number of Poles and Throws	Switch Circuit ^①	Up Position	Center Position	Down Position (ID Lug)
1PST	ON-NONE-OFF		NONE	OFF
	ON-OFF-NONE		OFF (MOM.)	NONE
	ON-OFF*-NONE		OFF	NONE
	NONE-OFF-ON*		NONE	OFF (MOM.)
	ON-NONE-OFF*		OFF	NONE
	OFF-NONE-ON*		OFF	NONE
1PDT	ON-NONE-ON		NONE	ON
	ON-NONE-ON		NONE	ON
	ON-NONE-ON*		NONE	ON
	ON-OFF-ON		OFF	ON
	ON-OFF-ON*		OFF	ON
	*ON-ON-NONE		ON	NONE
2PST	ON-NONE-OFF		NONE	OFF
	ON-OFF-NONE		OFF	NONE
	ON-OFF*-NONE		OFF (MOM.)	NONE
	NONE-OFF-ON*		OFF	ON
	ON-NONE-OFF*		NONE	OFF (MOM.)
	OFF-NONE-ON*		OFF	ON
2PDT	ON-OFF-ON		ON	ON
	ON-NONE-ON		NONE	ON
	ON-NONE-ON*		NONE	ON
	ON-OFF-ON		ON	ON
	ON-OFF-ON*		ON	ON
	*ON-ON-NONE		ON	NONE
	ON-ON-NONE		ON	NONE
4PST	ON-NONE-OFF		NONE	OFF
	ON-OFF-NONE		OFF	NONE
	ON-OFF*-NONE		OFF (MOM.)	NONE
	NONE-OFF-ON*		OFF	ON
	ON-NONE-OFF*		NONE	OFF (MOM.)
	OFF-NONE-ON*		NONE	ON

CIRCUIT WITH LEVER IN . . . CON'T.

Number of Poles and Throws	Switch Circuit [ⓐ]	Up Position 	Center Position 	Down Position (ID Lug) 
4PDT	ON-OFF-ON		OFF	
	ON-NONE-ON		NONE	
	ON-NONE-ON*		NONE	
	ON-OFF-ON		OFF	
	ON-OFF-ON*		OFF	
	*ON-ON-NONE			NONE
	ON-ON-NONE			NONE
	ON-ON/OFF-ON			
	ON-ON/OFF-ON			

***Momentary contact.**

[ⓐ]See page C29 for ON-ON-ON and special circuits.

NOMINAL RATINGS

Minimum AC Contact Ratings

UL AND CSA NOMINAL RATINGS

Catalog Number	Maximum Horsepower				
	Amperes		1 Phase		3 Phase
	125VAC ^①	250VAC ^①	125VAC ^①	250VAC ^①	125/250VAC ^①
8540K1, 4, 6, 9, 13	18	9	1/4	1/2	—
8540K2, 3, 5, 7, 8, 10-12	18	9	—	—	—
8541K1, 4, 6, 9, 13	18	9	1/2	1	—
8541K2, 3, 5, 7, 8, 10-12, 14-16	18	9	—	—	—
8542K1, 4, 6, 9, 13	18	9	1/2	1	1
8542K2, 3, 5, 7, 8, 10-12, 15-17	18	9	—	—	—
8543K1, 4, 6, 9, 13	18	9	1/4	1/2	—
8543K2, 3, 5, 7, 8, 10-12	18	9	—	—	—
8544K1, 4, 6, 9, 13	18	9	1/2	1	—
8544K2, 3, 5, 7, 8, 10-12, 14-19	18	9	—	—	—
8545K1, 4, 6, 9, 13	18	9	1/2	1	1
8545K2, 3, 5, 7, 8, 10-12, 15-21	18	9	—	—	—
8551K1-13, K31-313, K91-913	18	9	1/4	1/2	—
8552K1-16, K31-316, K91-916	18	9	1/2	1	—
8553K1-17, K31-317, K91-917	18	9	1/2	1	1
8554K1-13, K31-313, K91-913	18	9	1/4	1/2	—
8555K1-16, K31-316, K91-916	18	9	1/2	1	—
8556K1-17, K31-317, K91-917	18	9	1/2	1	1































① 60 Hertz

ROCKER SWITCHES - ENVIRONMENTALLY SEALED SWITCHES

Special ON-ON-ON Circuit Arrangements for Two and Four Pole Switches

Industrial, Econoswitch and MIL-S-3950 Series

CIRCUIT WITH LEVER IN . . .

Number of Poles	Up Position 	Center Position 	Down Position (Keyway) 	Catalog Part Number [ⓐ]
Two Pole				
2	Maintained 	Maintained 	Maintained 	8541K14 8544K14 8547K15 8552K14, 8552K914, 8552K314 8555K14, 8555K914,
2	Maintained 	Maintained 	Momentary 	8541K15 8544K15 8547K16 8552K15, 8552K915, 8552K315 8555K15, 8555K915,
2	Momentary 	Maintained 	Momentary 	8541K16 8544K16 8547K17 8552K16, 8552K916, 8552K316 8555K16, 8555K916, 8555K316
2	Maintained 	Maintained 	Maintained 	8541K17 8544K17 8555K17, 8555K917, 8555K317
2	Maintained 	Maintained 	Momentary 	8541K18 8544K18 8555K18, 8555K918, 8555K318
2	Momentary 	Maintained 	Momentary 	8541K19 8544K19 8555K19, 8555K919, 8555K319
Four Pole				
4	Maintained 	Maintained 	Maintained 	8542K15 8545K15 8548K15 8553K15, 8553K915, 8553K315 8556K15, 8556K915, 8556K315
4	Maintained 	Maintained 	Momentary 	8542K16 8545K16 8548K16 8553K16, 8553K916, 8553K316 8556K16, 8556K916, 8556K316
4	Momentary 	Maintained 	Momentary 	8542K17 8545K17 8548K17 8553K17, 8553K917, 8553K317 8556K17, 8556K917, 8556K317

[ⓐ] Incomplete part number. Basic switch part number referenced only.

ROCKER SWITCHES - ENVIRONMENTALLY SEALED SWITCHES

Special ON-ON-ON Circuit Arrangements for Two and Four Pole Switches Industrial, Econoswitch and MIL-S-3950 Series

CIRCUIT WITH LEVER IN . . .

Number of Poles	Up Position	Center Position	Down Position (Keyway)	Catalog Part Number ^①
Four Pole (Continued)				
4	Maintained 	Maintained 	Maintained 	8545K20
4	Momentary 	Maintained 	Momentary 	8545K21

^① Incomplete part number. Basic switch part number referenced only.

ROCKER SWITCHES - ENVIRONMENTALLY SEALED SWITCHES

Special Circuit Arrangements for Two and Four Pole Switches Industrial, Econoswitch and MIL-S-3950 Series

SPECIAL "ON-ON-ON" CIRCUIT ARRANGEMENTS

"Three Independent" ON-ON-ON Circuit Diagram
For switch modified with "Three Independent" ON-ON-ON Special Circuit.
External Jumpers are required. User to connect wiring per instructions given below.

Connection Points	Single Pole	Double Pole
Connect Common to Terminals	2	2 and 11
Connect Circuit "A" to Terminals	6	6 and 9
Connect Circuit "B" to Terminals	4	4 and 7
Connect Circuit "C" to Terminals	1	1 and 10

Circuit Poles	No. of Poles	Up Position	Center Maintained Position	Down Position (Keyway)
Circuit for Single Pole (Jumper between Terminals #3 & #5)	1			
Circuit for Double Pole (Jumpers between Terminals #3 & #5 #8 & #12)	2			

Note: Basic circuit same as offered with part numbers 8551K14, 8551K15 or 8551K16 for two pole devices and part numbers 8553K15, 8553K16 or 8553K17 for four pole devices.

SPECIAL CIRCUIT (OFF 1- ON - 2 ON)

Circuit	No. of Poles	OFF Up Position	ON Center Maintained Position	ON Down Position (Keyway)	Circuit Being Made ...	Terminal Numbers Making the Circuit
Note: Requires two poles to achieve a single pole device or four poles to achieve a double pole device.						
Circuit for Single Pole (Jumper between terminals #2 & #4). Common terminal #5. Non-functional terminal #6	2	(ON) 	(ON) 	(OFF) 	UP(OFF) CENTER (ON) DOWN (ON)	— #3 & #5 #1 & #5
Circuit for Double Pole (Jumpers between terminals #2 & #4 and #7 & #11). Common terminals #5 & #8. Non-functional terminals #6 & #9	4	(ON) 	(ON) 	(OFF) 	UP(OFF) CENTER (ON) DOWN (ON)	— #3 & #5 #8 & #12 #1 & #5 #8 & #10

SPECIAL PROJECTOR CIRCUIT (OFF - 1 ON - 2 ON)

Circuit	No. of Poles	OFF Up Position	ON Center Maintained Position	ON Down Position (Keyway)	Circuit Being Made ...	Terminal Numbers Making the Circuit
Note: Requires two poles to achieve a single pole device or four poles to achieve a double pole device.						
Circuit for Single Pole (Jumper between terminals #2 & #5). Common terminal #5. Non-functional terminal #1 & #4.	2	(ON) 	(ON) 	(OFF) 	UP(ON) CENTER (ON) DOWN (OFF)	#2 & #3 #5 & #6 #5 & #3 —
Circuit for Double Pole (Jumpers between terminals #2 & #5 and #8 & #11). Common terminals #5 & #8. Non-functional terminals #1, #4, #7 & #10.	4	(ON) 	(ON) 	(OFF) 	UP(ON) CENTER (ON) DOWN (OFF)	#5 & #3 #5 & #6 #8 & #12 #8 & #9 #3 & #5 #11 & #12 —

Precision Snap Action Switches Index

Index

D1

**Basic Switches**

D2 - D4

- Ratings up to 40 amperes
- One, two and three pole configurations
- Choice of terminals
- Maintained and momentary circuits
- Snap action contact mechanism
- Dry circuit capabilities

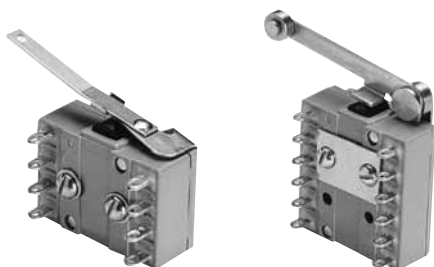
**Roller and Leaf Actuator for Basic Switches**

D5

- Variety of actuator styles
- Actuator metal parts are stainless passivated
- All parts are treated for corrosion resistance
- Adaptable to D and K series switches

**Most items listed in this catalog are standard products and are normally in Distributor Inventory; however, the current inventory status should be checked by contacting your Eaton Customer Service Representative at 800-955-7354 or your authorized Distributor before placing orders.*







BASIC SWITCHES

Precision Snap Action Switches

FEATURES

- Snap action
- Plastic, flame resistant case
- Single, double and three pole circuits
- Eight types of terminations
- Long life
- 1000 V rms dielectric strength
- Current capacities from dry circuit to 40 amperes
- Military approved
- Environmentally sealed
- UL recognized
- Low movement differential and operating force types available
- Stacking and gang mounting capabilities

SELECTION AND SPECIFICATIONS TABLE

SERIES		Characteristics											
	Circuit	Electrical Rating Life	Terminals	Description	Catalog Number	Operating Force (Max.)	Release Force (Min.)	Pretravel (Max.)	Diff. Travel (Min.)	Diff. Travel (Min.)			
	4 CKT Dbl. Brk.	15 amps, 125/250VAC, 30VDC Resistive 10 amps, 30VDC Inductive 100,000 operations mechanical life 50,000 operations electrical life	End Solder Side Solder Side Solder End Solder Side Solder Side Solder	Standard Non-Simultaneous Break MS25348-1 MS25349-1 Reset Type	D4-4 D8-4 D8-9 D4-44 D8-44 D8-344	28+/-5 oz	3 oz.	.060 in.		.018 in.			
Series D													
	1 PDT	Operations, Min. 150,000 2.5 amps. 125/250VAC Res. & Ind. 100,000 5.0 amps. 125/250VAC Res. & Ind. 50,000 4.0 amps. 30VDC Resistive 50,000 2.5 amps. 30VDC Inductive	Solder Double Turret	Standard (Dust, Splash-proof)	E4-103 EM-4111	200 grams	40 grams	.020 in.	.003 in.	.007 in.			
Series E-4 & EM													
	1 PDT	150,000 operations at 2.5 amps, 125/250VAC 100,000 operations at 5.0 amps, 125/250VAC 50,000 operations at 2.5 amps, 30VDC Inductive 50,000 operations at 4.0 amps, 30VDC Resistive	Wire Leads	Standard	EF-103	5-17 oz.	4 oz.	.050 in.	.004 in.	.003 in.			
Series EF													
	2 CKT (1 PDT) Mom.	125/250VAC, 30 amps Resistive 125/250VAC, 20 amps Inductive 125/250VAC, 10 amps Motor 28VDC, 40 amps Resistive 28VDC, 30 amps Inductive 28VDC, 15 amps Motor 25,000 Operations Min.	Solder	MS25357-1	G3-44	50.75 oz	6 oz.	0.093 in.	.055 +/- .010 in.	.015 in.			
Series G													
	6 CKT 3 N.O. 3 N.C.	15 amps, 125/250VAC, 60/400 Hz, 15 Amp Ind., 30VDC Resistive 10 amps, 30VDC Inductive 50,000 operations	Side Solder	Standard U.L. Listed - 30A, 250VAC MS25356-1 MS25353-1, Reset Type	K3-4 K3-12 K3-44 K3-344	56 oz.	4 oz.	.060 in.	.028 +/- .007 in.	.015 in.			
Series K													
	2 CKT Dbl. Brk.	750,000 operations at 10 amps, 125VAC 10,000 operations at 1 amp, 125VAC pilot duty 200,000 operations at 10 amps, 30VDC res & ind	End Solder End Screw Side Solder	Standard	S1-4 S2-4 S3-4	12+/-3 oz.	4 oz.	.060 in.	.020 +/- .005in	.015in			
	2 CKT Dbl. Brk.	50,000 minimum operation 125VAC, 10 amps Resistive & Inductive 30VDC, 10 amps Resistive & Inductive 125VAC, 6 amps motor 28VDC, 6 amps motor	End Solder End Screw	MS25342-1, .027 max move. diff. MS25344-1, .027 max move. diff.	S1-44 S2-44	1.25 lbs 12 +/-3 oz	4 oz.	.060 in.	0.027	.015 in.			
Series S													
	1 PNC Dbl brk. 1 PNO Dbl brk.	750,000 operations at 10 amps, 125VAC 10,000,000 oper. at 1 amp, 125VAC pilot duty 200,000 operations at 10 amps, 30VDC Inductive Military rated for 10 amps 125/250VAC, 30VDC	Side Solder End Screw Side Solder Side Solder	MS25343-1, .020+/- .005 move diff Standard .020 +/- .005 move. diff. Standard .010 +/- .004-.003 mv df U.L. Listed	S3-44 S2-25 S3-5 S3-6	19 oz. 15 oz. 15 oz. 15 oz.							+/- .020in

BASIC SWITCHES

Precision Snap Action Switches

APPROXIMATE DIMENSIONS

Terminal Styles (Other terminations available)

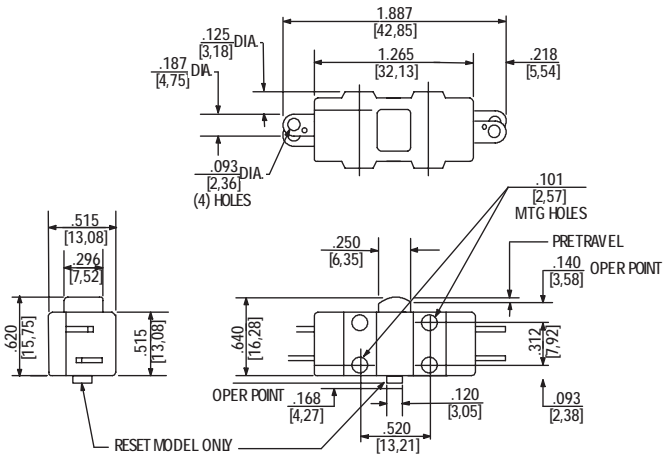
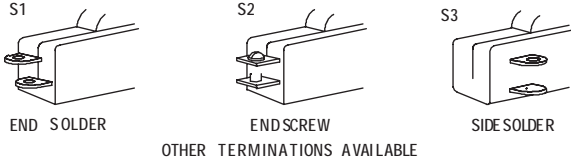

Series S

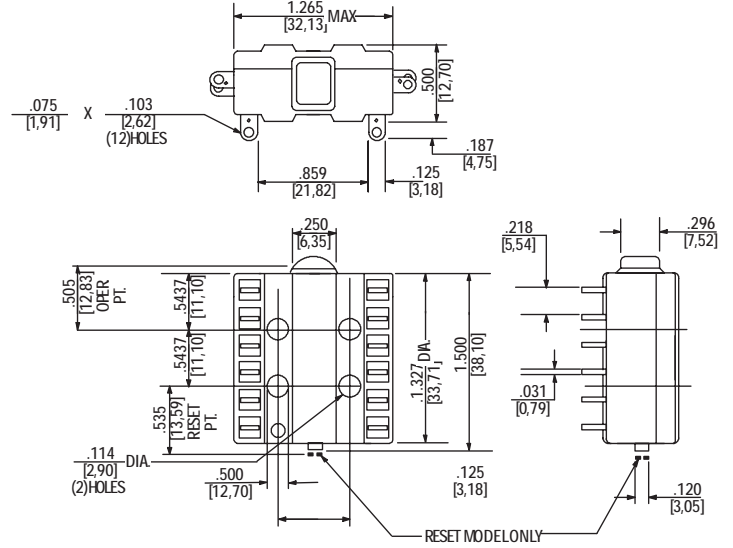

Series K

STANDARD

0.00 = inches

[0,0] = mm

Dimensions for reference only.

**Precision Snap Action Switch
Roller and Leaf Actuator**

FEATURES

- All parts treated for corrosion resistance
- Actuator metal parts are stainless passivated
- Operating characteristics depend on switch selected
- Catalog numbers which appear with a slash between actuator and basic switch part number are screw type assemblies and can be supplied as separate components

WHEN ORDERING SPECIFY . . .

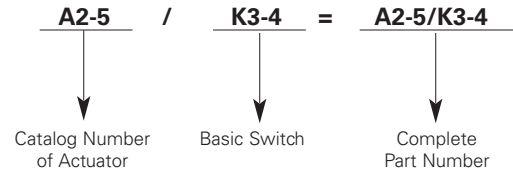

- Catalog number of actuator plus part number of basic switch.

Order Example:



SELECTION AND SPECIFICATIONS TABLE

TYPE

	Circuit	Electrical Rating Life	Catalog Number	Characteristics				
				Operating Force (Max.)	Release Force (Min.)	Pretravel (Max.)	Diff. Travel	Over Travel
 <p>Roller Lever Type A2-5</p> <p>Actuator A2-5 Shown with Basic Switch K3-4</p>	3 PDT 6 CKT Momentary	Can be used with "D" or "K" series basic switch shown on pg D2.	A2-5/K3-4	14 oz.	1 oz.	.240 in.	112 +/- .028 in.	.060 in.
 <p>Extended Leaf Type A5-18</p> <p>Actuator A5-18 Shown with Basic Switch D8-4</p>	2 PDT 4 CKT Momentary	Can be used with "D" or "K" series basic switch shown on pg D2.	A5-18/D8-4	16 +/- 4 oz.		.375 in +/- .066 in.	.156 in.	.156 in.

APPROXIMATE DIMENSIONS

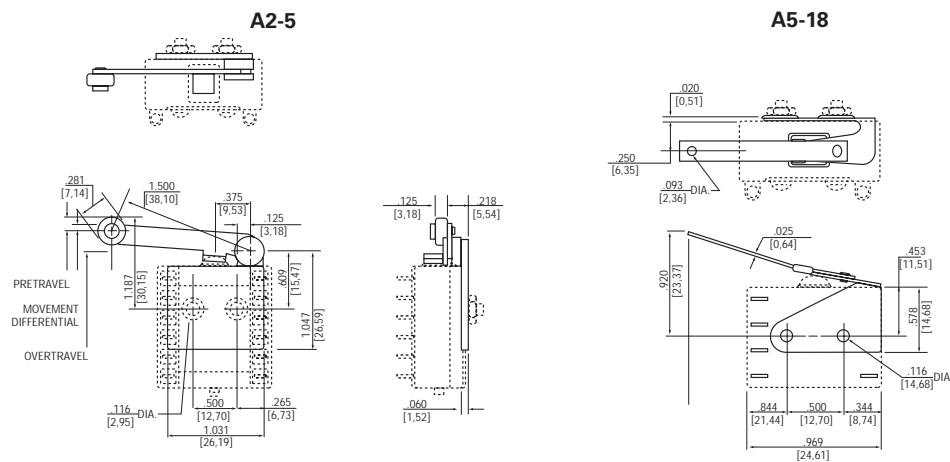

Sealed Limit Switches Index

Index

E1

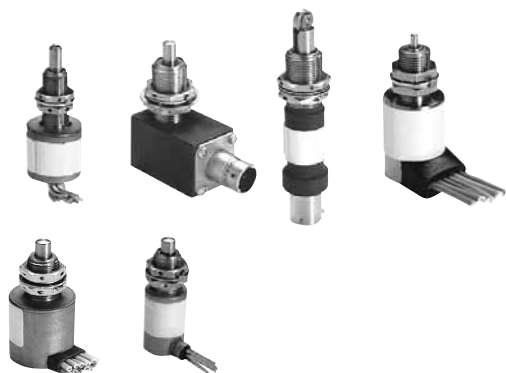
**H11 Series**

E2 - E3

- Ratings up to 7 amperes
- Two and four pole configurations
- Wire leads (6 foot length)
- One hole mounting
- MIL-S-8805 approved
- Available with pushbutton or roller actuator
- Available with glass-to-metal seal or phenolic disc header
- Custom designs available

**Hermetic Switches**

E4

- Ratings up to 7 amperes
- MIL-S-8805 Enclosure Design 5 (Hermetic)
- Stainless steel construction
- Inert gas filled
- Plunger or roller actuator
- Two and four pole configurations
- Custom designs available

**Most items listed in this catalog are standard products and are normally in Distributor Inventory; however, the current inventory status should be checked by contacting your Eaton Customer Service Representative at 800-955-7354 or your authorized Distributor before placing orders.*

LIMIT SWITCHES

Series - H11

Environmentally Sealed Switches

FEATURES

- Current ratings up to 7 amperes
- Two and four pole configurations
- Wire leads with strain relief
- Connector option available
- Single hole mounting
- Ice scraping capability
- Simultaneous contact circuitry
- Reliable lifetime operation
- Durable construction for harsh environment applications
- Wiring schematic located on switch body
- Customized to fit your exact application

SPECIFICATIONS

- MILS-8805 approved
- Enclosure per MILS-8805 Design 4 (Resilient)
- Wire leads per MIL-W-22759/7
- Operating temperature range: -65°F to +185°F (-55°C to + 85°C)
- Electrical life: 25,000 cycles at rated load
- Mechanical life: 25,000 cycles
- All metal parts treated for corrosion resistance

CURRENT RATINGS

Amperes - 28VDC

Altitude	Inrush	Resistive	Motor	Inductive
Sea Level	24	7	4	4
50,000 Feet	24	7	4	2.5
100,000 Feet	24	7	4	1.5



Cat. No. H11-375



Cat. No. H11-330



Cat. No. H11-395



Cat. No. H11-390



Cat. No. H11-335



Cat. No. H11-331

SELECTION TABLE - All switches shown have 6-foot length lead wire per MIL-W-22759/7 marked per MIL-W-5088.

Poles and Throw	Characteristics						MS Part Number	Catalog Number	Weight (oz.)	Bushing Thread Size	Housing Dimensions Inches Standard Base	
	Actuator	Op. Force	Return Force	Pre-Travel	Over-Travel	Diff. Travel					Height "A" Dim.	Diameter "B" Dim.
STANDARD SWITCH SERIES												
2 PDT	Plunger	6-12 lbs.	4 lbs. min.	.040 in. max.	.250 in. min.	.020 in. max.	MS21321-1 (8805/39)	H11-335	7.2	.625-24	.980	.720
4 PDT	Plunger	6-12 lbs.	4 lbs. min.	.040 in. max.	.250 in. min.	.020 in. max.	MS21321-2 (8805/39)	H11-395	12.5	.625-24	1.20	1.03
2 PDT	Plunger	6-12 lbs.	4 lbs. min.	.070 in. min.	.250 in. max.	.020 in. max.	MS24331-1 (8805/40)	H11-375	7.3	.625-24	.980	1.015
2 PDT	Plunger	6-12 lbs.	4 lbs. min.	.040 in. max.	.125 in. min.	.020 in. max.	MS27240-1 (8805/43)	H11-330	8	.469-32	1.0	.720
4 PDT	Plunger	6-12 lbs.	4 lbs. min.	.040 in. max.	.125 in. min.	.020 in. max.	MS27240-2 (8805/43)	H11-390	13.6	.469-32	1.20	1.03
2 PDT	Roller Plunger	6-12 lbs.	4 lbs. min.	.040 in. min.	.125 in. min.	.020 in. max.	MS27240-3 (8805/43)	H11-331	8	.32	1.0	.720
4 PDT	Roller Plunger	6-12 lbs.	4 lbs. min.	.040 in. max.	.125 in. min.	.020 in. max.	MS27240-4 (8805/43)	H11-391	13.6	.469-32	1.20	1.03

STANDARD ACTUATOR

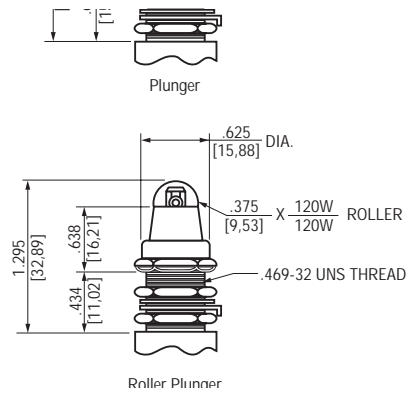
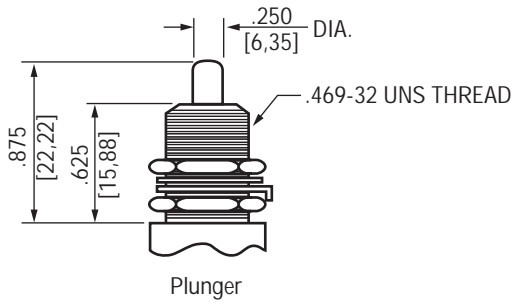

Plunger Operated - As with all push-on units, this actuator has an ice scraper for clearing the plunger of ice and debris with each operation.

Roller Plunger - For cam and slide actuation. Roller adjusts radially in 45° increments. Cam differential should not exceed 0.125 in., and cam slope should not exceed 30°.

SCHEMATIC

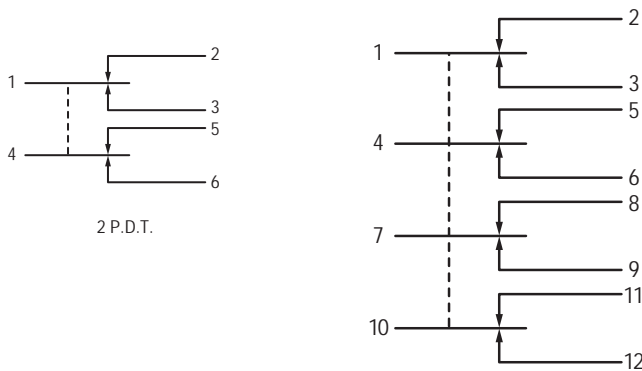

BASIC CONSTRUCTION

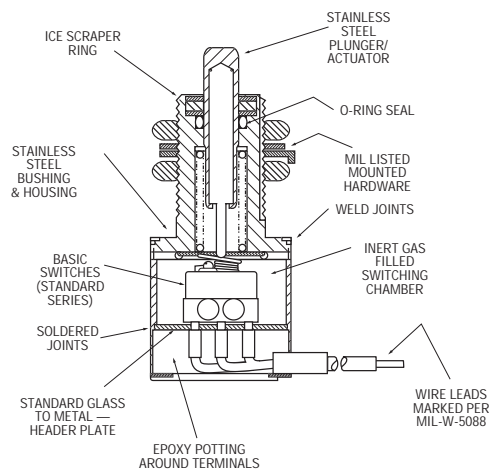

STANDARD
 0.00 = inches
 [0,0] = mm

Dimensions for reference only.

LIMIT SWITCHES

Series - HH

Hermetically Sealed Switches

FEATURES & SPECIFICATIONS

OPTIONS

CURRENT RATINGS

- Meets MILS-8805 Enclosure Design 5 (Hermetic)
- Mechanical life: 25,000 cycles
- Electrical life: 25,000 cycles
- Operating temperature: -65°F to +185°F (-55°C to +85°C)
- Leak rate less than 1×10^{-8}
- Rugged stainless steel construction
- Inert gas filled

- Low level circuitry capability
- Rear or side exit connector
- RFI/EMI shielded cable
- High temperature operation
- Ball bearing plunger
- Custom bushing and plunger sizes
- Roller plunger available in 45° increments
- Special purpose designs

	Amperes - 28VDC		
	Resistive	Inductive	Motor
Sea Level	7.0	4.0	4.0
50,000 feet	7.0	2.5	4.0
Low Level Rating	0.1	0.1	—

HERMETICALLY SEALED LIMIT SWITCHES



TWO POLE MINIATURE

P/N	DESCRIPTION
HH-630A	Plunger Side Exit
HH-630B	Plunger Rear Exit
HH-631A	Roller Side Exit
HH-631B	Roller Rear Exit

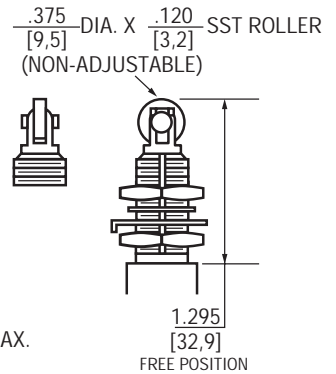
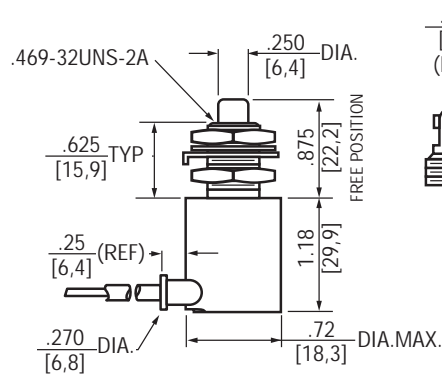
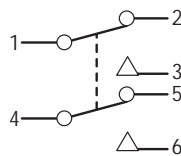

FOUR POLE SERIES

P/N	DESCRIPTION
HH-695A	Plunger Side Exit
HH-695B	Plunger Rear Exit
HH-696A	Roller Side Exit
HH-696B	Roller Rear Exit

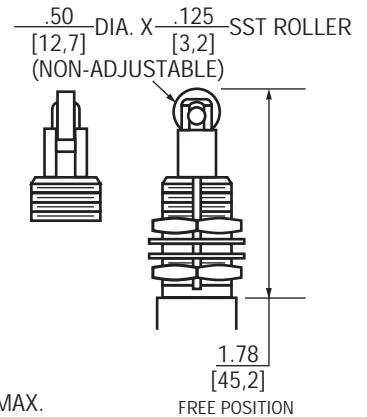
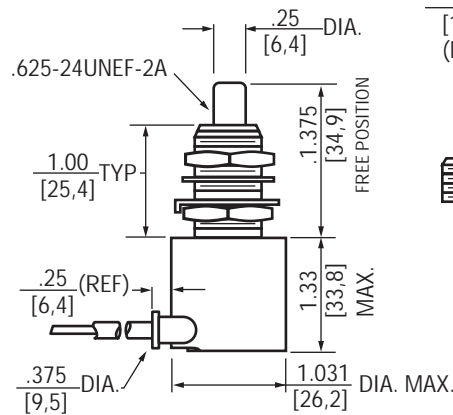
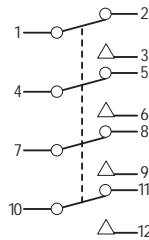

TYPICAL CONSTRUCTION - REAR EXIT DESIGN

HARDWARE SUPPLIED
UNASSEMBLED

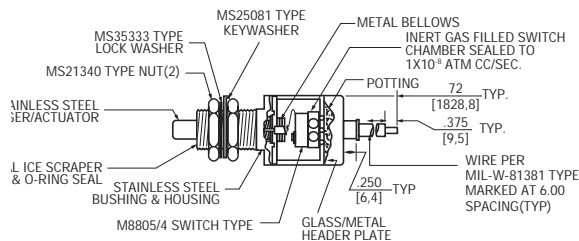

STANDARD

0.00 = inches

[0,0] = mm

Dimensions for reference only.

Switch Guards & Shields

Index

F1

Switch Guards

F2 - F6



- Prevent accidental operation of switches
- Switch operation limited to selected functions
- Adaptable to one, two and four pole configurations
- One hole or flush mounted variations

Pushbutton Shields

F7



- Guard pushbuttons against accidental operation
- Fit most pushbutton switches
- Three different styles
- Three different colors

**Most items listed in this catalog are standard products and are normally in Distributor Inventory; however, the current inventory status should be checked by contacting your Eaton Customer Service Representative at 800-955-7354 or your authorized Distributor before placing orders.*

SWITCH GUARDS & SHIELDS

Switch Guards MIL-G-7703 and Industrial Grade

FEATURES

- For use with 2 or 3 position switches
- Lever covers molded in various colors
- Cover closure transfers toggle lever. See code number for details.
- Metal and molded covers
- Flush and One Hole Mounted (OHM) mounting styles
- MS approved and QPL'd per MIL-G-7703
- Covers are molded out of Thermoset molding materials
- Guard covers are spring loaded to either close or lock in open position
- One hole mounting and three hole mounting available
- Keyway orientation variations offered on some guards



Code 1



Code 2, 3, 16, 17



Code 7, 8, 10-14



Code 9



Code 6



Code 4, 5



Code 18-25



Code 26-29



Code 15

SELECTION TABLE

Switch Guard Code Number	Switch Mounting	Switch Positions	Lever Material	Color ^④	Marking ^②		Location of Keyway Tab	Military Part Number	Catalog Number
					Hinged End	Other End			
1	Flush	3	Phenolic	Red	—	—	—	MS25223-1	8496K1 ^①
2	Flush	2	Phenolic	Red	—	—	—	MS25224-2	8497K2
3	Flush	3	Phenolic	Red	—	—	—	MS25225-2	8499K2
4	Flush	2	Metal	Green	—	—	—	MS25452-1	8498K2
5	Flush	2	Metal	Green	EMERGENCY	—	—	NAF47851-1	K2
6	Flush/OHM	2 or 3	Metal ^③	Black	—	—	—	MS25221-1	8495K1
7	OHM	3	Phenolic	Red	—	—	Opp. Hinged End	MS25214-2	8494K2
8	OHM	3	Phenolic	Red	—	—	Hinged End	MS25214-3	K3
9	OHM	3	Phenolic	Red	—	—	Opp. Hinged End	MS25223-2	8496K2
10	OHM	2	Phenolic	Red	—	—	Opp. Hinged End	MS25224-1	8497K1
11	OHM	2	Phenolic	Red	—	—	Hinged End	MS25224-3	8497K3
12		2	Phenolic	Red	ON	OFF	Opp. Hinged End	—	K7
13		3	Phenolic	Red	—	—	Opp. Hinged End	MS25225-1	8498K1
14		3	Phenolic	Red	—	—	Hinged End	MS25225-3	K3
15		2 or 3	Metal ^③	Black	—	—	Opp. Pin Hole	MS24417-1	8492K1
16	2 or 3	Phenolic	Red	—	—	Opp. Hinged End	MS27752-1	8498K6	
17	Flush	3	Phenolic	Red	—	—	—	MS25214-1	8494K1
18	OHM	3	Metal	Red	—	—	Hinged End	MS25214-1	8493K4
19		3		Red	—	—	Opp. Hinged End		K5
20		2		Red	—	—	Hinged End		K6
21		2		Red	—	—	Opp. Hinged End		K7
22		3		Black	—	—	Hinged End		K8
23		3		Black	—	—	Opp. Hinged End		8493K9
24	OHM	2	Metal	Black	—	—	Hinged End	K10	
25		2		Black	—	—	Opp. Hinged End	K11	
26		3		Red	—	—	Right Side	K12	
27		3		Red	—	—	Left Side	K13	
28		3		Black	—	—	Right Side	K14	
29	3	Black	—	—	Left Side	K15			

^① Will not return lever when mounting plate is over .0625 [1,58] thick.

^② Custom lettering or symbols available.

^③ Guard has no moving lever.

^④ Optional colors: black phenolic available for 8497. Where other colors are required, they are sprayed over standard color.

SPECIFICATIONS

Code 1 and 9

- For three-position switches
- Returns lever to center position from either extreme
- Guard housing is spring loaded to retain closed position

Code 2, 10, 11 and 12

- For full throw single throw switches
- Returns lever to OFF position

Code 3, 13 and 14

- For three-position switches
- Returns lever from up position to center position
- Will not change toggle position when it is in down position

Code 4 and 5

- For two-position full throw switches
- Permits locking toggle in extreme up position

Code 6 and 15

- Insertion of pin through guard prevents accidental operation
- Prevents transfer of single throw switches
- Permits operation from first position to center on three-position switches

Code 17

- For three-position flush mount switches
- Guard lever remains fixed in open or closed position
- Return lever to center position from either extreme

Code 7 and 8

- For three-position switches
- Returns lever to center position from either extreme
- Guard housing remains fixed in open and closed position

Code 16

- For two- or three-position switches
- Closing guard does not affect toggle position

Code 18, 19, 22 and 23

- For three-position switches
- Returns lever from up position to center position
- Will not change toggle position when it is in down position

Code 20, 21, 24 and 25

- For two-position full throw switches
- Returns lever from up position to down position

Code 26-29

- For three-position switches
- With both guards in closed position, switch toggle lever is locked in center position. With one guard each in open and closed position, switch can be toggled between center and open guard position; with both guards in open position, switch can be toggled between left, center, and right position.

SWITCH GUARDS & SHIELDS

Switch Guard Application Table

Switch Catalog Number ^①	Switch Guard Code Number	Switch Catalog Number ^①	Switch Guard Code Number
8200K7 8201K6, K14 8209K6 8210K7 8211K7	1, 3, 6, 17 2, 4, 5, 6 3, 6 6 2, 6	8837K4 & K94 K5 & K95 K6 & K96 K7 & K97 K8 & K98	10, 11, 15, 16, 20, 21, 24, 25 10, 11, 15, 16, 21, 25 13, 15, 16, 19, 23, 26-29 7, 9, 13, 15, 16 11, 15, 16
8212K6 8500K1 K2 K3 K4	3, 6 7, 9, 13, 14, 15, 16, 18, 19, 22, 23, 26-29 13, 14, 15, 16, 18, 19, 22, 26-29 13, 14, 15, 16, 18, 19, 22, 26-29 10, 11, 15, 16, 20, 21, 24, 25	8837K9 & K99 K10 & K910 K11 & K911 8838K1 & K91 K2 & K92	10, 12, 15, 16, 21, 25 10, 11, 15, 16, 21, 25 10, 11, 15, 16, 21, 25 7, 9, 13, 14, 15, 16, 18, 19, 22, 23, 26-29 13, 14, 15, 16, 18, 19, 22, 26-29
8500K5 K6 K7 K8 K9	10, 11, 15, 16, 21, 25 13, 15, 16, 19, 23, 26-29 7, 9, 13, 15, 16 11, 15, 16 10, 12, 15, 16, 21, 25	8838K3 & K93 K4 & K94 K5 & K95 K6 & K96 K7 & K97	13, 14, 15, 16, 18, 19, 22, 26-29 10, 11, 15, 16, 20, 21, 24, 25 10, 11, 15, 16, 21, 25 13, 15, 16, 19, 23, 26-29 7, 9, 13, 15, 16
8500K10 K11 K12 K13 8501K1	10, 11, 15, 16, 21, 25 10, 11, 15, 16, 21, 25 15, 16 13, 15, 16, 19, 23 7, 9, 13, 14, 15, 16, 18, 19, 22, 23, 26-29	8838K8 & K98 K9 & K99 K10 & K910 K11 & K911 8868K1, K51, K61	11, 15, 16 10, 12, 15, 16, 21, 25 10, 11, 15, 16, 21, 25 10, 11, 15, 16, 21, 25 7, 9, 13, 14, 15, 16, 18, 19, 22, 23, 26-29
8501K2 K3 K4 K5 K6	13, 14, 15, 16, 18, 19, 22, 26-29 13, 14, 15, 16, 18, 19, 22, 26-29 10, 11, 15, 16, 20, 21, 24, 25 10, 11, 15, 16, 21, 25 13, 15, 16, 19, 23, 26-29	8868K2, K52, K62 K3, K53, K63 K4, K54, K64 K5, K55, K65 K6, K56, K66	13, 14, 15, 16, 18, 19, 22, 26-29 13, 14, 15, 16, 18, 19, 22, 26-29 10, 11, 15, 16, 20, 21, 24, 25 10, 11, 15, 16, 21, 25 9, 13, 15, 16
8501K7 K8 K9 K10 K11	7, 9, 13, 15, 16 11, 15, 16 10, 12, 15, 16, 21, 25 10, 11, 15, 16, 21, 25 10, 11, 15, 16, 21, 25	8868K7, K57, K67 K8, K58, K68 8869K1, K1X, K51, K51X, K61, K61X K2, K2X, K52, K52X, K62, K62X K3, K3X, K53, K53X, K63, K63X	10, 12, 15, 16, 21, 25 10, 12, 15, 16, 21, 25 7, 9, 13, 14, 15, 16, 18, 19, 22, 23, 26-29 13, 14, 15, 16, 18, 19, 22, 26-29 13, 14, 15, 16, 18, 19, 22, 26-29
8501K12 K13 K14 thru K19 8502K1 K2	15, 16 13, 15, 16, 19, 23 7, 9, 13, 15, 16, 18, 19, 22, 23, 26-29 7, 9, 13, 14, 15, 16, 18, 19, 22, 23, 26-29 13, 14, 15, 16, 18, 19, 22, 26-29	8869K4, K4X, K54, K54X, K64, K64X K5, K5X, K55, K55X, K65, K65X K6, K6X, K56, K56X, K66, K66X K7, K7X, K57, K57X, K67, K67X 8867K8, K8X, K58, K58X, K68, K68X	10, 11, 15, 16, 20, 21, 24, 25 10, 11, 15, 16, 21, 25 7, 9, 13, 15, 16 10, 12, 15, 16, 21, 25 10, 12, 15, 16, 21, 25
8502K3 K4 K5 K6 K7	13, 14, 15, 16, 18, 19, 22, 23, 26-29 10, 11, 15, 16, 20, 21, 24, 25 10, 11, 15, 16, 21, 25 13, 15, 16, 19, 23, 26-29 7, 9, 13, 15, 16	8869K9, K9X, K59, K59X, K69, K69X K10, K10X, K510, K510X, K610, K610X K11, K11X, K511, K511X, K611, K611X 8854K1 8854K2	7, 9, 13, 14, 15, 16, 18, 19, 22, 23, 26-29 13, 14, 15, 16, 18, 19, 22, 26-29 13, 14, 15, 16, 18, 19, 22, 26-29 7, 9, 13, 14, 15, 16, 18, 19, 22, 23, 26-29 13, 14, 15, 16, 18, 19, 22, 26-29
8502K8 K9 K10 K11 K12	11, 15, 16 10, 12, 15, 16, 21, 25 10, 11, 15, 16, 21, 25 10, 11, 15, 16, 21, 25 15, 16	8854K3 K4 K5 K6 K7	13, 14, 15, 16, 18, 19, 22, 26-29 10, 11, 15, 16, 20, 21, 24, 25 10, 11, 15, 16, 21, 25 7, 9, 13, 15, 16 10, 12, 15, 16, 21, 25
8502K13 K15 thru K17 8700K15 8701K14 8709K15	13, 15, 16, 19, 23 7, 9, 13, 15, 16, 18, 19, 22, 23, 26-29 1, 3, 6, 17 4, 5, 6 3, 6	8854K8 K9 K10 K11	10, 12, 15, 16, 21, 25 7, 9, 13, 14, 15, 16, 18, 19, 22, 23, 26-29 13, 14, 15, 16, 18, 19, 22, 26-29 13, 14, 15, 16, 18, 19, 22, 26-29
8718K5 8740K12 8742K10 8744K10 8790K4	3, 6 2, 6 3, 6, 17 2, 6 6	8570K1-16, -20 K2-16, -20 K3-16, -20 K4-16, -20 K5-16, -20	7, 9, 13, 14, 16, 18, 19, 22, 23, 26-29 13, 14, 16, 18, 19, 22, 26-29 13, 14, 16, 18, 19, 22, 26-29 10, 11, 16, 20, 21, 24, 25 10, 11, 16, 21, 25
8792K3 8836K1 & K91 K2 & K92 K3 & K93 K4 & K94	6 7, 9, 13, 14, 15, 16, 18, 19, 22, 23, 26-29 13, 14, 15, 16, 18, 19, 22, 26-29 13, 14, 15, 16, 18, 19, 22, 26-29 10, 11, 15, 16, 20, 21, 24, 25	8570K6-16, -20 K7-16, -20 K8-16, -20 K9-16, -20 K10-16, -20	13, 16, 19, 23, 26-29 7, 9, 13, 16 11, 16 10, 12, 16, 21, 25 10, 11, 16, 21, 25
8836K5 & K95 K6 & K96 K7 & K97 K8 & K98 K9 & K99	10, 11, 15, 16, 21, 25 13, 15, 16, 19, 23, 26-29 7, 9, 13, 15, 16 11, 15, 16 10, 12, 15, 16, 21, 25	8570K11-16, -20 K12-16, -20 K13-16, -20 8571K1-16, -20 K2-16, -20	10, 11, 16, 21, 25 16 13, 16, 19, 23 7, 9, 13, 14, 16, 18, 19, 22, 23, 26-29 13, 14, 16, 18, 19, 20, 26-29
8836K10 & K910 K11 & K911 8837K1 & K91 K2 & K92 K3 & K93	10, 11, 15, 16, 21, 25 10, 11, 15, 16, 21, 25 7, 9, 13, 14, 15, 16, 18, 19, 22, 23, 26-29 13, 14, 15, 16, 18, 19, 22, 26-29 13, 14, 15, 16, 18, 19, 22, 26-29	8571K3-16, -20 K4-16, -20 K5-16, -20 K6-16, -20 K7-16, -20	13, 14, 16, 18, 19, 22, 26-29 10, 11, 16, 20, 21, 24, 25 10, 11, 16, 21, 25 13, 16, 19, 23, 26-29 7, 9, 13, 16

① Listing covers only those switches that can be used with a switch guard.

SWITCH GUARDS & SHIELDS

Switch Guard Application Table

Switch Catalog Number ^①	Switch Guard Code Number	Switch Catalog Number ^①	Switch Guard Code Number
8571K8-16, -20 K9-16, -20 K10-16, -20 K11-16, -20 K12-16, -20	11, 16 10, 12, 16, 21, 25 10, 11, 16, 21, 25 10, 11, 16, 21, 25 16	8520K1 K4 K9 8521K1 K4	7, 9, 13, 14, 15, 16, 18, 19, 22, 23, 26-29 10, 11, 15, 16, 20, 21, 24, 25 10, 12, 15, 16, 21, 25 7, 9, 13, 14, 15, 16, 18, 19, 22, 23 10, 11, 15, 16, 20, 21, 24, 25
8571K13-16, -20 K17-16, -20 K18-16, -20 K19-16, -20 8572K1-16, -20	13, 16, 19, 23 7, 9, 13, 16, 18, 19, 22, 23, 26-29 13, 14, 16, 18, 19, 22, 26-29 13, 14, 16, 18, 19, 22, 26-29 7, 9, 13, 14, 16, 18, 19, 22, 23, 26-29	8521K9 8522K1 K4 K9 8526K2	10, 12, 15, 16, 20, 21, 24, 25 7, 9, 13, 14, 15, 16, 18, 19, 22, 23, 26-29 10, 11, 15, 16, 20, 21, 24, 25 10, 12, 15, 16, 21, 25 13, 14, 15, 16, 18, 19, 22, 26-29
8572K2-16, -20 K3-16, -20 K4-16, -20 K5-16, -20 K6-16, -20	13, 14, 16, 18, 19, 22, 26-29 13, 14, 16, 20, 21, 24, 25 10, 11, 16, 20, 21, 24, 25 10, 11, 16, 21, 25 13, 16, 19, 23, 26-29	8526K3 K5 8527K2 K3 K5	13, 14, 15, 16, 18, 19, 22, 26-29 10, 11, 15, 16, 21, 25 13, 14, 15, 16, 18, 19, 22, 26-29 13, 14, 15, 16, 18, 19, 22, 26-29 10, 11, 15, 16, 21, 25
8572K7-16, -20 K8-16, -20 K9-16, -20 K10-16, -20 K11-16, -20	7, 9, 13, 16 11, 16 10, 12, 16, 21, 25 10, 11, 16, 21, 25 10, 11, 16, 21, 25	8528K2 K3 K5 8530K1, K31, K91 K2, K32, K92	13, 14, 15, 16, 18, 19, 22, 26-29 13, 14, 15, 16, 18, 19, 22, 26-29 10, 11, 15, 16, 21, 25 7, 9, 13, 14, 15, 16, 18, 19, 22, 23, 26-29 13, 14, 15, 16, 18, 19, 22, 26-29
8572K12-16, -20 K13-16, -20 K15-16, -20 K16-16, -20 K17-16, -20	16 13, 16, 19, 23 7, 9, 13, 16, 18, 19, 22, 23, 26-29 13, 14, 16, 18, 19, 22, 26-29 13, 14, 16, 18, 19, 22, 26-29	8530K3, K33, K93 K4, K34, K94 K5, K35, K95 K6, K36, K96 K7, K37, K97	13, 14, 15, 16, 18, 19, 22, 26-29 10, 11, 15, 16, 20, 21, 24, 25 10, 11, 15, 16, 21, 25 13, 15, 16, 19, 23, 26-29 7, 9, 13, 15, 16
8510K1 K2 K3 K4 K5	7, 9, 13, 14, 15, 16, 18, 19, 22, 23, 26-29 13, 14, 15, 16, 18, 19, 22, 26-29 13, 14, 15, 16, 18, 19, 22, 26-29 10, 11, 15, 16, 20, 21, 24, 25 10, 11, 16, 21, 25	8530K8, K38, K98 K9, K39, K99 K10, K310, K910 K11, K311, K911 K12, K312, K912	11, 15, 16 10, 12, 15, 16, 21, 25 10, 11, 15, 16, 21, 25 10, 11, 15, 16, 21, 25 15, 16
8510K6 K7 K8 K9 K10	13, 15, 16, 18, 23, 26-29 7, 9, 13, 15, 16 11, 15, 16 10, 12, 15, 16, 21, 25 10, 11, 15, 16, 21, 25	8530K13, K313, K913 8531K1, K31, K91 K2, K32, K92 K3, K33, K93 K4, K34, K94	13, 15, 16, 19, 23 7, 9, 13, 14, 15, 18, 19, 22, 23, 26-29 13, 14, 15, 16, 18, 19, 22, 26-29 13, 14, 15, 16, 18, 19, 22, 26-29 10, 11, 15, 16, 20, 21, 24, 25
8510K11 K12 K13 8511K1 K2	10, 11, 15, 16, 21, 25 15, 16 13, 15, 16, 19, 23 7, 9, 13, 14, 15, 16, 18, 19, 22, 23, 26-29 13, 14, 15, 16, 18, 19, 22, 26-29	8531K5, K35, K95 K6, K36, K96 K7, K37, K97 K8, K38, K98 K9, K39, K99	10, 11, 15, 16, 21, 25 13, 15, 16, 19, 23, 26-29 7, 9, 13, 15, 16 11, 15, 16 10, 12, 15, 16, 21, 25
8511K3 K4 K5 K6 K7	13, 14, 15, 16, 18, 19, 22, 26-29 10, 11, 15, 16, 20, 21, 24, 25 10, 11, 15, 16, 21, 25 13, 15, 16, 19, 23, 26-29 7, 9, 13, 15, 16	8531K10, K310, K910 K11, K311, K911 K12, K312, K912 K13, K313, K913 K14, K314, K914	10, 11, 15, 16, 21, 25 10, 11, 15, 16, 21, 25 15, 16 13, 15, 16, 19, 23 7, 9, 13, 15, 16, 18, 19, 22, 23, 26-29
8511K8 K9 K10 K11 K12	11, 15, 16 10, 12, 15, 16, 21, 25 10, 11, 15, 16, 21, 25 10, 11, 15, 16, 21, 25 15, 16	8531K15, K315, K915 K16, K316, K916 K17, K317, K917 K18, K318, K918 K19, K319, K919	13, 14, 15, 16, 18, 19, 22, 26-29 13, 14, 15, 16, 18, 19, 22, 26-29 7, 9, 13, 15, 16, 18, 19, 22, 23, 26-29 13, 14, 15, 16, 18, 19, 22, 26-29 13, 14, 15, 16, 18, 19, 22, 26-29
8511K13 K14 K15 K16 8512K1	13, 15, 16, 18, 23 7, 9, 13, 15, 16, 18, 19, 22, 23, 26-29 13, 14, 15, 16, 18, 19, 22, 26-29 13, 14, 15, 16, 18, 19, 22, 26-29 7, 9, 13, 14, 15, 16, 18, 19, 22, 23, 26-29	8532K1, K31, K91 K2, K32, K92 K3, K33, K93 K4, K34, K94 K5, K35, K95	7, 9, 13, 14, 15, 16, 18, 19, 22, 23, 26-29 13, 14, 15, 16, 18, 19, 22, 26-29 13, 14, 15, 16, 18, 19, 22, 26-29 10, 11, 15, 16, 20, 21, 24, 25 10, 11, 15, 16, 21, 25
8512K2 K3 K4 K5 K6	13, 14, 15, 16, 18, 19, 22, 26-29 13, 14, 15, 16, 18, 19, 22, 26-29 10, 11, 15, 16, 20, 21, 24, 25 10, 11, 15, 16, 21, 25 13, 15, 16, 19, 23, 26-29	8532K6, K36, K96 K7, K37, K97 K8, K38, K98 K9, K39, K99 K10, K310, K910	13, 15, 16, 19, 23, 26-29 7, 9, 13, 15, 16 11, 15, 16 10, 12, 15, 16, 21, 25 10, 11, 15, 16, 21, 25
8512K7 K8 K9 K10 K11 8512K12 K13 K15 K16 K17	7, 9, 13, 15, 16 11, 15, 16 10, 12, 15, 16, 21, 25 10, 11, 15, 16, 21, 25 10, 11, 15, 16, 21, 25 15, 16 13, 15, 16, 19, 23 7, 9, 13, 15, 16, 18, 19, 22, 23, 26-29 13, 14, 15, 16, 18, 19, 22, 26-29 13, 14, 15, 16, 18, 19, 22, 26-29	8532K11, K311, K911 K12, K312, K912 K13, K313, K913 K15, K315, K915 K16, K316, K916 8532K17, K317, K917	10, 11, 15, 16, 21, 25 15, 16 13, 15, 16, 19, 23 7, 9, 13, 15, 16, 18, 19, 22, 23, 26-29 13, 14, 15, 16, 18, 19, 22, 26-29 13, 14, 15, 16, 18, 19, 22, 26-29

① Listing covers only those switches that can be used with a switch guard.

SWITCH GUARDS & SHIELDS

Switch Guard Application Table

Switch Catalog Number ^①	Switch Guard Code Number	Switch Catalog Number ^①	Switch Guard Code Number
A3-10 SERIES A3-32 SERIES A3-33 SERIES A3-40 SERIES A3-200-01	10, 12, 15, 16, 21, 25 10, 11, 15, 16, 20, 21, 24, 25 10, 11, 15, 16, 20, 21, 24, 25 10, 11, 15, 16, 20, 21, 24, 25 7, 9, 13, 14, 15, 16, 18, 19, 22, 23	A3-206-06 -07 A3-208-01 -02 -03	10, 11, 15, 16, 21, 25 10, 11, 15, 16, 21, 25 7, 9, 13, 14, 15, 16, 18, 19, 22, 23 13, 14, 15, 16, 18, 19, 22, 26-29 13, 14, 15, 16, 18, 19, 22, 26-29
A3-200-02 -03 -04 -05	13, 14, 15, 16, 18, 19, 22, 26-29 13, 14, 15, 16, 18, 19, 22, 26-29 13, 14, 15, 16, 18, 19, 22, 26-29 10, 11, 15, 16, 20, 21, 24, 25	A3-208-04 -05 -06 -07	13, 14, 15, 16, 18, 19, 22, 26-29 10, 11, 15, 16, 20, 21, 24, 25 10, 11, 15, 16, 21, 25 10, 11, 15, 16, 21, 25
A3-200-07 A3-202-01 -02 -03 -04	10, 11, 15, 16, 21, 25 7, 9, 13, 14, 15, 16, 18, 19, 22, 23 13, 14, 15, 16, 18, 19, 22, 26-29 13, 14, 15, 16, 18, 19, 22, 26-29 13, 14, 15, 16, 18, 19, 22, 26-29	A3-210-02 -03 -04 -05 -06	13, 14, 15, 16, 18, 19, 22, 26-29 13, 14, 15, 18, 19, 22, 26-29 13, 14, 15, 16, 18, 19, 22, 26-29 10, 11, 15, 16, 20, 21, 24, 25 10, 11, 15, 16, 21, 25
A3-202-05 -06 -07 A3-204-01 -02	10, 11, 16, 20, 21, 24, 25 10, 11, 15, 16, 21, 25 10, 11, 15, 16, 21, 25 7, 9, 13, 14, 15, 16, 18, 19, 22, 23 13, 14, 15, 16, 18, 19, 22, 26-29	A3-210-07 A3-212-01 -02 -03 -04	10, 11, 15, 16, 21, 25 7, 9, 13, 14, 15, 16, 18, 19, 22, 23 13, 14, 15, 16, 18, 19, 22, 26-29 13, 14, 15, 16, 18, 19, 22, 26-29 13, 14, 15, 16, 18, 19, 22, 26-29
A3-204-03 -04 -05 -06 -07	13, 14, 15, 16, 18, 19, 22, 26-29 13, 14, 15, 16, 18, 19, 22, 26-29 10, 11, 15, 16, 20, 21, 24, 25 10, 11, 15, 16, 21, 25 10, 11, 15, 16, 21, 25	A3-212-05 -06 -07 A3-214-01 -02	10, 11, 15, 16, 20, 21, 24, 25 10, 11, 15, 16, 21, 25 10, 11, 15, 16, 21, 25 7, 9, 13, 14, 15, 16, 18, 19, 22, 23 12, 14, 15, 16, 18, 19, 22, 26-29
A3-206-01 -02 -03 -04 -05	7, 9, 13, 14, 15, 16, 18, 19, 22, 23 13, 14, 15, 16, 18, 19, 22, 26-29 13, 14, 15, 16, 18, 19, 22, 26-29 13, 14, 15, 16, 18, 19, 22, 26-29 10, 11, 15, 16, 20, 21, 24, 25	A3-214-03 -04 -05 -06 -07	13, 14, 15, 16, 18, 19, 22, 26-29 13, 14, 15, 16, 18, 19, 22, 26-29 10, 11, 15, 16, 20, 21, 24, 25 10, 11, 15, 16, 21, 25 10, 11, 15, 16, 21, 25

① Listing covers only those switches that can be used with a switch guard.

Pushbutton Shields for Series C100, D200W, H2200, J300, W100 and WC1500 Switches



FEATURES

- Protection against accidental actuation
- Rugged construction
- Anodized for corrosion protection
- Threaded or unthreaded
- Available in black, clear or red
- Various size ranges

DESCRIPTION

These anodized aluminum shields guard pushbuttons against accidental operation. Internally threaded and unthreaded, the shields are usually used on basic switches in place of mounting adapters, although Type W or other narrow adapters can be used with shields. Consult switch and adapter drawings for proper thread size when ordering shields. Order shields separately by part number.

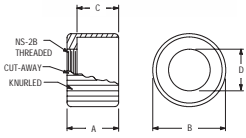
SELECTION TABLE

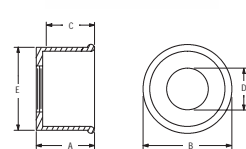
	Type	Active P/N	Obsolete P/N	Color	Dimension "A"	Dimension "B"	Dimension "C"	Dimension "D"	Dimension "E"	
 	Knurled Shields	73-2474	120011	Clear Anodized	.625"	.875"	.500"	1/2-32 NS-2B	—	
		73-2474-2	102012	Black Anodized	.625"	.875"	.500"	1/2-32 NS-2B	—	
		73-2474-3	102012	Red Anodized	.625"	.875"	.500"	1/2-32 NS-2B	—	
		73-2475	120016	Clear Anodized	.406"	.875"	.281"	1/2-32 NS-2B	—	
		73-2475-2	120017	Black Anodized	.406"	.875"	.281"	1/2-32 NS-2B	—	
		73-2475-3	120018	Red Anodized	.406"	.875"	.281"	1/2-32 NS-2B	—	
	Knurled Shields	73-2486	120081	Clear Anodized	.406"	.875"	.281"	5/8-24 NEF-2B	—	
		73-2486-2	120082	Black Anodized	.406"	.875"	.281"	5/8-24 NEF-2B	—	
		73-2486-3	120083	Red Anodized	.406"	.875"	.281"	5/8-24 NEF-2B	—	
		73-2487	120091	Clear Anodized	.406"	.875"	.281"	15/32-32 NS-2B	—	
		73-2487-2	120092	Black Anodized	.406"	.875"	.281"	15/32-32 NS-2B	—	
		73-2487-3	120093	Red Anodized	.406"	.875"	.281"	15/32-32 NS-2B	—	
		Smooth Shields	73-2478	120031	Clear Anodized	.688"	.957"	.641"	1/2" HOLE	—
			73-2478-2	120032	Black Anodized	.688"	.957"	.641"	1/2" HOLE	—
73-2478-3	120033		Red Anodized	.688"	.957"	.641"	1/2" HOLE	—		
Smooth Shields	73-2479	120036	Clear Anodized	.844"	.957"	.719"	5/8-24 NEF-28	—		
	73-2479-2	120037	Black Anodized	.844"	.957"	.719"	5/8-24 NEF-28	—		
	73-2479-3	120038	Red Anodized	.844"	.957"	.719"	5/8-24 NEF-28	—		
 	Rolled Edge Shields	73-2476	120021	Clear Anodized	.422"	1.063"	.375"	1/2" HOLE	61/64	
		73-2476-2	120022	Black Anodized	.422"	1.063"	.375"	1/2" HOLE	61/64	
		73-2476-3	120023	Red Anodized	.422"	1.063"	.375"	1/2" HOLE	61/64	
		73-2477	120026	Clear Anodized	.688"	1.063"	.641"	1/2" HOLE	61/64	
		73-2477-2	120027	Black Anodized	.688"	1.063"	.641"	1/2" HOLE	61/64	
		73-2477-3	120028	Red Anodized	.688"	1.063"	.641"	1/2" HOLE	61/64	
		73-2480	120041	Clear Anodized	.422"	1.063"	.375"	5/8" HOLE	61/64	
		73-2480-2	120042	Black Anodized	.422"	1.063"	.375"	5/8" HOLE	61/64	
		73-2480-3	120043	Red Anodized	.422"	1.063"	.375"	5/8" HOLE	61/64	
		73-2481	120046	Clear Anodized	.610"	1.188"	.563"	5/8" HOLE	1 3/32	
		73-2481-3	120048	Red Anodized	.610"	1.188"	.563"	5/8" HOLE	1 3/32	
		73-2485	120071	Clear Anodized	.688"	1.063"	.641"	5/8" HOLE	61/64	
		73-2485-2	120072	Black Anodized	.688"	1.063"	.641"	5/8" HOLE	61/64	
		73-2485-3	120073	Red Anodized	.688"	1.063"	.641"	5/8" HOLE	61/64	
	Rolled Edge Shields	73-2488	120106	Clear Anodized	.500"	1.063"	.375"	5/8-24 NEF-2B	61/64	
		73-2488-2	120107	Black Anodized	.500"	1.063"	.375"	5/8-24 NEF-2B	61/64	
		73-2488-3	120108	Red Anodized	.500"	1.063"	.375"	5/8-24 NEF-2B	61/64	
		73-2489-2⓪	120127	Clear Anodized	.719"	1.063"	.594"	5/8-24 NEF-2B	61/64	
		73-2489-3⓪	120128	Black Anodized	.719"	1.063"	.594"	5/8-24 NEF-2B	61/64	
		73-2489-4⓪	120129	Red Anodized	.719"	1.063"	.594"	5/8-24 NEF-2B	61/64	
		73-2490	120146	Clear Anodized	.547"	1.063"	.500"	5/8" HOLE	61/64	
73-2490-2	120147	Red Anodized	.547"	1.063"	.500"	5/8" HOLE	61/64			
73-2490-3	120148	Black Anodized	.547"	1.063"	.500"	5/8" HOLE	61/64			

⓪ May also be used with following mounting adapter types: A, B, D, DA, E, HA, P, PA, U, W.

Index

G1

**Protective Seals**

G2

- Panel seal for One Hole Mounting (OHM)
- O-Ring seals for panel mounting
- Switch boots

**Attachable Tips**

G3

- Vinyl slip-on types
- Fluorescent snap-on tips
- Thermoplastic shaped levers
- 3-Cateye lever assembly

**Mounting and Terminal Hardware**

G4 - G6

- Replacement hardware for military switches
- Optional hardware
- Mounting adapters for thick panel mounting
- Pushbutton mounting adapter

**Most items listed in this catalog are standard products and are normally in Distributor Inventory; however, the current inventory status should be checked by contacting your Eaton Customer Service Representative at 800-955-7354 or your authorized Distributor before placing orders.*

SECTION G - ACCESSORIES

Protective Seals

PANEL SEAL

PART NO. 32-341

- Prevents moisture and contaminants from entering panel enclosure
- Behind panel mounting
- Stainless steel cup washer assures proper seating of silicone rubber seal
- Seal withstands 20 psi water pressure
- MIL part number M5423/16-001 (Supercedes MIL part number MS25196-1)

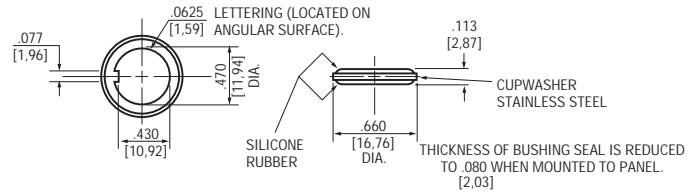

INSTRUCTIONS FOR ASSEMBLING BUSHING SEAL

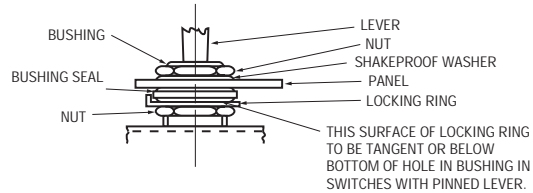

BUSHING SEAL TO BE ASSEMBLED SO THAT SURFACE, WITH MARKING "BOTTOM," IS DOWN. LOCKING RING CAN BE ASSEMBLED WITH EAR EITHER UP OR DOWN.

"O" RING SEAL

PART NO. 32-239-15

- Replacement panel seal for miniature positive action switches (8866 and 8867)
- Prevents entrance of contaminants into the panel enclosure
- Silicone rubber

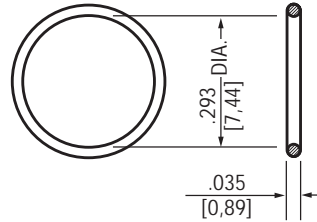

SWITCH BOOTS

Specifications

- Flexible silastic material prevents contaminants from entering switch
- 49-2030-2 designed for sealing Military high capacity switches (1-11/16" large lever)
- Popular 8864K2 consists of a boot 49-2033-2, nut 15-567, flexible washer 16-3084 and metal washer 16-1382



SELECTION TABLE

Application	Catalog or Part Number
Flush Mounted Switches	49-2030-2
One Hole Mounted Switches	8864K2

Adapter Nut and Attachable Tips

MOUNTING ADAPTER NUT FOR MINIATURE POSITIVE ACTION SWITCHES

- For 8866 and 8867 type miniature switches
- Facilitates thick panel mounting
- Three adapter sizes available

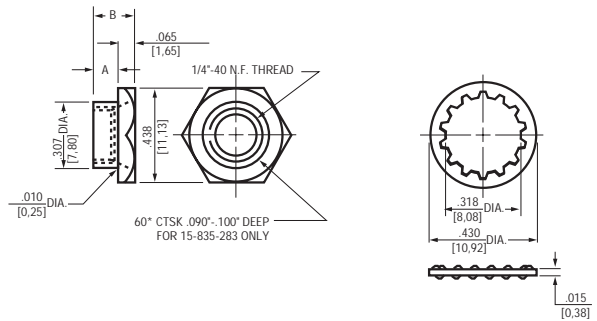

SELECTION TABLE



Dimension "A"	Dimension "B"	Panel Thickness (in.)		Part Number
		Standard Without Optional Lockwasher	With Optional Lockwasher Pt. No. 16-1880	
.067 [1,70] .077 [1,95]	.137 [3,47] Nominal	.107 [2,71] .157 [3,98]	.090 [2,28] .140 [3,55]	15-835
.129 [3,27] .139 [3,53]	.199 [5,05] Nominal	.169 [4,29] .219 [5,56]	.152 [3,86] .202 [5,13]	15-835-3
.192 [4,87] .202 [5,13]	.262 [6,65] Nominal	.232 [5,89] .282 [7,16]	.215 [5,46] .265 [6,73]	15-835-2

Mounting Adapter Nut

ATTACHABLE TIPS

- Facilitates identification of various switch functions
- 24-1939 tips nickel-plated for corrosion resistance
- 24-1939 tips snap on and are held by strong clip action at the base
- Vinyl slip-on lever caps available for both miniature and standard bat lever switches

SELECTION TABLE



Part Numbers
49-4307 and 49-4308



Part Numbers
49-4157 thru 49-4159

Application	Type of Tip	Government Part Number	Part Number
Attachable Tips			
Standard Bat Lever Switches	Fluorescent	AN3221-1	24-1939
Vinyl Slip-On Lever Caps			
Standard Bat Lever Switches	Black	-	49-4307
	Red	-	49-4308
Miniature Bat Lever Switches	Black	-	49-4157
	Red	-	49-4158
	White	-	49-4159



Part Number
24-1939

ACCESSORIES

Mounting and Terminal Hardware

Switch Catalog Number	Mounting Hardware ^①				Terminal Hardware ^①			
	Lock Nut	Face Nut	Lock Washer	Locking Ring	Terminal Screws	Terminal Lug or Nut	Lock Washer	Misc. Hardware
8500-8505 8510-8515 8520-8528 8530-8538 8540-8548	15-966-6 15-966-6 15-966-6 15-966-6 —	15-966-6 15-966-6 15-966-6 15-966-6 —	16-886 16-886 16-886 16-886 —	29-761 29-761 29-761 29-761 —	11-2379 11-2379 11-2379 11-2379 11-2379	— — — — —	— — — — —	— — — — —
8566-8568 8570-8575 8780-8782 8790-8792 8836-8838	15-966-6 15-966-6 — — 15-966-6	15-966-6 15-966-6 — — 15-966-6	16-886 16-886 — — 16-886	29-761 29-761 — — 29-761	11-2379 — — — 11-2379	— — 815-601-3 815-601-3 —	— — 16-365-2 16-3493 —	— — 16-421-5 821-1114-6 —
8843-8845 8855-8856 8866-8867 8868-8869 A11200	15-966-6 15-966-6 — 15-966-6 15-1577	15-966-6 15-966-6 15-454-13 15-966-6 Adapter	16-886 16-886 16-1751 16-886 16-3207	29-761 29-761 — 29-761 —	11-2379 — — — 11-4177	— — — — 80-4961	— — — — 16-3257-22	— — 32-239-15 — —
A1224BT A1285BT A20267 A20271 A20272	— — — — —	15-1574 15-1574 15-1594 15-1594 15-1594	16-3209 16-3209 15-3215-3 16-3215-3 16-3215-3	— — 52-2075 52-2075 52-2075	11-4074 11-4074 — — —	— — — — —	16-3257-12 16-3257-12 — — —	— — — — —
A20273 A3-200 thru A3-215 A3-32-270 A3-41-270 thru A3-48-270	— 15-1594 — — 15-1591	15-1594 15-1594 15-1596 — 15-1591	16-3215-3 16-3215 16-3255-23 — —	52-2075 52-2050 52-2041-6 — 52-20511	— — — — —	— — — — —	— — — — —	— — — — —
A3-54-103 A3-54-270 A3-55-270 A4-5-270 A4-6-270	15-1596 15-1596 15-1596 15-1591 15-1591	15-1623-2 15-1623-2 15-1623-2 15-1591 15-1591	16-3255-23 16-3255-23 16-3255-23 — —	52-2041-6 52-2041-6 52-2041-6 52-2051 52-2051	— — — — —	— — — — —	— — — — —	— — — — —
A4-7-270 A4-18-270 A4-63-110 A4-86-270 A800	15-1666-6 15-1566-6 15-1566-6 15-1566-6 15-1572	15-1566-6 15-1566-6 15-1566-6 15-1566-6 Adapter	— — — — 16-3209	52-2041-6 52-2041-6 52-2041-6 52-2041-6 —	— — — — 11-4177	— — — — 80-4961	— — — — 16-3257-22	— — — — —
AT1226 B7070 B7070B B7070BR B7070R	— 15-1580-4 15-1580-3 15-1580-3 15-1580-4	15-1572 15-1580-4 15-1580-3 15-1580-3 15-1580-4	16-3209 16-3255-16 16-3255-16 16-3255-16 16-3255-16	52-2039 — — — —	— — — — —	— — — — —	— — — — —	— — — — —
B9001B B9001BB B9001BR B9001R B9002B	15-1580-4 15-1580-3 15-1580-3 15-1580-4 15-1580-4	15-1580-4 15-1580-3 15-1580-3 15-1580-4 15-1580-4	16-3255-16 16-3255-16 16-3255-16 16-3255-16 16-3255-16	— — — — —	— — — — —	— — — — —	— — — — —	— — — — —
B9002BB B9002BR B9002R B9021BB thru B9021CR B9022BB thru B9022CR	15-1580-3 15-1580-3 15-1580-4 15-1568 — 15-1568	15-1580-3 15-1580-3 15-1580-4 — — —	16-3255-16 16-3255-16 16-3255-16 16-3203 — 16-3203	— — — — — —	— — — — — —	— — — — — —	— — — — — —	— — — — — —
BR7070 BW9001B BW9001BB BW9001BR BW9001R	15-1580-4 15-1580-4 15-1580-3 15-1580-3 15-1580-3	15-1580-4 15-1580-4 15-1580-3 15-1580-3 15-1580-3	16-3255-16 16-3255-16 16-3255-16 16-3255-16 16-3255-16	— — — — —	— — — — —	— — — — —	— — — — —	— — — — —
BW9002B BW9002BB BW9002BR BW9002R BW9021BB thru BW9021CR	15-1580-4 15-1580-3 15-1580-3 15-1580-3 15-1568	15-1580-4 15-1580-3 15-1580-3 15-1580-3 —	16-3255-16 16-3255-16 16-3255-16 16-3255-16 16-3203	— — — — —	— — — — —	— — — — —	— — — — —	— — — — —
BW9022BB thru BW9022CR C100 Series C200 Series TW3103 TW3113	15-1568 15-1572* 15-1572* 15-1580 15-1580	— Adapter Adapter 15-1580 15-1580	16-3203 16-3209* 16-3209* — —	— — — 52-2043 52-2043	— 11-4177 11-4177 — —	— 80-4961 80-4961 — —	— 16-3257-22 16-3257-22 — —	— — — — —

① Hardware items are sold as replacement parts for Eaton switches only.

*Locking nut 15-1597 and washer 16-3209-2 furnished with black finished devices.

Mounting and Terminal Hardware

Switch Catalog Number	Mounting Hardware ^①				Terminal Hardware ^①			
	Lock Nut	Face Nut	Lock Washer	Locking Ring	Terminal Screws	Terminal Lug or Nut	Lock Washer	Misc. Hardware
TW20000	15-1582	15-1582	16-3202	52-2046	---	---	---	---
TW20001	15-1582	15-1582	16-3202	52-2046	---	---	---	---
TW20002	15-1582	15-1582	16-3202	52-2046	---	---	---	---
W100 Series	15-1572*	Adapter	16-3209*	---	11-4177	80-4961	16-3257-22	---
W1501	15-1573	Adapter	16-3201	---	---	---	---	---
W1501R	15-1573	Adapter	16-3201	---	---	---	---	---
W301	---	15-1577	16-3207	---	---	---	---	---
W302	---	15-1577	16-3207	---	---	---	---	---
W303	---	15-1577	16-3207	---	---	---	---	---
W403P6	15-1572	Adapter	16-3207	---	---	---	---	---
W403P6R	15-1572	Adapter	16-3209	---	---	---	---	---
W9001 thru W9006 Series	15-1572	Adapter	16-3209	52-2042	---	---	---	---
W9601 thru W9606 Series	15-1572	Adapter	16-3209 and 16-3113	---	11-4177	80-4961	16-3257-22	---
W9623 Series	15-1572	Adapter	16-3209 and 16-3113	---	11-4177	80-4961	16-3257-22	---
W150 Series	15-1572*	Adapter	16-3209*	---	---	---	---	---
C20050 Series	---	15-1577	16-3207	---	11-4177	80-4961	16-3257-22	---
C3100 Series	15-1577	15-1577	16-3207	---	11-4177	80-4961	16-3257-22	---
C4100 Series	15-1577	15-1577	16-3207	---	11-4177	80-4961	16-3257-22	---
D201 thru D207 Series	15-1576 or 15-1577 or 15-1579	Adapter	16-3204 or 16-3207 or 16-3210	---	11-4082	---	16-3257-22	---
H11-330	15-1637	15-1637	16-3255-23	52-2041-6	---	---	---	---
H11-331	15-1637	15-1637	16-3255-23	52-2041-6	---	---	---	---
H11-334	15-1637	15-1637	16-3255-23	52-2041-6	---	---	---	---
H11-335	15-1618-2	15-1618-2	16-3209	52-2055	---	---	---	---
H11-374	15-1637	15-1637	16-3255-23	52-2041-6	---	---	---	---
H11-375	15-1718-2	15-1618-2	16-3209	52-2055	---	---	---	---
H11-390	15-1637	15-1637	16-3255-23	52-2041-6	---	---	---	---
H11-391	15-1637	15-1637	16-3255-23	52-2041-6	---	---	---	---
H11-394	15-1637	15-1637	16-3255-23	52-2041-6	---	---	---	---
H11-395	15-1618-2	15-1618-2	16-3209	52-2055	---	---	---	---
H2211	15-1572	Adapter	16-3209	---	---	---	---	---
H2256	15-1572	Adapter	16-3209	---	---	---	---	---
J100	15-1576	Adapter	16-3210	---	11-4177-65	---	16-3257-22	---
J103	15-1576	Adapter	16-3210	---	11-4177-65	---	16-3257-22	---
J20145	---	15-1594	16-3215-3	52-2075	---	---	---	---
J20149	---	15-1594	16-3215-3	52-2075	---	---	---	---
J20152	---	15-1594	16-3215-3	52-2075	---	---	---	---
J20153	---	15-1594	16-3215-3	52-2075	---	---	---	---
J300 Series	15-1572	Adapter	16-3209-3	---	---	---	---	---
J4004	15-1572	Adapter	16-3209	---	---	---	---	---
T1002	---	15-1566	16-3204	52-2041	11-4177-65	---	16-3257-12	---
T1003	---	15-1566	16-3204	52-2041	11-4177-65	---	16-3257-12	---
T1202	---	15-1566	16-3204	52-2041	---	---	---	---
T1203	---	15-1566	16-3204	52-2041	---	---	---	---
T2106	15-1580	15-1580	---	52-2043	---	---	---	---
T2114	15-1580	15-1580	---	52-2043	---	---	---	---
T2150	15-1580	15-1580	---	52-2043	---	---	---	---
T2153	15-1580	15-1580	---	52-2043	---	---	---	---
T3103	15-1580	15-1580	---	52-2043	---	---	---	---
T3106	15-1580	15-1580	---	52-2043	---	---	---	---
T3113	15-1580	15-1580	---	52-2043	---	---	---	---
TW1002	---	15-1566	16-3204	52-2041	11-4177-65	---	16-3257-12	---
TW1003	---	15-1566	16-3204	52-2041	11-4177-65	---	16-3257-12	---
TW2106	15-1580	15-1580	---	52-2043	---	---	---	---
TW2150	15-1580	15-1580	---	52-2043	---	---	---	---
TW2161	15-1580	15-1580	---	52-2043	---	---	---	---

① Hardware items are sold as replacement parts for Eaton switches only.

*Locking nut 15-1597 and washer 16-3209-2 furnished with black finished devices.

ACCESSORIES

Mounting and Terminal Hardware

SELECTION TABLE

MOUNTING HARDWARE FOR ONE HOLE MOUNTING SWITCHES

MOUNTING NUTS							
Size (Inches)	Description	Material	Dimensions (Inches)				Part Number
			Thickness (Dimension "A")	Inside Diameter (Dimension "B")	O.D. or Dim. Across Flats (Dimension "C")	Dim. Across Corners (Dimension "D")	
1/4-40	Hexagon Facenut	Dull nickel plated brass	.063	—	.307	.344	15-454-13
	Hexagon Locknut/Facenut	Cadmium plated brass	.063	—	.309	—	15-1580
	Hexagon Locknut/Facenut	Black plated brass	.063	—	.309	—	15-1580-3
	Hexagon Locknut/Facenut	Cadmium plated steel	.063	—	.309	—	15-1580-4
	Hexagon Locknut/Facenut	Stainless steel-passivated	.094	—	.375	—	15-1591
13/32-32	Hexagon Facenut	Cadmium plated brass	.109	—	.500	—	15-1568
15/32-32	Hexagon Locknut/Facenut	Dull nickel plated steel	.078	—	.563	.656	15-966-6
	Hexagon Facenut	Cadmium plated brass	.078	—	.563	—	15-1566
	Hexagon Locknut/Facenut	Cadmium plated steel	.078	—	.563	—	15-1566-6
	Hexagon Locknut/Facenut	Cadmium plated steel	.093	—	.558	.640	15-1594
	Hexagon Locknut/Facenut	Stainless steel-passivated	.078	—	.563	—	15-1596
	Decorative Facenut	Chrome plated brass	.125	.375	.775	—	15-1623-2
Hexagon Locknut/Facenut	Cadmium plated steel	.125	—	.625	.720	15-1637	
1/2-32	Hexagon Locknut/Facenut	Cadmium plated brass	.140	—	.625	—	15-1577
5/8-18	Hexagon Facenut	Cadmium plated brass	.125	—	.813	—	15-1574
5/8-24	Hexagon Locknut	Tin-zinc plated brass	.094	—	.750	—	15-1572
	Hexagon Locknut/Facenut	Stainless steel-passivated	.125	—	.813	.930	15-1618-2
3/4-32	Hexagon Locknut	Cadmium plated brass	.125	—	1.00	—	15-1573
MOUNTING WASHERS, LOCKING RING AND PANEL SEAL							
1/4 DIA.	Internal Tooth Lockwasher	Stainless steel-passivated	.018	.261	.402	—	16-1751
	Internal Tooth Lockwasher	Cadmium plated steel	.018	.261	.403	—	16-3202
	Internal Tooth Lockwasher	Stainless steel-passivated	.025	.261	.469	—	16-3255-16
	Panel Seal	Silicone Rubber	.035	.295	.372	—	32-239-15
	Locking Ring (tab)	Cadmium plated brass	.031	.252	.344	—	52-2043
	Locking Ring (tab)	Stainless steel-passivated	.031	.260	.476	—	52-2051
	Locking Ring (D-flat)	Stainless steel-passivated	.029	.255	.398	—	52-2046
13/32 DIA.	Internal Tooth Lockwasher	Cadmium plated bronze	.022	.441	.540	—	16-3202
15/32 DIA.	Internal Tooth Lockwasher	Stainless steel-passivated	.018	.476	.600	—	16-886
	Internal Tooth Lockwasher	Stainless steel-passivated	.019	.476	.600	—	16-3255-23
	Internal Tooth Lockwasher	Cadmium plated steel	.018	.472	.594	—	16-3215
	Internal Tooth Lockwasher	Cadmium plated steel	.018	.472	.594	—	16-3215-3
	Internal Tooth Lockwasher	Cadmium plated bronze	.018	.472	.594	—	16-3204
	Locking Ring (tab)	Cadmium plated brass	.040	.475	.719	—	52-2041
	Locking Ring (tab)	Stainless steel-passivated	.040	.475	.719	—	52-2041-6
	Locking Ring (D-flat)	Cadmium plated steel	.048	.470	.719	.446	52-2075
	Locking Ring (tab)	Stainless steel-passivated	.040	.475	.719	—	29-761
	Locking Ring (D-flat)	Stainless steel-passivated	.040	.475	.719	—	52-2050
1/2 DIA.	Internal Tooth Lockwasher	Cadmium plated bronze	.022	.500	.625	—	16-3207
5/8 DIA.	Internal Tooth Lockwasher	Tin-zinc plated bronze	.022	.640	.875	—	16-3209
	Internal Tooth Lockwasher	Nickel plated bronze	.022	.640	.875	—	16-3209-3
	Gasket, washer	Neoprene rubber	.062	.625	.875	—	16-3113
	Locking Ring (tab)	Cadmium plated brass	.031	.631	.938	—	52-2042
	Locking Ring (tab)	Stainless steel-passivated	.040	.652	.875	—	52-2055
3/4 DIA.	Internal Tooth Lockwasher	Stainless steel-passivated	.022	.759	1.063	—	16-3201
7/8 DIA.	Internal Tooth Lockwasher	Cadmium plated bronze	.020	.885	1.095	—	16-3210
TERMINAL HARDWARE - SCREWS, LOCKWASHERS, LUGS AND NUTS							
#6-32 x.250 #6-32 x.187 #6-32 x.187 #2-56 x.130 #6-32 x.190	Terminal Sem screw	Dull nickel plated brass	—	—	—	—	11-2379
	Terminal screw	Dull nickel plated brass	—	—	—	—	11-4082
	Terminal screw	Dull nickel plated brass	—	—	—	—	11-4074
	Terminal screw	Dull nickel plated brass	—	—	—	—	11-4177
	Terminal screw	Dull nickel plated brass	—	—	—	—	11-4177-65
1/4 DIA. 1/4 DIA. 1/4 DIA. 1/4 DIA. 6/32 DIA. 2/56 DIA.	Lockwasher	Nickel plated brass	.064	.265	.500	—	16-421-5
	Lockwasher	Silver plated brass	.040	.275	.562	—	821-1114-6
	Lockwasher	Cadmium plated brass	.062	.259	.489	—	16-3493
	Lockwasher	Cadmium plated bronze	.063	.255	.487	—	16-365-2
	Lockwasher	Cadmium plated bronze	.031	.141	.253	—	16-3257-12
Lockwasher	Cadmium plated bronze	.015	.088	.165	—	16-3257-22	
#2/56 x.130	Terminal Lug	Tin plated brass	—	—	—	—	80-4961
1/4 - 20	Terminal Nut	Silver plated brass	—	—	—	—	815-601-3

Ⓞ Hardware items are sold as replacement parts for Eaton switches only.



REFERENCE DOCUMENTS

Cross Reference

MILITARY PART NUMBERS TO EATON CATALOG NUMBERS

Military Part Number	Eaton Catalog No.	MIL Specification	Military Part Number	Eaton Catalog No.	MIL Specification	Military Part Number	Eaton Catalog No.	MIL Specification
AN3221-1	24-1939	MIL-T-6750	M8805/93-009	A3-200-02	MIL-S-8805/93	MS21026-C231	8855K7	MIL-S-8834
-2	19-1939-2	MIL-T-6750	-010	-03	MIL-S-8805/93	-D211	K10	MIL-S-8834
AN3223-1	8864K2	MIL-B-5423	-011	-04	MIL-S-8805/93	-E221	K14	MIL-S-8834
-2	49-2033-2	MIL-B-5423	-012	-05	MIL-S-8805/93	-E231	K8	MIL-S-8834
AN3230-1	8780K11	MIL-S-6745	-013	-06	MIL-S-8805/93	-F271	K15	MIL-S-8834
-2	8781K11	MIL-S-6745	-014	-07	MIL-S-8805/93	-G311	K16	MIL-S-8834
-3	8782K11	MIL-S-6745	-015	A3-202-01	MIL-S-8805/93	-H271	K17	MIL-S-8834
E1663-1	8790K4	XEL37	-016	-02	MIL-S-8805/93	-J241	K9	MIL-S-8834
-3	8792K3	XEL37	-017	-03	MIL-S-8805/93	-K281	K18	MIL-S-8834
M3950/14A21	8546K1	MIL-S-3950	-018	-04	MIL-S-8805/93	-K311	K20	MIL-S-8834
A22	K9	MIL-S-3950	-019	-05	MIL-S-8805/93	-L311	K12	MIL-S-8834
A23	K4	MIL-S-3950	-020	A3-202-06	MIL-S-8805/93	MS21027-A211	8856K4	MIL-S-8834
A24	K6	MIL-S-3950	-021	-07	MIL-S-8805/93	-A331	K21	MIL-S-8834
A25	K8	MIL-S-3950	-022	A3-204-01	MIL-S-8805/93	-A711	K4X	MIL-S-8834
A26	K5	MIL-S-3950	-023	-02	MIL-S-8805/93	-A831	K21X	MIL-S-8834
A27	K2	MIL-S-3950	-024	-03	MIL-S-8805/93	-B211	K5	MIL-S-8834
A28	K7	MIL-S-3950	-025	A3-204-04	MIL-S-8805/93	-B241	K19	MIL-S-8834
A29	K10	MIL-S-3950	-026	-05	MIL-S-8805/93	-B331	K30	MIL-S-8834
A30	K11	MIL-S-3950	-027	-06	MIL-S-8805/93	-B711	K5X	MIL-S-8834
A31	K3	MIL-S-3950	-028	-07	MIL-S-8805/93	-B741	K19X	MIL-S-8834
A32	K12	MIL-S-3950	M8805/95-001	B7070	MIL-S-8805/95	-B831	K30X	MIL-S-8834
A33	K13	MIL-S-3950	-002	B7070R	MIL-S-8805/95	-C221	K13	MIL-S-8834
B21	8547K1	MIL-S-3950	-003	B7070B	MIL-S-8805/95	-C231	K7	MIL-S-8834
B22	K9	MIL-S-3950	-004	B7070BR	MIL-S-8805/95	-C331	K31	MIL-S-8834
B23	K4	MIL-S-3950	M8805/96-001	B9001R	MIL-S-8805/96	-C721	K13X	MIL-S-8834
B24	K6	MIL-S-3950	-002	B9001B	MIL-S-8805/96	-C731	K7X	MIL-S-8834
B25	K8	MIL-S-3950	-003	B9002R	MIL-S-8805/96	-C831	K31X	MIL-S-8834
B26	K5	MIL-S-3950	-004	B9002B	MIL-S-8805/96	-D211	K10	MIL-S-8834
B27	K2	MIL-S-3950	-005	B9001BR	MIL-S-8805/96	-D331	K32	MIL-S-8834
B28	K7	MIL-S-3950	-006	B9001BB	MIL-S-8805/96	-D711	K10X	MIL-S-8834
B29	K10	MIL-S-3950	-007	B9002BR	MIL-S-8805/96	-D831	K32X	MIL-S-8834
B30	K11	MIL-S-3950	-008	B9002BB	MIL-S-8805/96	-E221	K14	MIL-S-8834
B31	K3	MIL-S-3950	-009	BW9001R	MIL-S-8805/96	-E231	K8	MIL-S-8834
B32	K12	MIL-S-3950	-010	BW9001B	MIL-S-8805/96	-E721	K14X	MIL-S-8834
B33	K13	MIL-S-3950	-011	BW9002R	MIL-S-8805/96	-E731	K8X	MIL-S-8834
B34	K15	MIL-S-3950	-012	BW9002B	MIL-S-8805/96	-F341	K22	MIL-S-8834
B35	K16	MIL-S-3950	-013	BW9001BR	MIL-S-8805/96	-F371	K27	MIL-S-8834
B36	K17	MIL-S-3950	-014	BW9001BB	MIL-S-8805/96	-F841	K22X	MIL-S-8834
C21	8548K1	MIL-S-3950	-015	BW9002BR	MIL-S-8805/96	-F871	K27X	MIL-S-8834
C22	8548K9	MIL-S-3950	-016	BW9002BB	MIL-S-8805/96	-G311	K16	MIL-S-8834
C23	K4	MIL-S-3950	M22885/18-01	A20267	MIL-S-22885	-G351	K35	MIL-S-8834
M3950/14C24	8548K6	MIL-S-3950	-02	J20145	MIL-S-22885	-G811	K16X	MIL-S-8834
C25	K8	MIL-S-3950	-03	A20271	MIL-S-22885	-G851	K35X	MIL-S-8834
C26	K5	MIL-S-3950	-04	J20149	MIL-S-22885	-H341	8856K34	MIL-S-8834
C27	K2	MIL-S-3950	-05	A20272	MIL-S-22885	-H371	K29	MIL-S-8834
C28	K7	MIL-S-3950	-06	J20152	MIL-S-22885	-H841	K34X	MIL-S-8834
C29	K10	MIL-S-3950	-07	A20273	MIL-S-22885	-H871	K29X	MIL-S-8834
C30	K11	MIL-S-3950	-08	J20153	MIL-S-22885	-J241	K9	MIL-S-8834
C31	K3	MIL-S-3950	MS14001-212	8836K91	MIL-S-8834	-J741	K9X	MIL-S-8834
C32	K12	MIL-S-3950	-222	K99	MIL-S-8834	-K311	K20	MIL-S-8834
C33	K13	MIL-S-3950	-232	K94	MIL-S-8834	-K321	K24	MIL-S-8834
C34	K15	MIL-S-3950	-242	K96	MIL-S-8834	-K351	K23	MIL-S-8834
C35	K16	MIL-S-3950	-262	K95	MIL-S-8834	-K381	K28	MIL-S-8834
C36	8548K17	MIL-S-3950	-272	K92	MIL-S-8834	-K811	K20X	MIL-S-8834
M5423/16-01	32-341	MIL-B-5423	-282	K97	MIL-S-8834	-K821	K24X	MIL-S-8834
M8805/2	(see MS25085)		-292	K910	MIL-S-8834	-K851	K23X	MIL-S-8834
/4	(see MS24547)		-302	K911	MIL-S-8834	-K881	K28X	MIL-S-8834
/5	(see MS25350)		-312	K93	MIL-S-8834	-L311	K12	MIL-S-8834
/11	(see MS25342)		MS14002-212	8837K91	MIL-S-8834	-L351	K36	MIL-S-8834
/11	(see MS25343)		-222	K99	MIL-S-8834	-L811	K12X	MIL-S-8834
/14	(see MS25345)		-232	K94	MIL-S-8834	-L851	K36X	MIL-S-8834
/14	(see MS25346)		-242	K96	MIL-S-8834	MS21321-1	H11-335	MIL-S-8805/39
/14	(see MS25347)		-262	K95	MIL-S-8834	-2	H11-395	MIL-S-8805/39
/15	(see MS25348)		-272	K92	MIL-S-8834	MS21346-211	8868K51	MIL-S-8834
/15	(see MS25349)		-282	K97	MIL-S-8834	-221	K57	MIL-S-8834
/16	(see MS25351)		-292	K910	MIL-S-8834	-231	K54	MIL-S-8834
/17	(see MS25353)		-302	K911	MIL-S-8834	-241	K55	MIL-S-8834
/18	(see MS25356)		-312	K93	MIL-S-8834	-271	K52	MIL-S-8834
/19	(see MS25357)		MS14003-212	8838K91	MIL-S-8834	-281	K56	MIL-S-8834
/20	(see MS16712)		-222	K99	MIL-S-8834	-311	K53	MIL-S-8834
/38	(see MS27903)		-232	K94	MIL-S-8834	-321	K58	MIL-S-8834
/39	(see MS21321)		-242	K96	MIL-S-8834	-A211	8855K54	MIL-S-8834
/40	(see MS24331)		-262	K95	MIL-S-8834	-B211	K55	MIL-S-8834
/43	(see MS27248)		-272	K92	MIL-S-8834	-B241	K519	MIL-S-8834
/53	(see MS27996)		-282	K97	MIL-S-8834	-C221	K513	MIL-S-8834
M8805/55-001	8870K2	MIL-S-8805/55	-292	K910	MIL-S-8834	-C231	K57	MIL-S-8834
-002	K3	MIL-S-8805/55	-302	K911	MIL-S-8834	-D211	K510	MIL-S-8834
-003	K4	MIL-S-8805/55	-312	K93	MIL-S-8834	-E221	K514	MIL-S-8834
-004	K5	MIL-S-8805/55	MS16712-1	C20050	MIL-S-8805/20	-E231	K58	MIL-S-8834
M8805/93-001	A3-212-01	MIL-S-8805/93	MS16712-2	C20050R	MIL-S-8805/20	-F271	K515	MIL-S-8834
-002	-02	MIL-S-8805/93	MS18150-1	TW20001	MIL-S-83731	-G311	K516	MIL-S-8834
-003	-03	MIL-S-8805/93	MS18151-1	TW20002	MIL-S-83731	-H271	K517	MIL-S-8834
-004	-04	MIL-S-8805/93	MS18152-1	TW20000	MIL-S-83731	-J241	K59	MIL-S-8834
-005	-05	MIL-S-8805/93	MS21026-A211	8855K4	MIL-S-8834	-K281	K518	MIL-S-8834
-006	-06	MIL-S-8805/93	-B211	K5	MIL-S-8834	-K311	K520	MIL-S-8834
-007	-07	MIL-S-8805/93	-B241	K19	MIL-S-8834	-L311	K512	MIL-S-8834
-008	A3-200-01	MIL-S-8805/93	-C221	K13	MIL-S-8834			

MILITARY PART NUMBERS TO EATON CATALOG NUMBERS

Military Part Number	Eaton Catalog No.	MIL Specification	Military Part Number	Eaton Catalog No.	MIL Specification	Military Part Number	Eaton Catalog No.	MIL Specification
MS21347-211	8869K51	MIL-S-8834	MS21357-221	8869K67	MIL-S-8834	MS21437-H341	8856K734	MIL-S-8834
-821	K58X	MIL-S-8834	-231	K64	MIL-S-8834	-H371	K729	MIL-S-8834
-831	K59X	MIL-S-8834	-241	K65	MIL-S-8834	-H841	K734X	MIL-S-8834
-841	K511X	MIL-S-8834	-271	K62	MIL-S-8834	-H871	K729X	MIL-S-8834
-851	K510X	MIL-S-8834	-281	K66	MIL-S-8834	-J241	K79	MIL-S-8834
-A211	8856K54	MIL-S-8834	-311	K63	MIL-S-8834	-J741	K79X	MIL-S-8834
-A331	K521	MIL-S-8834	-321	K68	MIL-S-8834	-K311	K720	MIL-S-8834
-B211	K55	MIL-S-8834	-331	K69	MIL-S-8834	-K321	K724	MIL-S-8834
-B241	K519	MIL-S-8834	-341	K611	MIL-S-8834	-K351	K723	MIL-S-8834
-B331	K530	MIL-S-8834	-351	K610	MIL-S-8834	-K381	K728	MIL-S-8834
-C221	K513	MIL-S-8834	MS21357-711	8869K61X	MIL-S-8834	-K811	K720X	MIL-S-8834
-C231	K57	MIL-S-8834	-721	K67X	MIL-S-8834	-K821	K724X	MIL-S-8834
-C331	K531	MIL-S-8834	-731	K64X	MIL-S-8834	-K851	K723X	MIL-S-8834
-D211	K510	MIL-S-8834	-741	K65X	MIL-S-8834	-K881	K728X	MIL-S-8834
-D331	K532	MIL-S-8834	-771	K62X	MIL-S-8834	-L311	K712	MIL-S-8834
-E221	K514	MIL-S-8834	-781	K66X	MIL-S-8834	-L351	K736	MIL-S-8834
-E231	K58	MIL-S-8834	-811	K63X	MIL-S-8834	-L811	K712X	MIL-S-8834
-F271	K515	MIL-S-8834	-821	K68X	MIL-S-8834	-L851	K736X	MIL-S-8834
-F341	K522	MIL-S-8834	-831	K69X	MIL-S-8834	MS24331-1	H11-375	MIL-S-8805/40
-F371	K527	MIL-S-8834	-841	K611X	MIL-S-8834	MS24417-1	8492K1	MIL-G-7703
-G311	K516	MIL-S-8834	-851	K610X	MIL-S-8834	MS24523-21	8500K1	MIL-S-3950
-G351	K535	MIL-S-8834	MS21433-211	8866KA61	MIL-S-8834	-22	K9	MIL-S-3950
-H271	K517	MIL-S-8834	-221	KA67	MIL-S-8834	-23	K4	MIL-S-3950
-H341	K534	MIL-S-8834	-231	KA64	MIL-S-8834	-24	K6	MIL-S-3950
-H371	K529	MIL-S-8834	-241	KA65	MIL-S-8834	-25	K8	MIL-S-3950
-J241	K59	MIL-S-8834	-271	KA62	MIL-S-8834	-26	K5	MIL-S-3950
-K281	K518	MIL-S-8834	-281	KA66	MIL-S-8834	-27	K2	MIL-S-3950
-K311	K520	MIL-S-8834	-311	KA63	MIL-S-8834	-28	K7	MIL-S-3950
-K321	K524	MIL-S-8834	-321	KA68	MIL-S-8834	-29	K10	MIL-S-3950
-K351	K523	MIL-S-8834	MS21434-211	8867KA61	MIL-S-8834	-30	K11	MIL-S-3950
-K381	K528	MIL-S-8834	-221	KA67	MIL-S-8834	-31	K3	MIL-S-3950
-L311	K512	MIL-S-8834	-231	KA64	MIL-S-8834	-32	K12	MIL-S-3950
-L351	K536	MIL-S-8834	-241	KA65	MIL-S-8834	-33	K13	MIL-S-3950
-221	8869K57	MIL-S-8834	-271	KA62	MIL-S-8834	MS24524-21	8501K1	MIL-S-3950
-231	K54	MIL-S-8834	-281	KA66	MIL-S-8834	-22	K9	MIL-S-3950
-241	K55	MIL-S-8834	-311	KA63	MIL-S-8834	-23	K4	MIL-S-3950
-271	K52	MIL-S-8834	-321	KA68	MIL-S-8834	-24	K6	MIL-S-3950
-281	K56	MIL-S-8834	-331	KA69	MIL-S-8834	-25	K8	MIL-S-3950
-311	K53	MIL-S-8834	-341	KA611	MIL-S-8834	-26	K5	MIL-S-3950
-321	K58	MIL-S-8834	-351	KA610	MIL-S-8834	-27	K2	MIL-S-3950
-331	K59	MIL-S-8834	MS21436-A211	8855K74	MIL-S-8834	-28	K7	MIL-S-3950
-341	K511	MIL-S-8834	-B211	K75	MIL-S-8834	-29	K10	MIL-S-3950
-351	K510	MIL-S-8834	-B241	K719	MIL-S-8834	-30	K11	MIL-S-3950
-711	K51X	MIL-S-8834	-C221	K713	MIL-S-8834	-31	K3	MIL-S-3950
-721	K57X	MIL-S-8834	-C231	K77	MIL-S-8834	-32	K12	MIL-S-3950
-731	K54X	MIL-S-8834	-D211	K710	MIL-S-8834	-33	K13	MIL-S-3950
-741	K55X	MIL-S-8834	-E221	K714	MIL-S-8834	MS24525-21	8502K1	MIL-S-3950
-771	K52X	MIL-S-8834	-E231	K78	MIL-S-8834	-22	K9	MIL-S-3950
-781	K56X	MIL-S-8834	-F271	K715	MIL-S-8834	-23	K4	MIL-S-3950
-811	K53X	MIL-S-8834	-G11	K716	MIL-S-8834	-24	K6	MIL-S-3950
MS21351-321	8868K8	MIL-S-8834	-H271	K717	MIL-S-8834	-25	K8	MIL-S-3950
MS21353-321	8869K8	MIL-S-8834	-J241	K79	MIL-S-8834	-26	K5	MIL-S-3950
-331	K9	MIL-S-8834	-K281	K718	MIL-S-8834	-27	K2	MIL-S-3950
-341	K11	MIL-S-8834	-K311	K720	MIL-S-8834	-28	K7	MIL-S-3950
-351	K10	MIL-S-8834	-L311	K712	MIL-S-8834	-29	K10	MIL-S-3950
-821	K8X	MIL-S-8834	MS21437-A211	8856K74	MIL-S-8834	-30	K11	MIL-S-3950
-831	K9X	MIL-S-8834	-A331	K721	MIL-S-8834	-31	K3	MIL-S-3950
-841	K11X	MIL-S-8834	-A711	8856K74X	MIL-S-8834	-32	K12	MIL-S-3950
-851	K10X	MIL-S-8834	-A831	K21X	MIL-S-8834	-33	K13	MIL-S-3950
MS21354-211	8866K61	MIL-S-8834	-B211	K75	MIL-S-8834	MS24547-1	SS30AT40	MIL-S-8805/4
-221	K67	MIL-S-8834	-B241	K719	MIL-S-8834	-2	KT40	MIL-S-8805/4
-231	K64	MIL-S-8834	-B331	K730	MIL-S-8834	-3	DT40	MIL-S-8805/4
-241	K65	MIL-S-8834	-B711	K75X	MIL-S-8834	-4	AT41	MIL-S-8805/4
-271	K62	MIL-S-8834	-B741	K719X	MIL-S-8834	-5	KT41	MIL-S-8805/4
-281	K66	MIL-S-8834	-B831	K730X	MIL-S-8834	MS24612-A212	8843K1	MIL-S-8834
-311	K63	MIL-S-8834	-C221	K713	MIL-S-8834	-B212	K2	MIL-S-8834
-321	K68	MIL-S-8834	-C231	K77	MIL-S-8834	-B242	K16	MIL-S-8834
MS21355-211	8867K61	MIL-S-8834	-C331	K731	MIL-S-8834	-C212	K3	MIL-S-8834
-221	K67	MIL-S-8834	-C721	K713X	MIL-S-8834	-C222	K9	MIL-S-8834
-231	K64	MIL-S-8834	-C731	K77X	MIL-S-8834	-C232	K7	MIL-S-8834
-241	K65	MIL-S-8834	-C831	K731X	MIL-S-8834	-D212	K4	MIL-S-8834
-271	K62	MIL-S-8834	-D211	K710	MIL-S-8834	-E212	K5	MIL-S-8834
-281	K66	MIL-S-8834	-D331	K732	MIL-S-8834	-E222	K10	MIL-S-8834
-311	K63	MIL-S-8834	-D711	K710X	MIL-S-8834	-E232	K6	MIL-S-8834
-321	K68	MIL-S-8834	-D831	K732X	MIL-S-8834	-F272	K12	MIL-S-8834
-331	K69	MIL-S-8834	-E221	K714	MIL-S-8834	-G312	K13	MIL-S-8834
-341	K611	MIL-S-8834	-E231	K78	MIL-S-8834	-H272	K14	MIL-S-8834
-351	K610	MIL-S-8834	-E721	K714X	MIL-S-8834	-J242	K11	MIL-S-8834
MS21356-211	8868K61	MIL-S-8834	-E731	K78X	MIL-S-8834	-K282	K15	MIL-S-8834
-221	K67	MIL-S-8834	-F341	K722	MIL-S-8834	-K312	K18	MIL-S-8834
-231	K64	MIL-S-8834	-F371	K727	MIL-S-8834	-L262	K20	MIL-S-8834
-241	K65	MIL-S-8834	-F841	K722X	MIL-S-8834	-L292	K21	MIL-S-8834
-271	K62	MIL-S-8834	-F871	K727X	MIL-S-8834	-L302	K19	MIL-S-8834
-281	K66	MIL-S-8834	-G311	K716	MIL-S-8834	-M312	K8	MIL-S-8834
-311	K63	MIL-S-8834	-G351	K735	MIL-S-8834	-N312	K17	MIL-S-8834
-321	K68	MIL-S-8834	-G811	K716X	MIL-S-8834	MS24613-A212	8844K1	MIL-S-8834
MS21357-211	8869K61	MIL-S-8834	-G851	K735X	MIL-S-8834	-B212	K2	MIL-S-8834

Cross Reference

MILITARY PART NUMBERS TO EATON CATALOG NUMBERS

Military Part Number	Eaton Catalog No.	MIL Specification	Military Part Number	Eaton Catalog No.	MIL Specification	Military Part Number	Eaton Catalog No.	MIL Specification
MS24613-B242	8844K16	MILS-8834	MS24658-21L	8503K32	MILS-3950	MS24660-21P	8505K34	MILS-3950
-C212	K3	MILS-8834	-21M	K33	MILS-3950	K10	K10	MILS-3950
-C222	K9	MILS-8834	-21N	K4	MILS-3950	-22F	K35	MILS-3950
-C232	K7	MILS-8834	-21P	K34	MILS-3950	-22G	K9	MILS-3950
-D212	K4	MILS-8834	-22D	K10	MILS-3950	-23D	K6	MILS-3950
-E212	K5	MILS-8834	-22F	K35	MILS-3950	-23F	K36	MILS-3950
-E222	K10	MILS-8834	-22G	K9	MILS-3950	-23G	K7	MILS-3950
-E232	K6	MILS-8834	-23D	K6	MILS-3950	-24E	K16	MILS-3950
-F272	K12	MILS-8834	-23F	K36	MILS-3950	-24F	K37	MILS-3950
-G312	K13	MILS-8834	-23G	K7	MILS-3950	-24K	K38	MILS-3950
-H272	K14	MILS-8834	-24E	K16	MILS-3950	-24M	K11	MILS-3950
-J242	K11	MILS-8834	-24F	K37	MILS-3950	-25F	K22	MILS-3950
-K282	K15	MILS-8834	-24K	K38	MILS-3950	-26F	K20	MILS-3950
-K312	K18	MILS-8834	-24M	K11	MILS-3950	-27E	K12	MILS-3950
-L262	K20	MILS-8834	-25F	K22	MILS-3950	-27L	K39	MILS-3950
-L292	K21	MILS-8834	-26F	K20	MILS-3950	-27N	K14	MILS-3950
-L302	K19	MILS-8834	-27E	K12	MILS-3950	-28E	K15	MILS-3950
-M312	K8	MILS-8834	-27L	K39	MILS-3950	-29F	K21	MILS-3950
-N312	K17	MILS-8834	-27N	K14	MILS-3950	-30F	K19	MILS-3950
MS24614-A212	8845K1	MILS-8834	-28E	K15	MILS-3950	-31E	K18	MILS-3950
-B212	K2	MILS-8834	-29F	K21	MILS-3950	-31F	K40	MILS-3950
-B242	K16	MILS-8834	-30F	K19	MILS-3950	-31K	K41	MILS-3950
-C212	K3	MILS-8834	-31E	K18	MILS-3950	-31L	K13	MILS-3950
-C222	K9	MILS-8834	-31F	K40	MILS-3950	-31M	K17	MILS-3950
-C232	K7	MILS-8834	-31K	K41	MILS-3950	-31N	K8	MILS-3950
-D212	K4	MILS-8834	-31L	K13	MILS-3950	-32E	K23	MILS-3950
-E212	K5	MILS-8834	-31M	K17	MILS-3950	-33E	K24	MILS-3950
-E222	K10	MILS-8834	-31N	K8	MILS-3950	-33F	K25	MILS-3950
-E232	K6	MILS-8834	-32E	K23	MILS-3950	-33K	K26	MILS-3950
-F272	K12	MILS-8834	-33E	K24	MILS-3950	-33M	K42	MILS-3950
-G312	K13	MILS-8834	-33F	K25	MILS-3950	MS25081-4	29-761	MILS-3950
-H272	K14	MILS-8834	-33K	K26	MILS-3950	MS25082-8	15-404-6	MILS-83731
-J242	K11	MILS-8834	-33M	K42	MILS-3950	MS25085-1	E4-270	MILS-8805/2
-K282	K15	MILS-8834	MS24659-21A	8504K1	MILS-3950	MS25085-2	E4-271	MILS-8805/2
-K312	K18	MILS-8834	-21B	K27	MILS-3950	MS25214-1	8494K1	MILS-7703
-L262	K20	MILS-8834	-21D	K5	MILS-3950	-2	K2	MILG-7703
-L292	K21	MILS-8834	-21E	K2	MILS-3950	-3	K3	MILG-7703
-L302	K19	MILS-8834	-21F	K28	MILS-3950	MS25221-1	8495K1	MILG-7703
-M312	K8	MILS-8834	-21G	K3	MILS-3950	MS25223-1	8496K1	MILG-7703
-N312	K17	MILS-8834	-21H	K29	MILS-3950	-2	K2	MILG-7703
MS24655-211	8866K1	MILS-8834	-21J	K30	MILS-3950	MS25224-1	8497K1	MILG-7703
-221	K7	MILS-8834	-21K	K31	MILS-3950	-2	K2	MILG-7703
-231	K4	MILS-8834	-21L	K32	MILS-3950	-3	K3	MILG-7703
-241	K5	MILS-8834	-21M	K33	MILS-3950	MS25225-1	8498K1	MILG-7703
-271	K2	MILS-8834	-21N	K4	MILS-3950	-2	K2	MILG-7703
-281	K6	MILS-8834	-21P	K34	MILS-3950	-3	K3	MILG-7703
-311	K3	MILS-8834	-22D	K10	MILS-3950	MS25246-1	24-1164-2	MILB-5423
-321	K8	MILS-8834	-22F	K35	MILS-3950	MS25301-1	49-1740-2	MILB-5423
-211W	K51	MILS-8834	-22G	K9	MILS-3950	MS25306-212	8836K1	MILS-8834
-221W	K57	MILS-8834	-23D	K6	MILS-3950	-222	K9	MILS-8834
-231W	K54	MILS-8834	-23F	K36	MILS-3950	-232	K4	MILS-8834
-241W	K55	MILS-8834	-23G	K7	MILS-3950	-242	K6	MILS-8834
-271W	K52	MILS-8834	-24E	K16	MILS-3950	-262	K5	MILS-8834
-281W	K56	MILS-8834	-24F	K37	MILS-3950	-272	K2	MILS-8834
-311W	K53	MILS-8834	-24K	K38	MILS-3950	-282	K7	MILS-8834
-321W	K58	MILS-8834	-24M	K11	MILS-3950	-292	K10	MILS-8834
MS24656-211	8867K1	MILS-8834	-25F	K22	MILS-3950	-302	K11	MILS-8834
-221	K7	MILS-8834	-26F	K20	MILS-3950	-312	K3	MILS-8834
-231	K4	MILS-8834	-27E	K12	MILS-3950	MS25307-212	8837K1	MILS-8834
-241	K5	MILS-8834	-27L	K39	MILS-3950	-222	K9	MILS-8834
-271	K2	MILS-8834	-27N	K14	MILS-3950	-232	K4	MILS-8834
-281	K6	MILS-8834	-28E	K15	MILS-3950	-242	K6	MILS-8834
-311	K3	MILS-8834	-29F	K21	MILS-3950	-262	K5	MILS-8834
-321	K8	MILS-8834	-30F	K19	MILS-3950	-272	K2	MILS-8834
-331	K9	MILS-8834	-31E	K18	MILS-3950	-282	K7	MILS-8834
-341	K11	MILS-8834	-31F	K40	MILS-3950	-292	K10	MILS-8834
-351	K10	MILS-8834	-31K	K41	MILS-3950	-302	K11	MILS-8834
-211W	K51	MILS-8834	-31L	K13	MILS-3950	-312	K3	MILS-8834
-221W	K57	MILS-8834	-31M	K17	MILS-3950	MS25308-212	8838K1	MILS-8834
-231W	K54	MILS-8834	-31N	K8	MILS-3950	-222	K9	MILS-8834
-241W	K55	MILS-8834	-32E	K23	MILS-3950	-232	K4	MILS-8834
-271W	K52	MILS-8834	-33E	K24	MILS-3950	-242	K6	MILS-8834
-281W	K56	MILS-8834	-33F	K25	MILS-3950	-262	K5	MILS-8834
-311W	K53	MILS-8834	-33K	K26	MILS-3950	-272	K2	MILS-8834
-321W	K58	MILS-8834	-33M	K42	MILS-3950	-282	K7	MILS-8834
-331W	K59	MILS-8834	MS24660-21A	8505K1	MILS-3950	-292	K10	MILS-8834
-341W	K511	MILS-8834	-21B	K27	MILS-3950	-302	K11	MILS-8834
-351W	K510	MILS-8834	-21D	K5	MILS-3950	-312	K3	MILS-8834
MS24658-21A	8503K1	MILS-3950	-21E	K2	MILS-3950	MS25342-1	S1-44	MILS-8805/11
-21B	K27	MILS-3950	-21F	K28	MILS-3950	MS25343-1	S3-44	MILS-8805/11
-21D	K5	MILS-3950	-21G	K3	MILS-3950	MS25344-1	S2-44	MILS-8805/11
-21E	K2	MILS-3950	-21H	K29	MILS-3950	MS25345-1	S1-344	MILS-8805/14
-21F	K28	MILS-3950	-21J	K30	MILS-3950	MS25346-1	S3-344	MILS-8805/14
-21G	K3	MILS-3950	-21K	K31	MILS-3950	MS25347-1	S2-344	MILS-8805/14
-21H	K29	MILS-3950	-21L	K32	MILS-3950	MS25348-1	D4-44	MILS-8805/15
-21J	K30	MILS-3950	-21M	K33	MILS-3950	MS25349-1	D8-44	MILS-8805/15
21K	K31	MILS-3950	-21N	K4	MILS-3950	MS25350-1	D4-344	MILS-8805/5

MILITARY PART NUMBERS TO EATON CATALOG NUMBERS

Military Part Number	Eaton Catalog No.	MIL Specification	Military Part Number	Eaton Catalog No.	MIL Specification	Military Part Number	Eaton Catalog No.	MIL Specification
MS25351-1	D8-344	MIL-S-8805/16	MS27722-21	8570K1-16	MIL-S-3950	MS27781-33M	8573K42-16	MIL-S-3950
MS25353-1	K3-344	MIL-S-8805/17	-22	K9-16	MIL-S-3950	MS27782-1A	8575K65-16	MIL-S-3950
MS25356-1	K3-44	MIL-S-8805/18	-23	K4-16	MIL-S-3950	-1B	K66-16	MIL-S-3950
MS25357-1	G3-44	MIL-S-8805/19	-24	K6-16	MIL-S-3950	-1D	K67-16	MIL-S-3950
MS25452-1	8499K1	MIL-G-7703	-25	K8-16	MIL-S-3950	-1E	K68-16	MIL-S-3950
MS27240-1	H11-330	MIL-S-8805/43	-26	K5-16	MIL-S-3950	-1F	K69-16	MIL-S-3950
-2	-390	MIL-S-8805	-27	K2-16	MIL-S-3950	-1G	K70-16	MIL-S-3950
-3	-331	MIL-S-8805/43	-28	K7-16	MIL-S-3950	-1H	K71-16	MIL-S-3950
-4	-391	MIL-S-8805	-29	K10-16	MIL-S-3950	-1J	K72-16	MIL-S-3950
MS27259-1	H11-334	MIL-S-8805	-30	K11-16	MIL-S-3950	-1K	K73-16	MIL-S-3950
-2	-394	MIL-S-8805	-31	K3-16	MIL-S-3950	-1L	K74-16	MIL-S-3950
MS27406-1	8502K15	MIL-S-3950	-32	K12-16	MIL-S-3950	-1M	K75-16	MIL-S-3950
-2	K16	MIL-S-3950	-33	K13-16	MIL-S-3950	-1N	K76-16	MIL-S-3950
-3	K17	MIL-S-3950	MS27723-1	8571K17-16	MIL-S-3950	-1P	K77-16	MIL-S-3950
MS27407-1	8501K14	MIL-S-3950	-2	K18-16	MIL-S-3950	-2E	K78-16	MIL-S-3950
-2	K15	MIL-S-3950	-3	K19-16	MIL-S-3950	-2F	K79-16	MIL-S-3950
-3	K16	MIL-S-3950	-21	K1-16	MIL-S-3950	-2K	K80-16	MIL-S-3950
-4	K17	MIL-S-3950	-22	K9-16	MIL-S-3950	-2L	K81-16	MIL-S-3950
-5	K18	MIL-S-3950	-23	K4-16	MIL-S-3950	-2M	K82-16	MIL-S-3950
-6	K19	MIL-S-3950	-24	K6-16	MIL-S-3950	-2N	K83-16	MIL-S-3950
MS27408-1A	8504K43	MIL-S-3950	-25	K8-16	MIL-S-3950	MS27782-3E	8574K84-16	MIL-S-3950
-1B	K44	MIL-S-3950	-26	K5-16	MIL-S-3950	-3L	K85-16	MIL-S-3950
-1D	K45	MIL-S-3950	-27	K2-16	MIL-S-3950	-3N	K86-16	MIL-S-3950
-1E	K46	MIL-S-3950	-28	K7-16	MIL-S-3950	-21A	K1-16	MIL-S-3950
-1F	K47	MIL-S-3950	-29	K10-16	MIL-S-3950	-21B	K27-16	MIL-S-3950
-1G	K48	MIL-S-3950	-30	K11-16	MIL-S-3950	-21D	K5-16	MIL-S-3950
-1H	K49	MIL-S-3950	-31	K3-16	MIL-S-3950	-21E	K2-16	MIL-S-3950
-1J	K50	MIL-S-3950	-32	K12-16	MIL-S-3950	-21F	K28-16	MIL-S-3950
-1K	K51	MIL-S-3950	-33	K13-16	MIL-S-3950	-21G	K3-16	MIL-S-3950
-1L	K52	MIL-S-3950	MS27724-1	8572K15-16	MIL-S-3950	-21H	K29-16	MIL-S-3950
-1M	K53	MIL-S-3950	-2	K16-16	MIL-S-3950	-21J	K30-16	MIL-S-3950
-1N	K54	MIL-S-3950	-3	K17-16	MIL-S-3950	-21K	K31-16	MIL-S-3950
-1P	K55	MIL-S-3950	-21	K1-16	MIL-S-3950	-21L	K32-16	MIL-S-3950
-2E	K56	MIL-S-3950	-22	K9-16	MIL-S-3950	-21M	K33-16	MIL-S-3950
-2F	K57	MIL-S-3950	-23	K4-16	MIL-S-3950	-21N	K4-16	MIL-S-3950
-2K	K58	MIL-S-3950	-24	K6-16	MIL-S-3950	-21P	K34-16	MIL-S-3950
-2L	K59	MIL-S-3950	-25	K8-16	MIL-S-3950	-22D	K10-16	MIL-S-3950
-2M	K60	MIL-S-3950	-26	K5-16	MIL-S-3950	-22F	K35-16	MIL-S-3950
-2N	K61	MIL-S-3950	-27	K2-16	MIL-S-3950	-22G	K9-16	MIL-S-3950
-3E	K62	MIL-S-3950	-28	K7-16	MIL-S-3950	-23D	K6-16	MIL-S-3950
-3L	K63	MIL-S-3950	-29	K10-16	MIL-S-3950	-23F	K36-16	MIL-S-3950
-3N	K64	MIL-S-3950	-30	K11-16	MIL-S-3950	-23G	K7-16	MIL-S-3950
-4A	8504K65	MIL-S-3950	-31	K3-16	MIL-S-3950	-24E	K16-16	MIL-S-3950
-4B	K66	MIL-S-3950	-32	K12-16	MIL-S-3950	-24F	K37-16	MIL-S-3950
-4D	K67	MIL-S-3950	-33	K13-16	MIL-S-3950	-24K	K38-16	MIL-S-3950
-4E	K68	MIL-S-3950	MS27752-1	8498K6	MIL-G-7703	-24M	K11-16	MIL-S-3950
-4F	K69	MIL-S-3950	MS27781-21A	8573K1-16	MIL-S-3950	-25F	K22-16	MIL-S-3950
-4G	K70	MIL-S-3950	-21B	K27-16	MIL-S-3950	-26F	K20-16	MIL-S-3950
-4H	K71	MIL-S-3950	-21D	K5-16	MIL-S-3950	-27E	K12-16	MIL-S-3950
-4J	K72	MIL-S-3950	-21E	K2-16	MIL-S-3950	-27L	K39-16	MIL-S-3950
-4K	K73	MIL-S-3950	-21F	K28-16	MIL-S-3950	-27N	K14-16	MIL-S-3950
-4L	K74	MIL-S-3950	-21G	K3-16	MIL-S-3950	-28E	K15-16	MIL-S-3950
-4M	K75	MIL-S-3950	-21H	K29-16	MIL-S-3950	-29F	K21-16	MIL-S-3950
-4N	K76	MIL-S-3950	-21J	K30-16	MIL-S-3950	-30F	K19-16	MIL-S-3950
-4P	K77	MIL-S-3950	-21K	K31-16	MIL-S-3950	-31E	K18-16	MIL-S-3950
-5E	K78	MIL-S-3950	-21L	K32-16	MIL-S-3950	-31F	K40-16	MIL-S-3950
-5F	K79	MIL-S-3950	-21M	K33-16	MIL-S-3950	-31K	K41-16	MIL-S-3950
-5K	K80	MIL-S-3950	-21N	K4-16	MIL-S-3950	-31L	K13-16	MIL-S-3950
-5L	K81	MIL-S-3950	-21P	K34-16	MIL-S-3950	-31M	K17-16	MIL-S-3950
-5M	K82	MIL-S-3950	-22D	K10-16	MIL-S-3950	-31N	K8-16	MIL-S-3950
-5N	K83	MIL-S-3950	-22F	K35-16	MIL-S-3950	-32E	K23-16	MIL-S-3950
-6E	K84	MIL-S-3950	-22G	K9-16	MIL-S-3950	-33E	K24-16	MIL-S-3950
-6L	K85	MIL-S-3950	-23D	K6-16	MIL-S-3950	-33F	K25-16	MIL-S-3950
-6N	K86	MIL-S-3950	-23F	K36-16	MIL-S-3950	-33K	K26-16	MIL-S-3950
-7B	K87	MIL-S-3950	-23G	K7-16	MIL-S-3950	-33M	K42-16	MIL-S-3950
MS27409-1A	8505K43	MIL-S-3950	-24E	K16-16	MIL-S-3950	MS27783-1A	8575K43-16	MIL-S-3950
-1B	K44	MIL-S-3950	-24F	K37-16	MIL-S-3950	-1B	K44-16	MIL-S-3950
-1D	K45	MIL-S-3950	-24K	K38-16	MIL-S-3950	-1D	K45-16	MIL-S-3950
-1E	K46	MIL-S-3950	-24M	K11-16	MIL-S-3950	-1E	K46-16	MIL-S-3950
-1F	K47	MIL-S-3950	-25F	K22-16	MIL-S-3950	-1K	K51-16	MIL-S-3950
-1G	K48	MIL-S-3950	-26F	K20-16	MIL-S-3950	-1L	K52-16	MIL-S-3950
-1H	K49	MIL-S-3950	-27E	K12-16	MIL-S-3950	-1M	K53-16	MIL-S-3950
-1J	K50	MIL-S-3950	-27L	K39-16	MIL-S-3950	-1N	K54-16	MIL-S-3950
-1K	K51	MIL-S-3950	-27N	K14-16	MIL-S-3950	-1P	K55-16	MIL-S-3950
-1L	K52	MIL-S-3950	-28E	K15-16	MIL-S-3950	-2E	K56-16	MIL-S-3950
-1M	K53	MIL-S-3950	-29F	K21-16	MIL-S-3950	-2F	K57-16	MIL-S-3950
-1N	K54	MIL-S-3950	-30F	K19-16	MIL-S-3950	-2K	K58-16	MIL-S-3950
-1P	K55	MIL-S-3950	-31E	K18-16	MIL-S-3950	-2L	K59-16	MIL-S-3950
-2E	K56	MIL-S-3950	-31F	K40-16	MIL-S-3950	-2M	K60-16	MIL-S-3950
-2F	K57	MIL-S-3950	-31K	K41-16	MIL-S-3950	-2N	K61-16	MIL-S-3950
-2K	K58	MIL-S-3950	-31L	K13-16	MIL-S-3950	-3E	K62-16	MIL-S-3950
-2L	K59	MIL-S-3950	-31M	K17-16	MIL-S-3950	-3L	K63-16	MIL-S-3950
-2M	K60	MIL-S-3950	-31N	K8-16	MIL-S-3950	-3N	K64-16	MIL-S-3950
-2N	K61	MIL-S-3950	-32E	K23-16	MIL-S-3950	-21A	K1-16	MIL-S-3950
-3E	K62	MIL-S-3950	-33E	K24-16	MIL-S-3950	-21B	K27-16	MIL-S-3950
-3L	K63	MIL-S-3950	-33F	K25-16	MIL-S-3950	-21D	K5-16	MIL-S-3950
-3N	K64	MIL-S-3950	-33K	K26-16	MIL-S-3950	-21E	K2-16	MIL-S-3950

REFERENCE DOCUMENTS

Cross Reference

MILITARY PART NUMBERS TO EATON CATALOG NUMBERS

Military Part Number	Eaton Catalog No.	MIL Specification	Military Part Number	Eaton Catalog No.	MIL Specification	Military Part Number	Eaton Catalog No.	MIL Specification
MS27783-21F	8575K28-16	MIL-S-3950	MS27787-21F	8573K8-20	MIL-S-3950	MS27788-27N	8574K14-20	MIL-S-3950
-21G	K3-16	MIL-S-3950	-21G	K3-20	MIL-S-3950	-28E	K15-20	MIL-S-3950
-21H	K29-16	MIL-S-3950	-21H	K29-20	MIL-S-3950	-29F	K21-20	MIL-S-3950
-21J	K30-16	MIL-S-3950	-21J	K30-20	MIL-S-3950	-30F	K19-20	MIL-S-3950
-21K	K31-16	MIL-S-3950	-21K	K31-20	MIL-S-3950	-31E	K18-20	MIL-S-3950
-21L	K32-16	MIL-S-3950	-21L	K32-20	MIL-S-3950	-31F	K40-20	MIL-S-3950
-21M	K33-16	MIL-S-3950	-21M	K33-20	MIL-S-3950	-31K	K41-20	MIL-S-3950
-21N	K4-16	MIL-S-3950	-21N	K4-20	MIL-S-3950	-31L	K13-20	MIL-S-3950
-21P	K34-16	MIL-S-3950	-21P	K34-20	MIL-S-3950	-31M	K17-20	MIL-S-3950
-22D	K10-16	MIL-S-3950	-22D	K10-20	MIL-S-3950	-31N	K8-20	MIL-S-3950
-22F	K35-16	MIL-S-3950	-22F	K35-20	MIL-S-3950	-32E	K23-20	MIL-S-3950
-22G	K9-16	MIL-S-3950	-22G	K9-20	MIL-S-3950	-33E	K24-20	MIL-S-3950
-23D	K6-16	MIL-S-3950	-23D	K6-20	MIL-S-3950	-33F	K25-20	MIL-S-3950
-23F	K36-16	MIL-S-3950	-23F	K36-20	MIL-S-3950	-33G	K26-20	MIL-S-3950
-23G	K7-16	MIL-S-3950	-23G	K7-20	MIL-S-3950	-33M	K42-20	MIL-S-3950
-24E	K16-16	MIL-S-3950	-24E	K16-20	MIL-S-3950	MS27789-1A	8575K43-20	MIL-S-3950
-24F	K37-16	MIL-S-3950	-24F	K37-20	MIL-S-3950	-1B	K44-20	MIL-S-3950
-24K	K38-16	MIL-S-3950	-24K	K38-20	MIL-S-3950	-1D	K45-20	MIL-S-3950
-24M	K11-16	MIL-S-3950	-24M	K11-20	MIL-S-3950	-1E	K46-20	MIL-S-3950
-25F	K22-16	MIL-S-3950	-25F	K22-20	MIL-S-3950	-1F	K47-20	MIL-S-3950
-26F	K20-16	MIL-S-3950	-26F	K20-20	MIL-S-3950	-1G	K48-20	MIL-S-3950
-27E	K12-16	MIL-S-3950	-27E	K12-20	MIL-S-3950	-1H	K49-20	MIL-S-3950
-27L	K39-16	MIL-S-3950	-27L	K39-20	MIL-S-3950	-1J	K50-20	MIL-S-3950
-27N	K14-16	MIL-S-3950	-27N	K14-20	MIL-S-3950	-1K	K51-20	MIL-S-3950
-28E	K15-16	MIL-S-3950	-28E	8573K15-20	MIL-S-3950	-1L	K52-20	MIL-S-3950
-29F	K21-16	MIL-S-3950	-29F	K21-20	MIL-S-3950	-1M	K53-20	MIL-S-3950
-30F	K19-16	MIL-S-3950	-30F	K19-20	MIL-S-3950	-1N	K54-20	MIL-S-3950
-31E	K18-16	MIL-S-3950	-31E	K18-20	MIL-S-3950	-1P	K55-20	MIL-S-3950
-31F	K40-16	MIL-S-3950	-31F	K40-20	MIL-S-3950	-2E	K56-20	MIL-S-3950
-31K	K41-16	MIL-S-3950	-31K	K41-20	MIL-S-3950	-2F	K57-20	MIL-S-3950
-31L	K13-16	MIL-S-3950	-31L	K13-20	MIL-S-3950	-2K	K58-20	MIL-S-3950
-31M	K17-16	MIL-S-3950	-31M	K17-20	MIL-S-3950	-2L	K59-20	MIL-S-3950
-31N	K8-16	MIL-S-3950	-31N	K8-20	MIL-S-3950	-2M	K60-20	MIL-S-3950
-32E	K23-16	MIL-S-3950	-32E	K23-20	MIL-S-3950	-2N	K61-20	MIL-S-3950
-33E	K24-16	MIL-S-3950	-33E	K24-20	MIL-S-3950	-3E	K62-20	MIL-S-3950
-33F	K25-16	MIL-S-3950	-33F	K25-20	MIL-S-3950	-3L	K63-20	MIL-S-3950
-33K	K26-16	MIL-S-3950	-33K	K26-20	MIL-S-3950	-3N	K64-20	MIL-S-3950
-33M	K42-16	MIL-S-3950	-33M	K42-20	MIL-S-3950	-21A	K1-20	MIL-S-3950
MS27784-21	8570K1-20	MIL-S-3950	MS27788-1A	8574K65-20	MIL-S-3950	-21B	K27-20	MIL-S-3950
-22	K9-20	MIL-S-3950	-1B	K66-20	MIL-S-3950	-21D	K5-20	MIL-S-3950
-23	K4-20	MIL-S-3950	-1D	K67-20	MIL-S-3950	-21E	K2-20	MIL-S-3950
-24	K6-20	MIL-S-3950	-1E	K68-20	MIL-S-3950	-21F	K28-20	MIL-S-3950
-25	K8-20	MIL-S-3950	-1F	K69-20	MIL-S-3950	-21G	K3-20	MIL-S-3950
-26	K5-20	MIL-S-3950	-1G	K70-20	MIL-S-3950	-21H	K29-20	MIL-S-3950
-27	K2-20	MIL-S-3950	-1H	K71-20	MIL-S-3950	-21J	K30-20	MIL-S-3950
-28	K7-20	MIL-S-3950	-1J	K72-20	MIL-S-3950	-21K	K31-20	MIL-S-3950
-29	K10-20	MIL-S-3950	-1K	K73-20	MIL-S-3950	-21L	K32-20	MIL-S-3950
-30	K11-20	MIL-S-3950	-1L	K74-20	MIL-S-3950	-21M	8575K33-20	MIL-S-3950
-31	K3-20	MIL-S-3950	-1M	K75-20	MIL-S-3950	-21N	K4-20	MIL-S-3950
-32	K12-20	MIL-S-3950	-1N	K76-20	MIL-S-3950	-21P	K34-20	MIL-S-3950
-33	K13-20	MIL-S-3950	-1P	K77-20	MIL-S-3950	-22D	K10-20	MIL-S-3950
MS27785-1	8571K17-20	MIL-S-3950	-2E	K78-20	MIL-S-3950	-22F	K35-20	MIL-S-3950
-2	K18-20	MIL-S-3950	-2F	K79-20	MIL-S-3950	-22G	K9-20	MIL-S-3950
-3	K19-20	MIL-S-3950	-2K	K80-20	MIL-S-3950	-23D	K6-20	MIL-S-3950
-21	K1-20	MIL-S-3950	-2L	K81-20	MIL-S-3950	-23F	K36-20	MIL-S-3950
-22	K9-20	MIL-S-3950	-2M	K82-20	MIL-S-3950	-23G	K7-20	MIL-S-3950
-23	K4-20	MIL-S-3950	-2N	K83-20	MIL-S-3950	-24E	K18-20	MIL-S-3950
-24	K6-20	MIL-S-3950	-3E	K84-20	MIL-S-3950	-24F	K37-20	MIL-S-3950
-25	K8-20	MIL-S-3950	-3L	K85-20	MIL-S-3950	-24K	K38-20	MIL-S-3950
-26	K5-20	MIL-S-3950	-3N	K86-20	MIL-S-3950	-24M	K11-20	MIL-S-3950
-27	K2-20	MIL-S-3950	-21A	K1-20	MIL-S-3950	-25F	K22-20	MIL-S-3950
-28	K7-20	MIL-S-3950	-21B	K27-20	MIL-S-3950	-26F	K20-20	MIL-S-3950
-29	K10-20	MIL-S-3950	-21D	K5-20	MIL-S-3950	-27E	K12-20	MIL-S-3950
-30	K11-20	MIL-S-3950	-21E	K2-20	MIL-S-3950	-27L	K39-20	MIL-S-3950
-31	K3-20	MIL-S-3950	-21F	K28-20	MIL-S-3950	-27N	K14-20	MIL-S-3950
-32	K12-20	MIL-S-3950	-21G	K3-20	MIL-S-3950	-28E	K15-20	MIL-S-3950
-33	K13-20	MIL-S-3950	-21H	K29-20	MIL-S-3950	-29F	K21-20	MIL-S-3950
MS27786-1	8572K15-20	MIL-S-3950	-21J	K30-20	MIL-S-3950	-30F	K19-20	MIL-S-3950
-2	K16-20	MIL-S-3950	-21K	K31-20	MIL-S-3950	-31E	K18-20	MIL-S-3950
-3	K17-20	MIL-S-3950	-21L	K32-20	MIL-S-3950	-31F	K40-20	MIL-S-3950
-21	K1-20	MIL-S-3950	-21M	K33-20	MIL-S-3950	-31K	K41-20	MIL-S-3950
-22	K9-20	MIL-S-3950	-21N	K4-20	MIL-S-3950	-31L	K13-20	MIL-S-3950
-23	K4-20	MIL-S-3950	-21P	K34-20	MIL-S-3950	-31M	K17-20	MIL-S-3950
-24	K6-20	MIL-S-3950	-22D	K10-20	MIL-S-3950	-31N	K8-20	MIL-S-3950
-25	K8-20	MIL-S-3950	-22F	K35-20	MIL-S-3950	-32E	K23-20	MIL-S-3950
-26	K5-20	MIL-S-3950	-22G	K9-20	MIL-S-3950	-33E	K24-20	MIL-S-3950
-27	K2-20	MIL-S-3950	-23D	K6-20	MIL-S-3950	-33F	K25-20	MIL-S-3950
-28	K7-20	MIL-S-3950	-23F	K36-20	MIL-S-3950	-33K	K26-20	MIL-S-3950
-29	K10-20	MIL-S-3950	-23G	K7-20	MIL-S-3950	-33M	K42-20	MIL-S-3950
-30	K11-20	MIL-S-3950	-24E	K16-20	MIL-S-3950	MS27903-1	WC150PB6	MIL-S-8805/38
-31	K3-20	MIL-S-3950	-24F	K37-20	MIL-S-3950	-2	WC150PB6R	MIL-S-8805/38
-32	K12-20	MIL-S-3950	-24K	K38-20	MIL-S-3950	-3	WC150PAB6	MIL-S-8805/38
-33	K13-20	MIL-S-3950	-24M	K11-20	MIL-S-3950	-4	WC150PAB6R	MIL-S-8805/38
MS27787-21A	8573K1-20	MIL-S-3950	-25F	K22-20	MIL-S-3950	-5	WC150WB6	MIL-S-8805/38
-21B	K27-20	MIL-S-3950	-26F	K20-20	MIL-S-3950	-6	WC150WB6R	MIL-S-8805/38
-21D	K5-20	MIL-S-3950	-27E	K12-20	MIL-S-3950	MS27994-1	SF203	MIL-S-8805/32
-21E	K2-20	MIL-S-3950	-27L	K39-20	MIL-S-3950	-2	-206	MIL-S-8805/32

MILITARY PART NUMBERS TO EATON CATALOG NUMBERS

Military Part Number	Eaton Catalog No.	MIL Specification
-3	-103	MIL-S-8805/32
-4	-203-1	MIL-S-8805/32
-5	-206-1	MIL-S-8805/32
MS27995-1	H11-228	MIL-S-8805/42
MS27996-1	H6-1029	MIL-S-8805/53
MS90310-211	8868K1	MIL-S-8834
-221	K7	MIL-S-8834
-231	K4	MIL-S-8834
-241	K5	MIL-S-8834
-271	K2	MIL-S-8834
-281	K6	MIL-S-8834
-311	K3	MIL-S-8834
MS90311-211	8869K1	MIL-S-8834
-221	K7	MIL-S-8834
-231	K4	MIL-S-8834
-241	K5	MIL-S-8834
-271	K2	MIL-S-8834
-281	K6	MIL-S-8834
-311	K3	MIL-S-8834
-711	K1X	MIL-S-8834
-721	K7X	MIL-S-8834
-731	K4X	MIL-S-8834
-741	K5X	MIL-S-8834
-771	K2X	MIL-S-8834
-781	K6X	MIL-S-8834
-811	K3X	MIL-S-8834
NAF1173-1	8896K1	
-2	8895K1	
NAF1174-1	8897K1	
NAF47851-1	8499K2	

REFERENCE DOCUMENTS

Rating, Cross Reference and Engineering Data

MIL Specifications				
TEST REQUIREMENT	MIL SPECIFICATION			
	MIL-S-8805	MIL-S-22885	MIL-S-3950F	MIL-S-8834F
1. Strength of Terminal	Solder - 9 lb. #4 Screw - 5 lb. #6 Screw - 30 lb. Leads - 15 lb.	Solder - 5 lb. #4 Screw - 5 lb. #6 Screw - 30 lb. Leads - 15 lb.	5 lb. solder lug. 25 lb. screw term. 5 lb. in. torque screw term. 15 lb. I.W.T.S. term.	5 lb. solder lug 25 lb. screw term. 5 lb. in. torque screw term. 5 lb. I.W.T.S. term.
2. Strength of Actuating Lever Pivot and Stop	10 lb.	25 lb.	25 lb. throughout range	25 lb. throughout range
3. Strength of Mounting Means	15 lb.-in.	15 lb.-in.	25 lb.-in. torque	65 lb.-in. torque 15/32 & over 15 lb.-in. torque under 15/32
4. Dielectric (Sea Level) Indication	1000V ac for one minute	1000V ac for one minute	1200V ac Group A 750V ac after electrical endurance toggle to terminal only. 500 A max. leakage 500V ac (65K ft.)	1800V ac Group A 500 A max. leakage 500V ac (65K ft.)
Dielectric (Altitude)	500V ac above 10,000 ft.	400V ac above 10,000 ft.	500 A max. leakage 500V ac (65K ft.)	
5. Contact Voltage Drop	Contact Resistance .025 Ohm New .040 Ohm After Mechanical Life	Contact Resistance .025 Ohm New .080 Ohm After Electrical Life	2.5 millivolt initial 5.0 millivolt after mechanical endurance I.W.T.S. 8.0 millivolt initial @2-6Vdc 0.1 amp.	1.0 millivolt initial @ 2-6V dc 0.1 amp.
6. Temperature Rise	50 deg. C max. at rated resistive load after life	50 deg. C max. at rated resistive load after life	50 deg. C rise @ rated res. after endurance test current	50 deg. C rise @ rated res. after endurance test current
7. Short Circuit	60 times rated resistive load	60 times rated resistive load	10 oper. make & carry 60 x rated resistive load @ lowest dc V	10 oper. make & carry 60 x rated resistive load @ lowest dc V
8. Mechanical Life	As specified at high and low temperature		20K operations -65 deg. C 20K operations +71 deg. C	20K operations -55 deg. C 20K operations +71 deg. C
9. Electrical Endurance	As specified	As specified	20K operations	20K operations
10. Overload	50 operations @ 150% rated resistive load	50 operations @ 150% rated resistive load	50 operations @ 150% rated resistive load	50 operations @ 150% rated resistive load
11. A) Electrical Endurance at Altitude	Sequence of test, ratings and environmental conditions are specified in MIL-S-8805	Sequence of test, ratings and environmental conditions are specified in MIL-S-22885	20K oper. resistive load @65K ft. rm temp 20K oper. ind. load @65K ft. rm. temp. Performed on separate test samples	20K oper. resistive load @65K ft. rm temp 20K oper. ind. load @65K ft. rm. temp. Performed on separate test samples 20K operations resistive load @ rm. temp.
B) Electrical Endurance at Sea Level			20K operations resistive load @71 deg. C 20K operations ind. load @ rm. temp. Performed on separate test samples	20K operations ind. load @ rm. temp. Performed on separate test samples
12. Vibration	See Detail Sheet	See Detail Sheet	Method 204 of MIL-STD-202. Test Condition A .06 D.A. or 10 G's 10-500 Hz 10 sec. max. chatter	Method 204 of MIL-STD-202. Test Condition D .06 D.A. or 20 G's 2000 Hz 10 sec. max. chatter
13. Shock	See Detail Sheet	See Detail Sheet	Pulse-Method 213 of MIL-STD-202, Test Condition B @ 75 G's 10 sec. max. chatter	Pulse-Method 213 of MIL-STD-202, Test Condition I @ 100G's 10 sec. max. chatter
14. Salt Spray Test Upon Completion	MIL-STD-202 Method 101 See Detail Sheet	MIL-STD-202 Method 101 See Detail Sheet	48 hours-Method 101 of MIL-STD-202, Test Condition B 10 operations @ lowest rated dc voltage	96 hours-Method 101 of MIL-STD-202, Test Condition A Env. 50 oper. @ rated resistive current and lowest rated dc V
15. Moisture Resistance	MIL-STD-202 Method 106, 100V dc potential between current carrying parts & panel	MIL-STD-202 Method 106, 100V dc potential between current carrying parts & panel	Method 106 of MIL-STD-202 10 days, 100V dc potential between current carrying parts & panel	Method 106 of MIL-STD-202, 10 days, 100V dc potential between current carrying parts & panel, 0.1 A. max. leakage

Rating, Cross Reference and Engineering Data

MIL Specifications - Continued

TEST REQUIREMENT	MIL SPECIFICATION			
	MIL-S-8805	MIL-S-22885	MIL-S-3950F	MIL-S-8834F
16. Sand & Dust	See Detail Sheet	See Detail Sheet	Method 110 of MIL-STD-202, Test Cond. B; 6 hrs @ 23 deg. C; 6 hrs @ 63 deg. C. 2.5K oper. mechanical life	Method 110 of MIL-STD-202, Test Cond. B; 6 hours @ 23 deg. C, 6 hrs @ 63 deg. C. 2.5K oper. mechanical life.
17. Explosion	MIL-STD-202 Method 109	MIL-STD-202 Method 109	No Requirement	Method 109 of MIL-STD-202. Max. rated dc inductive load toggle seal only.
18. Sealing	See Detail Sheet	See Detail Sheet	1) Non destructive-submerge in H2O @ 2.0 +/- .5 in. of Hg for 5 minutes 2) Destructive-no leakage when sub-merged in sodium chloride solution at 2.0 +/- .5 in. of Hg for 4 hrs and sub merged at sea level for 16 hours	1) Lever seal - 20K operations at 6.5 lbs./in2 water pressure - seal only submerged 1/4" bushings only ③ 2) Environmental seal: A-Non dest.-mass spectr. B-Destructive-submerge sw. in ethylene glycol, temp. range -18 deg. C to +71 deg. C, 20K oper. Sws. checked for contact V drop & dielectric
19. A) Toggle Seal B) Bushing Seal	---	---	No Requirement See Sealing	1 hr ea. lever pos. @-55 deg C Toggle ICE
20. Temperature Operation	See Detail Sheet	-55 deg. C to +85 deg. C	See Mechanical Life	See Mechanical Life
21. Life Low Cur. Level	See Detail Sheet	See Detail Sheet	40K operations @25 deg. C; Method 311 of MIL-STD-202 when specified	20K operations @71 deg. C; 5 millivolt, 5 microamp
22. Fungus	Non-nutrient materials only	Non-nutrient materials only	No Requirement	No Requirement
23. Intermediate Current	See Detail Sheet	27 +3 -OV dc & Relay M5757/10-033	20K operations @35-40 mA res.load. Lowest rated dc V and 71 deg. C amb.	See Life Low Cur. Level
24. Thermal Shock	MIL-STD-202 Method 107	MIL-STD-202 Method 107	Method 107 of MIL-STD-202, Test Condition B; 5 cycles @ -65 deg. C/ +125 deg. C	Method 107 of MIL-STD-202, Test Cond. A, 5 cycles @ -55 deg. C/+85 deg. C

③ Toggle seal - 5 operations under 0.5 inches of H2O above top of bushing

Glossary of Terms

-A-

ACTUATOR - Mechanism of the switch that when operated transfers the internal contacts.

ALLOY - A metal composed of two or more different metals to obtain a desired physical property.

ALTERNATE ACTION - Typically associated with pushbutton switches; switch contacts remain in a given circuit condition after removal of actuating force; when actuating force is applied a second time, the opposite circuit is engaged.

ALTERNATING CURRENT (AC) - An electric current that reverses direction at regularly recurring intervals of time.

AMBIENT TEMPERATURE RANGE - Operating temperature range.

ANGLE OF THROW - Associated with rocker and toggle switches to indicate the total travel arc of the actuator, measured in degrees.

ANNEALED - To heat and then cool (as steel or glass) for softening and making the material less brittle; for example, annealed copper is less brittle.

ARCING - The flow or movement of electric current between opening or closing switch contacts.

-B-

BASIC SWITCH - Classified as a self-contained switching unit. May be used independently or with a gang-mounted assembly. Usually mechanically actuated.

BREAK - To open an electrical set of closed contacts.

BREAK BEFORE MAKE - To interrupt one circuit of a pole before completing a second circuit of the same pole.

-C-

CAPACITIVE LOAD - A lumped capacitance that is switched as a unit.

CONTACT BOUNCE - The repeated rebounding of the movable contact during the transfer from one throw to the next; typically measured in micro or milliseconds.

CONTACT RESISTANCE - The resistance measured across a pair of closed contacts, which is in series with the load. Resistance levels will increase over time based on usage load conditions and environment. Measured in milliohms.

CREEPAGE - The unwanted flow of electrical current from one conductive part to another.

CURRENT - The flow of electrons within a wire or a circuit; measured in amperes.

CYCLE - An interval of time during which a sequence of a recurring succession of events or phenomena is completed.

-D-

DETENT - A mechanical positioning device designed to stop the actuator travel at each successive electrical circuit.

DIELECTRIC STRENGTH - The potential gradient at which electric failure or breakdown occurs.

DIFFERENTIAL TRAVEL (D.T.) - The amount of actuator or plunger travel measured from the point where contacts "snap over" to the point where they "snap back."

DIRECT CURRENT (DC) - A unidirectional current in which changes in value are either zero or so small that they may be neglected. As originally used, the term designates a practically non-pulsating current.

DOUBLE BREAK CONTACTS - (Twin break.) Switch circuit breaks in two places. Also referred to as form Z circuitry.

DOUBLE POLE (DP) - see Pole.

DOUBLE-POLE DOUBLE-THROW (DPDT) - Switches which make and break two separate circuits. Both normally open and normally closed set of contacts offered with each pole.

DOUBLE THROW (DT) - see Throw.

DRY CIRCUIT - A low energy circuit condition where no arcing occurs during contact switching; typically in millivolt and milliamp ranges of current and voltage.

-F-

FLASH PLATING - A very thin or "instant plating" process usually measuring less than 10 micro-inches thick.

FLUX - A substance (such as rosin) applied to surfaces to be joined by soldering, brazing or welding to clean and free them from oxide and promoting their union.

FREE POSITION (F.P.) - Switch plunger or actuator position when no outside force is applied, other than gravity.

FULL OVERTRAVEL FORCE - The amount of force required to achieve full overtravel of the switch actuator.

-G-

GROUND - A conducting path between an electric circuit or equipment and the earth, or some large conducting body serving in place of the earth whether the connection is intentional or accidental.

-H-

HERMETICALLY SEALED SWITCH - A switch in a gas tight enclosure that has been completely sealed by fusion or comparable means to insure a low rate of gas leakage over a long period of time. All junctures made with glass-to-metal or metal-to-metal.

-I-

INDUCTIVE LOAD - A load in which the initial current on make (contact closing) is lower than steady state and the voltage is greater than steady state upon break (contact opening). When contacts are opened (break), the stored energy of the inductor combined with the long arcing time is severe on the switch contacts.

INRUSH - The amount of current that a load draws when initially closing the switch contacts. May cause severe degradation of contacts.

INSULATION RESISTANCE - The electrical resistance between two normally insulated parts.

IP - Part of the IEC529 standard recommending the degree of protection of enclosures for low-voltage switch gear. Deals with the prevention of ingress of liquids and solid foreign matter in enclosures.

ISOLATED LAMP CIRCUIT - Independent of switching circuit; lamp is operated on a completely separate circuit from the switch circuit.

-L-

LAMP LOAD - Upon initial contact closure (make), high inrush current occurs (approximately 10 times greater than the steady state).

LATCHDOWN - One type of alternate action in which the push-button is mechanically secured in the down position; the pushbutton is at "normal" position for one circuit and latched down position for the other circuit condition.

LED (LIGHT EMITTING DIODE) - A solid state diode that provides variable light.

LOGIC LEVEL - An application in which power levels do not cause arcing, melting, or softening of contacts; also referred to as dry circuit or low energy; typically requiring gold contacts for reliability.

-M-

MAINTAINED ACTION - To remain in a given circuit condition until actuated into the next circuit condition.

MAKE BEFORE BREAK - Completing one circuit of a pole before interrupting another of the same pole.

MOMENTARY ACTION - Mechanically returning from a temporary circuit condition to the maintained circuit condition as soon as the actuating force is removed.

-N-

NC - Normally Closed contacts; circuit is closed when actuator is in its normal at-rest position.

NEMA - National Electrical Manufacturers Association, an agency of the United States, setting standards for products distributed worldwide; applied to switches in their degrees of protection

against the intrusion of liquids, dust, and other contaminants.

NO - Normally Open contacts; circuit is open when actuator is in its normal or at-rest position.

NOISE, ELECTRICAL - Unwanted electrical signals that produce undesirable effects in the circuits of the control systems in which they occur.

NOMINAL - The result of the calculated actual value range.

NONSHORTING CONTACTS - Contacts which break before make.

-O-

OPAQUE - A condition that is not pervious to radiant energy and especially light.

OPERATING FORCE (O.F.) - A measured amount of force applied to switch plunger or actuator to cause contact "snap-over" to occur.

OPERATING POSITION (O.P.) - Position of switch plunger or actuator at which point the internal switch contacts snap from normal to operated position.

OVERTRAVEL (O.T.) - Switch plunger or actuator travel designed to go safely beyond the operating position.

-P-

PANEL SEAL - Prevents liquids and solid particles from reaching the switch contacts from the front of the panel if the panel is subjected to foreign contamination usually caused by spills or splashing.

PARALLEL CIRCUIT - Electrical circuit having two or more inductors or paths for the current to flow.

PF - Power Factor; a means of determining contact capability when used with inductive loads relative to the standard resistive load rating; for example, if PF = 1.0, the inductive load is 100% of the resistive load, or if PF = 0.6, the inductive load is 60% of the resistive load.

POLE - A single common electrical input having one or more outputs.

POSITION - The mechanical stops or detents associated with the switch actuator.

PRECISION SNAP-ACTING SWITCH - An electromechanical switch having predetermined and accurately controlled characteristics and having a spring-loaded quick make and break contact action.

PRETRAVEL (P.T.) - Measured travel associated with the moving of the plunger or actuator from free position to operating position.

PUSH-PUSH - Considered a form of alternate action, but is not latchdown.

Glossary of Terms

-R-

RELEASE FORCE (R.F.) - Amount of force still applied to switch plunger or actuator at moment contacts snap from operated position to unoperated position.

RMS - Root Mean Square.

-S-

SHORTING CONTACTS - Electrical switch contacts that are designed to make before break.

SILICONE RUBBER - Rubber produced from silicone elastomers with a high amount of flexibility, resilience, and tensile strength over a wide temperature range.

SNAP ACTION - Very fast mechanical transfer of contacts from one position to another. Contact transfer action is independent of speed of actuator travel.

SPST - Single Pole Single Throw - see Pole; also Throw.

-T-

TACTILE FEEDBACK - The switching action felt by an operator as he operates the switch from position to position.

THROW - The number of electrical circuits within a switch pole.

TOTAL TRAVEL - Combined distance of actuator pretravel and overtravel; total distance actuator moves from relaxed position past the point of electrical contact and to the end of travel.

TRANSLUCENT - Transmitting and diffusing light so that objects beyond cannot be seen clearly.

TRANSPARENT - Having the property of transmitting light without appreciably scattering so that objects lying beyond are entirely visible.

TRAVEL - The distance the switch actuator moves which causes a change of electrical circuits.

TWO CIRCUIT - Circuit in which one circuit is made in one position and a separate circuit is made in the other position.

-V-

VOLTAGE DROP - The difference of voltages at the two terminals of a passive impedance.

-W-

WIPING ACTION - The action caused by the movable switch contact sliding across the stationary contact, resulting in the cleaning of the contact surfaces.