



Mil-Spec Backshells and Connector Accessories



United States ■ United Kingdom ■ Germany ■ France ■ Nordic ■ Italy ■ Spain

An Important Notice for All Buyers of Military Standard Cylindrical Connector Backshells

SAE Aerospace has assumed control of the M85049 specification for cylindrical connector backshells and accessories.

All existing M85049 specification documents are now superseded by the new AS85049 standard. For convenience in ordering however, basic part numbering for these components will still utilize the familiar M85049 prefix. In other words, only the ID of the controlling specifica-

tion documentation will convert to SAE nomenclature; individual slash sheet part numbers will maintain their original M85049 order numbers.

In addition to the above change, several new specification slash sheets have been added to the AS85049 family of cylindrical backshells for Mil-Spec connectors. Glenair will supply the following new products just as soon as the formal SAE qualification process is completed.

AS85049/103	Straight, Composite, Strain-Relief EMI/RFI Backshell
AS85049/104	45°, Composite, Strain-Relief EMI/RFI Backshell
AS85049/105	90°, Composite, Strain-Relief EMI/RFI Backshell
AS85049/109	Straight, EMI/RFI Shield Sock AS85049 Fig. 4
AS85049/111	90°, EMI/RFI Shield Sock AS85049 Fig. 4
AS85049/112	Straight, EMI/RFI Shield Sock AS85049 Fig. 2
AS85049/114	90°, EMI/RFI Shield Sock AS85049 Fig. 2
AS85049/115	Straight, EMI/RFI Shield Sock AS85049 Fig. 3
AS85049/117	90°, EMI/RFI Shield Sock AS85049 Fig. 3
AS85049/118	Straight, Strain-Relief, Full-Radius Entry AS85049 Fig. 4
AS85049/120	90°, Strain-Relief, Full-Radius Entry AS85049 Fig. 4
AS85049/121	Straight, Strain-Relief, Full-Radius Entry AS85049 Fig. 2
AS85049/123	90°, Strain-Relief, Full-Radius Entry AS85049 Fig. 2
AS85049/124	Straight, Strain-Relief, Full-Radius Entry AS85049 Fig. 3
AS85049/126	90°, Strain-Relief, Full-Radius Entry AS85049 Fig. 3
AS85049/127	Bushing Strip for AS85049 Clamps
AS85049/12	Band, Shield Termination
AS85049/130	Square Flange Gasket
AS85049/131	Straight, Fiber Optic Backshell for AS5590/1 Connector
AS85049/132	45°, Fiber Optic Backshell for AS5590/1 Connector
AS85049/133	90°, Fiber Optic Backshell for AS5590/1 Connector

Military Standard Backshells and Connector Accessories

Potting Boot Rings



Section 30

Environmental Backshells



Section 37

Crimp Rings and Banding Backshells



Section 44

Dummy Storage Receptacles

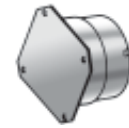

Section 65

Shrink Boot Adapters



Section 31

EMI/RFI Non-Environmental Backshells



Section 38

Qwik-Ty® Strain Reliefs



Section 45

Protective Covers



Section 66

Adapters and Extenders



Section 32

EMI/RFI Environmental Backshells

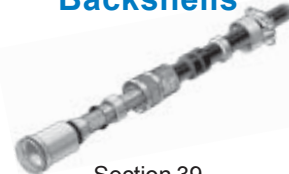

Section 39

Rectangular Backshells



Section 50

Miscellaneous Accessories

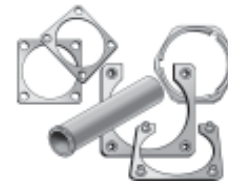

Section 68

Non-Environmental Strain Relief Backshells



Section 36

TAG® Rings and TAG® Ring Backshells



Section 40



Section 60

“E” Nuts



Section 61

Strain Reliefs



Section 62

Conduit and Conduit Accessories

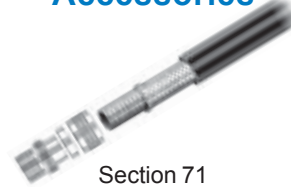

Section 71



Table of Contents		Page
Product Selection Guide		3
Quick Page Reference by Part Number		7
Standard Materials and Notes		8
Recommended Torque Values		9
Military Standard Connector Index		10
Section 30	Potting Boot Rings	30-1
Section 31	Shrink Boot Adapters	31-1
Section 32	Adapters/Extenders	32-1
Section 36	Non-Environmental Strain Relief Backshells	36-1
Section 37	Environmental Backshells	37-1
Section 38	EMI/RFI Non-Environmental Backshells	38-1
Section 39	EMI/RFI Environmental Backshells	39-1
Section 40	TAG® Rings and TAG® Ring Backshells	40-1
Section 44	Crimp Ring and Banding Backshells	44-1
Section 45	Qwik-Ty® Strain Reliefs	45-1
Section 50	Rectangular Backshells	50-1
Section 60	Tools	60-1
Section 61	"E" Nuts	61-1
Section 62	Strain Reliefs	62-1
Section 65	Dummy Stowage Receptacles	65-1
Section 66	Protective Covers	66-1
Section 68	Miscellaneous Accessories (Jam Nuts, Potting Boots, Bushings, Fiber Optic Terminus)	68-1
Section 71	Conduit/Convuluted Tubing and Related Adapters and Fittings	71-1
Appendix A	Part Number Index	A-1

The following product type descriptions are provided as an aid in selecting the proper accessory for each functional requirement. Please use the part number index A to find the catalog page for a specific Mil-Spec accessory slash number.

Section 30 - Potting Boot Rings



Potting Boot Rings are designed for use with M85049/74 and /75 potting boots. The plastic potting boots snap in place to provide an easy and convenient receptacle for cable sealing potting material.

Section 31 - Shrink Boot Adapters

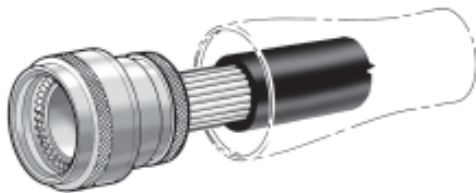

The adapters in this section are designed to accommodate lipped-type heat shrinkable boots, which are used for both mechanical strain relief and a degree of environmental protection.

Section 32 - Adapters/Extenders



Simple straight backshells which provide for thread adaptations or extensions behind the connector.

Section 36 - Non-Environmental Strain Relief Backshells



Straight backshells are combined with a variety of strain reliefs to provide cable to connector protection in situations where environmental sealing is not required.

Section 37 - Environmental Backshells



Glenair Environmental Backshells offer excellent immersion capability when used with impervious jacketed cables. A resilient grommet which fits into a counterbore in the backshell compresses and seals against the cable jacket when the strain relief is tightened.

Section 38 - EMI/RFI Non-Environmental Backshells



A choice of 360° shield/screen terminations are offered in straight and angled backshells, and include designs to accommodate combinations of individual or overall shields or screens. All designs included in this section provide low dc resistance across the termination area.

Section 39 - EMI/RFI Environmental Backshells



The backshells described in this section have EMI/RFI shield/screen terminations with cable sealing or environmental resisting features. Straight and angled designs are available.

Section 40 - TAG[®] Rings and TAG[®] Ring Backshells

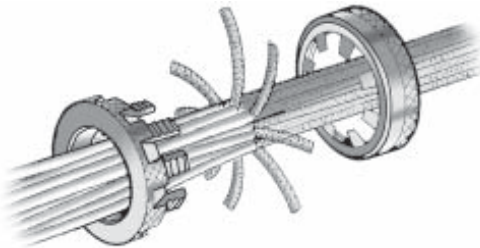

Glenair's TAG[®] Ring backshells offer a unique and reliable method of terminating individually shielded wires where the shields are to be grounded through the backshell and connector shell. No special tools are required for assembly and full maintainability is provided.

Section 44 - Crimp Ring and Banding Backshells



Banding and crimp ring backshells provide an economical approach to terminating overall cable and harness shields/screens. These backshells utilize standard bands or crimp rings for full 360° shield/screen termination with the lowest dc resistance available.

Section 45 - Qwik-Ty® Strain Reliefs



Glenair's Qwik-Ty® strain reliefs offer a unique method of providing strain relief to open wire bundles used with circular connectors. The Qwik-Ty® provides a low profile, reduced weight and simple installation. Installation is quick and secure, using either plastic tie straps or lacing tape.

Section 50 - Rectangular Backshells



Glenair's selection of rectangular backshells provide strain relief and environmental protection for rack and panel style connectors.

Section 60 - Tools



Mil-Spec Connector wrenches, plug and receptacle holders and accessories are required for expert assembly of interconnect systems. Glenair manufactures a wide range of connector wrenches and other assembly tools. Contact Glenair or your local sales representative for a copy of the *Glenair Backshell Assembly Tools, Banding Tools and Accessories* catalog.

Section 61 - "E" Nuts



This section describes the various backshells without strain relief for use with circular connectors. (These are most commonly referred to as "E" Nuts.)

Section 62 - Strain Reliefs



Glenair offers a comprehensive selection of strain reliefs for circular connectors. Straight and angular versions are offered for most connector series.

Section 65 - Dummy Stowage Receptacles

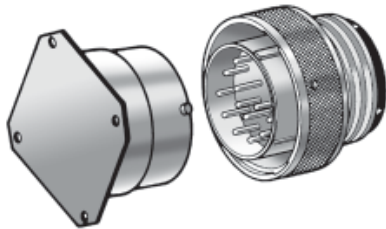

A choice of dummy stowage receptacles is offered for most circular bayonet coupled and threaded coupled connectors.

Section 66 - Protective Covers



A wide selection of protective covers are offered for almost all bayonet or threaded coupled circular connectors. Glenair's proprietary versions (as shown in Glenair's *Circular Connector Accessories* catalog) offer a broad choice of attachments not provided on the Military Standard versions. EMI/RFI protective covers are offered for most bayonet coupled receptacle connectors.

Section 68 - Miscellaneous Accessories

Can't find it anywhere else? Try this selection of miscellaneous connector accessories. Included in this section are Jam Nuts, Potting Boots, Gaskets, Bushings, and Fiber Optic Terminus.

Section 71 - Conduit and Conduit Accessories



Glenair's M24758 Series conduit and associated fittings have been tested and qualified in accordance with MIL-C-4758 (SH). Glenair's M24758 products are designed to shield cables from electromagnetic radiation, electromagnetic pulse, and to provide weatherproofing. Glenair's M24758 Series products offer the highest level of performance and quality while providing a field-installable and cost-effective conduit system.

Quick Page Reference by Part Number
 (A more detailed index of Mil-Spec part numbers
 is located at the end of this catalog)



General
Information

Part Number	Page	Part Number	Page	Part Number	Page	Part Number	Page
GP2000	71-41	MS27293	66-11	M81511/14 CD	38-2	M85049/32-1	68-10
RP2000	71-41	MS27294	66-10	M81511/16	61-3	M85049/32-2	68-11
MS3057A	62-13	MS27295	66-11	M81511/17	66-9	M85049/33-1	68-12
MS3057B	62-9	MS27296	65-11	M81511/18	66-9	M85049/33-2	44-4
MS3057C	62-10	MS27297	65-11	M81511/19	65-9	M85049/34	32-3
MS3057D	62-14	MS27342-2	62-19*	M81511/29	66-9	M85049/36	38-14
MS3105	65-2	MS27352	66-6*	M81511/30	65-10	M85049/37	38-15
MS3115	65-3	MS27353	66-6*	M83538/9	32-2	M85049/38	62-11
MS3152	45-4*	MS27485	30-2*	M83723/15A	62-20	M85049/39	62-12
MS3153	45-4*	MS27501	66-5	M83723/15N	61-7	M85049/41	62-13
MS3154	45-4*	MS27502	66-5	M83723/15S	62-22	M85049/42	62-14
MS3158	31-4	MS27506	62-19*	M83723/16M	31-5*	M85049/43	62-15
MS3180	66-2	MS27507	62-18	M83723/27M	31-2	M85049/44	50-3
MS3181	66-2	MS27510	66-6	M83723/35A	36-2	M85049/45	62-16
MS3184	32-3*	MS27511	66-6	M83723/35N	61-4	M85049/46	62-17
MS3186	68-2	MS27512	68-2*	M83723/35S	36-3	M85049/47	62-18
MS3188A	39-10	MS27514	68-2*	M83723/44	66-2*	M85049/48-1	50-4
MS3188B	37-22	MS27558	62-3	M83723/45	65-3*	M85049/48-2	50-5
MS3188C	38-8	MS27559	62-4	M83723/46	66-2*	M85049/48-3	50-6
MS3189A	39-8	MS27668	45-5*	M83723/50	45-2	M85049/49-2	62-19
MS3189B	37-20	MS27669	45-5*	M83723/59-1	66-10	M85049/50	50-7
MS3189C	38-6	MS27670	45-5*	M83723/59-2	66-11	M85049/51	62-20
MS3415	62-15*	MS27741	40-2	M83723/60-1	66-10	M85049/52	62-22
MS3416E	61-7	M28840/1	62-5	M83723/60-2	66-11	M85049/53	45-4
MS3416G	31-5	M28840/2	62-6	M83723/61	65-11	M85049/54	45-4
MS3417	62-22	M28840/3	62-7	M83723/70	68-9	M85049/55	45-4
MS3418	62-20	M28840/4	71-31	M83733/15	50-2	M85049/56	45-5
MS3419	44-3	M28840/5	71-32	M83733/16	50-3	M85049/57	45-5
MS3420	68-4	M28840/6 A	39-2	M85049/1	62-9	M85049/58	30-2
MS3437A	39-12	M28840/6 B	37-2	M85049/2	62-10	M85049/59	31-3
MS3437B	37-24	M28840/7	65-4	M85049/3 1	37-5	M85049/60-1	31-4
MS3437C	38-10	M28840/8 A	39-3	M85049/3 2	37-6	M85049/60-2G	31-5
MS3480	60-2	M28840/8 B	37-3	M85049/3 3	37-7	M85049/61	30-3
MS3481	60-3	M28840/9 A	39-4	M85049/4 1	37-8	M85049/62	31-6
MS3482	60-4	M28840/9 B	37-4	M85049/4 2	37-10	M85049/63	45-5
MS17349	66-3	M28840/13	66-7	M85049/4 3	37-12	M85049/69	31-7
MS17350	66-3	M28840/15	66-7	M85049/5 1	37-14	M85049/74	68-13
MS20047	66-5*	M28840/22	71-35	M85049/5 2	37-16	M85049/75	68-14
MS20048	66-5*	M28840/23	61-2	M85049/5 3	37-18	M85049/76	39-18
M24758/1	71-2	M28840/24	68-5	M85049/6	39-8	M85049/77	39-19
M24758/2	71-3	M28840/25	71-36	M85049/7	37-20	M85049/78	39-20
M24758/3	71-4	M28840/27	71-38	M85049/8	39-10	M85049/79	39-21
M24758/4	71-5	M28840/30	71-40	M85049/9	37-22	M85049/82	44-5
M24758/5	71-6	M29504/04	68-6	M85049/10	39-12	M85049/83	44-5
M24758/6	71-7	M29504/05	68-7	M85049/11	37-24	M85049/84	44-5
M24758/7	71-8	M38999/1	61-6*	M85049/14S	61-5	M85049/85	44-6
M24758/8	71-11	M38999/2	31-6*	M85049/15	45-3	M85049/86	44-6
M24758/9	71-12	M38999/3	44-4*	M85049/16	45-3	M85049/87	44-6
M24758/10	71-14	M38999/4	40-3*	M85049/17	39-16	M85049/88	44-8
M24758/11	71-16	M38999/5	39-16*	M85049/18	39-17	M85049/89	44-8
M24758/12	71-18	M38999/6	36-5*	M85049/19	38-5	M85049/90	44-8
M24758/13	71-20	M38999/7	38-14*	M85049/20	44-2	M85049/91	62-24
M24758/14	71-22	M38999/8	38-15*	M85049/21	36-4	M85049/92	62-24
M24758/15	71-24	M38999/9	65-5	M85049/23	38-6	M85049/93	68-15
M24758/16	71-26	M38999/10	65-6	M85049/24	38-8	M85049/94	68-16
M24758/17	71-28	D38999/22	65-7	M85049/25	38-10	M85049/95	68-17
M24758/18	71-29	D38999/28	68-8	M85049/26	44-3	M85049/96	68-18
M24758/19	71-30	D38999/32	66-8	M85049/27	61-6	M85528/1	68-19
MS25042	66-4	D38999/33	66-8	M85049/28	50-2	M85528/2	68-20
MS25043	66-4	D38999/50	65-8	M85049/29	36-5	M85528/3	68-18
MS27291	62-2	M81511/13	62-8	M85049/30	40-3	MS90563	66-12
MS27292	66-10	M81511/14 AB	39-6	M85049/31	61-7	MS90564	66-12

* Page Number of Superceding Part Number

© 2005 Glenair, Inc.

CAGE Code 06324

Printed in U.S.A.



Standard Materials and Notes

The following standard materials are used for the majority of Glenair backshells and connector accessories. However, backshell components are not limited to those items

listed, but are representative of the elements used in Glenair's general accessory products. Contact Glenair for applicable specifications on items not listed below.

STANDARD MATERIALS - BACKSHELLS AND ACCESSORIES		
COMPONENT	MATERIAL	SPECIFICATION
Machined components: such as backshell bodies, fabricated elbows, protective covers, rotatable couplers, dummy stowage receptacles, lock nuts, G-spring support rings, EMI ground rings, grommet followers, etc.	Aluminum	AMS-QQ-A-200, 225, ASTM B211, 221, 209
Die cast components: such as angular backshells, strain relief backshells, strain relief bodies, strain relief saddles, special EMI ground rings, etc.	Aluminum	QQ-A-591 ASTM B, 85, 26
Backshells or strain reliefs: available in optional corrosion resisting steel; and hardware: such as screws, washers, rivets, wire rope, sash chain, band straps, etc.	Corrosion Resisting Steel	ASTMA582 (300 Series) AMS-QQ-S-763
Elastomeric seals: such as O-rings, cable jacket seals, grommets, etc.	Silicone	ZZ-R-765, MIL-R-25988
Anti-friction and thrust washers	Teflon	TFE
Anti-rotation devices	Corrosion Resistant Material	N/A

Note: Every effort has been made to present accurate information in this catalog. Editorial errors which are brought to our attention will be corrected in future editions. All dimensions presented in this catalog should be confirmed by the factory prior to inclusion within designs or specifications. We are constantly incorporating product improvements, and therefore Glenair reserves the right to make changes without notice.

Any liability or warranty as to quality, performance or fitness for use of Glenair products is always based on the condition that they apply to only new unused products that are properly stored, handled, installed, used, maintained and inspected by the user in a manner appropriate for the intended use of the product.

Tolerances

On all length callouts, tolerance is $\pm .060$ unless otherwise specified.

Unless otherwise specified, the following other dimensional tolerances will apply:

- .xx = $\pm .03$ (0.8)
- .xxx = $\pm .015$ (0.4)
- Lengths = $\pm .060$ (1.52)
- Angles = $\pm 5^\circ$

INSTALLATION TORQUE VALUES FOR CIRCULAR ELECTRICAL CONNECTOR ACCESSORIES

Accessory Thread Torque: ±5 inch pounds

Shell Sizes	Group 1	Group 2
	Light & Medium Duty MIL-C-5015 (MS3100 Series) MIL-C-26482 Series I MIL-C-26500 MIL-C-27599 MIL-C-38999 Series I, II MIL-C-81511 Series I, II, III, IV MIL-C-81703 Series I	Heavy Duty MIL-C-5015 (MS3400 Series) MIL-C-22992 MIL-C-26482 Series II MIL-C-28840 MIL-C-38999 Series III, IV MIL-C-81703 Series III MIL-C-83723 Series I, II, III
8, 9, A	35	56
3, 10, 10SL, 11, B	35	76
7, 12, 12S, 13, C	40	108
14, 14S, 15, D	40	116
16, 16S, 17, E	40	116
18, 19, 27, F	40	116
20, 21, 37, G	80	136
22, 23, H	80	136
24, 25, 61, J	80	136
28, 29	120	148
32, 33	120	148
36	120	148
40	170	164
44	170	164
48	170	164

- Notes: 1. Group 1 values based on 80% of MIL-C-85049 light duty thread strength.
2. Use Group 1 values for all composite connector accessories when tightened with Glenair 600-091 and 600-007 Torque Tools. Consult factory.

TORQUE VALUES FOR CABLE CLAMP SCREWS

Torque Requirements in Inch-Pounds
for Corrosion-Resistant Steel Screws Only

Screw Size	Recommended Max Torque*
2-56	2.0
4-40	4.0
6-32	6.0
8-32	8.0
10-32	10.0
.250-20	15.0

*Recommended 75-80% of max values for installation into aluminum or composite materials.



Military Standard Connector Index

The following is a listing of circular connectors defined by US Military Specifications, cross-referenced to the applicable active or inactive part number series. The symbols

in the Connector Designator column are an essential element in Glenair's commercial backshell part number developments.

PART NO.	CONN. DESIG.	SPECIFICATION	SERIES	DESCRIPTION
MS3100	B	MIL-C-5015	MS3100	Receptacle, Wall Mtg (Solder)
MS3101	B	MIL-C-5015	MS3100	Receptacle
MS3102	**	MIL-C-5015	MS3100	Receptacle, Box Mtg (Solder)
MS3103	**	MIL-C-5015	MS3100	Receptacle, Potting (Solder)
MS3105	**	MIL-C-5015	MS3100	Dummy Receptacle
MS3106	B	MIL-C-5015	MS3100	Plug, Straight (Solder)
MS3107	B	MIL-C-5015	MS3100	Plug, Quick Disconnect (Solder)
MS3108	B	MIL-C-5015	MS3100	Plug, 90° (Solder)
MS3110	D-729	MIL-C-26482	1	Receptacle, Wall Mtg
MS3111	D	MIL-C-26482	1	Plug, Cable Connecting
MS3112	**	MIL-C-26482	1	Receptacle, Box Mtg
MS3113	**	MIL-C-26482	1	Receptacle, Solder Mtg
MS3114	D-717	MIL-C-26482	1	Receptacle, Jam Nut
MS3115	**	MIL-C-26482	1-2	Dummy Receptacle
MS3116	D	MIL-C-26482	1	Plug, Straight
MS3119	**	MIL-C-26482	1	Receptacle, Thru-Bulkhead
MS3120	D	MIL-C-26482	1	Receptacle, Wall Mtg, (Crimp)
MS3121	D	MIL-C-26482	1	Plug, Straight (Crimp)
MS3122	**	MIL-C-26482	1	Receptacle, Box Mtg, (Crimp)
MS3124	D-717	MIL-C-26482	1	Receptacle, Rear Mtg, Jam Nut (Crimp)
MS3126	D	MIL-C-26482	1	Plug, Straight (Crimp)
MS3127	**	MIL-C-26482	1	Receptacle, Box Mtg (Crimp)
MS3128	*	MIL-C-26482	1	Receptacle, Wall Mtg (Crimp)
MS3130	*	MIL-C-81703	1	Receptacle, Push Pull, Wide Flange
MS3132	X-706	MIL-C-81703	1	Receptacle, Push Pull, Box Mtg
MS3134	X-706	MIL-C-81703	1	Receptacle, Push Pull, Jam Nut
MS3135	**	MIL-C-81703	1	Dummy Receptacle
MS3137	X-706	MIL-C-81703	1	Plug, Straight, Push Pull
MS3138	X-706	MIL-C-81703	1	Plug, Lanyard, Push Pull
MS3139	**	MIL-C-81703	1	Receptacle, Thru-Bulkhead
MS3140	X-706B	MIL-C-81703	2	Receptacle, Push Pull, Wall Mtg
MS3142	**	MIL-C-5015	MS3100	Receptacle, Hermetic, Box Mtg
MS3143	**	MIL-C-5015	MS3100	Receptacle, Hermetic, Solder Mtg
MS3144	X-706B	MIL-C-81703	2	Receptacle, Push Pull, Jam Nut
MS3145	**	MIL-C-81703	3	Receptacle, Hermetic, Push Pull, Box Mtg
MS3146	**	MIL-C-81703	3	Receptacle, Push Pull, Hermetic, Solder Mtg
MS3147	X-706B	MIL-C-81703	2	Plug, Push Pull (Crimp)
MS3148	X-706B	MIL-C-81703	2	Plug, Push Pull, Lanyard (Crimp)
MS3149	**	MIL-C-81703	3	Receptacle, Push Pull, Hermetic

* Consult factory
** Connector does not accommodate rear accessories

Military Standard Connector Index



General Information

PART NO.	CONN. DESIG.	SPECIFICATION	SERIES	DESCRIPTION
MS3400	A	MIL-C-5015	MS3400	Receptacle, Wall Mtg
MS3401	A	MIL-C-5015	MS3400	Receptacle, Cable Connecting
MS3402	**	MIL-C-5015	MS3400	Receptacle,, Box Mtg
MS3404	A	MIL-C-5015	MS3400	Receptacle, Jam Nut
MS3406	A	MIL-C-5015	MS3400	Plug
MS3408	A	MIL-C-5015	MS3400	Plug, 90°
MS3409	A	MIL-C-5015	MS3400	Plug, 45°
MS3412	A	MIL-C-5015	MS3400	Receptacle, Wall Mtg
MS3424	A	MIL-C-81703	3	Receptacle, Push Pull, Wall Mtg
MS3440	**	MIL-C-26482	2	Receptacle, Narrow Flange Mtg (was M83723/9/10)
MS3442	**	MIL-C-26482	2	Receptacle, Wide Flange Mtg
MS3443	**	MIL-C-26482	2	Receptacle, Solder Flange Mtg
MS3445	*	MIL-C-81703	2	Plug, Push Pull, Rack & Panel Mtg
MS3446	A	MIL-C-81703	3	Plug, Rack & Panel
MS3449	**	MIL-C-26482	2	Receptacle, Single Hole Mtg
MS3450	A	MIL-C-5015	MS3450	Receptacle, Wall Mtg (was M83723/19/20)
MS3451	A	MIL-C-5015	MS3450	Receptacle, Cable Connecting (was M83723/17/18)
MS3452	**	MIL-C-5015	MS3450	Receptacle, Box Mtg (was M83723/21/22)
MS3454	A	MIL-C-5015	MS3450	Receptacle, Jam Nut
MS3456	A	MIL-C-5015	MS3450	Plug, Straight (was M83723/23/24)
MS3459	A	MIL-C-5015	MS3450	Plug, Straight, Self Locking (was M83723/52/53)
MS3463	**	MIL-C-81703	3	Receptacle, Push Pull
MS3464	A	MIL-C-81703	3	Receptacle, Push Pull, Jam Nut
MS3466	**	MIL-C-81703	3	Receptacle, Push Pull, Hermetic
MS3467	A	MIL-C-81703	3	Plug, Push Pull
MS3468	A	MIL-C-81703	3	Plug, Push Pull, Lanyard
MS3469	**	MIL-C-81703	3	Receptacle, Push Pull, Hermetic, Jam Nut
MS3470	A	MIL-C-26482	2	Receptacle, Narrow Flange Mtg (was M83723/1/2)
MS3471	A	MIL-C-26482	2	Receptacle, Cable Connecting (was M83723/7/8)
MS3472	A	MIL-C-26482	2	Receptacle, Wide Flange Mtg (was M83723/3/4)
MS3473	**	MIL-C-26482	2	Receptacle, Solder Mtg, Hermetic
MS3474	A	MIL-C-26482	2	Receptacle, Rear Mtg, Jam Nut (was M83723/5/6)
MS3475	A	MIL-C-26482	2	Plug, RFI Shielded (was M83723/42/43)
MS3476	A	MIL-C-26482	2	Plug, Straight (was M83723/13/14)
MS3477	**	MIL-C-26482	2	Receptacle Hermetic, Box Mtg
MS3479	**	MIL-C-26482	2	Receptacle, Hermetic, Rear Mtg, Jam Nut
MS17343	C	MIL-C-22992	R	Receptacle, Wall Mtg
MS17344	C	MIL-C-22992	R	Plug, Straight
MS17345	C	MIL-C-22992	R	Plug, Cable Connecting
MS17346	C	MIL-C-22992	R	Receptacle, Box Mtg
MS17347	C	MIL-C-22992	R	Receptacle, Jam Nut
MS17348	C	MIL-C-22992	R	Receptacle, Jam Nut, Box Mtg
MS18062	**	MIL-C-22992	R	Dummy Receptacle
MS20026	*	MIL-C-27599		Receptacle, Wall Mtg, Solder
MS20027	*	MIL-C-27599		Receptacle, Line
MS20028	*	MIL-C-27599		Plug, Straight
MS20029	**	MIL-C-27599		Receptacle, Jam Nut Mtg

* Consult factory; ** Connector does not accommodate rear accessories

Military Standard Connector Index

PART NO.	CONN. DESIG.	SPECIFICATION	SERIES	DESCRIPTION
MS20030	*	MIL-C-27599		Receptacle, Box Mtg, Hermetic
MS20031	**	MIL-C-27599		Receptacle, Jam Nut, Hermetic
MS20032	**	MIL-C-27599		Receptacle, Solder Mtg, Hermetic
MS20034	*	MIL-C-27599		Receptacle, Wall Mtg
MS20035	*	MIL-C-27599		Receptacle, Box Mtg
MS24264	E	MIL-C-26500	F, G & R	Receptacle, Flange Mtg
MS24265	E	MIL-C-26500	F, G & R	Receptacle, Single Hole Mtg
MS24266	E	MIL-C-26500	F, G & R	Plug, Straight
MS25183	**	MIL-C-5015	MS3100	Plug, Potting Seal
MS27034	**	MIL-C-26500		Receptacle, Hermetic, Solder Mtg
MS27334	*	MIL-C-27599		Receptacle, Wall Mtg
MS27335	**	MIL-C-27599		Receptacle, Box Mtg
MS27336	*	MIL-C-27599		Plug, Straight
MS27337	*	MIL-C-27599		Receptacle, Jam Nut
MS27338	*	MIL-C-27599		Receptacle, Wall Mtg, Hermetic
MS27339	**	MIL-C-27599		Receptacle, Box Mtg, Hermetic
MS27340	**	MIL-C-27599		Receptacle, Jam Nut Mtg, Hermetic
MS27341	**	MIL-C-27599		Receptacle, Solder Mtg, Hermetic
MS27466	F	MIL-C-38999	I	Receptacle, Wall Mtg
MS27467	F	MIL-C-38999	I	Plug, Straight
MS27468	F	MIL-C-38999	I	Receptacle, Jam Nut
MS27469	**	MIL-C-38999	I	Receptacle, Wall Mtg, Hermetic
MS27470	**	MIL-C-38999	I	Receptacle, Jam Nut, Hermetic
MS27471	**	MIL-C-38999	I	Receptacle, Solder Mtg, Hermetic
MS27472	F	MIL-C-38999	II	Receptacle, Wall Mtg
MS27473	F	MIL-C-38999	II	Plug, Straight
MS27474	F	MIL-C-38999	II	Receptacle, Jam Nut
MS27475	F	MIL-C-38999	II	Receptacle, Wall Mtg
MS27476	**	MIL-C-38999	II	Receptacle, Box Mtg, Hermetic
MS27477	**	MIL-C-38999	II	Receptacle, Jam Nut, Hermetic
MS27478	**	MIL-C-38999	II	Receptacle, Solder Mtg, Hermetic
MS27479	F	MIL-C-38999	II	Inactive Use MS27472
MS27480	F	MIL-C-38999	II	Inactive Use MS27473
MS27481	F	MIL-C-38999	II	Inactive Use MS27474
MS27482	F	MIL-C-38999	II	Inactive Use MS27475
MS27483	**	MIL-C-38999	II	Inactive Use MS27477
MS27484P	**	MIL-C-38999	II	Plug, Straight
MS27484T	F	MIL-C-38999	II	Plug, Straight
MS27496	**	MIL-C-38999	I	Receptacle, Box Mtg
MS27497	F	MIL-C-38999	II	Receptacle, Back Panel Wall Mtg
MS27498	F	MIL-C-38999	I	Plug, 90°
MS27499	**	MIL-C-38999	II	Receptacle, Box Mtg
MS27500	F	MIL-C-38999	II	Inactive See MS27473
MS27503	**	MIL-C-38999	II	Inactive See MS27478
MS27504	**	MIL-C-38999	II	Inactive See MS27499
MS27505	**	MIL-C-38999	I	Receptacle, Back Panel Box Mtg
MS27508	**	MIL-C-38999	II	Receptacle, Back Panel Box Mtg

* Consult factory; ** Connector does not accommodate rear accessories

Military Standard Connector Index



General Information

PART NO.	CONN. DESIG.	SPECIFICATION	SERIES	DESCRIPTION
MS27513	**	MIL-C-38999	II	Receptacle, Box Mtg
MS27515	F	MIL-C-38999	I	Inactive Use MS27656
MS27613	E-710	MIL-C-26500K		Receptacle, Panel Mtg
MS27614	E-710	MIL-C-26500K		Receptacle, D-Hole Mtg
MS27615	E-710	MIL-C-26500K		Plug, Straight
MS27652	F	MIL-C-38999	I	Inactive Use MS27466
MS27653	F	MIL-C-38999	I	Inactive Use MS27467
MS27654	F	MIL-C-38999	I	Inactive Use MS27656
MS27656	F	MIL-C-38999	I	Receptacle, Back Panel, Wall Mtg
MS27661	F-752	MIL-C-38999	I	Plug, Lanyard Release
MS27662	**	MIL-C-38999	I	Receptacle, Thru-Bulkhead
MS27664	**	MIL-C-38999	II	Receptacle, Back-Panel Wall Mtg
MS27665	F	MIL-C-38999	I	Plug, Rack & Panel Mtg
MS27667	**	MIL-C-38999	II	Receptacle, Thru-Bulkhead
MS90555	*	MIL-C-22992	L	Receptacle, Wall Mtg
MS90556	*	MIL-C-22992	L	Plug, Straight
MS90557	*	MIL-C-22992	L	Plug, Cable Connecting
MS90558	*	MIL-C-22992	L	Receptacle, W/Coupling Ring, Wall Mtg
M28840/10	G	MIL-C-28840		Receptacle, Wall Mtg
M28840/11	G	MIL-C-28840		Receptacle, Cable Connecting
M28840/12	**	MIL-C-28840		Receptacle, Box Mtg
M28840/14	G	MIL-C-28840		Receptacle, Jam Nut
M28840/16	G	MIL-C-28840		Plug, Straight
D38999/20	H	MIL-C-38999	III	Receptacle, Wall Mtg
D38999/21	**	MIL-C-38999	III	Receptacle, Hermetic
D38999/23	**	MIL-C-38999	III	Receptacle, Hermetic, Jam Nut
D38999/24	H	MIL-C-38999	III	Receptacle, Jam Nut
D38999/25	**	MIL-C-38999	III	Receptacle, Hermetic, Solder Mtg
D38999/26	H	MIL-C-38999	III	Plug, Straight
D38999/27	**	MIL-C-38999	III	Receptacle, Hermetic, Weld Mtg
D38999/29	*	MIL-C-38999	III	Plug, Lanyard Release
D38999/30	H-701	MIL-C-38999	III	Plug, Lanyard Release
D38999/40	H	MIL-C-38999	IV	Receptacle, Wall Mtg
D38999/42	H	MIL-C-38999	IV	Receptacle, Box Mtg
D38999/44	H-715	MIL-C-38999	IV	Receptacle, Jam Nut
D38999/46	H	MIL-C-38999	IV	Plug, Straight, EMI
D38999/47	H	MIL-C-38999	IV	Plug, Straight
M81511/1	J	MIL-C-81511	2	Receptacle, Flange Mtg
M81511/2	**	MIL-C-81511	2	Receptacle, Solder Flange
M81511/3	J	MIL-C-81511	2	Receptacle, Jam Nut
M81511/4	**	MIL-C-81511	2	Receptacle, Jam Nut
M81511/5	J	MIL-C-81511	2	Plug, Cable Connecting
M81511/6	J	MIL-C-81511	2	Plug
M81511/21	J	MIL-C-81511	1	Receptacle, Flange Mtg
M81511/22	**	MIL-C-81511	1	Receptacle, Solder Flange Mtg
M81511/23	J	MIL-C-81511	1	Receptacle, Jam Nut
M81511/24	**	MIL-C-81511	1	Receptacle, Jam Nut

* Consult factory; ** Connector does not accommodate rear accessories

Military Standard Connector Index

PART NO.	CONN. DESIG.	SPECIFICATION	SERIES	DESCRIPTION
M81511/25	J	MIL-C-81511	1	Receptacle, Cable Connecting
M81511/26	J	MIL-C-81511	1	Plug
M81511/27	**	MIL-C-81511	1	Receptacle Thru-Bulkhead, Jam Nut
M81511/28	**	MIL-C-81511	2	Receptacle, Thru-Bulkhead, Single Hole Mtg
M81511/31	J	MIL-C-81511	2	Receptacle, Flange Mtg
M81511/32	J	MIL-C-81511	2	Receptacle, Jam Nut Mtg
M81511/33	J	MIL-C-81511	2	Receptacle, Cable Connecting
M81511/34	J	MIL-C-81511	2	Plug
M81511/35	J	MIL-C-81511	1	Receptacle, Flange Mtg
M81511/36	J	MIL-C-81511	1	Receptacle, Jam Nut
M81511/37	J	MIL-C-81511	1	Receptacle, Cable Connecting
M81511/38	J	MIL-C-81511	1	Plug
M81511/41	J	MIL-C-81511	3	Receptacle, Flange Mtg
M81511/42	**	MIL-C-81511	3	Receptacle, Solder Flange Mtg
M81511/44	**	MIL-C-81511	3	Receptacle, Jam Nut
M81511/45	J	MIL-C-81511	3	Receptacle, Cable Connecting
M81511/46	J	MIL-C-81511	3	Plug
M81511/47	**	MIL-C-81511	3	Receptacle, Solder Flange Mtg
M81511/48	**	MIL-C-81511	3	Receptacle, Jam Nut
M81511/49	J	MIL-C-81511	3	Receptacle, Jam Nut
M81511/50	**	MIL-C-81511	4	Receptacle, Jam Nut
M81511/51	J	MIL-C-81511	4	Receptacle, Flange Mtg
M81511/52	**	MIL-C-81511	4	Receptacle, Solder Flange Mtg
M81511/53	J	MIL-C-81511	4	Receptacle, Jam Nut
M81511/54	**	MIL-C-81511	4	Receptacle, Jam Nut
M81511/55	J	MIL-C-81511	4	Receptacle, Cable Connecting
M81511/56	J	MIL-C-81511	4	Plug
M81511/57	**	MIL-C-81511	4	Receptacle, Solder Flange Mtg
M81582/1	*	MIL-C-81582		Receptacle, Single Hole Mtg
M81582/2	*	MIL-C-81582		Plug, Lanyard Release
M83723/1	A	MIL-C-83723	I	Superseded by MS3470
M83723/2	A	MIL-C-83723	I	Superseded by MS3470
M83723/3	A	MIL-C-83723	I	Superseded by MS3472
M83723/4	A	MIL-C-83723	I	Superseded by MS3472
M83723/5	A	MIL-C-83723	I	Superseded by MS3474
M83723/6	A	MIL-C-83723	I	Superseded by MS3474
M83723/7	A	MIL-C-83723	I	Superseded by MS3471
M83723/8	A	MIL-C-83723	I	Superseded by MS3471
M83723/9	**	MIL-C-83723	I	Superseded by MS3440
M83723/10	**	MIL-C-83723	I	Superseded by MS3442
M83723/11	**	MIL-C-83723	I	Superseded by MS3443
M83723/12	**	MIL-C-83723	I	Superseded by MS3443
M83723/13	A	MIL-C-83723	I	Superseded by MS3476
M83723/14	A	MIL-C-83723	I	Superseded by MS3476
M83723/17	K	MIL-C-83723	II	Superseded by MS3451
M83723/18	K	MIL-C-83723	II	Superseded by MS3451
M83723/19	K	MIL-C-83723	II	Superseded by MS3450

* Consult factory; ** Connector does not accommodate rear accessories

Military Standard Connector Index



General Information

PART NO.	CONN. DESIG.	SPECIFICATION	SERIES	DESCRIPTION
M83723/20	K	MIL-C-83723	II	Superseded by MS3450
M83723/21	**	MIL-C-83723	II	Superseded by MS3452
M83723/22	**	MIL-C-83723	II	Superseded by MS3452
M83723/23	K	MIL-C-83723	II	Superseded by MS3456
M83723/24	K	MIL-C-83723	II	Superseded by MS3456
M83723/25	**	MIL-C-83723	II	Superseded by MS3142
M83723/26	**	MIL-C-83723	II	Superseded by MS3143
M83723/36	A	MIL-C-83723	I	Inactive For New Design
M83723/37	A	MIL-C-83723	I	Inactive For New Design
M83723/38	A	MIL-C-83723	I	Inactive For New Design
M83723/39	A	MIL-C-83723	I	Inactive For New Design
M83723/40	A	MIL-C-83723	I	Inactive For New Design
M83723/41	A	MIL-C-83723	I	Inactive For New Design
M83723/42	A	MIL-C-83723	I	Superseded by MS3475
M83723/43	A	MIL-C-83723	I	Superseded by MS3475
M83723/45	**	MIL-C-83723	I	Superseded by MS3115
M83723/48	A	MIL-C-83723	I	Inactive For New Design
M83723/49	A	MIL-C-83723	I	Inactive For New Design
M83723/52	K	MIL-C-83723	II	Superseded by MS3459
M83723/53	K	MIL-C-83723	II	Superseded by MS3459
M83723/66	A	MIL-C-83723	III	Plug, Push Pull (Pin Contacts)
M83723/67	A	MIL-C-83723	III	Plug, Push Pull (Socket Contacts)
M83723/68	A	MIL-C-83723	III	Plug, Push Pull Lanyard, (Pin Contacts)
M83723/69	A	MIL-C-83723	III	Plug, Push Pull, Lanyard, (Socket Contacts)
M83723/71	A	MIL-C-83723	III	Receptacle, Bayonet, Flange Mtg, (Socket Contact)
M83723/72	A	MIL-C-83723	III	Receptacle, Bayonet, Flange Mtg, (Pin Contact)
M83723/73	A	MIL-C-83723	III	Receptacle, Bayonet, Single Hole Mtg, (Socket Contact)
M83723/74	A	MIL-C-83723	III	Receptacle, Bayonet Single Mtg, (Pin Contact)
M83723/75	A	MIL-C-83723	III	Plug, Bayonet (Socket Contact)
M83723/76	A	MIL-C-83723	III	Plug, Bayonet (Pin Contact)
M83723/77	A	MIL-C-83723	III	Plug, Bayonet, RFI (Socket Contact)
M83723/78	A	MIL-C-83723	III	Plug, Bayonet, RFI (Pin Contact)
M83723/79	**	MIL-C-83723	III	Receptacle, Bayonet Flange Mtg, Hermetic
M83723/80	**	MIL-C-83723	III	Receptacle, Bayonet Solder Flange Mtg, Hermetic
M83723/81	**	MIL-C-83723	III	Receptacle, Bayonet Single Hole Mtg, Hermetic
M83723/82	A	MIL-C-83723	III	Receptacle, Threaded, Flange Mtg, (Socket Contact)
M83723/83	A	MIL-C-83723	III	Receptacle, Threaded, Flange Mtg, (Pin Contact)
M83723/84	A	MIL-C-83723	III	Receptacle, Threaded Single Hole Mtg, (Socket Contact)
M83723/85	A	MIL-C-83723	III	Receptacle, Threaded Single Hole Mtg, (Pin Contact)
M83723/86	A	MIL-C-83723	III	Plug, Threaded, (Socket Contact)
M83723/87	A	MIL-C-83723	III	Plug, Threaded, (Pin Contact)
M83723/88	**	MIL-C-83723	III	Receptacle, Threaded, Flange Mtg, (Pin Contact)
M83723/89	**	MIL-C-83723	III	Receptacle, Threaded, Single Hole Mtg, Hermetic
M83723/90	**	MIL-C-83723	III	Receptacle, Threaded, Solder Flange Mtg, Hermetic
M83723/91	A	MIL-C-83723	III	Plug, Threaded, RFI (Socket Contact)
M83723/92	A	MIL-C-83723	III	Plug, Threaded, RFI (Pin Contact)
M83723/93	**	MIL-C-83723	III	Receptacle, Bayonet, Solder Flange Mtg, Hermetic

* Consult factory; ** Connector does not accommodate rear accessories

Military Standard Connector Index

PART NO.	CONN. DESIG.	SPECIFICATION	SERIES	DESCRIPTION
M83723/94	**	MIL-C-83723	III	Receptacle, Bayonet, Single Hole Mtg, Hermetic
M83723/95	A	MIL-C-83723	III	Plug, Threaded, (Socket Contact), Self Locking
M83723/96	A	MIL-C-83723	III	Plug, Threaded, (Pin Contact), Self Locking
M83723/97	A	MIL-C-83723	III	Plug, Threaded, RFI (Socket Contact), Self Locking
M83723/98	A	MIL-C-83723	III	Plug, Threaded, RFI (Pin Contact), Self Locking
NATC00	H*	SSQ21635		Receptacle, Flange
NATC06	H*	SSQ21635		Plug
NATC07	H*	SSQ21635		Receptacle, Jam Nut
NATC09	***	SSQ21635		Receptacle, Weld Mtg
NATC77	***	SSQ21635		Receptacle, Jam Nut
NATC99	***	SSQ21635		Receptacle, Weld Mtg
NBO	A	40M39569		Receptacle, Flange Mtg
NBOH	**	40M39569		Receptacle, Hermetic
NB3H	**	40M39569		Receptacle, Hermetic
NB4	A	40M39569		Receptacle, Flange Mtg
NB5H	**	40M39569		Thru-Bulkhead, Hermetic
NB6	A	40M39569		Plug, Straight
NB6G	A	40M39569		Plug, Straight, EMI
NB7	A	40M39569		Receptacle, Jam Nut
NB7H	**	40M39569		Receptacle, Hermetic
NB8H	**	40M39569		Receptacle, Hermetic
NLSO	F	40M38277		Receptacle, Flange Mtg
NLS3H	**	40M38277		Receptacle, Hermetic
NLS6	F	40M38277		Plug, Straight
NLS6G	F	40M38277		Plug, Straight, EMI
NLS7	F	40M38277		Receptacle, Jam Nut
NLS7H	**	40M38277		Receptacle, Jam Nut
NZGL00	H**	SSQ21635		Receptacle, Flange
NZGL03	***	SSQ21635		Receptacle, Lever
NZGL06	H**	SSQ21635		Plug
NZGL07	H**	SSQ21635		Receptacle, Weld Mtg
NZGL09	***	SSQ21635		Receptacle, Weld Mtg
NZGL66	H**	SSQ21635		Plug
NZGL77	***	SSQ21635		Receptacle, Jam Nut
NZGL99	***	SSQ21635		Receptacle, Weld Mtg
* Consult factory				
** Connector does not accommodate rear accessories				
H* NATC Series size 09 through 25 mates to Glenair Connector Designator H, consult factory for sizes 33 & 37				
H** NZGL Series requires special accessories manufactured by Glenair, consult factory				
*** Connector noted does not have accessory thread. (NZGL and NATC hermetic/control leakage classes.)				



Potting Boot Rings are designed for use with M85049/74 and /75 potting boots. The plastic potting boots snap in place to provide an easy and convenient receptacle for cable sealing potting material.

Military Specification	Superceeding Part Number	Glenair's Commercial Catalog P/N	Description	Connector Interface or Glenair Designator	Page Number
MS27485	M85049/58	**	Potting Boot Adapter	F	30-2*
AS85049/58		**	Potting Boot Ring	F	30-2
AS85049/61		**	Potting Boot Ring	MIL-C-27599	30-3

* Page Number of Superceeding Part Number
 ** Consult Factory

AS85049/58 Potting Boot Ring

Glenair Connector
Designator F

MIL-C-38999 Series I & II,
40M38277, PAN 6433-1,
PATT 614, PATT 616,
NFC93422 Series HE308 &
HE309

M85049/58-10

Basic Part No. _____ Dash No. _____

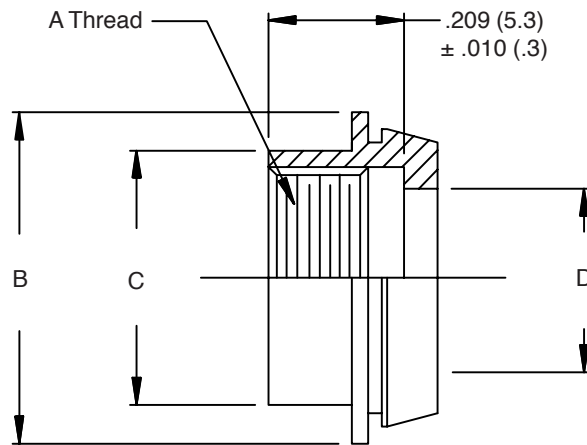

TABLE I

Dash No.	Shell Size Ref.	A Thread UNEF-2B	B Dia Max	C Dia Max	D Dia $\pm .005 (.1)$
8	8/9	.4375 - 28	.600 (15.2)	.506 (12.9)	.344 (8.7)
10	10/11	.5625 - 24	.726 (18.4)	.631 (16.0)	.472 (12.0)
12	12/13	.6875 - 24	.850 (21.6)	.756 (19.2)	.586 (14.9)
14	14/15	.8125 - 20	.976 (24.8)	.881 (22.4)	.711 (18.1)
16	16/17	.9375 - 20	1.012 (25.7)	1.006 (25.6)	.836 (21.2)
18	18/19	1.0625 - 18	1.226 (31.1)	1.131 (28.7)	.942 (23.9)
20	20/21	1.1875 - 18	1.352 (34.3)	1.256 (31.9)	1.067 (27.1)
22	22/23	1.3125 - 18	1.476 (37.5)	1.381 (35.1)	1.192 (30.3)
24	24/25	1.4375 - 18	1.602 (40.7)	1.506 (38.3)	1.317 (33.5)

1. For complete dimensions see applicable Military Specification.
2. Metric dimensions (mm) are indicated in parentheses.
3. Finish: 500 Hour Cadmium Olive Drab Over Electroless Nickel.
4. See page 68-12 for M85049/75 potting boot which can be used with this potting ring.

AS85049/61 Potting Boot Ring



Potting Boot
Rings

For MIL-C-27599
Connectors

M85049/61-10
Basic Part No. _____ Dash No.

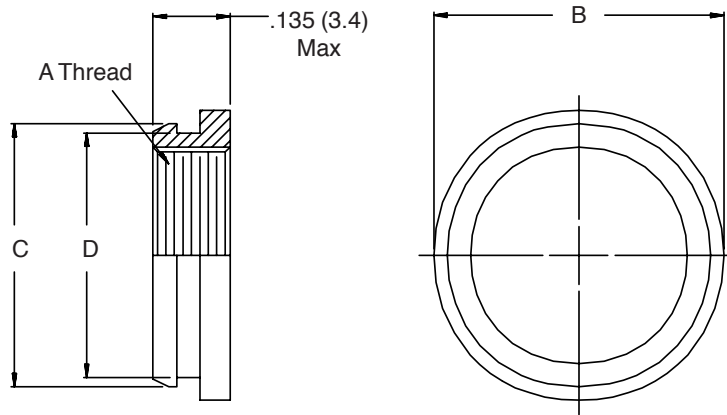

TABLE I

Dash No.	Shell Size Ref.	A Thread UNEF-2B	B Dia Max	C Dia		D Dia	
				±.005 (.1)	±.010 (.3)		
8	8/9	.4375 - 28	.594 (15.1)	.521 (13.2)	.476 (12.1)		
10	10/11	.5625 - 24	.734 (18.6)	.647 (16.4)	.602 (15.3)		
12	12/13	.6875 - 24	.844 (21.4)	.771 (19.6)	.726 (18.4)		
14	14/15	.8125 - 20	.969 (24.6)	.897 (22.8)	.852 (21.6)		
16	16/17	.9375 - 20	1.094 (27.8)	1.023 (26.0)	.978 (24.8)		
18	18/19	1.0625 - 18	1.234 (31.3)	1.147 (29.1)	1.102 (28.0)		
20	20/21	1.1875 - 18	1.344 (34.1)	1.273 (32.3)	1.228 (31.2)		
22	22/23	1.3125 - 18	1.469 (37.3)	1.397 (35.5)	1.352 (34.3)		
24	24/25	1.4375 - 18	1.594 (40.5)	1.524 (38.7)	1.478 (37.5)		

1. For complete dimensions see applicable Military Specification.
2. Metric dimensions (mm) are indicated in parentheses.
3. Finish: 500 Hour Cadmium Olive Drab Over Electroless Nickel.
4. See page 68-11 for M85049/74 potting boot which can be used with this potting ring.

Glenair Series 80 “Mighty Mouse” Connectors



The Mouse That Roared

One of the most common design requirements for interconnect technology used in high-reliability applications is size and weight reduction. When electronic systems expand in number and complexity in military air, sea and ground applications, the available space for interconnect cabling is reduced. And when the latest generation of land vehicle, fighter jet or Navy ship needs to accommodate more systems and controls than ever before—

and still weigh less than it did last time—then reducing connector package size and weight becomes a critical concern.

The Glenair Series 80 “Mighty Mouse” Connector was built precisely for such situations. At less than 1/2 the size and weight of high-density connectors such as the D38999—with comparable environmental and mechanical performance—the Series 80 Connector is truly “The Mouse That Roared.”



1211 Air Way

Glendale, California 91201-2497

Telephone: 818-247-6000 · Facsimilie: 818-500-9912 · EMail: sales@glenair.com

United States · United Kingdom · Germany · Nordic · France · Italy · Spain

www.glenair.com

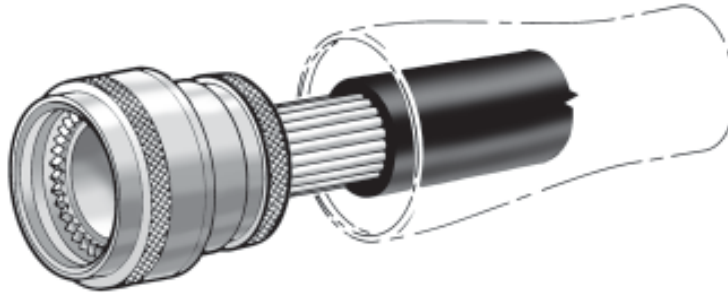

The Shrink Boot Adapters included in this section all are designed to accommodate lipped-type shrink boots such as those defined on MS3109 and MS3117 (not supplied by Glenair). Shrink boots are used both for mechanical strain relief and a degree of environmental protection.

Military Specification	Superceding Part Number	Glenair's Commercial Catalog P/N	Description	Glenair Connector Designator	Page Number
MS3158	M85049/60-1	310AS001	Shrink Boot Adapter	A	31-4
MS3416G	M85049/60-2G	310AS002	Shrink Boot Adapter	A	31-5
M38999/2	M85049/62	310FS001	Shrink Boot Adapter	F	31-6*
M83723/16M	M85049/60-2G	310AS002	Shrink Boot Adapter	A	31-5*
M83723/27M		310KS002	Shrink Boot Adapter	K	31-2
AS85049/59		310CS002	Shrink Boot Adapter	C	31-3
AS85049/60-1		310AS001	Shrink Boot Adapter	A	31-4
AS85049/60-2G		310AS002	Shrink Boot Adapter	A	31-5
AS85049/62		310FS001	Shrink Boot Adapter	F	31-6
AS85049/69		310HS001	Shrink Boot Adapter	H	31-7

* Page Number of Superceding Part Number

M83723/27M Shrink Boot Adapters

Glenair Connector
Designator K

MIL-C-83723 Series II

M83723/27M 22 (M)
 Basic Part No. ———— Backshell Only
 Dash Number ————

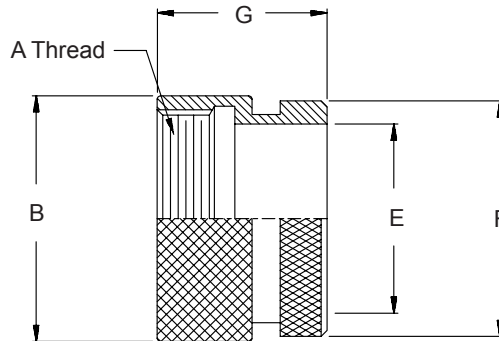

TABLE I

Dash No.	Shell Size Ref.	A Thread Class 2B	B Dia Max	E Dia	F Dia Min	G Max
08	8S	.438 - 28 UNEF	.58 (14.7)	.250 (6.4)	.479 (12.2)	.830 (21.1)
10	10S	.500 - 28 UNEF	.64 (16.3)	.303 (7.7)	.539 (13.7)	.830 (21.1)
11	10SL	.562 - 24 UNEF	.70 (17.8)	.383 (9.7)	.608 (15.4)	.830 (21.1)
12	12	.625 - 24 UNEF	.76 (19.3)	.408 (10.4)	.659 (16.7)	.830 (21.1)
13	12S	.625 - 24 UNEF	.76 (19.3)	.408 (10.4)	.659 (16.7)	.830 (21.1)
14	14	.750 - 20 UNEF	.89 (22.6)	.490 (12.4)	.782 (19.9)	.830 (21.1)
15	14S	.750 - 20 UNEF	.89 (22.6)	.490 (12.4)	.782 (19.9)	.830 (21.1)
16	16	.875 - 20 UNEF	1.01 (25.7)	.609 (15.5)	.908 (23.1)	.996 (25.3)
17	16S	.875 - 20 UNEF	1.01 (25.7)	.609 (15.5)	.908 (23.1)	.996 (25.3)
18	18	1.000 - 20 UNEF	1.14 (29.0)	.730 (18.5)	1.025 (26.0)	.996 (25.3)
20	20	1.125 - 18 UNEF	1.26 (32.0)	.870 (22.1)	1.212 (30.8)	.996 (25.3)
22	22	1.250 - 18 UNEF	1.39 (35.3)	.978 (24.8)	1.343 (34.1)	.996 (25.3)
24	24	1.375 - 18 UNEF	1.52 (38.6)	1.090 (27.7)	1.450 (36.8)	.996 (25.3)
28	28	1.625 - 18 UNEF	1.76 (44.7)	1.250 (31.8)	1.671 (42.4)	1.076 (27.3)
32	32	1.875 - 16 UN	2.01 (51.1)	1.520 (38.6)	1.956 (49.7)	1.076 (27.3)
36	36	2.125 - 16 UN	2.26 (57.4)	1.756 (44.6)	2.164 (55.0)	1.076 (27.3)
40	40	2.375 - 16 UN	2.51 (63.8)	1.880 (47.8)	2.500 (63.5)	1.222 (31.0)

1. For complete dimensions see applicable Military Specification.
2. Finish: Electroless Nickel
3. Metric dimensions (mm) are indicated in parentheses.

AS85049/59 Shrink Boot Adapter



Shrink Boot
Adapters

Glenair Connector
Designator C

MIL-C-22992

M85049/59 A 10

Basic Part No. _____ Adapter Size

Finish _____
 A = Black Anodize
 W = 500 Hour Cadmium Olive Drab
 Over Electroless Nickel

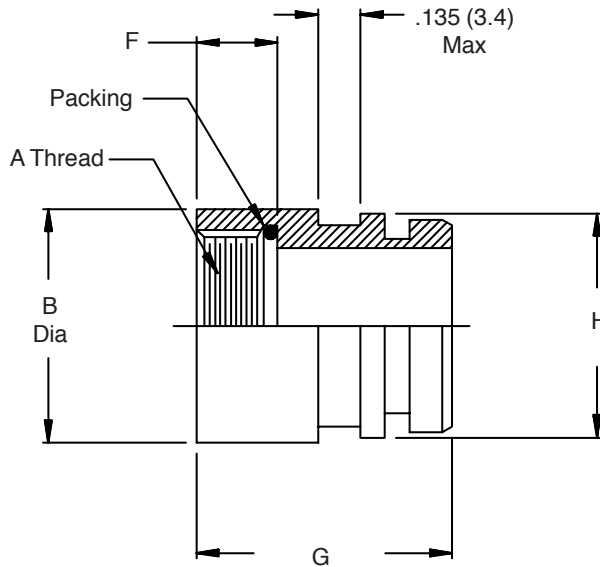

TABLE I

Adapter Size	A Thread Class 2B-LH	B Max	F $\pm 0.016 (.4)$	G $\pm 0.031 (.8)$	H Dia $\pm 0.010 (.3)$
12	.750 - 20 UNEF	.933 (23.7)	.479 (12.2)	1.175 (29.8)	.798 (20.3)
14	.875 - 20 UNEF	1.057 (26.8)	.479 (12.2)	1.175 (29.8)	.922 (23.4)
16	1.000 - 20 UNEF	1.182 (30.0)	.479 (12.2)	1.175 (29.8)	1.048 (26.6)
18	1.125 - 18 UNEF	1.307 (33.2)	.479 (12.2)	1.175 (29.8)	1.172 (29.8)
20	1.250 - 18 UNEF	1.532 (38.9)	.479 (12.2)	1.175 (29.8)	1.297 (32.9)
22	1.375 - 18 UNEF	1.557 (39.5)	.479 (12.2)	1.175 (29.8)	1.423 (36.1)
24	1.625 - 18 UNEF	1.797 (45.6)	.479 (12.2)	1.175 (29.8)	1.662 (42.2)
28	1.875 - 16 UN	2.057 (52.2)	.479 (12.2)	1.175 (29.8)	1.922 (48.8)
32	2.062 - 16 UN	2.307 (58.6)	.479 (12.2)	1.175 (29.8)	2.172 (55.2)
36	2.312 - 16 UN	2.557 (64.9)	.479 (12.2)	1.175 (29.8)	2.422 (61.5)
40	2.625 - 16 UN	2.869 (72.9)	.667 (16.9)	1.375 (34.9)	2.734 (69.4)
44	2.875 - 16 UN	3.120 (79.2)	.667 (16.9)	1.375 (34.9)	2.982 (75.7)

1. For complete dimensions see applicable Military Specification.
2. Metric dimensions (mm) are indicated in parentheses.

AS85049/60-1 and MS3158 Shrink Boot Adapters

**Glenair Connector
Designator A**

MIL-DTL-5015 Series 3400,
MIL-DTL-26482 Series 2,
AS81703 Series 3,
MIL-DTL-83723 Series I &
III, 40M39569, DEF 5326-3,
EN 2997, EN 3646,
ESC 10, ESC 11, LN 29504,
NFC93422 Series HE302,
PAN 6432-1, PAN 6432-2,
PATT 602

M85049/60-1 W 22

Basic Part No. _____ Shell Size _____
Finish _____
A = Anodize Black
N = Electroless Nickel
W = 1,000 Hr. Cadmium Olive Drab

MS3158-22 C

Basic Part No. _____ Finish _____
Shell Size _____
A = 1,000 Hr. Cadmium Olive Drab
C = Cadmium Olive Drab
N = Electroless Nickel

Superceded Part Number

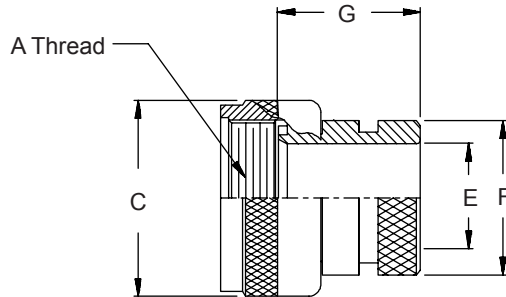

1. For complete dimensions see applicable Military Specification.
2. Metric dimensions (mm) are indicated in parentheses.

TABLE I

Shell Size	A Thread Class 2B	C Dia Max		E Min Dia	F Dia		G Max
		+0.00 (-0.00)	-0.045 (1.14)		+0.00 (0.0)	-0.020 (0.5)	
3	.562 - 24 UNEF	.67 (17.0)	.62 (15.7)	.250 (6.4)	.533 (13.5)	.832 (21.1)	
8	.500 - 20 UNF	.62 (15.7)	.74 (18.8)	.250 (6.4)	.533 (13.5)	.832 (21.1)	
10	.625 - 24 UNEF	.74 (18.8)	.86 (21.8)	.355 (9.0)	.605 (15.4)	.832 (21.1)	
12	.750 - 20 UNEF	.86 (21.8)	.98 (24.9)	.491 (12.5)	.774 (19.7)	.832 (21.1)	
14	.875 - 20 UNEF	.98 (24.9)	1.11 (28.2)	.565 (14.4)	.838 (21.3)	.832 (21.1)	
16	1.000 - 20 UNEF	1.11 (28.2)	1.22 (31.0)	.690 (17.5)	.963 (24.5)	.832 (21.1)	
18	1.062 - 18 UNEF	1.22 (31.0)	1.35 (34.3)	.769 (19.5)	1.042 (26.5)	.832 (21.1)	
20	1.188 - 18 UNEF	1.35 (34.3)	1.59 (40.4)	.894 (22.7)	1.217 (30.9)	.832 (21.1)	
22	1.313 - 18 UNEF	1.47 (37.3)	1.97 (50.0)	1.019 (25.9)	1.355 (34.4)	.832 (21.1)	
24	1.438 - 18 UNEF	1.59 (40.4)	2.22 (56.4)	1.134 (28.8)	1.443 (36.7)	.832 (21.1)	
28	1.750 - 18 UNS	1.97 (50.0)	2.47 (62.7)	1.369 (34.8)	1.709 (43.4)	.994 (25.3)	
32	2.000 - 18 UNS	2.22 (56.4)	2.72 (69.1)	1.615 (41.0)	1.919 (48.7)	.994 (25.3)	
36	2.250 - 16 UN	2.47 (62.7)	2.97 (75.4)	1.830 (46.5)	2.169 (55.1)	.994 (25.3)	
40	2.500 - 16 UN	2.72 (69.1)	3.22 (81.8)	2.045 (51.9)	2.402 (61.0)	.994 (25.3)	
44	2.750 - 16 UN	2.97 (75.4)	3.22 (81.8)	2.300 (58.4)	2.657 (67.5)	.994 (25.3)	
48	3.000 - 16 UN	3.22 (81.8)	1.65 (41.9)	2.550 (64.8)	2.907 (73.8)	.994 (25.3)	
61	1.500 - 18 UNEF	1.65 (41.9)	1.174 (29.8)	1.174 (29.8)	1.529 (38.8)	.832 (21.1)	

AS85049/60-2G and MS3416-G Shrink Boot Adapters



Shrink Boot
Adapters

Glenair Connector Designator A

MIL-DTL-5015 Series 3400,
MIL-DTL-26482 Series 2,
AS81703 Series 3,
MIL-DTL-83723 Series I &
III, 40M39569, DEF 5326-3,
EN 2997, EN 3646,
ESC 10, ESC 11, LN 29504,
NFC93422 Series HE302,
PAN 6432-1, PAN 6432-2,
PATT 602

M85049/60-2G 22 W

Basic Part No. _____
Shell Size _____

Finish
A = Anodize Black
N = Electroless Nickel
W = 1,000 Hr. Cadmium Olive Drab
Over Electroless Nickel

MS3416-22 G C

Basic Part No. _____
Shell Size _____
Style _____

Superseded Part Number

Finish
C = Cadmium Olive Drab Over
Electroless Nickel
N = Electroless Nickel

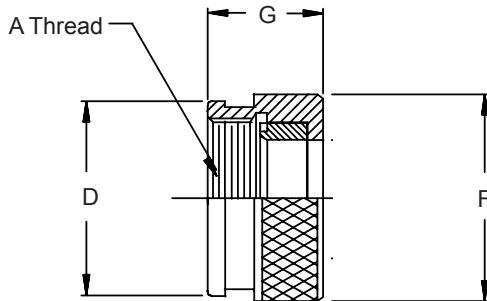

1. For complete dimensions see applicable Military Specification.
2. Metric dimensions (mm) are indicated in parentheses.

TABLE I

Shell Size	A Thread Class 2B	D Dia		F Dia		G Max
		+0.00 -0.020	(0.0) (0.5)	+0.00 -0.045	(0.0) (1.1)	
3	.562 - 24 UNEF	.709	(18.0)	.750	(19.1)	.540 (13.7)
8	.500 - 20 UNF	.657	(16.7)	.688	(17.5)	.540 (13.7)
10	.625 - 24 UNEF	.774	(19.7)	.803	(20.4)	.540 (13.7)
12	.750 - 20 UNEF	.898	(22.8)	.938	(23.8)	.540 (13.7)
14	.875 - 20 UNEF	1.024	(26.0)	1.063	(27.0)	.540 (13.7)
16	1.000 - 20 UNEF	1.152	(29.3)	1.238	(31.4)	.540 (13.7)
18	1.062 - 18 UNEF	1.243	(31.6)	1.310	(33.3)	.540 (13.7)
20	1.188 - 18 UNEF	1.370	(34.8)	1.436	(36.5)	.540 (13.7)
22	1.313 - 18 UNEF	1.443	(36.7)	1.560	(39.6)	.540 (13.7)
24	1.438 - 18 UNEF	1.618	(41.1)	1.686	(42.8)	.540 (13.7)
28	1.750 - 18 UNS	1.969	(50.0)	2.062	(52.4)	.702 (17.8)
32	2.000 - 18 UNS	2.219	(56.4)	2.312	(58.7)	.702 (17.8)
36	2.250 - 16 UN	2.469	(62.7)	2.562	(65.1)	.702 (17.8)
40	2.500 - 16 UN	2.719	(69.1)	2.812	(71.4)	.702 (17.8)
44	2.750 - 16 UN	2.969	(75.4)	3.062	(77.8)	.702 (17.8)
48	3.000 - 16 UN	3.219	(81.8)	3.312	(84.1)	.702 (17.8)
61	1.500 - 18 UNEF	1.653	(42.0)	1.748	(44.4)	.540 (13.7)

AS85049/62 and M38999/2 Shrink Boot Adapters

**Glenair Connector
Designator F**

**MIL-DTL-38999 Series I &
II, 40M38277, PAN 6433-1,
PATT 614, PATT 616,
NFC93422 Series HE308 &
HE309**

M85049/62-10 W D

Basic Part No. _____
Shell Size _____

Drain Hole Option (Omit for none)
Finish

A = Anodize Black
N = Electroless Nickel
W = 1,000 Hr. Cadmium Olive Drab
Over Electroless Nickel

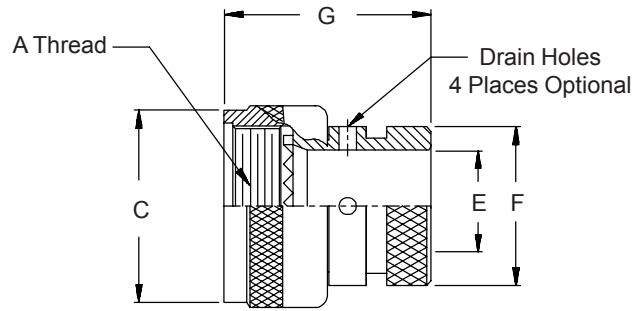

TABLE I

Shell Size	A Thread Class 2B	C Dia		E Dia Min	F Dia Min	G Max
		+ .000 (-0.0)	(0.0) (1.6)			
08	.438 - 28 UNEF	.567	(14.4)	.250 (6.4)	.533 (13.5)	1.000 (25.4)
10	.562 - 24 UNEF	.704	(17.9)	.375 (9.5)	.605 (15.4)	1.000 (25.4)
12	.688 - 24 UNEF	.829	(21.1)	.500 (12.7)	.774 (19.7)	1.000 (25.4)
14	.813 - 20 UNEF	.954	(24.2)	.625 (15.9)	.838 (21.3)	1.000 (25.4)
16	.938 - 20 UNEF	1.079	(27.4)	.750 (19.1)	.963 (24.5)	1.000 (25.4)
18	1.063 - 18 UNEF	1.203	(30.6)	.812 (20.6)	1.042 (26.5)	1.000 (25.4)
20	1.188 - 18 UNEF	1.329	(33.8)	.937 (23.8)	1.217 (30.9)	1.000 (25.4)
22	1.313 - 18 UNEF	1.454	(36.9)	1.062 (27.0)	1.355 (34.4)	1.000 (25.4)
24	1.438 - 18 UNEF	1.579	(40.1)	1.188 (30.2)	1.443 (36.7)	1.000 (25.4)

1. For complete dimensions see applicable Military Specification.
2. Metric dimensions (mm) are indicated in parentheses.

AS85049/69 Shrink Boot Adapters



Shrink Boot
Adapters

Glenair Connector
Designator H

MIL-DTL-38999
Series III & IV,
EN3645

M85049/69-11 A D

Basic Part No. _____

Shell Size _____

Drain Hole Option (Omit for none)

Finish
A = Anodize Black

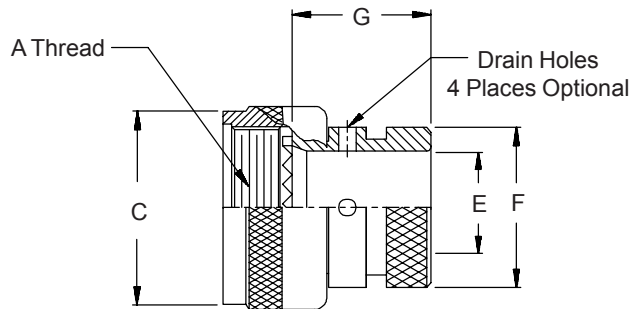

TABLE I

Shell Size	A Thread Class 2B	C Dia Max	E Dia Min	F Dia Max	G Max
9	M12 X 1 - 6H	.600 (15.24)	.250 (6.4)	.533 (13.5)	.710 (18.0)
11	M15 X 1 - 6H	.717 (18.21)	.375 (9.5)	.605 (15.4)	.710 (18.0)
13	M18 X 1 - 6H	.834 (21.18)	.500 (12.7)	.774 (19.7)	.710 (18.0)
15	M22 X 1 - 6H	.990 (25.14)	.625 (15.9)	.838 (21.3)	.710 (18.0)
17	M25 X 1 - 6H	1.107 (28.12)	.750 (19.1)	.963 (24.5)	.710 (18.0)
19	M28 X 1 - 6H	1.224 (31.09)	.812 (20.6)	1.042 (26.5)	.710 (18.0)
21	M31 X 1 - 6H	1.341 (34.06)	.938 (23.8)	1.217 (30.9)	.710 (18.0)
23	M34 X 1 - 6H	1.453 (36.90)	1.062 (27.0)	1.355 (34.4)	.710 (18.0)
25	M37 X 1 - 6H	1.567 (39.80)	1.188 (30.2)	1.443 (36.7)	.710 (18.0)

1. For complete dimensions see applicable Military Specification.
2. Metric dimensions (mm) are indicated in parentheses.

Need something unusual in a multi-contact connector?



Then consider Glenair's expertise in high reliability connector design and development.

Glenair's line of innovative, specialty connectors has grown, year after year, to become one of the most diverse in the industry. Our application engineers have worked directly with commercial, industrial and military customers worldwide to design and build such products as quick disconnects for missile launchers, high tempera-

ture connectors for jet engines, shorting plugs to prevent accidental weapon firing, explosion-proof bulkhead feed-throughs for marine and off-shore platform use, and hermetically-sealed MIL-DTL-38999 connectors for military applications. So, for extraordinary applications, consider an extraordinary partner: Glenair.



Commercial and Mil Spec connector accessories



Convolute tubing and metal-core conduit



Electrical and fiber optic cable assemblies



Composite thermoplastic components



Microminiature connectors and accessories



Backshell assembly and termination tools



1211 Air Way
Glendale, California 91201-2497

Telephone: 818-247-6000 · Facsimilie: 818-500-9912 · EMail: sales@glenair.com

United States • United Kingdom • Germany • Nordic • France • Italy • Spain

www.glenair.com



The accessories in this section are simple straight backshells which provide for thread adaptations or extensions behind the connector.

Military Specification	Superceeding Part Number	Glenair's Commercial Catalog P/N	Description	Glenair Connector Designator or Interface	Page Number
MS3184	M85049/34	**	Adapter	D	32-3*
M83538/9		**	Adapter	MIL-DTL-83538/4	32-2
AS85049/34		**	Adapter	D	32-3

* Page Number of Superceeding Part Number
 ** Consult Factory

For Use With
MIL-C-83538/4

M83538/9S 09

Basic Part No. _____ Shell Size _____

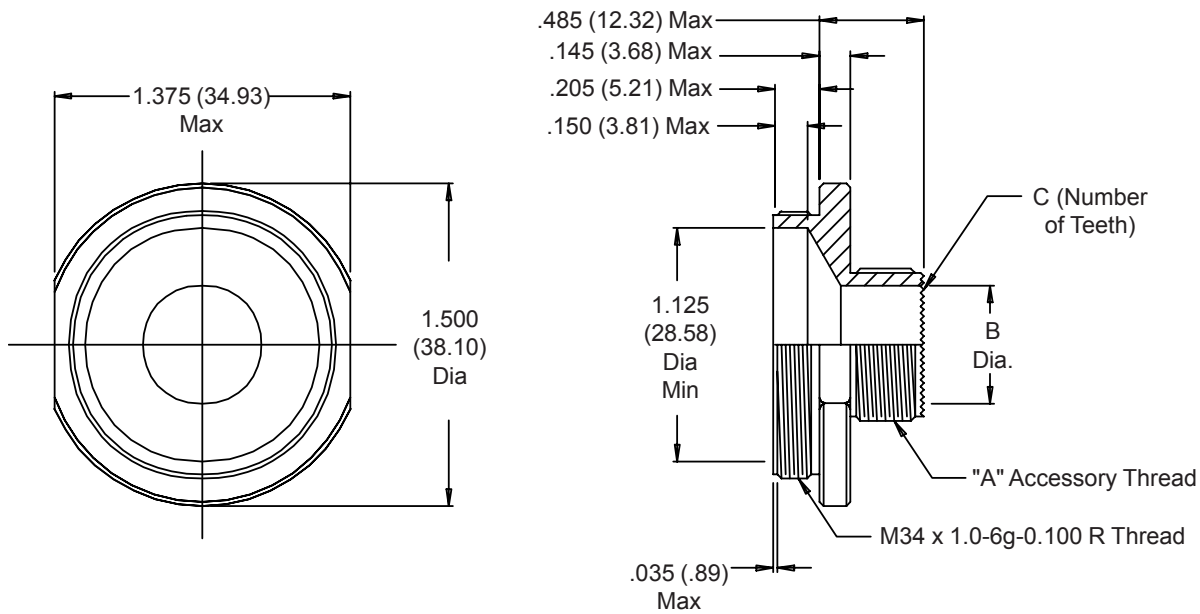

TABLE I

Shell Size	"A" Accessory Thread	B Dia ±.005 (0.13)	C Number of Teeth
09	M12x1.0-6g 0.100R	.332 (8.18)	12
11	M15x1.0-6g 0.100R	.440 (11.18)	16
13	M18x1.0-6g 0.100R	.559 (14.20)	20
15	M22x1.0-6g 0.100R	.716 (18.19)	24
17	M25x1.0-6g 0.100R	.834 (21.18)	28
19	M28x1.0-6g 0.100R	.952 (24.18)	32
21	M31x1.0-6g 0.100R	1.070 (27.18)	36
23	M34x1.0-6g 0.100R	1.188 (30.18)	40

1. For complete dimensions see applicable Military Specification.
2. Material is corrosion resistant steel.
3. Metric dimensions (mm) are indicated in parentheses.

AS85049/34 Adapters/Extenders



Adapter/
Extender
Backshells

Glenair Connector
Designator D

MIL-C-26482 Series 1

For Use With
MS3114 and MS3124
Connectors Only

M85049/34-12 W

Basic Part No.

Finish

W = 500 Hr. Cadmium Olive Drab
Over Electroless Nickel

Shell Size

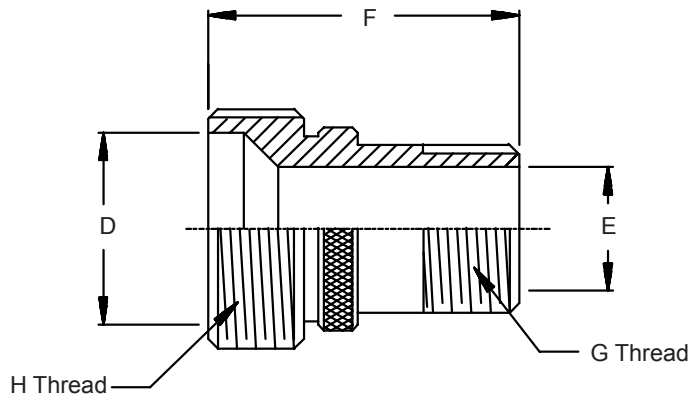
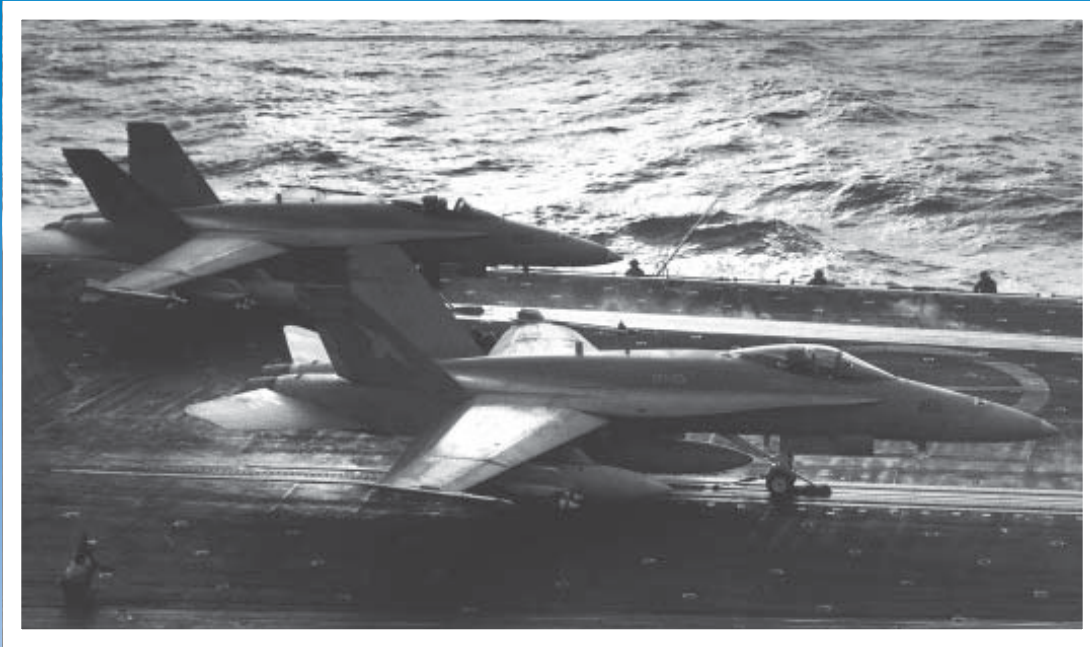

TABLE I

Shell Size	D Dia	E Dia	F Max	G Thread UNEF Class 2A	H Thread UNEF Class 2A
8	.500 (12.7)	.327 (8.3)	.812 (20.6)	.4375 - 28	.625 - 24
10	.609 (15.5)	.444 (11.3)	.812 (20.6)	.5625 - 24	.750 - 20
12	.734 (18.6)	.569 (14.5)	.812 (20.6)	.6875 - 24	.875 - 20
14	.859 (21.8)	.673 (17.1)	.812 (20.6)	.8125 - 20	1.000 - 20
16	.969 (24.6)	.798 (20.3)	.812 (20.6)	.9375 - 20	1.125 - 18
18	1.109 (28.2)	.915 (23.2)	.812 (20.6)	1.0625 - 18	1.250 - 18
20	1.219 (31.0)	1.030 (26.2)	.906 (23.0)	1.1875 - 18	1.375 - 18
22	1.344 (34.1)	1.155 (29.3)	.906 (23.0)	1.3125 - 18	1.500 - 18
24	1.469 (37.3)	1.280 (32.5)	.937 (23.8)	1.4375 - 18	1.625 - 18

1. For complete dimensions see applicable Military Specification.
2. Metric dimensions (mm) are indicated in parentheses.

Corrosion resistance and weight reduction high on your list?



Upgrade to Glenair's composite thermoplastic backshells and accessories.

For most applications, backshells and accessories made from aluminum, stainless and carbon steel are recommended. But for applications where additional weight savings and corrosion resistance are required, many customers are now specifying composite thermoplastic materials.

Glenair is the recognized leader in composite thermoplastic research and development for the interconnect accessory industry. In fact, no one else has tooled even a small fraction of the composite products available today from Glenair—in stock and ready for same-day shipment.



Commercial and Mil Spec connector accessories



Convolved tubing and metal-core conduit



Electrical and fiber optic cable assemblies



Composite thermoplastic components



Microminiature connectors and accessories



Backshell assembly and termination tools



1211 Air Way
Glendale, California 91201-2497

Telephone: 818-247-6000 · Facsimile: 818-500-9912 · EMail: sales@glenair.com

United States · United Kingdom · Germany · Nordic · France · Italy · Spain
www.glenair.com

Non-Environmental Strain Relief Backshells



Non-Environmental Backshells

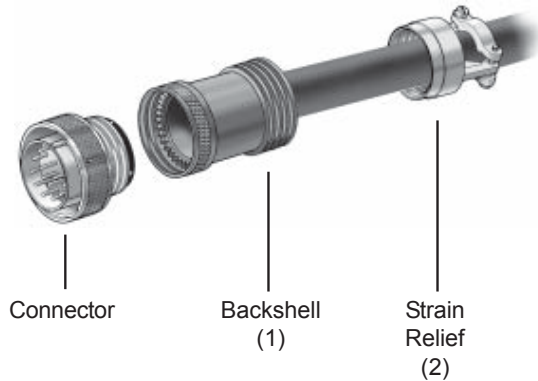

Straight backshells are combined with a variety of strain reliefs to provide cable to connector protection in situations where environmental sealing is not required.

Military Specification	Superceding Part Number	Glenair's Commercial Catalog P/N	Description	Glenair Connector Designator	Page Number
M38999/6	M85049/29	360FS002	Non-Env. Strain Relief	F	36-5*
M83723/35A		**	90° Non-Env. Strain Relief	K	36-2
M83723/35S		**	Non-Env. Strain Relief	K	36-3
AS85049/21		360HS002	Non-Env. Strain Relief	H	36-4
AS85049/29		360FS002	Non-Env. Strain Relief	F	36-5

* Page Number of Superceding Part Number
 ** Consult Factory

Assembly Instructions

The following suggested procedure serves as a guide for proper assembly and installation of Glenair Non-Environmental Backshells. It is recommended that trial samples of appropriate cables or wire bundles be used to determine proper trim dimensions of the individual conductors and cable jackets, if applicable.

- a. Temporarily assemble backshell (1) to connector.
- b. If cable is jacketed, insert cable into backshell (1) and bottom against connector. Hold cable in position and mark cable jacket at rear end of backshell.
- c. Remove backshell from connector and place on cable with strain relief (2).
- d. Trim cable jacket at a point 1/2 inch toward connector from mark made in step (b) above.
- e. Prepare and terminate cable conductors in accordance with established practices.
- f. Assemble backshell (1) to connector and tighten securely.
- g. Assemble strain relief (2) to backshell and tighten securely. Tighten strain relief saddles securely on cable or harness.

NOTE: As with any electrical connector assembly procedure, be sure to use the proper tools. For convenient, reliable assembly of the connectors and backshells, it is suggested that Glenair's connector holding tools, strap wrenches and connector pliers be used.



M83723/35A Non-Environmental Strain Relief Backshells

Glenair Connector
Designator K

MIL-DTL-83723 Series II

M83723/35A 22 A

Basic Part No. _____

Dash No. _____

Finish:

A = Black Anodize

R = Electroless Nickel

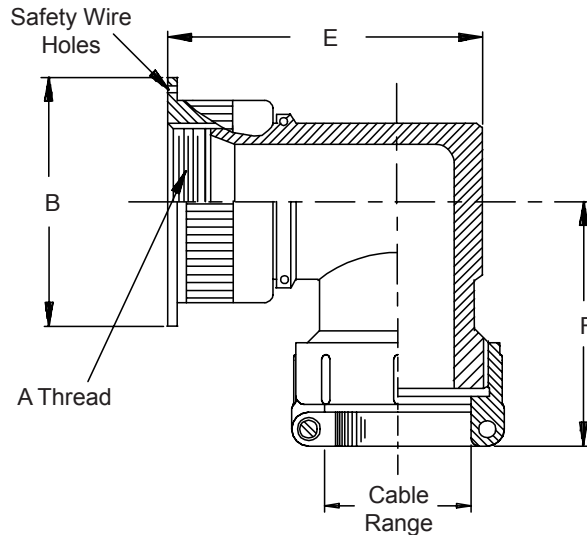

TABLE I

Dash No.	A Thread Class 2B	B Dia Max	E Max	F Max	Cable Range		
					Min	Max	Max
08	.438 - 28 UNEF	.805 (20.4)	1.187 (30.1)	1.220 (31.0)	.102 (2.6)	.235 (6.0)	
10	.500 - 28 UNEF	.890 (22.6)	1.187 (30.1)	1.250 (31.8)	.102 (2.6)	.235 (6.0)	
11	.562 - 24 UNEF	.975 (24.8)	1.312 (33.3)	1.280 (32.5)	.140 (3.6)	.297 (7.5)	
13	.625 - 24 UNEF	1.005 (25.5)	1.312 (33.3)	1.280 (32.5)	.140 (3.6)	.297 (7.5)	
12	.625 - 24 UNEF	1.005 (25.5)	1.468 (37.3)	1.280 (32.5)	.140 (3.6)	.297 (7.5)	
15	.750 - 20 UNEF	1.130 (28.7)	1.437 (36.5)	1.405 (35.7)	.195 (5.0)	.422 (10.7)	
14	.750 - 20 UNEF	1.130 (28.7)	1.594 (40.5)	1.405 (35.7)	.195 (5.0)	.422 (10.7)	
17	.875 - 20 UNEF	1.255 (31.9)	1.531 (38.9)	1.529 (38.8)	.255 (6.5)	.547 (13.9)	
16	.875 - 20 UNEF	1.255 (31.9)	1.687 (42.8)	1.529 (38.8)	.255 (6.5)	.547 (13.9)	
18	1.000 - 20 UNEF	1.350 (34.3)	1.765 (44.8)	1.593 (40.5)	.285 (7.2)	.610 (15.5)	
20	1.125 - 18 UNEF	1.475 (37.5)	2.000 (50.8)	1.655 (42.0)	.350 (8.9)	.735 (18.7)	
22	1.250 - 18 UNEF	1.600 (40.6)	2.000 (50.8)	1.718 (43.6)	.350 (8.9)	.735 (18.7)	
24	1.375 - 18 UNEF	1.725 (43.8)	2.265 (57.5)	1.894 (48.1)	.468 (11.9)	.922 (23.4)	
28	1.625 - 18 UNEF	1.975 (50.2)	2.265 (57.5)	1.973 (50.1)	.468 (11.9)	.922 (23.4)	
32	1.875 - 16 UN	2.225 (56.5)	2.578 (65.5)	2.187 (55.5)	.664 (16.9)	1.235 (31.4)	
36	2.125 - 16 UN	2.475 (62.9)	2.815 (71.5)	2.405 (61.1)	.694 (17.6)	1.360 (34.5)	
40	2.375 - 16 UN	2.750 (69.9)	5.800 (147.3)	5.100 (129.5)	.911 (23.1)	1.630 (41.4)	

1. For complete dimensions see applicable Military Specification.
2. Metric dimensions (mm) are indicated in parentheses.
3. Cable range is defined as the accommodation range for the wire bundle or cable. Dimensions shown are not intended for inspection criteria.

M83723/35S Non-Environmental Strain Relief Backshells



Non-Environmental Backshells

Glenair Connector Designator K

MIL-DTL-83723 Series II

M83723/35S 22 A
 Basic Part No. _____
 Dash No. _____
 Finish:
 A = Black Anodize
 R = Electroless Nickel

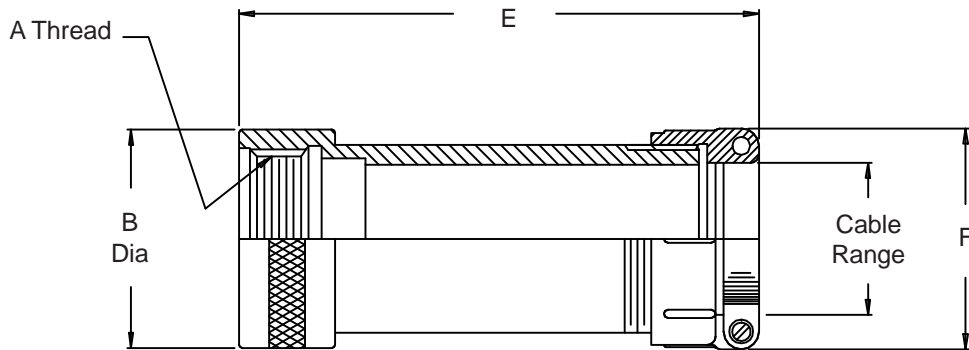

TABLE I

Dash No.	Shell Size(s) Ref	A Thread Class 2B	B Dia Max	E Max	F Max	Cable Range	
						Min	Max
08	8S	.438 - 28 UNEF	.59 (15.0)	1.290 (32.8)	.843 (21.4)	.125 (3.2)	.235 (6.0)
10	10S	.500 - 28 UNEF	.65 (16.5)	1.290 (32.8)	.843 (21.4)	.125 (3.2)	.235 (6.0)
11	10SL	.562 - 24 UNEF	.73 (18.5)	1.290 (32.8)	.906 (23.0)	.170 (4.3)	.287 (7.3)
13	12 & 12S	.625 - 24 UNEF	.77 (19.6)	1.290 (32.8)	1.085 (27.6)	.170 (4.3)	.297 (7.5)
15	14 & 14S	.750 - 20 UNEF	.91 (23.1)	1.368 (34.7)	1.093 (27.8)	.235 (6.0)	.422 (10.7)
16	16	.875 - 20 UNEF	1.03 (26.2)	1.587 (40.3)	1.275 (32.4)	.295 (7.5)	.547 (13.9)
17	16S	.875 - 20 UNEF	1.03 (26.2)	1.430 (36.3)	1.187 (30.1)	.295 (7.5)	.547 (13.9)
18	18	1.000 - 20 UNEF	1.17 (29.7)	1.695 (43.1)	1.475 (37.5)	.325 (8.3)	.610 (15.5)
20	20	1.125 - 18 UNEF	1.30 (33.0)	1.695 (43.1)	1.500 (38.1)	.380 (9.7)	.735 (18.7)
22	22	1.250 - 18 UNEF	1.42 (36.1)	1.695 (43.1)	1.710 (43.4)	.380 (9.7)	.735 (18.7)
24	24	1.375 - 18 UNEF	1.53 (38.9)	1.931 (49.0)	1.719 (43.7)	.500 (12.7)	.922 (23.4)
28	28	1.625 - 18 UNEF	1.80 (45.7)	1.931 (49.0)	2.040 (51.8)	.500 (12.7)	.922 (23.4)
32	32	1.875 - 16 UN	2.04 (51.8)	1.869 (47.5)	2.332 (59.2)	.705 (17.9)	1.235 (31.4)
36	36	2.125 - 16 UN	2.27 (57.7)	1.869 (47.5)	2.312 (58.7)	.725 (18.4)	1.360 (34.5)
40	40	2.375 - 16 UN	2.78 (70.6)	2.875 (73.0)	2.950 (74.9)	.911 (23.1)	1.630 (41.4)

1. For complete dimensions see applicable Military Specification.
2. Metric dimensions (mm) are indicated in parentheses.
3. Cable range is defined as the accommodation range for the wire bundle or cable. Dimensions shown are not intended for inspection criteria.



AS85049/21 Non-Environmental Strain Relief Backshells

**Glenair Connector
Designator H**

**MIL-DTL-38999
Series III & IV,
EN3645**

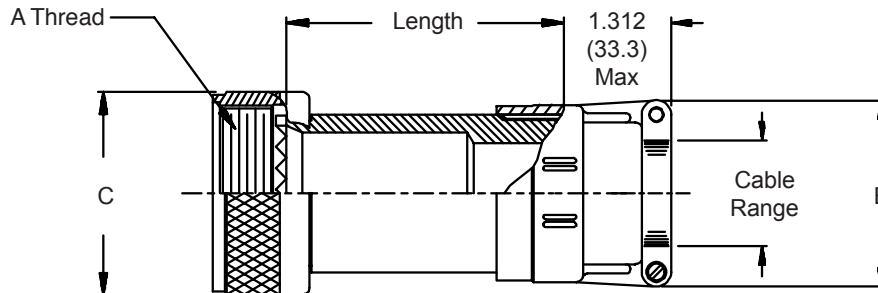
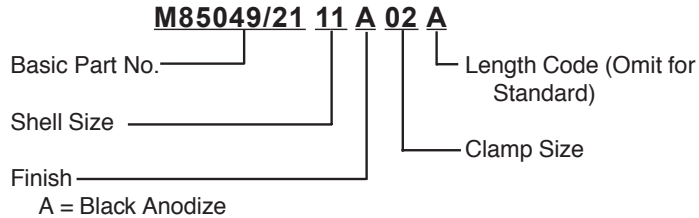

Shell Size	Clamp Size (Table IV)		A Thread Class 2B	C Dia Max
	Min	Max		
9	01	02	M12 X 1 - 6H	.75 (19.1)
11	01	03	M15 X 1 - 6H	.85 (21.6)
13	02	04	M18 X 1 - 6H	1.00 (25.4)
15	02	05	M22 X 1 - 6H	1.10 (27.9)
17	02	06	M25 X 1 - 6H	1.25 (31.8)
19	03	07	M28 X 1 - 6H	1.40 (35.6)
21	03	08	M31 X 1 - 6H	1.50 (38.1)
23	03	09	M34 X 1 - 6H	1.65 (41.9)
25	04	10	M37 X 1 - 6H	1.75 (44.5)

Clamp Size	Cable Range		E Max
	Min	Max	
01	.062 (1.6)	.125 (3.2)	.80 (20.3)
02	.125 (3.2)	.250 (6.4)	1.00 (25.4)
03	.250 (6.4)	.375 (9.5)	1.10 (27.9)
04	.312 (7.9)	.500 (12.7)	1.20 (30.5)
05	.437 (11.1)	.625 (15.9)	1.25 (31.8)
06	.562 (14.3)	.750 (19.1)	1.40 (35.6)
07	.687 (17.4)	.875 (22.2)	1.50 (38.1)
08	.812 (20.6)	1.000 (25.4)	1.65 (41.9)
09	.937 (23.8)	1.125 (28.6)	1.75 (44.5)
10	1.062 (27.0)	1.250 (31.8)	1.90 (48.3)

1. For complete dimensions see applicable Military Specification.
2. Metric dimensions (mm) are indicated in parentheses.
3. Cable range is defined as the accommodation range for the wire bundle or cable. Dimensions shown are not intended for inspection criteria.

Length Code	Available Shell Sizes	Length
Std.	09 - 25	1.500 (38.1)
A	09 - 25	2.500 (63.5)
B	15 - 25	3.500 (88.9)
C	21 - 25	4.500 (114.3)

AS85049/29 Non-Environmental Strain Relief Backshells



Non-Environmental Backshells

Glenair Connector Designator F

MIL-DTL-38999 Series I & II, 40M38277, PAN 6433-1, PATT 614, PATT 616, NFC93422 Series HE308 & HE309

M85049/29 10 N 03 A

Basic Part No. _____ Length Code (Omit for Standard)
 Shell Size _____ Clamp Size
 Finish _____
 A = Black Anodize
 N = Electroless Nickel
 W = 1,000 Hr. Cadmium Olive Drab Over Electroless Nickel

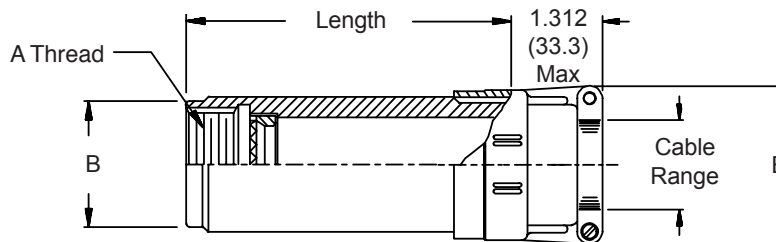

Shell Size	Series I Ref.	Clamp Size (Table II)		A Thread Class 2B	B Dia +.000 (-0.062)
		Min	Max		
08	09	01	02	.438 - 28 UNEF	.567 (14.4)
10	11	01	03	.562 - 24 UNEF	.704 (17.9)
12	13	02	04	.688 - 24 UNEF	.829 (21.1)
14	15	02	05	.813 - 20 UNEF	.954 (24.2)
16	17	02	06	.938 - 20 UNEF	1.079 (27.4)
18	19	03	07	1.063 - 18 UNEF	1.203 (30.6)
20	21	03	08	1.188 - 18 UNEF	1.329 (33.8)
22	23	03	09	1.313 - 18 UNEF	1.454 (36.9)
24	25	04	10	1.438 - 18 UNEF	1.579 (40.1)

Clamp Size	Cable Range		E Max
	Min	Max	
01	.062 (1.6)	.125 (3.2)	.781 (19.8)
02	.125 (3.2)	.250 (6.4)	.969 (24.6)
03	.250 (6.4)	.375 (9.5)	1.062 (27.0)
04	.312 (7.9)	.500 (12.7)	1.156 (29.4)
05	.437 (11.1)	.625 (15.9)	1.250 (31.8)
06	.562 (14.3)	.750 (19.1)	1.375 (34.9)
07	.687 (17.4)	.875 (22.2)	1.500 (38.1)
08	.812 (20.6)	1.000 (25.4)	1.625 (41.3)
09	.937 (23.8)	1.125 (28.6)	1.750 (44.5)
10	1.062 (27.0)	1.250 (31.8)	1.875 (47.6)

- For complete dimensions see applicable Military Specification.
- Metric dimensions (mm) are indicated in parentheses.
- Cable range is defined as the accommodation range for the wire bundle or cable. Dimensions shown are not intended for inspection criteria.

Length Code	Available Shell Sizes	Length
Std.	08 - 24	1.00 (25.4)
A	08 - 24	2.00 (50.8)
B	14 - 24	3.00 (76.2)
C	20 - 24	4.00 (101.6)

Still juggling an army of interconnect suppliers?



At Glenair we offer One-Stop-Shopping

Tired of managing dozens of specialty suppliers with only limited ability to keep pace with your evolving interconnect requirements? Glenair is committed to providing complete, system-level solutions to even your most challenging interconnect requirements. Our expertise extends well beyond discrete backshells and connec-

tors to encompass the entire range of interconnect components and assembled systems. From conduit systems to overmolded cable assemblies, Glenair is ready with a truly broad mix of interconnect products and assembly services. And best of all, many Glenair products are in stock, ready for immediate same-day shipment.



Commercial and Mil Spec connector accessories



Convolved tubing and metal-core conduit



Electrical and fiber optic cable assemblies



Composite thermoplastic components



Microminiature connectors and accessories



Backshell assembly and termination tools



1211 Air Way
Glendale, California 91201-2497
Telephone: 818-247-6000 · Facsimile: 818-500-9912 · EMail: sales@glenair.com

United States · United Kingdom · Germany · Nordic · France · Italy · Spain

www.glenair.com

Environmental Backshells



Environmental Backshells

Glenair Environmental Backshells offer excellent immersion capability when used with impervious jacketed cables. A resilient grommet which fits into a counterbore in the backshell compresses and seals against the cable jacket when the strain relief is tightened.

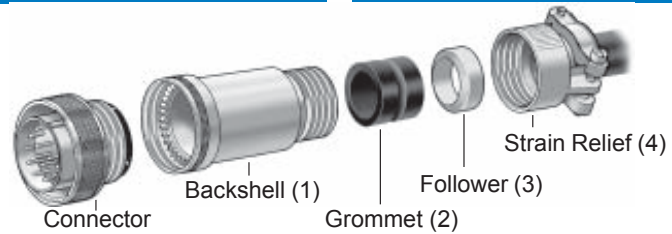

Military Specification	Superceeding Part Number	Glenair's Commercial Catalog P/N	Description	Glenair Connector Designator	Page Number
MS3188B	M85049/9	370AA001	90° Env. Backshell	A	37-22
MS3189B	M85049/7	370AB001	45° Env. Backshell	A	37-20
MS3437B	M85049/11	370AS001	Str. Env. Backshell	A	37-24
M28840/6 B		**	Str. Env. Backshell	G	37-2
M28840/8 B		**	90° Env. Backshell	G	37-3
M28840/9 B		**	45° Env. Backshell	G	37-4
AS85049/3 1		**	Str. Env. Backshell	C	37-5
AS85049/3 2		**	Str. Env. Backshell	C	37-6
AS85049/3 3		**	Str. Env. Backshell	C	37-7
AS85049/4 1		**	Str. Env. Backshell	C	37-8
AS85049/4 2		**	Str. Env. Backshell	C	37-10
AS85049/4 3		**	Str. Env. Backshell	C	37-12
AS85049/5 1		**	Str. Env. Backshell	C	37-14
AS85049/5 2		**	Str. Env. Backshell	C	37-16
AS85049/5 3		**	Str. Env. Backshell	C	37-18
AS85049/7		370AB001	45° Env. Backshell	A	37-20
AS85049/9		370AA001	90° Env. Backshell	A	37-22
AS85049/11		370AS001	Str. Env. Backshell	A	37-24

** Consult Factory

Assembly Instructions

The following suggested procedure serves as a guide for proper assembly and installation of straight Glenair Environmental Backshells for use with jacketed cables. It is recommended that trial samples of appropriate cables be used to determine proper trim dimensions of the cable jacket and individual conductors.

- Temporarily assemble backshell (1) to connector.
- Place grommet (2), follower (3), and strain relief (4) on cable in sequence shown. Keep these components at a convenient distance from the end of the cable so they will not interfere with subsequent assembly steps.
- Insert cable into backshell (1) and bottom against connector. Hold cable in position and mark cable jacket at rear end of backshell.
- Remove backshell from connector and place on cable with components in step (b) above.
- Trim cable jacket at mark in step (c) above. Depending on type of connector contact termination used (solder,

crimp, etc.) the length of individual conductors may require shortening by 3/4 inch to assure that the cable jacket will be in proper position when grommet (2) is clamped and compressed.

- Prepare and terminate cable conductors in accordance with established practices.
- Assemble backshell (1) to connector and tighten securely. Slide grommet (2) into backshell and position follower (3) against grommet.
- Attach strain relief (4) to backshell and tighten securely. If provided, tighten strain relief saddles securely on cable jacket.

NOTE: As with any electrical connector assembly procedure, be sure to use the proper tools. For convenient reliable assembly of the connector and backshell, it is suggested that Glenair's connector holding tools, strap wrenches and connector pliers be used.



M28840/6 B Environmental Backshells

Glenair Connector Designator G

MIL-C-28840

M28840/6 16 W B

Basic Part No. ————
 Dash No. (Table II) ————
 Style Designator - B = Environmental
 Material and Finish Designator
 D = Corrosion Resistant Steel,
 Cadmium Plate, Black
 W = Aluminum, Cadmium Olive
 Drab over Electroless Nickel

Shell Size	A Thread Class 2B	C Dia Max
11	.750 - 20 UNEF	1.03 (26.2)
13	.875 - 20 UNEF	1.14 (29.0)
15	1.000 - 20 UNEF	1.26 (32.0)
17	1.125 - 18 UNEF	1.39 (35.3)
19	1.250 - 18 UNEF	1.51 (38.4)
23	1.438 - 18 UNEF	1.70 (43.2)
25	1.563 - 18 UNEF	1.82 (46.2)
29	1.875 - 16 UN	2.14 (54.4)
33	2.063 - 16 UNS	2.33 (59.2)

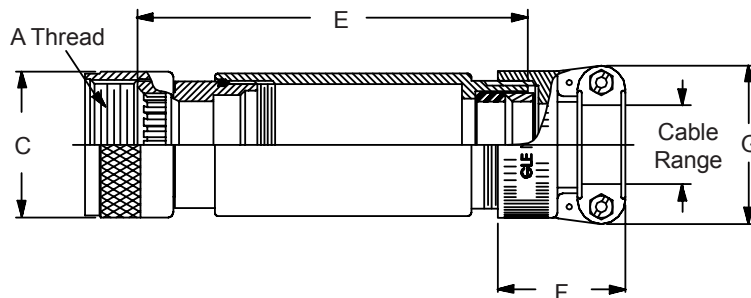

Dash No.	Shell Size Ref.	E		F Ref. Dim	G Ref. Dim	Cable Range	
		±.12	(3.0)			Min	Max
01	11	3.62	(91.9)	1.281 (32.5)	.938 (23.8)	.188 (4.8)	.312 (7.9)
02	13	3.62	(91.9)	1.281 (32.5)	.938 (23.8)	.188 (4.8)	.312 (7.9)
03	13	3.62	(91.9)	1.281 (32.5)	1.125 (28.6)	.281 (7.1)	.438 (11.1)
04	15	3.62	(91.9)	1.281 (32.5)	.938 (23.8)	.188 (4.8)	.312 (7.9)
05	15	3.62	(91.9)	1.281 (32.5)	1.125 (28.6)	.281 (7.1)	.438 (11.1)
06	15	3.62	(91.9)	1.281 (32.5)	1.312 (33.3)	.344 (8.7)	.562 (14.3)
07	15	4.12	(104.6)	1.312 (33.3)	1.593 (40.5)	.438 (11.1)	.750 (19.1)
08	17	4.12	(104.6)	1.281 (32.5)	1.312 (33.3)	.375 (9.5)	.625 (15.9)
09	17	4.12	(104.6)	1.312 (33.3)	1.593 (40.5)	.438 (11.1)	.750 (19.1)
10	17	4.12	(104.6)	1.406 (35.7)	1.750 (44.5)	.625 (15.9)	.938 (23.8)
11	19	4.12	(104.6)	1.281 (32.5)	1.312 (33.3)	.375 (9.5)	.625 (15.9)
12	19	4.12	(104.6)	1.406 (35.7)	1.750 (44.5)	.625 (15.9)	.938 (23.8)
13	23	4.62	(117.3)	1.312 (33.3)	1.593 (40.5)	.438 (11.1)	.750 (19.1)
14	23	4.62	(117.3)	1.406 (35.7)	1.750 (44.5)	.625 (15.9)	.938 (23.8)
15	23	4.62	(117.3)	1.593 (40.5)	2.093 (53.2)	.812 (20.6)	1.188 (30.2)
16	25	4.62	(117.3)	1.406 (35.7)	1.750 (44.5)	.625 (15.9)	.938 (23.8)
17	25	5.12	(130.0)	1.593 (40.5)	2.093 (53.2)	.812 (20.6)	1.188 (30.2)
18	25	5.12	(130.0)	1.593 (40.5)	2.093 (53.2)	.875 (22.2)	1.250 (31.8)
19	25	5.12	(130.0)	1.625 (41.3)	2.343 (59.5)	1.000 (25.4)	1.380 (35.1)
20	29	5.12	(130.0)	1.593 (40.5)	2.093 (53.2)	.812 (20.6)	1.188 (30.2)
21	29	5.12	(130.0)	1.625 (41.3)	2.343 (59.5)	1.000 (25.4)	1.380 (35.1)
22	33	5.12	(130.0)	1.625 (41.3)	2.343 (59.5)	1.000 (25.4)	1.380 (35.1)
23	33	5.12	(130.0)	1.900 (48.3)	2.750 (69.9)	1.250 (31.8)	1.625 (41.3)
24	11	3.62	(91.9)	1.281 (32.5)	1.125 (28.6)	.281 (7.1)	.438 (11.1)
25	11	3.62	(91.9)	1.281 (32.5)	1.312 (33.3)	.344 (8.7)	.562 (14.3)
26	13	3.62	(91.9)	1.281 (32.5)	1.312 (33.3)	.344 (8.7)	.562 (14.3)
27	13	4.12	(104.6)	1.281 (32.5)	1.312 (33.3)	.375 (9.5)	.625 (15.9)
28	15	4.12	(104.6)	1.281 (32.5)	1.312 (33.3)	.375 (9.5)	.625 (15.9)

1. For complete dimensions see applicable Military Specification.
2. Metric dimensions (mm) are indicated in parentheses.
3. Cable range is defined as the accommodations range for the wire bundle or cable. Dimensions shown are not intended for inspection criteria.

M28840/8 B Environmental Backshells



Environmental Backshells

Glenair Connector Designator **G**

MIL-C-28840

M28840/8 16 W B

Basic Part No.

Dash No. (Table II)

Style Designator - B = Environmental

Material and Finish Designator

D = Corrosion Resistant Steel, Cadmium Plate, Black

W = Aluminum, Cadmium Olive Drab over Electroless Nickel

TABLE I

Shell Size	A Thread Class 2B	C Dia Max
11	.750 - 20 UNEF	1.03 (26.2)
13	.875 - 20 UNEF	1.14 (29.0)
15	1.000 - 20 UNEF	1.26 (32.0)
17	1.125 - 18 UNEF	1.39 (35.3)
19	1.250 - 18 UNEF	1.51 (38.4)
23	1.438 - 18 UNEF	1.70 (43.2)
25	1.563 - 18 UNEF	1.82 (46.2)
29	1.875 - 16 UN	2.14 (54.4)
33	2.063 - 16 UNS	2.33 (59.2)

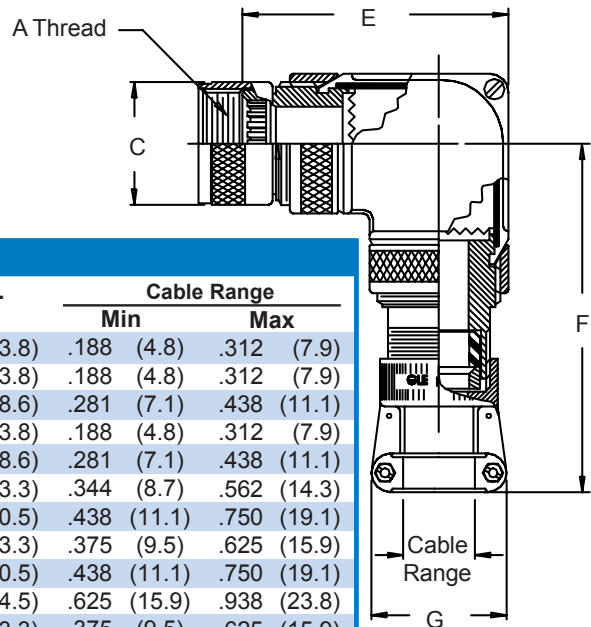

TABLE II

Dash No.	Shell Size Ref.	E Max Envelope	F Max	G Ref. Dim	Cable Range	
					Min	Max
01	11	2.614 (66.4)	2.962 (75.2)	.938 (23.8)	.188 (4.8)	.312 (7.9)
02	13	2.614 (66.4)	2.962 (75.2)	.938 (23.8)	.188 (4.8)	.312 (7.9)
03	13	2.614 (66.4)	2.962 (75.2)	1.125 (28.6)	.281 (7.1)	.438 (11.1)
04	15	2.864 (72.7)	3.087 (78.4)	.938 (23.8)	.188 (4.8)	.312 (7.9)
05	15	2.864 (72.7)	3.087 (78.4)	1.125 (28.6)	.281 (7.1)	.438 (11.1)
06	15	2.864 (72.7)	3.087 (78.4)	1.312 (33.3)	.344 (8.7)	.562 (14.3)
07	15	3.114 (79.1)	3.312 (84.1)	1.593 (40.5)	.438 (11.1)	.750 (19.1)
08	17	3.114 (79.1)	3.312 (84.1)	1.312 (33.3)	.375 (9.5)	.625 (15.9)
09	17	3.114 (79.1)	3.343 (84.9)	1.593 (40.5)	.438 (11.1)	.750 (19.1)
10	17	3.114 (79.1)	3.437 (87.3)	1.750 (44.5)	.625 (15.9)	.938 (23.8)
11	19	3.114 (79.1)	3.312 (84.1)	1.312 (33.3)	.375 (9.5)	.625 (15.9)
12	19	3.364 (85.4)	3.462 (87.9)	1.750 (44.5)	.625 (15.9)	.938 (23.8)
13	23	3.364 (85.4)	3.368 (85.5)	1.593 (40.5)	.438 (11.1)	.750 (19.1)
14	23	3.364 (85.4)	3.462 (87.9)	1.750 (44.5)	.625 (15.9)	.938 (23.8)
15	23	3.364 (85.4)	3.649 (92.7)	2.093 (53.2)	.812 (20.6)	1.188 (30.2)
16	25	3.364 (85.4)	3.462 (87.9)	1.750 (44.5)	.625 (15.9)	.938 (23.8)
17	25	3.364 (85.4)	3.649 (92.7)	2.093 (53.2)	.812 (20.6)	1.188 (30.2)
18	25	3.614 (91.8)	3.774 (95.9)	2.093 (53.2)	.875 (22.2)	1.250 (31.8)
19	25	3.614 (91.8)	3.806 (96.7)	2.343 (59.5)	1.000 (25.4)	1.380 (35.1)
20	29	3.614 (91.8)	3.774 (95.9)	2.093 (53.2)	.812 (20.6)	1.188 (30.2)
21	29	3.614 (91.8)	3.806 (96.7)	2.343 (59.5)	1.000 (25.4)	1.380 (35.1)
22	33	4.114 (104.5)	4.056 (103.0)	2.343 (59.5)	1.000 (25.4)	1.380 (35.1)
23	33	4.114 (104.5)	4.331 (110.0)	2.750 (69.9)	1.250 (31.8)	1.625 (41.3)
24	11	2.614 (66.4)	2.962 (75.2)	1.125 (28.6)	.281 (7.1)	.438 (11.1)
25	11	2.864 (72.7)	3.087 (78.4)	1.312 (33.3)	.344 (8.7)	.562 (14.3)
26	13	2.864 (72.7)	3.087 (78.4)	1.312 (33.3)	.344 (8.7)	.562 (14.3)
27	13	3.114 (79.1)	3.312 (84.1)	1.312 (33.3)	.375 (9.5)	.625 (15.9)
28	15	3.114 (79.1)	3.312 (84.1)	1.312 (33.3)	.375 (9.5)	.625 (15.9)

- For complete dimensions see applicable Military Specification.
- Metric dimensions (mm) are indicated in parentheses.
- Cable range is defined as the accommodations range for the wire bundle or cable. Dimensions shown are not intended for inspection criteria.

AS28840/9 B Environmental Backshells

Glenair Connector Designator G

MIL-C-28840

M28840/9 16 W B

Basic Part No.

Style Designator - B = Environmental

Dash No. (Table II)

Material and Finish Designator
D = Corrosion Resistant Steel,
Cadmium Plate, Black
W = Aluminum, Cadmium Olive
Drab over Electroless Nickel

TABLE I

Shell Size	A Thread Class 2B	C Dia Max
11	.750 - 20 UNEF	1.03 (26.2)
13	.875 - 20 UNEF	1.14 (29.0)
15	1.000 - 20 UNEF	1.26 (32.0)
17	1.125 - 18 UNEF	1.39 (35.3)
19	1.250 - 18 UNEF	1.51 (38.4)
23	1.438 - 18 UNEF	1.70 (43.2)
25	1.563 - 18 UNEF	1.82 (46.2)
29	1.875 - 16 UN	2.14 (54.4)
33	2.063 - 16 UNS	2.33 (59.2)

- For complete dimensions see applicable Military Specification.
- Metric dimensions (mm) are indicated in parentheses.
- Cable range is defined as the accommodations range for the wire bundle or cable. Dimensions shown are not intended for inspection criteria.

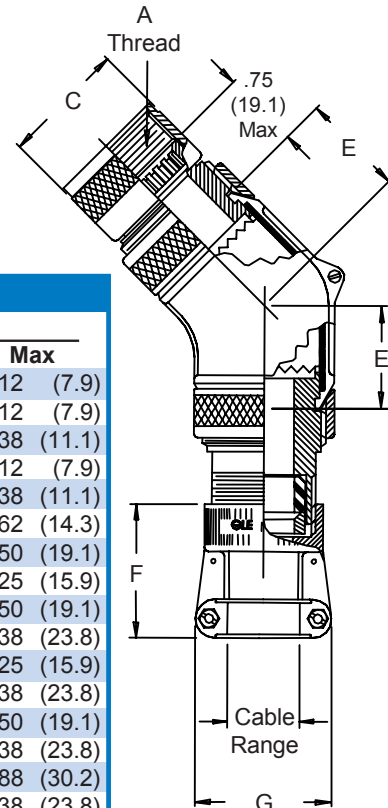

TABLE II

Dash No.	Shell Size Ref.	E Max	F Ref. Dim	G Ref. Dim	Cable Range		
					Min	Max	
01	11	1.031 (26.2)	1.281 (32.5)	.938 (23.8)	.188 (4.8)	.312 (7.9)	
02	13	1.031 (26.2)	1.281 (32.5)	.938 (23.8)	.188 (4.8)	.312 (7.9)	
03	13	1.031 (26.2)	1.281 (32.5)	1.125 (28.6)	.281 (7.1)	.438 (11.1)	
04	15	1.156 (29.4)	1.281 (32.5)	.938 (23.8)	.188 (4.8)	.312 (7.9)	
05	15	1.156 (29.4)	1.281 (32.5)	1.125 (28.6)	.281 (7.1)	.438 (11.1)	
06	15	1.156 (29.4)	1.281 (32.5)	1.312 (33.3)	.344 (8.7)	.562 (14.3)	
07	15	1.281 (32.5)	1.312 (33.3)	1.593 (40.5)	.438 (11.1)	.750 (19.1)	
08	17	1.281 (32.5)	1.281 (32.5)	1.312 (33.3)	.375 (9.5)	.625 (15.9)	
09	17	1.281 (32.5)	1.312 (33.3)	1.593 (40.5)	.438 (11.1)	.750 (19.1)	
10	17	1.281 (32.5)	1.406 (35.7)	1.750 (44.5)	.625 (15.9)	.938 (23.8)	
11	19	1.281 (32.5)	1.281 (32.5)	1.312 (33.3)	.375 (9.5)	.625 (15.9)	
12	19	1.406 (35.7)	1.406 (35.7)	1.750 (44.5)	.625 (15.9)	.938 (23.8)	
13	23	1.406 (35.7)	1.312 (33.3)	1.593 (40.5)	.438 (11.1)	.750 (19.1)	
14	23	1.406 (35.7)	1.406 (35.7)	1.750 (44.5)	.625 (15.9)	.938 (23.8)	
15	23	1.406 (35.7)	1.593 (40.5)	2.093 (53.2)	.812 (20.6)	1.188 (30.2)	
16	25	1.406 (35.7)	1.406 (35.7)	1.750 (44.5)	.625 (15.9)	.938 (23.8)	
17	25	1.406 (35.7)	1.593 (40.5)	2.093 (53.2)	.812 (20.6)	1.188 (30.2)	
18	25	1.531 (38.9)	1.593 (40.5)	2.093 (53.2)	.875 (22.2)	1.250 (31.8)	
19	25	1.531 (38.9)	1.625 (41.3)	2.343 (59.5)	1.000 (25.4)	1.380 (35.1)	
20	29	1.531 (38.9)	1.593 (40.5)	2.093 (53.2)	.812 (20.6)	1.188 (30.2)	
21	29	1.531 (38.9)	1.625 (41.3)	2.343 (59.5)	1.000 (25.4)	1.380 (35.1)	
22	33	1.781 (45.2)	1.625 (41.3)	2.343 (59.5)	1.000 (25.4)	1.380 (35.1)	
23	33	1.781 (45.2)	1.900 (48.3)	2.750 (69.9)	1.250 (31.8)	1.625 (41.3)	
24	11	1.031 (26.2)	1.281 (32.5)	1.125 (28.6)	.281 (7.1)	.438 (11.1)	
25	11	1.156 (29.4)	1.281 (32.5)	1.312 (33.3)	.344 (8.7)	.562 (14.3)	
26	13	1.156 (29.4)	1.281 (32.5)	1.312 (33.3)	.344 (8.7)	.562 (14.3)	
27	13	1.281 (32.5)	1.281 (32.5)	1.312 (33.3)	.375 (9.5)	.625 (15.9)	
28	15	1.281 (32.5)	1.281 (32.5)	1.312 (33.3)	.375 (9.5)	.625 (15.9)	

AS85049/3 Style 1 Environmental Backshells



Environmental Backshells

Glenair Connector Designator C
MIL-C-22992 Classes C, J, and R

TABLE II

Dash No.	Shell Size	Cable Range	
		Min	Max
1	12	.281 (7.1)	.375 (9.5)
2	12	.188 (4.8)	.281 (7.1)
3	14	.344 (8.7)	.438 (11.1)
4	16	.511 (13.0)	.605 (15.4)
5	16	.436 (11.1)	.530 (13.5)
6	16	.311 (7.9)	.405 (10.3)
7	18	.531 (13.5)	.625 (15.9)
8	18	.605 (15.4)	.699 (17.8)
9	18	.406 (10.3)	.500 (12.7)
10	18	.361 (9.2)	.455 (11.6)
11	20	.715 (18.2)	.828 (21.0)
12	20	.449 (11.4)	.562 (14.3)
13	22	.637 (16.2)	.750 (19.1)
14	22	.787 (20.0)	.900 (22.9)
15	22	.692 (17.6)	.805 (20.4)
16	24	.930 (23.6)	1.055 (26.8)
17	24	.675 (17.1)	1.000 (25.4)
18	24	.984 (25.0)	1.109 (28.2)
19	24	.755 (19.2)	.880 (22.4)
20	28	1.055 (26.8)	1.180 (30.0)
21	28	1.105 (28.1)	1.230 (31.2)
22	28	1.185 (30.1)	1.310 (33.3)
23	32	1.320 (33.5)	1.455 (37.0)
24	32	1.406 (35.7)	1.531 (38.9)
25	32	1.250 (31.8)	1.375 (34.9)
26	36	1.531 (38.9)	1.656 (42.1)
27	36	1.437 (36.5)	1.562 (39.7)
28	44	2.105 (53.5)	2.250 (57.2)
29	44	2.025 (51.4)	2.170 (55.1)

M85049/3 W 10 A 1
 Basic Part No. _____
 Body and Cap Finish _____
 A = Anodize
 W = 1,000 Hour Cadmium Olive Drab Over Electroless Nickel
 Style 1
 Type (A or B)
 Dash Number (Table II)

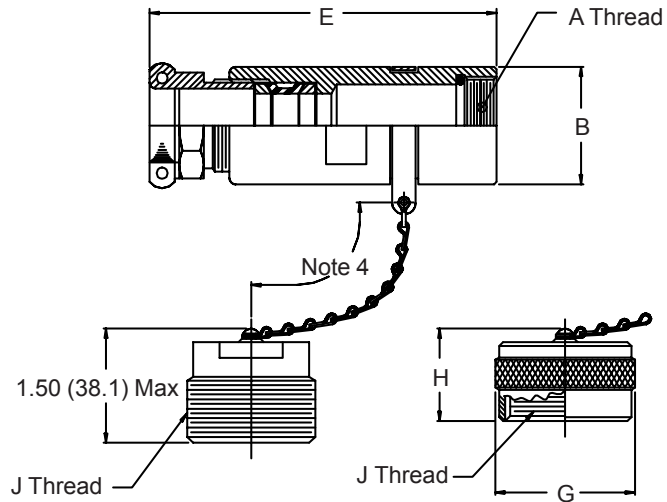

TYPE A - Plug Cap For use with MS17344
TYPE B - Receptacle Cap For use with MS17343, MS17345, and MS17347

- For complete dimensions see applicable Military Specification.
- Cable range is defined as the accommodations range for the wire bundle or cable. Dimensions shown are not intended for inspection criteria.
- Approx. Chain Lengths: Dash No. 01-12 = 5.0 (127.0); Dash No. 13-29 = 6.0 (152.4)

TABLE I

Shell Size	A Thread Class 2B-LH	B Dia ±.015 (.4)	E Max	G Dia Max	H Max	J Thread (plated) Class 2 (A or B)
12	.7500 - 20 UNEF	.933 (23.7)	3.365 (85.5)	1.094 (27.8)	.765 (19.4)	0.875-0.1P-0.2L-DS
14	.8750 - 20 UNEF	1.057 (26.8)	3.678 (93.4)	1.219 (31.0)	.765 (19.4)	1.000-0.1P-0.2L-DS
16	1.0000 - 20 UNEF	1.183 (30.0)	4.177 (106.1)	1.344 (34.1)	.980 (24.9)	1.125-0.1P-0.2L-DS
18	1.1250 - 18 UNEF	1.307 (33.2)	4.489 (114.0)	1.469 (37.3)	.980 (24.9)	1.250-0.1P-0.2L-DS
20	1.2500 - 18 UNEF	1.433 (36.4)	4.615 (117.2)	1.562 (39.7)	.980 (24.9)	1.375-0.1P-0.2L-DS
22	1.3750 - 18 UNEF	1.557 (39.5)	4.647 (118.0)	1.688 (42.9)	.980 (24.9)	1.500-0.1P-0.2L-DS
24	1.6250 - 18 UNEF	1.807 (45.9)	4.896 (124.4)	1.938 (49.2)	.980 (24.9)	1.750-0.1P-0.2L-DS
28	1.8750 - 16 UN	2.057 (52.2)	4.959 (126.0)	2.219 (56.4)	.980 (24.9)	2.000-0.1P-0.2L-DS
32	2.0625 - 16 UNS	2.307 (58.6)	5.021 (127.5)	2.469 (62.7)	.980 (24.9)	2.250-0.1P-0.2L-DS
36	2.3125 - 16 UNS	2.557 (64.9)	5.083 (129.1)	2.719 (69.1)	.980 (24.9)	2.500-0.1P-0.2L-DS
44	2.8750 - 16 UN	3.120 (79.2)	6.471 (164.4)	3.217 (81.7)	.980 (24.9)	3.000-0.1P-0.2L-DS

AS85049/3 Style 2 Environmental Backshells

**Glenair Connector
Designator C**

**MIL-C-22992 Classes
C, J, and R**

1. For complete dimensions see applicable Military Specification.
2. Metric dimensions (mm) are indicated in parentheses.
3. Cable range is defined as the accommodations range for the wire bundle or cable. Dimensions shown are not intended for inspection criteria.
4. Approx. Chain Lengths:
Dash No. 1-5 = 5.0 (127.0)
Dash No. 6-12 = 6.0 (152.4)

M85049/3 W 10 A 2

Basic Part No. _____

Body and Cap Finish _____
A = Anodize
W = 1,000 Hour Cadmium Olive Drab Over Electroless Nickel

Style 2
Type (A or B)
Dash Number (Table II)

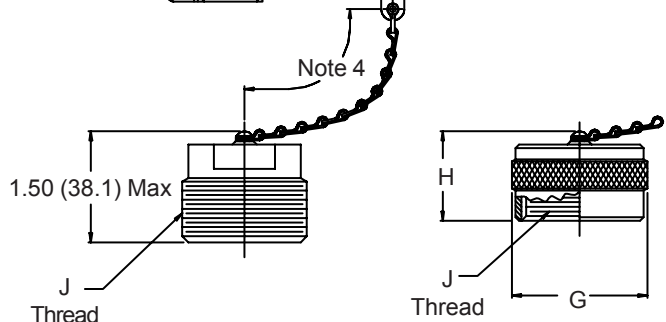
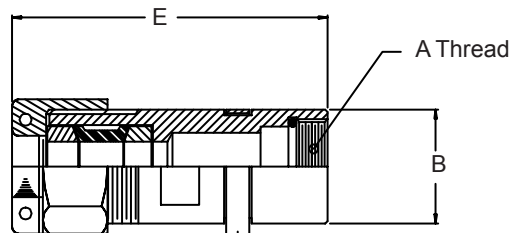

TYPE A - Plug Cap
For use with MS17344

TYPE B - Receptacle Cap
For use with MS17343,
MS17345, and MS17347

TABLE II

Dash No.	Shell Size	Cable Range	
		Min	Max
1	12	.246 (6.2)	.396 (10.1)
2	14	.321 (8.2)	.521 (13.2)
3	16	.446 (11.3)	.646 (16.4)
4	18	.565 (14.4)	.765 (19.4)
5	20	.690 (17.5)	.890 (22.6)
6	22	.815 (20.7)	1.015 (25.8)
7	24	.980 (24.9)	1.180 (30.0)
8	28	1.230 (31.2)	1.430 (36.3)
9	28	1.030 (26.2)	1.230 (31.2)
10	32	1.430 (36.3)	1.670 (42.4)
11	36	1.660 (42.2)	1.860 (47.2)
12	40	1.860 (47.2)	2.110 (53.6)

TABLE I

Shell Size	A Thread Class 2B-LH	B Dia ±.015 (.4)	E Max	G Dia Max	H Max	J Thread (plated) Class 2 (A or B)
12	.7500 - 20 UNEF	.933 (23.7)	4.000 (101.6)	1.094 (27.8)	.765 (19.4)	0.875-0.1P-0.2L-DS
14	.8750 - 20 UNEF	1.057 (26.8)	4.100 (104.1)	1.219 (31.0)	.765 (19.4)	1.000-0.1P-0.2L-DS
16	1.0000 - 20 UNEF	1.183 (30.0)	4.400 (111.8)	1.344 (34.1)	.980 (24.9)	1.125-0.1P-0.2L-DS
18	1.1250 - 18 UNEF	1.307 (33.2)	4.900 (124.5)	1.469 (37.3)	.980 (24.9)	1.250-0.1P-0.2L-DS
20	1.2500 - 18 UNEF	1.433 (36.4)	4.900 (124.5)	1.562 (39.7)	.980 (24.9)	1.375-0.1P-0.2L-DS
22	1.3750 - 18 UNEF	1.557 (39.5)	4.900 (124.5)	1.688 (42.9)	.980 (24.9)	1.500-0.1P-0.2L-DS
24	1.6250 - 18 UNEF	1.807 (45.9)	5.000 (127.0)	1.938 (49.2)	.980 (24.9)	1.750-0.1P-0.2L-DS
28	1.8750 - 16 UN	2.057 (52.2)	5.300 (134.6)	2.219 (56.4)	.980 (24.9)	2.000-0.1P-0.2L-DS
32	2.0625 - 16 UNS	2.307 (58.6)	5.600 (142.2)	2.469 (62.7)	.980 (24.9)	2.250-0.1P-0.2L-DS
36	2.3125 - 16 UNS	2.557 (64.9)	5.600 (142.2)	2.719 (69.1)	.980 (24.9)	2.500-0.1P-0.2L-DS
40	2.6250 - 16 UN	2.870 (72.9)	5.725 (145.4)	2.969 (75.4)	.980 (24.9)	2.750-0.1P-0.2L-DS

AS85049/3 Style 3 Environmental Backshells



Environmental Backshells

M85049/3 W 10 A 3

Glenair Connector Designator C
MIL-C-22992 Classes C, J, and R

Basic Part No. _____
 Body and Cap Finish _____
 A = Anodize
 W = 1,000 Hour Cadmium Olive Drab
 Over Electroless Nickel
 Style 3
 Type (A or B)
 Dash Number (Table II)

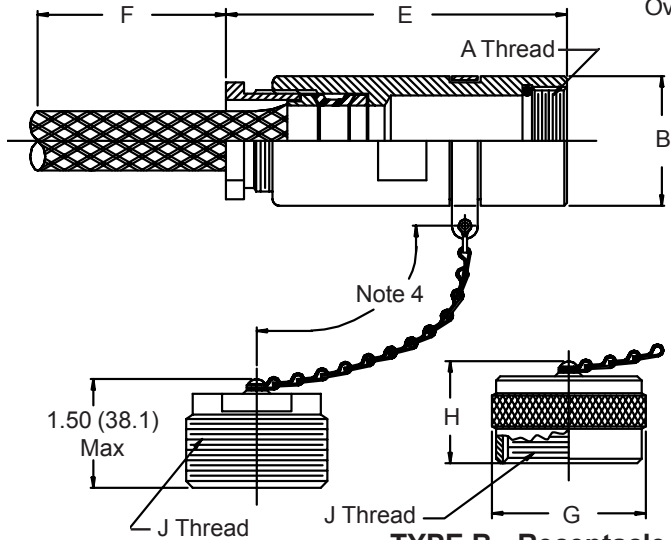

TYPE A - Plug Cap
For use with MS17344

TYPE B - Receptacle Cap - For use with MS17343, MS17345, and MS17347

- For complete dimensions see applicable Military Specification.
- Cable range is defined as the accommodations range for the wire bundle or cable. Dimensions shown are not intended for inspection criteria.
- Approx. Chain Lengths: Dash No. 1-11 = 5.0 (127.0); Dash No. 12-26 = 6.0 (152.4)

TABLE II

Dash No.	Shell Size	Cable Range		F Appr. Free Length
		Min	Max	
1	12	.281 (7.1)	.377 (9.6)	3.344 (84.9)
2	12	.219 (5.6)	.281 (7.1)	3.344 (84.9)
3	14	.400 (10.2)	.438 (11.1)	4.344 (110.3)
4	16	.511 (13.0)	.605 (15.4)	5.188 (131.8)
5	16	.436 (11.1)	.530 (13.5)	4.688 (119.1)
6	16	.316 (8.0)	.405 (10.3)	3.688 (93.7)
7	18	.605 (15.4)	.699 (17.8)	6.188 (157.2)
8	18	.560 (14.2)	.625 (15.9)	6.188 (157.2)
9	18	.361 (9.2)	.455 (11.6)	4.188 (106.4)
10	20	.715 (18.2)	.828 (21.0)	6.688 (169.9)
11	20	.449 (11.4)	.562 (14.3)	5.188 (131.8)
12	22	.787 (20.0)	.900 (22.9)	7.188 (182.6)
13	22	.637 (16.2)	.750 (19.1)	6.688 (169.9)
14	24	.984 (25.0)	1.109 (28.2)	7.688 (195.3)
15	24	.875 (22.2)	1.000 (25.4)	7.188 (182.6)
16	24	.755 (19.2)	.880 (22.4)	6.688 (169.9)
17	28	1.185 (30.1)	1.310 (33.3)	8.688 (220.7)
18	28	1.105 (28.1)	1.230 (31.2)	8.188 (208.0)
19	28	1.055 (26.8)	1.180 (30.0)	8.188 (208.0)
20	32	1.406 (35.7)	1.531 (38.9)	10.688 (271.5)
21	32	1.320 (33.5)	1.455 (37.0)	9.688 (246.1)
22	32	1.250 (31.8)	1.375 (34.9)	9.688 (246.1)
23	36	1.531 (38.9)	1.656 (42.1)	12.688 (322.3)
24	36	1.437 (36.5)	1.562 (39.7)	11.188 (284.2)
25	44	2.105 (53.5)	2.250 (57.2)	17.188 (436.6)
26	44	2.025 (51.4)	2.170 (55.1)	17.188 (436.6)

TABLE I

Shell Size	A Thread Class 2B-LH	B Dia ±.015 (.4)	E Max	G Dia Max	H Max	J Thread (plated) Class 2 (A or B)
12	.7500 - 20 UNEF	.933 (23.7)	2.935 (74.5)	1.094 (27.8)	.765 (19.4)	0.875-0.1P-0.2L-DS
14	.8750 - 20 UNEF	1.057 (26.8)	3.248 (82.5)	1.219 (31.0)	.765 (19.4)	1.000-0.1P-0.2L-DS
16	1.0000 - 20 UNEF	1.183 (30.0)	3.712 (94.3)	1.344 (34.1)	.980 (24.9)	1.125-0.1P-0.2L-DS
18	1.1250 - 18 UNEF	1.307 (33.2)	4.024 (102.2)	1.469 (37.3)	.980 (24.9)	1.250-0.1P-0.2L-DS
20	1.2500 - 18 UNEF	1.433 (36.4)	4.115 (104.5)	1.562 (39.7)	.980 (24.9)	1.375-0.1P-0.2L-DS
22	1.3750 - 18 UNEF	1.557 (39.5)	4.150 (105.4)	1.688 (42.9)	.980 (24.9)	1.500-0.1P-0.2L-DS
24	1.6250 - 18 UNEF	1.807 (45.9)	4.212 (107.0)	1.938 (49.2)	.980 (24.9)	1.750-0.1P-0.2L-DS
28	1.8750 - 16 UN	2.057 (52.2)	4.275 (108.6)	2.219 (56.4)	.980 (24.9)	2.000-0.1P-0.2L-DS
32	2.0625 - 16 UNS	2.307 (58.6)	4.337 (110.2)	2.469 (62.7)	.980 (24.9)	2.250-0.1P-0.2L-DS
36	2.3125 - 16 UNS	2.557 (64.9)	4.399 (111.7)	2.719 (69.1)	.980 (24.9)	2.500-0.1P-0.2L-DS
44	2.8750 - 16 UN	3.120 (79.2)	5.799 (147.3)	3.217 (81.7)	.980 (24.9)	3.000-0.1P-0.2L-DS

© 2005 Glenair, Inc.

CAGE Code 06324

Printed in U.S.A.

AS85049/4 Style 1 Environmental Backshells

Glenair Connector Designator C

**MIL-C-22992
Classes C, J, and R**

M85049/4 W 10 A 1

Basic Part No. _____
 Body and Cap Finish _____
 A = Anodize
 W = 1,000 Hour Cadmium Olive Drab Over Electroless Nickel

Style 1
 Type (A or B)
 Dash Number (Table II)

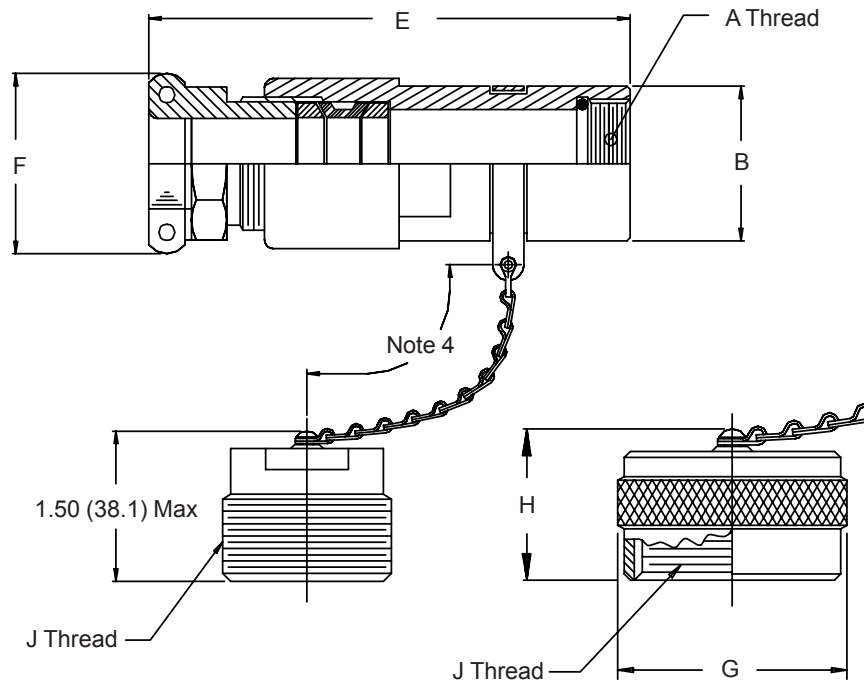

TYPE A - Plug Cap
For use with MS17344

TYPE B - Receptacle Cap
For use with MS17343,
MS17345, and MS17347

TABLE I

Shell Size	A Thread Class 2B-LH	B Dia ±.015 (.4)	G Dia Max	H Max	J Thread (plated) Class 2 (A or B)
12	.7500 - 20 UNEF	.933 (23.7)	1.094 (27.8)	.765 (19.4)	0.875-0.1P-0.2L-DS
14	.8750 - 20 UNEF	1.057 (26.8)	1.219 (31.0)	.765 (19.4)	1.000-0.1P-0.2L-DS
18	1.1250 - 18 UNEF	1.307 (33.2)	1.469 (37.3)	.980 (24.9)	1.250-0.1P-0.2L-DS
20	1.2500 - 18 UNEF	1.433 (36.4)	1.562 (39.7)	.980 (24.9)	1.375-0.1P-0.2L-DS
22	1.3750 - 18 UNEF	1.557 (39.5)	1.688 (42.9)	.980 (24.9)	1.500-0.1P-0.2L-DS
24	1.6250 - 18 UNEF	1.807 (45.9)	1.938 (49.2)	.980 (24.9)	1.750-0.1P-0.2L-DS
28	1.8750 - 16 UN	2.057 (52.2)	2.219 (56.4)	.980 (24.9)	2.000-0.1P-0.2L-DS
32	2.0625 - 16 UNS	2.307 (58.6)	2.469 (62.7)	.980 (24.9)	2.250-0.1P-0.2L-DS
36	2.3125 - 16 UNS	2.557 (64.9)	2.719 (69.1)	.980 (24.9)	2.500-0.1P-0.2L-DS
40	2.6250 - 16 UN	2.870 (72.9)	2.969 (75.4)	.980 (24.9)	2.750-0.1P-0.2L-DS
44	2.8750 - 16 UN	3.120 (79.2)	3.217 (81.7)	.980 (24.9)	3.000-0.1P-0.2L-DS

AS85049/4 Style 1
Environmental Backshells



Environmental
Backshells

TABLE II

Dash No.	Shell Size	E		F		Cable Range	
		Max	(mm)	±.031	(.8)	Min	Max
1	12	4.275	(108.6)	1.375	(34.9)	.436	(11.1) .530 (13.5)
2	12	3.678	(93.4)	1.125	(28.6)	.406	(10.3) .500 (12.7)
3	12	4.275	(108.6)	1.375	(34.9)	.311	(7.9) .405 (10.3)
4	14	4.177	(106.1)	1.375	(34.9)	.511	(13.0) .605 (15.4)
5	14	4.489	(114.0)	1.562	(39.7)	.531	(13.5) .625 (15.9)
6	14	4.177	(106.1)	1.375	(34.9)	.436	(11.1) .530 (13.5)
7	14	4.177	(106.1)	1.375	(34.9)	.311	(7.9) .405 (10.3)
8	18	4.584	(116.4)	1.688	(42.9)	.715	(18.2) .828 (21.0)
9	20	4.647	(118.0)	1.812	(46.0)	.637	(16.2) .750 (19.1)
10	20	4.896	(124.4)	2.125	(54.0)	.875	(22.2) 1.000 (25.4)
11	20	4.647	(118.0)	1.812	(46.0)	.787	(20.0) .900 (22.9)
12	20	4.896	(124.4)	2.125	(54.0)	.930	(23.6) 1.055 (26.8)
13	22	4.896	(124.4)	2.125	(54.0)	.875	(22.2) 1.000 (25.4)
14	22	4.896	(124.4)	2.125	(54.0)	.984	(25.0) 1.109 (28.2)
15	24	4.959	(126.0)	2.469	(62.7)	1.055	(26.8) 1.180 (30.0)
16	24	4.959	(126.0)	2.469	(62.7)	1.185	(30.1) 1.310 (33.3)
17	24	4.959	(126.0)	2.469	(62.7)	1.105	(28.1) 1.230 (31.2)
18	24	4.959	(126.0)	2.625	(66.7)	1.250	(31.8) 1.375 (34.9)
19	28	5.021	(127.5)	2.625	(66.7)	1.320	(33.5) 1.445 (36.7)
20	28	5.021	(127.5)	2.625	(66.7)	1.406	(35.7) 1.531 (38.9)
21	28	5.021	(127.5)	2.625	(66.7)	1.250	(31.8) 1.375 (34.9)
22	32	5.083	(129.1)	2.953	(75.0)	1.531	(38.9) 1.656 (42.1)
23	32	5.385	(136.8)	3.171	(80.5)	1.700	(43.2) 1.828 (46.4)
24	32	5.083	(129.1)	2.953	(75.0)	1.437	(36.5) 1.562 (39.7)
25	32	5.385	(136.8)	3.171	(80.5)	1.605	(40.8) 1.730 (43.9)
26	36	5.354	(136.0)	3.171	(80.5)	1.775	(45.1) 1.900 (48.3)
27	36	5.354	(136.0)	3.171	(80.5)	1.605	(40.8) 1.730 (43.9)
28	36	5.354	(136.0)	3.171	(80.5)	1.700	(43.2) 1.825 (46.4)
29	36	5.354	(136.0)	3.171	(80.5)	1.859	(47.2) 1.984 (50.4)
30	36	5.385	(136.8)	3.375	(85.7)	1.917	(48.7) 2.062 (52.4)
31	40	5.682	(144.3)	3.625	(92.1)	2.230	(56.6) 2.375 (60.3)
32	40	5.682	(144.3)	3.500	(88.9)	2.105	(53.5) 2.250 (57.2)
33	40	5.620	(142.7)	3.375	(85.7)	2.000	(50.8) 2.145 (54.5)
34	40	5.620	(142.7)	3.375	(85.7)	1.917	(48.7) 2.062 (52.4)
35	44	6.471	(164.4)	3.531	(89.7)	2.183	(55.4) 2.328 (59.1)

1. For complete dimensions see applicable Military Specification.
2. Metric dimensions (mm) are indicated in parentheses.
3. Cable range is defined as the accommodations range for the wire bundle or cable. Dimensions shown are not intended for inspection criteria.
4. Approx. Chain Lengths:
 Dash No. 1-12 = 5.0 (127.0);
 Dash No. 13-35 = 6.0 (152.4)

**Glenair Connector
Designator C**

**MIL-C-22992 Classes
C, J, and R**

M85049/4 W 10 A 2

Basic Part No. _____
 Body and Cap Finish _____
 A = Anodize
 W = 1,000 Hour Cadmium Olive Drab
 Over Electroless Nickel _____
 Style 2 _____
 Type (A or B) _____
 Dash Number (Table II) _____

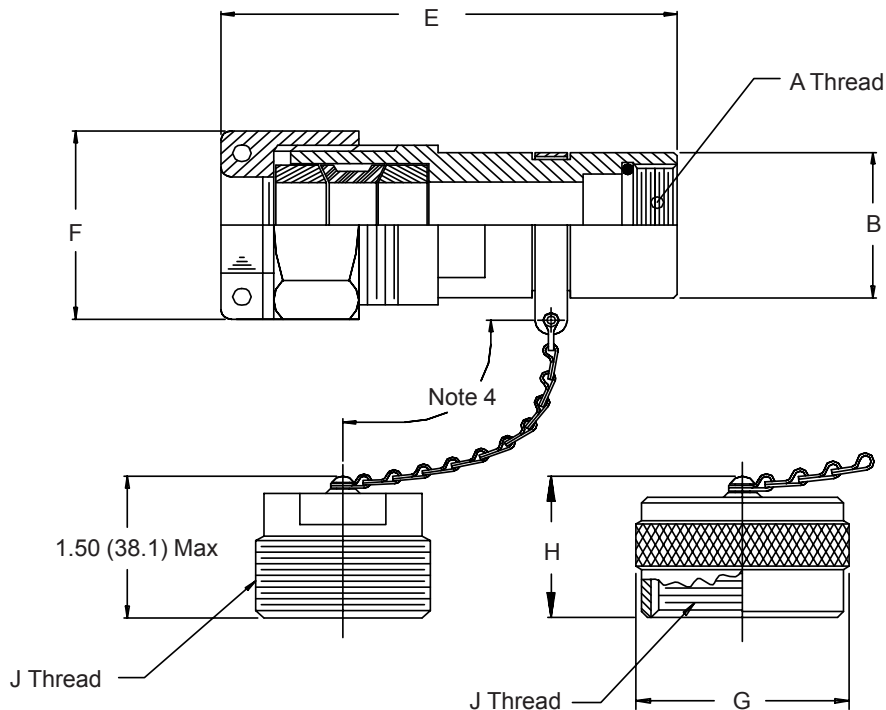

**TYPE A - Plug Cap
For use with MS17344**

**TYPE B - Receptacle Cap
For use with MS17343,
MS17345, and MS17347**

1. For complete dimensions see applicable Military Specification.
2. Metric dimensions (mm) are indicated in parentheses.
3. Cable range is defined as the accommodations range for the wire bundle or cable. Dimensions shown are not intended for inspection criteria.
4. Approx. Chain Lengths:
 Dash No. 1-5 = 5.0 (127.0)
 Dash No. 6-13 = 6.0 (152.4)

AS85049/4 Style 2
Environmental Backshells



Environmental
Backshells

TABLE I

Shell Size	A Thread Class 2B-LH	B Dia ±.015 (.4)	E Max	G Dia Max	H Max	J Thread (plated) Class 2 (A or B)
12	.7500 - 20 UNEF	.933 (23.7)	4.000 (101.6)	1.094 (27.8)	.765 (19.4)	0.875-0.1P-0.2L-DS
14	.8750 - 20 UNEF	1.057 (26.8)	4.100 (104.1)	1.219 (31.0)	.765 (19.4)	1.000-0.1P-0.2L-DS
16	1.0000 - 20 UNEF	1.183 (30.0)	4.800 (121.9)	1.344 (34.1)	.980 (24.9)	1.125-0.1P-0.2L-DS
18	1.1250 - 18 UNEF	1.307 (33.2)	4.900 (124.5)	1.469 (37.3)	.980 (24.9)	1.250-0.1P-0.2L-DS
20	1.2500 - 18 UNEF	1.433 (36.4)	4.900 (124.5)	1.562 (39.7)	.980 (24.9)	1.375-0.1P-0.2L-DS
22	1.3750 - 18 UNEF	1.557 (39.5)	4.900 (124.5)	1.688 (42.9)	.980 (24.9)	1.500-0.1P-0.2L-DS
24	1.6250 - 18 UNEF	1.807 (45.9)	5.000 (127.0)	1.938 (49.2)	.980 (24.9)	1.750-0.1P-0.2L-DS
28	1.8750 - 16 UN	2.057 (52.2)	5.300 (134.6)	2.219 (56.4)	.980 (24.9)	2.000-0.1P-0.2L-DS
32	2.0625 - 16 UNS	2.307 (58.6)	5.600 (142.2)	2.469 (62.7)	.980 (24.9)	2.250-0.1P-0.2L-DS
36	2.3125 - 16 UNS	2.557 (64.9)	5.725 (145.4)	2.719 (69.1)	.980 (24.9)	2.500-0.1P-0.2L-DS
40	2.6250 - 16 UN	2.870 (72.9)	5.725 (145.4)	2.969 (75.4)	.980 (24.9)	2.750-0.1P-0.2L-DS

TABLE II

Dash No.	Shell Size	F ±.005 (.1)	Cable Range	
			Min	Max
1	12	1.219 (31.0)	.321 (8.2)	.521 (13.2)
2	14	1.344 (34.1)	.446 (11.3)	.646 (16.4)
3	16	1.469 (37.3)	.565 (14.4)	.765 (19.4)
4	18	1.625 (41.3)	.690 (17.5)	.890 (22.6)
5	20	1.750 (44.5)	.815 (20.7)	1.015 (25.8)
6	22	2.000 (50.8)	.980 (24.9)	1.180 (30.0)
7	24	2.250 (57.2)	1.230 (31.2)	1.430 (36.3)
8	24	2.250 (57.2)	1.030 (26.2)	1.230 (31.2)
9	28	2.500 (63.5)	1.430 (36.3)	1.670 (42.4)
10	32	2.750 (69.9)	1.660 (42.2)	1.860 (47.2)
11	36	3.062 (77.8)	1.860 (47.2)	2.110 (53.6)
12	40	3.437 (87.3)	2.200 (55.9)	2.400 (61.0)
13	40	3.437 (87.3)	2.200 (55.9)	2.200 (55.9)

Glenair Connector Designator C
MIL-C-22992 Classes C, J, and R

M85049/4 W 10 A 3

Basic Part No. _____
 Body and Cap Finish _____
 A = Anodize
 W = 1,000 Hour Cadmium Olive Drab
 Over Electroless Nickel _____
 Style 3
 Type (A or B)
 Dash Number (Table II)

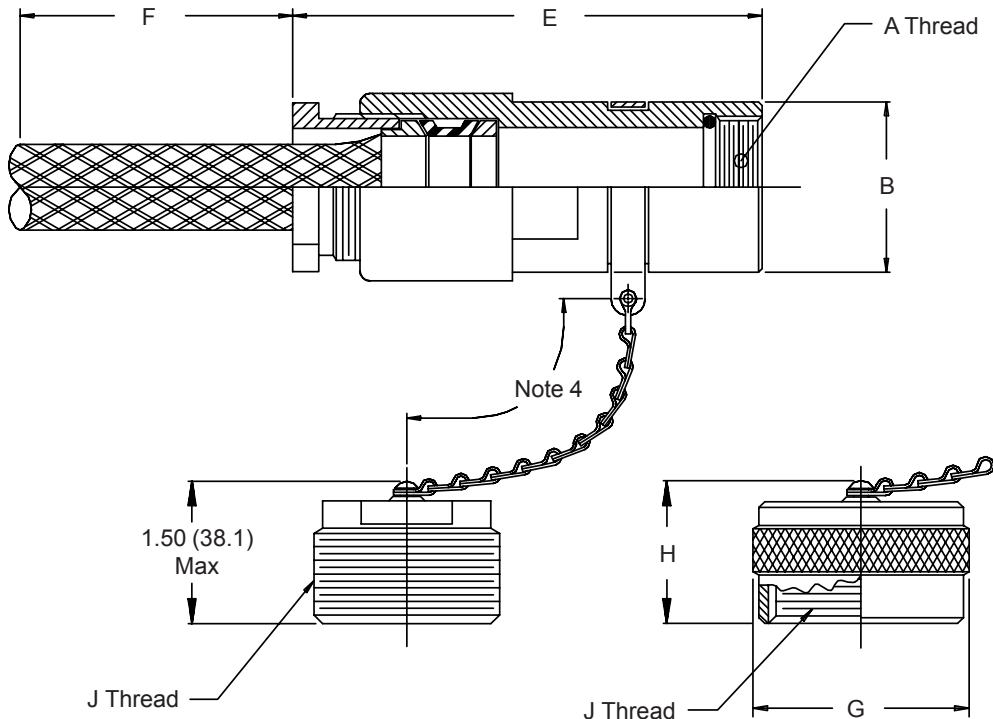

TYPE A - Plug Cap
For use with MS17344

TYPE B - Receptacle Cap
For use with MS17343,
MS17345, and MS17347

1. For complete dimensions see applicable Military Specification.
2. Metric dimensions (mm) are indicated in parentheses.
3. Cable range is defined as the accommodations range for the wire bundle or cable. Dimensions shown are not intended for inspection criteria.
4. Approx. Chain Lengths:
 Dash No. 1-12 = 5.0 (127.0)
 Dash No. 13-33 = 6.0 (152.4)

**AS85049/4 Style 3
Environmental Backshells**



Environmental
Backshells

TABLE I

Shell Size	A Thread Class 2B-LH	B Dia ±.015 (.4)	G Dia Max	H Max	J Thread (plated) Class 2 (A or B)
12	.7500 - 20 UNEF	.933 (23.7)	1.094 (27.8)	.765 (19.4)	0.875-0.1P-0.2L-DS
14	.8750 - 20 UNEF	1.057 (26.8)	1.219 (31.0)	.765 (19.4)	1.000-0.1P-0.2L-DS
18	1.1250 - 18 UNEF	1.307 (33.2)	1.469 (37.3)	.980 (24.9)	1.250-0.1P-0.2L-DS
20	1.2500 - 18 UNEF	1.433 (36.4)	1.562 (39.7)	.980 (24.9)	1.375-0.1P-0.2L-DS
22	1.3750 - 18 UNEF	1.557 (39.5)	1.688 (42.9)	.980 (24.9)	1.500-0.1P-0.2L-DS
24	1.6250 - 18 UNEF	1.807 (45.9)	1.938 (49.2)	.980 (24.9)	1.750-0.1P-0.2L-DS
28	1.8750 - 16 UN	2.057 (52.2)	2.219 (56.4)	.980 (24.9)	2.000-0.1P-0.2L-DS
32	2.0625 - 16 UNS	2.307 (58.6)	2.469 (62.7)	.980 (24.9)	2.250-0.1P-0.2L-DS
36	2.3125 - 16 UNS	2.557 (64.9)	2.719 (69.1)	.980 (24.9)	2.500-0.1P-0.2L-DS
40	2.6250 - 16 UN	2.870 (72.9)	2.969 (75.4)	.980 (24.9)	3.000-0.1P-0.2L-DS

TABLE II

Dash No.	Shell Size	Cable Range		E Max	F Appr. Free Length
		Min	Max		
1	12	.436 (11.1)	.530 (13.5)	3.810 (96.8)	4.688 (119.1)
2	12	.406 (10.3)	.500 (12.7)	3.248 (82.5)	4.344 (110.3)
3	12	.316 (8.0)	.405 (10.3)	3.810 (96.8)	3.688 (93.7)
4	14	.560 (14.2)	.625 (15.9)	4.024 (102.2)	6.188 (157.2)
5	14	.511 (13.0)	.605 (15.4)	3.712 (94.3)	5.188 (131.8)
6	14	.430 (10.9)	.530 (13.5)	3.712 (94.3)	4.688 (119.1)
7	14	.316 (8.0)	.405 (10.3)	3.712 (94.3)	3.688 (93.7)
8	18	.715 (18.2)	.828 (21.0)	4.087 (103.8)	6.688 (169.9)
9	20	.930 (23.6)	1.055 (26.8)	4.212 (107.0)	7.688 (195.3)
10	20	.875 (22.2)	1.000 (25.4)	4.212 (107.0)	7.188 (182.6)
11	20	.787 (20.0)	.900 (22.9)	4.150 (105.4)	7.188 (182.6)
12	20	.637 (16.2)	.750 (19.1)	4.150 (105.4)	7.188 (182.6)
13	22	.984 (25.0)	1.109 (28.2)	4.212 (107.0)	7.688 (195.3)
14	22	.875 (22.2)	1.000 (25.4)	4.212 (107.0)	7.188 (182.6)
15	24	1.250 (31.8)	1.375 (34.9)	4.275 (108.6)	9.688 (246.1)
16	24	1.185 (30.1)	1.310 (33.3)	4.275 (108.6)	8.688 (220.7)
17	24	1.105 (28.1)	1.230 (31.2)	4.275 (108.6)	8.188 (208.0)
18	24	1.055 (26.8)	1.180 (30.0)	4.275 (108.6)	8.188 (208.0)
19	28	1.406 (35.7)	1.531 (38.9)	4.337 (110.2)	10.688 (271.5)
20	28	1.320 (33.5)	1.445 (36.7)	4.337 (110.2)	9.688 (246.1)
21	28	1.250 (31.8)	1.375 (34.9)	4.337 (110.2)	9.688 (246.1)
22	32	1.700 (43.2)	1.825 (46.4)	4.704 (119.5)	13.688 (347.7)
23	32	1.605 (40.8)	1.730 (43.9)	4.704 (119.5)	13.688 (347.7)
24	32	1.531 (38.9)	1.656 (42.1)	4.399 (111.7)	12.688 (322.3)
25	36	1.917 (48.7)	2.062 (52.4)	4.704 (119.5)	14.188 (360.4)
26	36	1.859 (47.2)	1.984 (50.4)	4.673 (118.7)	13.688 (347.7)
27	36	1.775 (45.1)	1.900 (48.3)	4.673 (118.7)	13.688 (347.7)
28	36	1.700 (43.2)	1.825 (46.4)	4.673 (118.7)	13.688 (347.7)
29	36	1.605 (40.8)	1.730 (43.9)	4.673 (118.7)	13.688 (347.7)
30	40	2.230 (56.6)	2.375 (60.3)	5.000 (127.0)	18.188 (462.0)
31	40	2.105 (53.5)	2.250 (57.2)	5.000 (127.0)	17.188 (436.6)
32	40	2.000 (50.8)	2.145 (54.5)	4.939 (125.5)	14.188 (360.4)
33	40	1.917 (48.7)	2.062 (52.4)	4.939 (125.5)	14.188 (360.4)

AS85049/5 Style 1 Environmental Backshells

Glenair Connector Designator C
MIL-C-22992 Classes C, J, and R

M85049/5 W 10 A 1

Basic Part No. _____
 Body and Cap Finish _____
 A = Anodize
 W = 1,000 Hour Cadmium Olive Drab
 Over Electroless Nickel

Style 1
 Type (A or B)
 Dash Number (Table II)

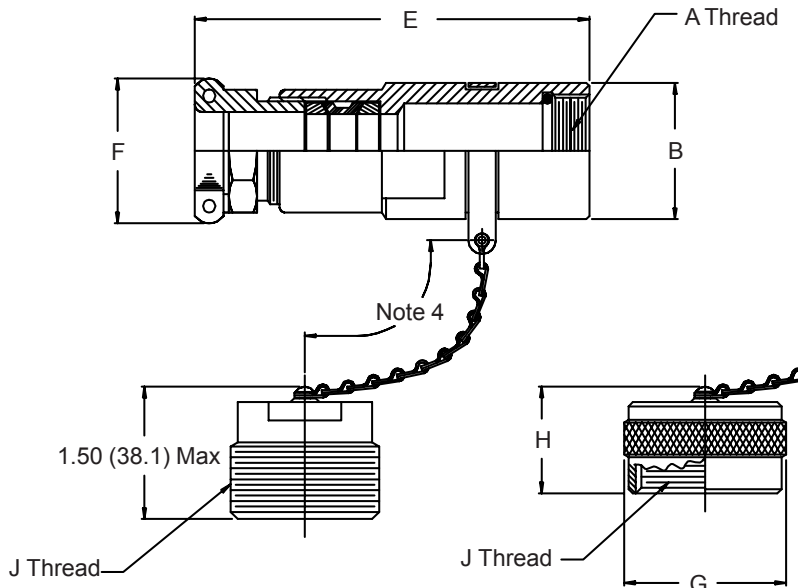

TYPE A - Plug Cap
For use with MS17344

TYPE B - Receptacle Cap
For use with MS17343,
MS17345, and MS17347

TABLE I

Shell Size	A Thread Class 2B-LH	B Dia ±.015 (.4)	G Dia Max	H Max	J Thread (plated) Class 2 (A or B)
12	.7500 - 20 UNEF	.933 (23.7)	1.094 (27.8)	.765 (19.4)	0.875-0.1P-0.2L-DS
18	1.1250 - 18 UNEF	1.307 (33.2)	1.469 (37.3)	.980 (24.9)	1.250-0.1P-0.2L-DS
20	1.2500 - 18 UNEF	1.433 (36.4)	1.562 (39.7)	.980 (24.9)	1.375-0.1P-0.2L-DS
22	1.3750 - 18 UNEF	1.557 (39.5)	1.688 (42.9)	.980 (24.9)	1.500-0.1P-0.2L-DS
24	1.6250 - 18 UNEF	1.807 (45.9)	1.938 (49.2)	.980 (24.9)	1.750-0.1P-0.2L-DS
28	1.8750 - 16 UN	2.057 (52.2)	2.219 (56.4)	.980 (24.9)	2.000-0.1P-0.2L-DS
32	2.0625 - 16 UNS	2.307 (58.6)	2.469 (62.7)	.980 (24.9)	2.250-0.1P-0.2L-DS
36	2.3125 - 16 UNS	2.557 (64.9)	2.719 (69.1)	.980 (24.9)	2.500-0.1P-0.2L-DS
40	2.6250 - 16 UN	2.870 (72.9)	2.969 (75.4)	.980 (24.9)	2.750-0.1P-0.2L-DS

1. For complete dimensions see applicable Military Specification.
2. Metric dimensions (mm) are indicated in parentheses.
3. Cable range is defined as the accommodations range for the wire bundle or cable. Dimensions shown are not intended for inspection criteria.
4. Approx. Chain Lengths: Dash No. 1-9 = 5.0 (127.0); Dash No. 10-46 = 6.0 (152.4)

AS85049/5 Style 1
Environmental Backshells



Environmental
Backshells

TABLE II

Dash No.	Shell Size	E		F		Cable Range			
		Max	()	±.031	(.8)	Min	Max		
1	12	3.182	(80.8)	.938	(23.8)	.156	(4.0)	.250	(6.4)
2	18	3.901	(99.1)	1.062	(27.0)	.281	(7.1)	.375	(9.5)
3	18	3.932	(99.9)	1.125	(28.6)	.281	(7.1)	.375	(9.5)
4	18	3.901	(99.1)	1.062	(27.0)	.188	(4.8)	.281	(7.1)
5	18	4.177	(106.1)	1.375	(34.9)	.511	(13.0)	.605	(15.4)
6	18	4.177	(106.1)	1.375	(34.9)	.436	(11.1)	.530	(13.5)
7	20	4.489	(114.0)	1.562	(39.7)	.605	(15.4)	.699	(17.8)
8	20	4.489	(114.0)	1.562	(39.7)	.361	(9.2)	.455	(11.6)
9	20	4.306	(109.4)	1.375	(34.9)	.511	(13.0)	.605	(15.4)
10	22	4.584	(116.4)	1.688	(42.9)	.449	(11.4)	.562	(14.3)
11	22	4.306	(109.4)	1.375	(34.9)	.311	(7.9)	.405	(10.3)
12	22	4.584	(116.4)	1.688	(42.9)	.715	(18.2)	.828	(21.0)
13	24	4.647	(118.0)	1.812	(46.0)	.787	(20.0)	.900	(22.9)
14	24	4.647	(118.0)	1.812	(46.0)	.517	(13.1)	.630	(16.0)
15	24	4.647	(118.0)	1.812	(46.0)	.637	(16.2)	.750	(19.1)
16	24	4.647	(118.0)	1.812	(46.0)	.857	(21.8)	.970	(24.6)
17	24	4.542	(115.4)	1.688	(42.9)	.715	(18.2)	.828	(21.0)
18	24	4.647	(118.0)	1.812	(46.0)	.692	(17.6)	.805	(20.4)
19	28	4.896	(124.4)	2.125	(54.0)	.755	(19.2)	.880	(22.4)
20	28	4.896	(124.4)	2.125	(54.0)	.984	(25.0)	1.109	(28.2)
21	28	4.647	(118.0)	1.812	(46.0)	.637	(16.2)	.750	(19.1)
22	28	4.229	(107.4)	1.125	(28.6)	.281	(7.1)	.375	(9.5)
23	28	4.647	(118.0)	1.812	(46.0)	.857	(21.8)	.970	(24.6)
24	28	4.896	(124.4)	2.125	(54.0)	.875	(22.2)	1.000	(25.4)
25	28	4.431	(112.5)	1.375	(34.9)	.436	(11.1)	.530	(13.5)
26	28	4.647	(118.0)	1.812	(46.0)	.567	(14.4)	.680	(17.3)
27	32	4.896	(124.4)	2.125	(54.0)	.930	(23.6)	1.055	(26.8)
28	32	4.959	(126.0)	2.469	(62.7)	1.105	(28.1)	1.230	(31.2)
29	32	4.647	(118.0)	1.812	(46.0)	.637	(16.2)	.750	(19.1)
30	32	4.896	(124.4)	2.125	(54.0)	.755	(19.2)	.880	(22.4)
31	32	4.896	(124.4)	2.125	(54.0)	.984	(25.0)	1.109	(28.2)
32	32	4.647	(118.0)	1.812	(46.0)	.857	(21.8)	.970	(24.6)
33	32	4.276	(108.6)	1.125	(28.6)	.281	(7.1)	.375	(9.5)
34	32	4.431	(112.5)	1.375	(34.9)	.436	(11.1)	.530	(13.5)
35	32	4.959	(126.0)	2.469	(62.7)	1.005	(25.5)	1.130	(28.7)
36	36	4.959	(126.0)	2.469	(62.7)	1.185	(30.1)	1.310	(33.3)
37	36	4.896	(124.4)	2.125	(54.0)	.984	(25.0)	1.109	(28.2)
38	36	5.021	(127.5)	2.625	(66.7)	1.250	(31.8)	1.375	(34.9)
39	36	4.959	(126.0)	2.469	(62.7)	1.055	(26.8)	1.180	(30.0)
40	36	5.021	(127.5)	2.625	(66.7)	1.320	(33.5)	1.445	(36.7)
41	36	4.651	(118.1)	1.812	(46.0)	.857	(21.8)	.970	(24.6)
42	36	4.959	(126.0)	2.469	(62.7)	1.105	(28.1)	1.230	(31.2)
43	40	6.354	(161.4)	3.171	(80.5)	1.815	(46.1)	1.940	(49.3)
44	40	6.354	(161.4)	3.171	(80.5)	1.700	(43.2)	1.825	(46.4)
45	40	6.354	(161.4)	3.171	(80.5)	1.605	(40.8)	1.730	(43.9)
46	40	6.057	(153.8)	2.953	(75.0)	1.531	(38.9)	1.656	(42.1)

AS85049/5 Style 2 Environmental Backshells

Glenair Connector
Designator C

MIL-C-22992 Classes
C, J, and R

M85049/5 W 10 A 2

Basic Part No. _____
 Body and Cap Finish _____
 A = Anodize
 W = 1,000 Hour Cadmium Olive Drab
 Over Electroless Nickel _____
 Style 2 _____
 Type (A or B) _____
 Dash Number (Table II) _____

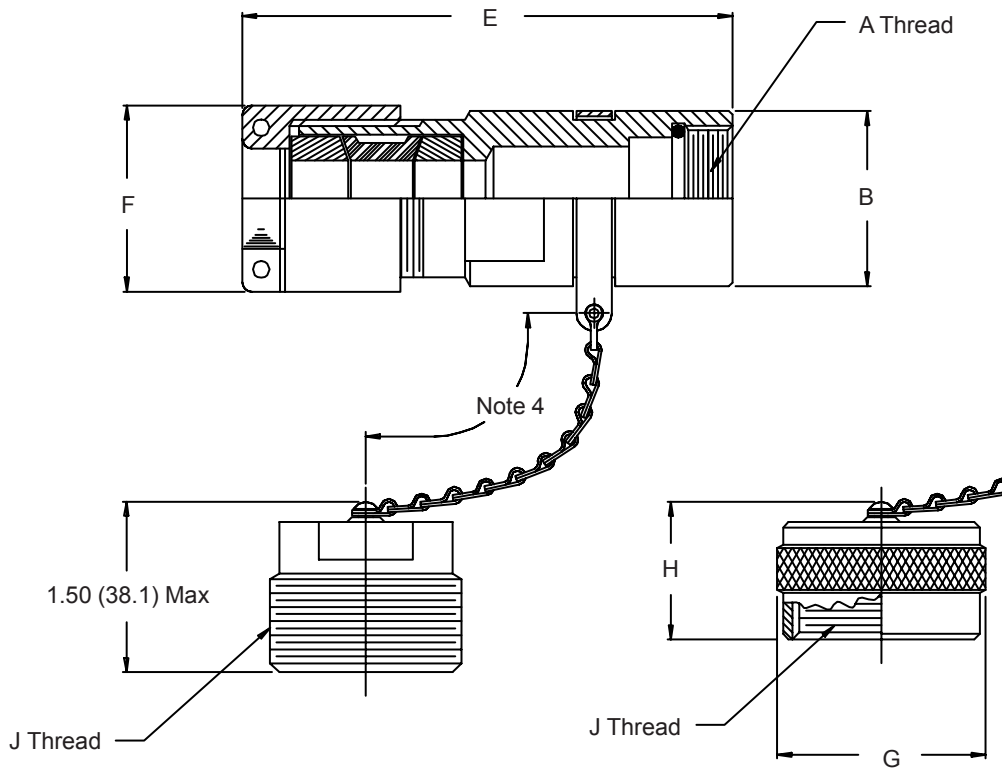

TYPE A - Plug Cap
For use with MS17344

TYPE B - Receptacle Cap
For use with MS17343,
MS17345, and MS17347

**AS85049/5 Style 2
Environmental Backshells**



Environmental
Backshells

TABLE I

Shell Size	A Thread Class 2B-LH	B Dia ±.015 (.4)	E Max	G Dia Max	H Max	J Thread (plated) Class 2 (A or B)
12	.7500 - 20 UNEF	.933 (23.7)	4.000 (101.6)	1.094 (27.8)	.765 (19.4)	0.875-0.1P-0.2L-DS
14	.8750 - 20 UNEF	1.057 (26.8)	4.100 (104.1)	1.219 (31.0)	.765 (19.4)	1.000-0.1P-0.2L-DS
16	1.0000 - 20 UNEF	1.183 (30.0)	4.400 (111.8)	1.344 (34.1)	.980 (24.9)	1.125-0.1P-0.2L-DS
18	1.1250 - 18 UNEF	1.307 (33.2)	4.600 (116.8)	1.469 (37.3)	.980 (24.9)	1.250-0.1P-0.2L-DS
20	1.2500 - 18 UNEF	1.433 (36.4)	4.900 (124.5)	1.562 (39.7)	.980 (24.9)	1.375-0.1P-0.2L-DS
22	1.3750 - 18 UNEF	1.557 (39.5)	4.900 (124.5)	1.688 (42.9)	.980 (24.9)	1.500-0.1P-0.2L-DS
24	1.6250 - 18 UNEF	1.807 (45.9)	5.000 (127.0)	1.938 (49.2)	.980 (24.9)	1.750-0.1P-0.2L-DS
28	1.8750 - 16 UN	2.057 (52.2)	5.300 (134.6)	2.219 (56.4)	.980 (24.9)	2.000-0.1P-0.2L-DS
32	2.0625 - 16 UNS	2.307 (58.6)	5.600 (142.2)	2.469 (62.7)	.980 (24.9)	2.250-0.1P-0.2L-DS
36	2.3125 - 16 UNS	2.557 (64.9)	5.600 (142.2)	2.719 (69.1)	.980 (24.9)	2.500-0.1P-0.2L-DS
40	2.6250 - 16 UN	2.870 (72.9)	5.725 (145.4)	2.969 (75.4)	.980 (24.9)	2.750-0.1P-0.2L-DS

TABLE II

Dash No.	Shell Size	F ±.005 (.1)	Cable Range	
			Min	Max
1	12	.969 (24.6)	.130 (3.3)	.280 (7.1)
2	14	1.094 (27.8)	.246 (6.2)	.396 (10.1)
3	16	1.219 (31.0)	.321 (8.2)	.521 (13.2)
4	18	1.344 (34.1)	.446 (11.3)	.646 (16.4)
5	18	1.344 (34.1)	.300 (7.6)	.475 (12.1)
6	20	1.469 (37.3)	.565 (14.4)	.765 (19.4)
7	20	1.469 (37.3)	.400 (10.2)	.600 (15.2)
8	22	1.625 (41.3)	.690 (17.5)	.890 (22.6)
9	22	1.625 (41.3)	.500 (12.7)	.700 (17.8)
10	22	1.625 (41.3)	.400 (10.2)	.525 (13.3)
11	24	1.750 (44.5)	.815 (20.7)	1.015 (25.8)
12	24	1.750 (44.5)	.595 (15.1)	.815 (20.7)
13	28	2.000 (50.8)	.980 (24.9)	1.180 (30.0)
14	28	2.000 (50.8)	.780 (19.8)	.980 (24.9)
15	32	2.250 (57.2)	1.230 (31.2)	1.430 (36.3)
16	32	2.250 (57.2)	1.030 (26.2)	1.230 (31.2)
17	36	2.500 (63.5)	1.470 (37.3)	1.670 (42.4)
18	36	2.500 (63.5)	1.270 (32.3)	1.470 (37.3)
19	40	2.750 (69.9)	1.660 (42.2)	1.860 (47.2)
20	40	2.750 (69.9)	1.400 (35.6)	1.660 (42.2)

1. For complete dimensions see applicable Military Specification.
2. Metric dimensions (mm) are indicated in parentheses.
3. Cable range is defined as the accommodations range for the wire bundle or cable.
Dimensions shown are not intended for inspection criteria.
4. Approx. Chain Lengths:
Dash No. 1-7 = 5.0 (127.0)
Dash No. 8-20 = 6.0 (152.4)

AS85049/5 Style 3 Environmental Backshells

**Glenair Connector
Designator C**

**MIL-C-22992
Classes C, J, and R**

M85049/5 W 10 A 3

Basic Part No. _____
 Body and Cap Finish _____
 A = Anodize
 W = 1,000 Hour Cadmium Olive Drab
 Over Electroless Nickel

Style 3
 Type (A or B)
 Dash Number
 (Table II)

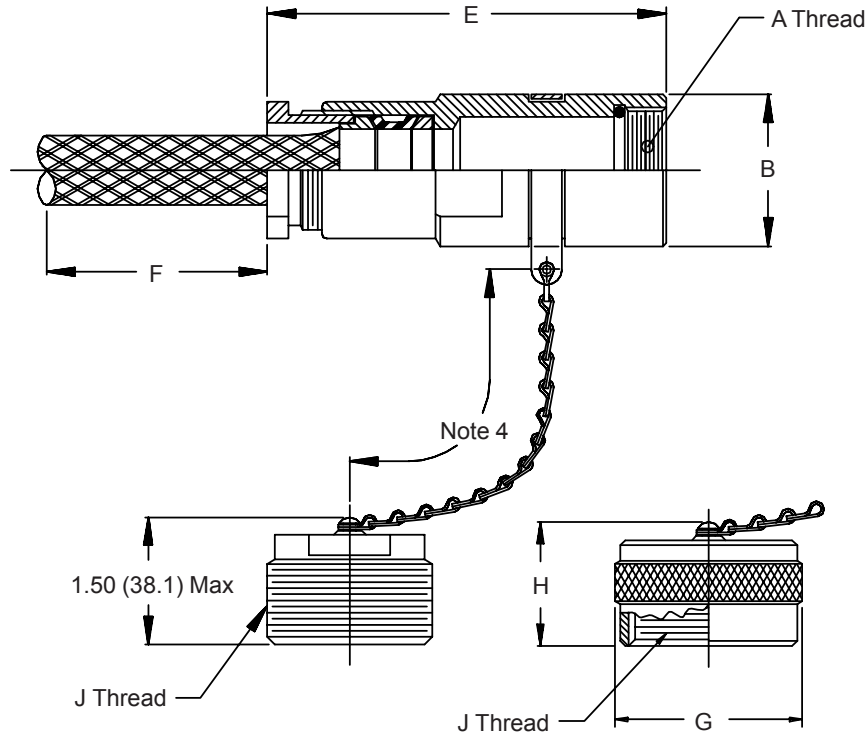

TYPE A - Plug Cap
For use with MS17344

TYPE B - Receptacle Cap
For use with MS17343,
MS17345, and MS17347

TABLE I

Shell Size	A Thread Class 2B-LH	B Dia ±.015 (.4)	G Dia Max	H Max	J Thread (plated) Class 2 (A or B)
12	.7500 - 20 UNEF	.933 (23.7)	1.094 (27.8)	.765 (19.4)	0.875-0.1P-0.2L-DS
18	1.1250 - 18 UNEF	1.307 (33.2)	1.469 (37.3)	.980 (24.9)	1.250-0.1P-0.2L-DS
20	1.2500 - 18 UNEF	1.433 (36.4)	1.562 (39.7)	.980 (24.9)	1.375-0.1P-0.2L-DS
22	1.3750 - 18 UNEF	1.557 (39.5)	1.688 (42.9)	.980 (24.9)	1.500-0.1P-0.2L-DS
24	1.6250 - 18 UNEF	1.807 (45.9)	1.938 (49.2)	.980 (24.9)	1.750-0.1P-0.2L-DS
28	1.8750 - 16 UN	2.057 (52.2)	2.219 (56.4)	.980 (24.9)	2.000-0.1P-0.2L-DS
32	2.0625 - 16 UNS	2.307 (58.6)	2.469 (62.7)	.980 (24.9)	2.250-0.1P-0.2L-DS
36	2.3125 - 16 UNS	2.557 (64.9)	2.719 (69.1)	.980 (24.9)	2.500-0.1P-0.2L-DS
40	2.6250 - 16 UN	2.875 (73.0)	2.969 (75.4)	.980 (24.9)	2.750-0.1P-0.2L-DS

AS85049/5 Style 3
Environmental Backshells



Environmental
Backshells

TABLE II

Dash No.	Shell Size	Cable Range		E Max	F Appr. Free Length
		Min	Max		
1	12	.160 (4.1)	.222 (5.6)	2.752 (69.9)	2.406 (61.1)
2	18	.511 (13.0)	.605 (15.4)	3.712 (94.3)	5.188 (131.8)
3	18	.436 (11.1)	.530 (13.5)	3.712 (94.3)	4.688 (119.1)
4	18	.306 (7.8)	.375 (9.5)	3.502 (89.0)	3.844 (97.6)
5	18	.219 (5.6)	.281 (7.1)	3.471 (88.2)	2.844 (72.2)
6	20	.605 (15.4)	.699 (17.8)	4.024 (102.2)	6.188 (157.2)
7	20	.511 (13.0)	.605 (15.4)	3.841 (97.6)	5.188 (131.8)
8	20	.361 (9.2)	.455 (11.6)	4.024 (102.2)	4.188 (106.4)
9	22	.715 (18.2)	.828 (21.0)	4.087 (103.8)	6.688 (169.9)
10	22	.449 (11.4)	.562 (14.3)	4.087 (103.8)	5.188 (131.8)
11	22	.316 (8.0)	.405 (10.3)	3.841 (97.6)	3.688 (93.7)
12	24	.692 (17.6)	.805 (20.4)	4.150 (105.4)	6.688 (169.9)
13	24	.637 (16.2)	.750 (19.1)	4.150 (105.4)	6.688 (169.9)
14	24	.517 (13.1)	.630 (16.0)	4.150 (105.4)	5.688 (144.5)
15	28	.984 (25.0)	1.109 (28.2)	4.212 (107.0)	7.688 (195.3)
16	28	.875 (22.2)	1.000 (25.4)	4.212 (107.0)	7.188 (182.6)
17	28	.755 (19.2)	.880 (22.4)	4.212 (107.0)	6.688 (169.9)
18	28	.637 (16.2)	.750 (19.1)	4.150 (105.4)	6.688 (169.9)
19	28	.567 (14.4)	.680 (17.3)	4.150 (105.4)	6.688 (169.9)
20	28	.436 (11.1)	.530 (13.5)	3.966 (100.7)	4.688 (119.1)
21	28	.306 (7.8)	.375 (9.5)	3.799 (96.5)	3.844 (97.6)
22	32	1.105 (28.1)	1.230 (31.2)	4.275 (108.6)	8.188 (208.0)
23	32	1.005 (25.5)	1.130 (28.7)	4.275 (108.6)	7.188 (182.6)
24	32	.930 (23.6)	1.055 (26.8)	4.212 (107.0)	7.688 (195.3)
25	32	.857 (21.8)	.970 (24.6)	4.150 (105.4)	7.188 (182.6)
26	32	.755 (19.2)	.880 (22.4)	4.212 (107.0)	6.688 (169.9)
27	32	.637 (16.2)	.750 (19.1)	4.150 (105.4)	6.688 (169.9)
28	32	.436 (11.1)	.530 (13.5)	3.966 (100.7)	4.688 (119.1)
29	32	.306 (7.8)	.375 (9.5)	3.846 (97.7)	3.844 (97.6)
30	36	1.320 (33.5)	1.445 (36.7)	4.337 (110.2)	9.688 (246.1)
31	36	1.250 (31.8)	1.375 (34.9)	4.337 (110.2)	9.688 (246.1)
32	36	1.185 (30.1)	1.310 (33.3)	4.275 (108.6)	8.688 (220.7)
33	36	1.105 (28.1)	1.230 (31.2)	4.275 (108.6)	8.188 (208.0)
34	36	1.055 (26.8)	1.180 (30.0)	4.275 (108.6)	8.188 (208.0)
35	36	.984 (25.0)	1.109 (28.2)	4.212 (107.0)	7.688 (195.3)
36	36	.857 (21.8)	.970 (24.6)	4.154 (105.5)	7.188 (182.6)
37	40	1.815 (46.1)	1.940 (49.3)	5.673 (144.1)	13.688 (347.7)
38	40	1.700 (43.2)	1.825 (46.4)	5.673 (144.1)	13.688 (347.7)
39	40	1.605 (40.8)	1.730 (43.9)	5.673 (144.1)	13.688 (347.7)
40	40	1.531 (38.9)	1.656 (42.1)	5.373 (136.5)	12.688 (322.3)

1. For complete dimensions see applicable Military Specification.
2. Metric dimensions (mm) are indicated in parentheses.
3. Cable range is defined as the accommodations range for the wire bundle or cable. Dimensions shown are not intended for inspection criteria.
4. Approx. Chain Lengths:
 Dash No. 1-8 = 5.0 (127.0)
 Dash No. 9-40 = 6.0 (152.4).



AS85049/7 and MS3189B Environmental Backshells

Glenair Connector Designator A

MIL-DTL-5015 Series 3400,
MIL-DTL-26482 Series 2,
AS81703 Series 3,
MIL-DTL-83723 Series I &
III, 40M39569, DEF 5326-3,
EN 2997, EN 3646,
ESC 10, ESC 11, LN 29504,
NFC93422 Series HE302,
PAN 6432-1, PAN 6432-2,
PATT 602

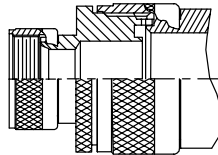

STYLE 2

1. For complete dimensions see applicable Military Specification.
2. Metric dimensions (mm) are indicated in parentheses.
3. When maximum cable entry is exceeded, Style 2 will be supplied.
4. Cable range is defined as the accommodations range for the wire bundle or cable.
Dimensions shown are not intended for inspection criteria.

M85049/7-21 N
Basic Part No. _____
Dash No. _____
Finish and Material
B = Black Cadmium, Stainless Steel
N = Electroless Nickel, Aluminum
S = Passivated Stainless Steel
W = 1,000 Hr. Cad. Olive Drab Over Electroless Nickel

MS3189B 21 N Superceded Part Number
Basic Part No. _____
Dash No. _____
Finish (Material is Aluminum Only)
A = Cadmium Olive Drab over Nickel
C = Cadmium Olive Drab
N = Electroless Nickel

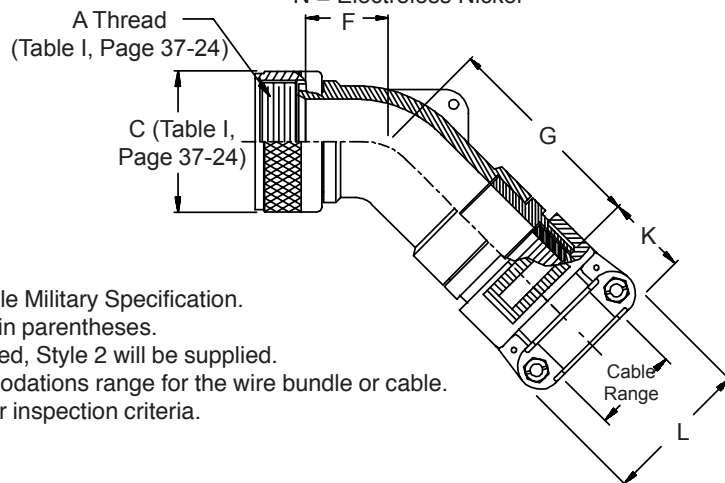

TABLE II

Dash No.	Shell Size	F Max	G Max	K Ref.	L Max	Cable Range		M85049/42 Ref
						Min	Max	
1	03	.688 (17.5)	1.852 (47.0)	1.027 (26.1)	.957 (24.3)	.125 (3.2)	.250 (6.4)	4
2	03	1.500 (38.1)	1.972 (50.1)	1.027 (26.1)	1.145 (29.1)	.250 (6.4)	.437 (11.1)	6
3	08	.625 (15.9)	1.244 (31.6)	1.027 (26.1)	.957 (24.3)	.125 (3.2)	.250 (6.4)	4
4	10	.688 (17.5)	1.912 (48.6)	1.027 (26.1)	.957 (24.3)	.125 (3.2)	.312 (7.9)	4
5	10	.688 (17.5)	1.307 (33.2)	1.027 (26.1)	1.145 (29.1)	.250 (6.4)	.375 (9.5)	6
6	12	.750 (19.1)	1.972 (50.1)	1.027 (26.1)	.957 (24.3)	.125 (3.2)	.312 (7.9)	4
7	12	.750 (19.1)	1.972 (50.1)	1.027 (26.1)	1.145 (29.1)	.250 (6.4)	.437 (11.1)	6
8	12	.750 (19.1)	1.972 (50.1)	1.027 (26.1)	1.332 (33.8)	.350 (8.9)	.500 (12.7)	10
9	14	.812 (20.6)	2.062 (52.4)	1.027 (26.1)	1.145 (29.1)	.250 (6.4)	.437 (11.1)	6
10	14	.812 (20.6)	1.717 (43.6)	1.027 (26.1)	1.332 (33.8)	.350 (8.9)	.575 (14.6)	10
11	16	.906 (23.0)	2.172 (55.2)	1.027 (26.1)	1.145 (29.1)	.250 (6.4)	.437 (11.1)	6
12	16	.906 (23.0)	1.812 (46.0)	1.059 (26.9)	1.551 (39.4)	.500 (12.7)	.700 (17.8)	12
13	18	1.093 (27.8)	2.362 (60.0)	1.027 (26.1)	1.332 (33.8)	.350 (8.9)	.625 (15.9)	10
14	18	1.093 (27.8)	2.000 (50.8)	1.156 (29.4)	1.770 (45.0)	.625 (15.9)	.779 (19.8)	16
15	20	1.093 (27.8)	2.362 (60.0)	1.027 (26.1)	1.332 (33.8)	.350 (8.9)	.625 (15.9)	10
16	20	1.093 (27.8)	2.000 (50.8)	1.156 (29.4)	1.770 (45.0)	.625 (15.9)	.904 (23.0)	16
17	22	1.188 (30.2)	2.512 (63.8)	1.059 (26.9)	1.551 (39.4)	.500 (12.7)	.750 (19.1)	12
18	22	1.188 (30.2)	2.155 (54.7)	1.375 (34.9)	2.113 (53.7)	.875 (22.2)	1.029 (26.1)	20
19	24	1.188 (30.2)	2.512 (63.8)	1.059 (26.9)	1.551 (39.4)	.500 (12.7)	.750 (19.1)	12
20	24	1.188 (30.2)	2.155 (54.7)	1.375 (34.9)	2.113 (53.7)	.875 (22.2)	1.144 (29.1)	20
21	28	1.312 (33.3)	2.562 (65.1)	1.156 (33.7)	1.770 (45.0)	.625 (15.9)	.937 (23.8)	16

**AS85049/7 and MS3189B
Environmental Backshells**



**Environmental
Backshells**

TABLE II (Continued)

Dash No.	Shell Size	F		G		K		L		Cable Range			M85049/42 Ref	
		Max		Max		Ref.		Max		Min	Max			
22	28	1.312	(33.3)	2.218	(56.3)	1.500	(38.1)	2.363	(60.0)	1.000	(25.4)	1.375	(34.9)	24
23	32	1.375	(34.9)	2.662	(67.6)	1.156	(29.4)	1.770	(45.0)	.625	(15.9)	.937	(23.8)	16
24	32	1.375	(34.9)	2.662	(67.6)	1.375	(34.9)	2.113	(53.7)	.875	(22.2)	1.250	(31.8)	20
25	32	1.375	(34.9)	2.312	(58.7)	1.781	(45.2)	2.770	(70.4)	1.250	(31.8)	1.625	(41.3)	28
26	36	1.406	(35.7)	2.752	(69.9)	1.156	(29.4)	1.770	(45.0)	.625	(15.9)	.937	(23.8)	16
27	36	1.406	(35.7)	2.752	(69.9)	1.500	(38.1)	2.363	(60.0)	1.000	(25.4)	1.375	(34.9)	24
28	36	1.406	(35.7)	2.406	(61.1)	1.830	(46.5)	3.020	(76.7)	1.437	(36.5)	1.840	(46.7)	32
29	40	2.156	(54.8)	2.752	(69.9)	1.156	(29.4)	1.770	(45.0)	.625	(15.9)	.937	(23.8)	16
30	40	2.156	(54.8)	2.752	(69.9)	1.500	(38.1)	2.363	(60.0)	1.000	(25.4)	1.375	(34.9)	24
31	40	2.156	(54.8)	2.406	(61.1)	1.830	(46.5)	3.020	(76.7)	1.437	(36.5)	1.875	(47.6)	32
32	44	2.156	(54.8)	2.752	(69.9)	1.156	(29.4)	1.770	(45.0)	.625	(15.9)	.937	(23.8)	16
33	44	2.156	(54.8)	2.752	(69.9)	1.500	(38.1)	2.363	(60.0)	1.000	(25.4)	1.375	(34.9)	24
34	44	2.156	(54.8)	2.406	(61.1)	1.830	(46.5)	3.020	(76.7)	1.437	(36.5)	1.875	(47.6)	32
35	48	2.156	(54.8)	2.752	(69.9)	1.156	(29.4)	1.770	(45.0)	.625	(15.9)	.937	(23.8)	16
36	48	2.156	(54.8)	2.752	(69.9)	1.500	(38.1)	2.363	(60.0)	1.000	(25.4)	1.375	(34.9)	24
37	48	2.156	(54.8)	2.406	(61.1)	1.830	(46.5)	3.020	(76.7)	1.437	(36.5)	1.875	(47.6)	32
38	61	1.188	(30.2)	2.512	(63.8)	1.059	(26.9)	1.551	(39.4)	.500	(12.7)	.750	(19.1)	12
39	61	1.188	(30.2)	2.155	(54.7)	1.375	(34.9)	2.113	(53.7)	.875	(22.2)	1.184	(30.1)	20
40	16	.906	(23.0)	2.172	(55.2)	1.027	(26.1)	1.332	(33.8)	.350	(8.9)	.625	(15.9)	10
41	18	1.093	(27.8)	2.362	(60.0)	1.027	(26.1)	.957	(24.3)	.125	(3.2)	.312	(7.9)	4
42	18	1.093	(27.8)	2.362	(60.0)	1.027	(26.1)	1.145	(29.1)	.250	(6.4)	.437	(11.1)	6
43	20	1.093	(27.8)	2.362	(60.0)	1.027	(26.1)	1.145	(29.1)	.250	(6.4)	.437	(11.1)	6
44	22	1.188	(30.2)	2.512	(63.8)	1.027	(26.1)	.957	(24.3)	.125	(3.2)	.312	(7.9)	4
45	22	1.188	(30.2)	2.512	(63.8)	1.027	(26.1)	1.145	(29.1)	.250	(6.4)	.437	(11.1)	6
46	24	1.188	(30.2)	2.512	(63.8)	1.027	(26.1)	1.332	(33.8)	.350	(8.9)	.625	(15.9)	10
47	36	1.406	(35.7)	2.752	(69.9)	1.059	(26.9)	1.551	(39.4)	.500	(12.7)	.750	(19.1)	12
48	40	2.156	(54.8)	2.752	(69.9)	1.059	(26.9)	1.551	(39.4)	.500	(12.7)	.750	(19.1)	12
49*	10	1.500	(38.1)	1.972	(50.1)	1.027	(26.1)	1.145	(29.1)	.250	(6.4)	.437	(11.1)	6
50*	14	1.842	(46.8)	2.362	(60.0)	1.059	(26.9)	1.551	(39.4)	.500	(12.7)	.750	(19.1)	12
51*	16	1.938	(49.2)	2.512	(63.8)	1.156	(29.4)	1.770	(45.0)	.625	(15.9)	.937	(23.8)	16
52	18	1.093	(27.8)	2.362	(60.0)	1.059	(26.9)	1.551	(39.4)	.500	(12.7)	.750	(19.1)	12
53	61	1.188	(30.2)	2.512	(63.8)	1.156	(29.4)	1.770	(45.0)	.625	(15.9)	.937	(23.8)	16
54	20	1.093	(27.8)	2.362	(60.0)	1.059	(26.9)	1.551	(39.4)	.500	(12.7)	.750	(19.1)	12
55*	20	2.061	(52.3)	2.562	(65.1)	1.375	(34.9)	2.113	(53.7)	.875	(22.2)	1.250	(31.8)	20
56	22	1.188	(30.2)	2.512	(63.8)	1.027	(26.1)	1.332	(33.8)	.350	(8.9)	.625	(15.9)	10
57	22	1.188	(30.2)	2.512	(63.8)	1.156	(29.4)	1.770	(45.0)	.625	(15.9)	.937	(23.8)	16
58*	22	2.061	(52.3)	2.562	(65.1)	1.375	(34.9)	2.113	(53.7)	.875	(22.2)	1.250	(31.8)	20
59	24	1.188	(30.2)	2.512	(63.8)	1.156	(29.4)	1.770	(45.0)	.625	(15.9)	.937	(23.8)	16
60	28	1.312	(33.3)	2.562	(65.1)	1.059	(26.9)	1.551	(39.4)	.500	(12.7)	.750	(19.1)	12
61	28	1.312	(33.3)	2.562	(65.1)	1.375	(34.9)	2.113	(53.7)	.875	(22.2)	1.250	(31.8)	20
62	32	1.375	(34.9)	2.662	(67.6)	1.500	(38.1)	2.363	(60.0)	1.000	(25.4)	1.375	(34.9)	24
63	36	1.406	(35.7)	2.752	(69.9)	1.375	(34.9)	2.113	(53.7)	.875	(22.2)	1.250	(31.8)	20
64	36	1.406	(35.7)	2.752	(69.9)	1.781	(45.2)	2.770	(70.4)	1.250	(31.8)	1.625	(41.3)	28
65	40	2.156	(54.8)	2.752	(69.9)	1.375	(34.9)	2.113	(53.7)	.875	(22.2)	1.250	(31.8)	20
66	40	2.156	(54.8)	2.752	(69.9)	1.781	(45.2)	2.770	(70.4)	1.250	(31.8)	1.625	(41.3)	28
67	44	2.156	(54.8)	2.752	(69.9)	1.375	(34.9)	2.113	(53.7)	.875	(22.2)	1.250	(31.8)	20
68	44	2.156	(54.8)	2.752	(69.9)	1.781	(45.2)	2.770	(70.4)	1.250	(31.8)	1.625	(41.3)	28
69	48	2.156	(54.8)	2.752	(69.9)	1.375	(34.9)	2.113	(53.7)	.875	(22.2)	1.250	(31.8)	20
70	48	2.156	(54.8)	2.752	(69.9)	1.781	(45.2)	2.770	(70.4)	1.250	(31.8)	1.625	(41.3)	28
71*	12	1.654	(42.0)	2.173	(55.2)	1.027	(26.1)	1.332	(33.8)	.350	(8.9)	.625	(15.9)	10
72*	18	1.938	(49.2)	2.512	(63.8)	1.156	(29.4)	1.770	(45.0)	.625	(15.9)	.937	(23.8)	16
73*	24	2.061	(52.3)	2.562	(65.1)	1.375	(34.9)	2.113	(53.7)	.875	(22.2)	1.250	(31.8)	20
74	14	.812	(20.6)	2.062	(52.4)	1.027	(26.1)	.957	(24.3)	.125	(3.2)	.312	(7.9)	4
75	16	.906	(23.0)	2.172	(55.2)	1.027	(26.1)	.957	(24.3)	.125	(3.2)	.312	(7.9)	4

© 2005 Glenair, Inc.

CAGE Code 06324

Printed in U.S.A.

Glenair Connector Designator A

MIL-DTL-5015 Series 3400,
MIL-DTL-26482 Series 2,
AS81703 Series 3,
MIL-DTL-83723 Series I & III,
40M39569, DEF 5326-3,
EN 2997, EN 3646,
ESC 10, ESC 11, LN 29504,
NFC93422 Series HE302,
PAN 6432-1, PAN 6432-2,
PATT 602

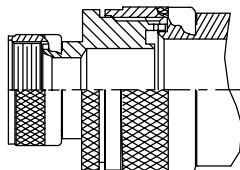

STYLE 2

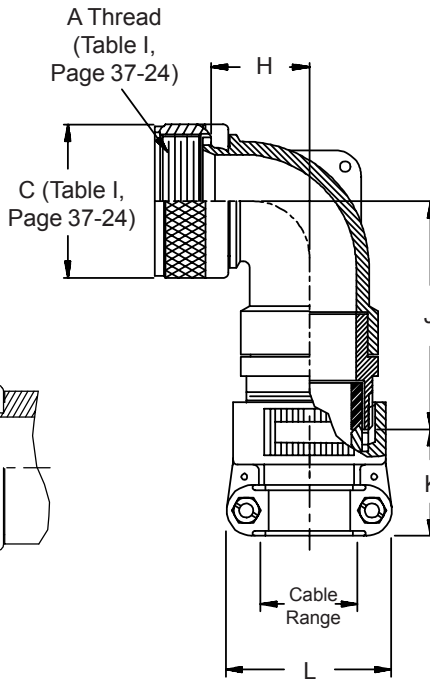

M85049/9-21 N

Basic Part No. _____
Dash No. _____
Finish and Material _____
B = Black Cadmium, Stainless Steel
N = Electroless Nickel, Aluminum
S = Passivated Stainless Steel
W = 1,000 Hour Cadmium Olive Drab
Over Electroless Nickel, Aluminum

Superseded Part Number

MS3188B 21 N

Basic Part No. _____
Dash No. _____
Finish (Material is Aluminum Only) _____
A = Cadmium Olive Drab over Nickel
C = Cadmium Olive Drab
N = Electroless Nickel

1. For complete dimensions see applicable Military Specification.
2. Metric dimensions (mm) are indicated in parentheses.
3. When maximum cable entry is exceeded, Style 2 will be supplied.
4. Cable range is defined as the accommodations range for the wire bundle or cable. Dimensions shown are not intended for inspection criteria.

TABLE II

Dash No.	Shell Size	H		J		K Ref.	L Max	Cable Range		M85049/42 Ref				
		Max	()	Max	()			Min	Max					
1	03	.761	(19.3)	1.862	(47.3)	1.027	(26.1)	.125	(3.2)	.250	(6.4)	4		
2	03	1.511	(38.4)	1.382	(35.1)	1.027	(26.1)	1.145	(29.1)	.250	(6.4)	.437	(11.1)	6
3	08	.666	(16.9)	1.262	(32.1)	1.027	(26.1)	.957	(24.3)	.125	(3.2)	.250	(6.4)	4
4	10	.761	(19.3)	1.982	(50.3)	1.027	(26.1)	.957	(24.3)	.125	(3.2)	.312	(7.9)	4
5	10	.761	(19.3)	1.382	(35.1)	1.027	(26.1)	1.145	(29.1)	.250	(6.4)	.375	(9.5)	6
6	12	.766	(19.5)	2.002	(50.9)	1.027	(26.1)	.957	(24.3)	.125	(3.2)	.312	(7.9)	4
7	12	.766	(19.5)	2.002	(50.9)	1.027	(26.1)	1.145	(29.1)	.250	(6.4)	.437	(11.1)	6
8	12	.766	(19.5)	1.397	(35.5)	1.027	(26.1)	1.332	(33.8)	.350	(8.9)	.500	(12.7)	10
9	14	.866	(22.0)	2.072	(52.6)	1.027	(26.1)	1.145	(29.1)	.250	(6.4)	.437	(11.1)	6
10	14	.866	(22.0)	1.717	(43.6)	1.027	(26.1)	1.332	(33.8)	.350	(8.9)	.575	(14.6)	10
11	16	1.051	(26.7)	2.162	(54.9)	1.027	(26.1)	1.145	(29.1)	.250	(6.4)	.437	(11.1)	6
12	16	1.051	(26.7)	1.807	(45.9)	1.059	(26.9)	1.551	(39.4)	.500	(12.7)	.700	(17.8)	12
13	18	1.141	(29.0)	2.332	(59.2)	1.027	(26.1)	1.332	(33.8)	.350	(8.9)	.625	(15.9)	10
14	18	1.141	(29.0)	1.982	(50.3)	1.156	(29.4)	1.770	(45.0)	.625	(15.9)	.779	(19.8)	16
15	20	1.141	(29.0)	2.332	(59.2)	1.027	(26.1)	1.332	(33.8)	.350	(8.9)	.625	(15.9)	10
16	20	1.141	(29.0)	1.982	(50.3)	1.156	(29.4)	1.770	(45.0)	.625	(15.9)	.904	(23.0)	16
17	22	1.291	(32.8)	2.442	(62.0)	1.059	(26.9)	1.551	(39.4)	.500	(12.7)	.750	(19.1)	12
18	22	1.291	(32.8)	2.087	(53.0)	1.375	(34.9)	2.113	(53.7)	.875	(22.2)	1.029	(26.1)	20
19	24	1.291	(32.8)	2.442	(62.0)	1.059	(26.9)	1.551	(39.4)	.500	(12.7)	.750	(19.1)	12
20	24	1.291	(32.8)	2.087	(53.0)	1.375	(34.9)	2.113	(53.7)	.875	(22.2)	1.144	(29.1)	20
21	28	1.391	(35.3)	2.612	(66.3)	1.156	(33.7)	1.770	(45.0)	.625	(15.9)	.937	(23.8)	16

AS85049/9 and MS3188B Environmental Backshells



Environmental Backshells

TABLE II (Continued)

Dash No.	Shell Size	H		J		K		L		Cable Range			M85049/42 Ref	
		Max	()	Max	()	Ref.	()	Max	()	Min	()	Max		()
22	28	1.391	(35.3)	2.257	(57.3)	1.500	(38.1)	2.363	(60.0)	1.000	(25.4)	1.375	(34.9)	24
23	32	1.741	(44.2)	2.862	(72.7)	1.156	(29.4)	1.770	(45.0)	.625	(15.9)	.937	(23.8)	16
24	32	1.741	(44.2)	2.862	(72.7)	1.375	(34.9)	2.113	(53.7)	.875	(22.2)	1.250	(31.8)	20
25	32	1.741	(44.2)	2.507	(63.7)	1.781	(45.2)	2.770	(70.4)	1.250	(31.8)	1.625	(41.3)	28
26	36	1.941	(49.3)	2.832	(71.9)	1.156	(29.4)	1.770	(45.0)	.625	(15.9)	.937	(23.8)	16
27	36	1.941	(49.3)	2.832	(71.9)	1.500	(38.1)	2.363	(60.0)	1.000	(25.4)	1.375	(34.9)	24
28	36	1.941	(49.3)	2.477	(62.9)	1.830	(46.5)	3.020	(76.7)	1.437	(36.5)	1.840	(46.7)	32
29	40	2.691	(68.4)	2.832	(71.9)	1.156	(29.4)	1.770	(45.0)	.625	(15.9)	.937	(23.8)	16
30	40	2.691	(68.4)	2.832	(71.9)	1.500	(38.1)	2.363	(60.0)	1.000	(25.4)	1.375	(34.9)	24
31	40	2.691	(68.4)	2.477	(62.9)	1.830	(46.5)	3.020	(76.7)	1.437	(36.5)	1.875	(47.6)	32
32	44	2.691	(68.4)	2.832	(71.9)	1.156	(29.4)	1.770	(45.0)	.625	(15.9)	.937	(23.8)	16
33	44	2.691	(68.4)	2.832	(71.9)	1.500	(38.1)	2.363	(60.0)	1.000	(25.4)	1.375	(34.9)	24
34	44	2.691	(68.4)	2.477	(62.9)	1.830	(46.5)	3.020	(76.7)	1.437	(36.5)	1.875	(47.6)	32
35	48	2.691	(68.4)	2.832	(71.9)	1.156	(29.4)	1.770	(45.0)	.625	(15.9)	.937	(23.8)	16
36	48	2.691	(68.4)	2.832	(71.9)	1.500	(38.1)	2.363	(60.0)	1.000	(25.4)	1.375	(34.9)	24
37	48	2.691	(68.4)	2.477	(62.9)	1.830	(46.5)	3.020	(76.7)	1.437	(36.5)	1.875	(47.6)	32
38	61	1.291	(32.8)	2.442	(62.0)	1.059	(26.9)	1.551	(39.4)	.500	(12.7)	.750	(19.1)	12
39	61	1.291	(32.8)	2.087	(53.0)	1.375	(34.9)	2.113	(53.7)	.875	(22.2)	1.184	(30.1)	20
40	16	1.051	(26.7)	2.162	(54.9)	1.027	(26.1)	1.332	(33.8)	.350	(8.9)	.625	(15.9)	10
41	18	1.141	(29.0)	2.332	(59.2)	1.027	(26.1)	.957	(24.3)	.125	(3.2)	.312	(7.9)	4
42	18	1.141	(29.0)	2.332	(59.2)	1.027	(26.1)	1.145	(29.1)	.250	(6.4)	.437	(11.1)	6
43	20	1.141	(29.0)	2.332	(59.2)	1.027	(26.1)	1.145	(29.1)	.250	(6.4)	.437	(11.1)	6
44	22	1.291	(32.8)	2.442	(62.0)	1.027	(26.1)	.957	(24.3)	.125	(3.2)	.312	(7.9)	4
45	22	1.291	(32.8)	2.442	(62.0)	1.027	(26.1)	1.145	(29.1)	.250	(6.4)	.437	(11.1)	6
46	24	1.291	(32.8)	2.442	(62.0)	1.027	(26.1)	1.332	(33.8)	.350	(8.9)	.625	(15.9)	10
47	36	1.941	(49.3)	2.832	(71.9)	1.059	(26.9)	1.551	(39.4)	.500	(12.7)	.750	(19.1)	12
48	40	1.941	(49.3)	2.832	(71.9)	1.059	(26.9)	1.551	(39.4)	.500	(12.7)	.750	(19.1)	12
49*	10	1.516	(38.5)	2.002	(50.9)	1.027	(26.1)	1.145	(29.1)	.250	(6.4)	.437	(11.1)	6
50*	14	1.891	(48.0)	2.332	(59.2)	1.059	(26.9)	1.551	(39.4)	.500	(12.7)	.750	(19.1)	12
51*	16	2.041	(51.8)	2.442	(62.0)	1.156	(29.4)	1.770	(45.0)	.625	(15.9)	.937	(23.8)	16
52	18	1.141	(29.0)	2.332	(59.2)	1.059	(26.9)	1.551	(39.4)	.500	(12.7)	.750	(19.1)	12
53	61	1.291	(32.8)	2.087	(53.0)	1.156	(29.4)	1.770	(45.0)	.625	(15.9)	.937	(23.8)	16
54	20	1.141	(29.0)	2.332	(59.2)	1.059	(26.9)	1.551	(39.4)	.500	(12.7)	.750	(19.1)	12
55*	20	2.141	(54.4)	2.612	(66.3)	1.375	(34.9)	2.113	(53.7)	.875	(22.2)	1.250	(31.8)	20
56	22	1.291	(32.8)	2.442	(62.0)	1.027	(26.1)	1.332	(33.8)	.350	(8.9)	.625	(15.9)	10
57	22	1.291	(32.8)	2.442	(62.0)	1.156	(29.4)	1.770	(45.0)	.625	(15.9)	.937	(23.8)	16
58*	22	2.141	(54.4)	2.612	(66.3)	1.375	(34.9)	2.113	(53.7)	.875	(22.2)	1.250	(31.8)	20
59	24	1.291	(32.8)	2.442	(62.0)	1.156	(29.4)	1.770	(45.0)	.625	(15.9)	.937	(23.8)	16
60	28	1.391	(35.3)	2.612	(66.3)	1.059	(26.9)	1.551	(39.4)	.500	(12.7)	.750	(19.1)	12
61	28	1.391	(35.3)	2.612	(66.3)	1.375	(34.9)	2.113	(53.7)	.875	(22.2)	1.250	(31.8)	20
62	32	1.741	(44.2)	2.862	(72.7)	1.500	(38.1)	2.363	(60.0)	1.000	(25.4)	1.375	(34.9)	24
63	36	1.941	(49.3)	2.832	(71.9)	1.375	(34.9)	2.113	(53.7)	.875	(22.2)	1.250	(31.8)	20
64	36	1.941	(49.3)	2.832	(71.9)	1.781	(45.2)	2.770	(70.4)	1.250	(31.8)	1.625	(41.3)	28
65	40	2.691	(68.4)	2.832	(71.9)	1.375	(34.9)	2.113	(53.7)	.875	(22.2)	1.250	(31.8)	20
66	40	2.691	(68.4)	2.832	(71.9)	1.781	(45.2)	2.770	(70.4)	1.250	(31.8)	1.625	(41.3)	28
67	44	2.691	(68.4)	2.832	(71.9)	1.375	(34.9)	2.113	(53.7)	.875	(22.2)	1.250	(31.8)	20
68	44	2.691	(68.4)	2.832	(71.9)	1.781	(45.2)	2.770	(70.4)	1.250	(31.8)	1.625	(41.3)	28
69	48	2.691	(68.4)	2.832	(71.9)	1.375	(34.9)	2.113	(53.7)	.875	(22.2)	1.250	(31.8)	20
70	48	2.691	(68.4)	2.832	(71.9)	1.781	(45.2)	2.770	(70.4)	1.250	(31.8)	1.625	(41.3)	28
71*	12	1.811	(46.0)	2.162	(54.9)	1.027	(26.1)	1.332	(33.8)	.350	(8.9)	.625	(15.9)	10
72*	18	2.051	(52.1)	2.442	(62.0)	1.156	(29.4)	1.770	(45.0)	.625	(15.9)	.937	(23.8)	16
73*	24	2.151	(54.6)	2.612	(66.3)	1.375	(34.9)	2.116	(53.7)	.875	(22.2)	1.250	(31.8)	20
74	14	.866	(22.0)	2.072	(52.6)	1.027	(26.1)	.957	(24.3)	.125	(3.2)	.312	(7.9)	4
75	16	1.051	(26.7)	2.162	(54.9)	1.027	(26.1)	.957	(24.3)	.125	(3.2)	.312	(7.9)	4

© 2005 Glenair, Inc.

CAGE Code 06324

Printed in U.S.A.



AS85049/11 and MS3437B Environmental Backshells

Glenair Connector Designator A

**MIL-DTL-5015 Series 3400,
MIL-DTL-26482 Series 2,
AS81703 Series 3,
MIL-DTL-83723 Series I &
III, 40M39569, DEF 5326-3,
EN 2997, EN 3646,
ESC 10, ESC 11, LN 29504,
NFC93422 Series HE302,
PAN 6432-1, PAN 6432-2,
PATT 602**

M85049/11-21 N

Basic Part No. ————
Dash No. (Table II) ————

Finish and Material
 B = Black Cadmium, Stainless Steel
 N = Electroless Nickel, Aluminum
 S = Passivated Stainless Steel
 W = 1,000 Hour Cadmium Olive Drab Over
 Electroless Nickel, Aluminum

MS3437B 21 N

Basic Part No. ————
Dash No. (Table II) ————

Superceded Part Number
 Finish (Material is Aluminum Only)
 A = Cadmium Olive Drab over Nickel
 C = Cadmium Olive Drab
 N = Electroless Nickel

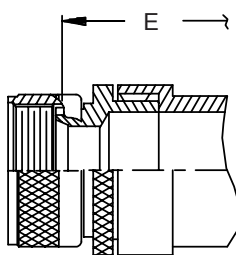

STYLE 2

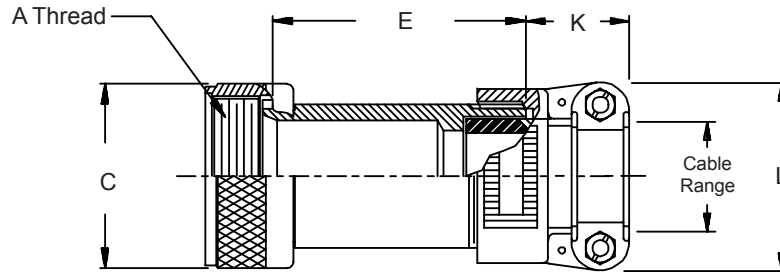

STYLE 1

TABLE I

Shell Size	A Thread Class 2B	C Dia Max
3	.562 - 24 UNEF	.669 (17.0)
8	.500 - 20 UNF	.617 (15.7)
10	.625 - 24 UNEF	.734 (18.6)
12	.750 - 20 UNEF	.858 (21.8)
14	.875 - 20 UNEF	.984 (25.0)
16	1.000 - 20 UNEF	1.112 (28.2)
18	1.062 - 18 UNEF	1.218 (30.9)
20	1.188 - 18 UNEF	1.345 (34.2)
22	1.313 - 18 UNEF	1.468 (37.3)
24	1.438 - 18 UNEF	1.593 (40.5)
28	1.750 - 18 UNS	1.969 (50.0)
32	2.000 - 18 UNS	2.219 (56.4)
36	2.250 - 16 UN	2.469 (62.7)
40	2.500 - 16 UN	2.719 (69.1)
44	2.750 - 16 UN	2.969 (75.4)
48	3.000 - 16 UN	3.219 (81.8)
61	1.500 - 18 UNEF	1.653 (42.0)

1. For complete dimensions see applicable Military Specification.
2. Metric dimensions (mm) are indicated in parentheses.
3. Cable range is defined as the accommodations range for the wire bundle or cable. Dimensions shown are not intended for inspection criteria.
4. When maximum cable entry is exceeded, Style 2 will be supplied.

**AS85049/11 and MS3437B
Environmental Backshells**



Environmental
Backshells

TABLE II

Dash No.	Shell Size	Style	E		K	L		Cable Range				M85049/42	
			Max	(in)	Ref.	Max	(in)	Min	(in)	Max	(in)	Ref	
01	3	1	2.125	(54.0)	1.027	(26.1)	.957	(24.3)	.125	(3.2)	.250	(6.4)	4
02	3	1	3.125	(79.4)	1.027	(26.1)	.957	(24.3)	.125	(3.2)	.250	(6.4)	4
03	3	2	2.875	(73.0)	1.027	(26.1)	1.145	(29.1)	.250	(6.4)	.437	(11.1)	6
04	3	2	3.875	(98.4)	1.027	(26.1)	1.145	(29.1)	.250	(6.4)	.437	(11.1)	6
05	8	1	2.125	(54.0)	1.027	(26.1)	.957	(24.3)	.125	(3.2)	.250	(6.4)	4
06	8	1	3.125	(79.4)	1.027	(26.1)	.957	(24.3)	.125	(3.2)	.250	(6.4)	4
07	8	2	2.875	(73.0)	1.027	(26.1)	1.145	(29.1)	.250	(6.4)	.437	(11.1)	6
08	8	2	3.875	(98.4)	1.027	(26.1)	1.145	(29.1)	.250	(6.4)	.437	(11.1)	6
09	10	1	2.125	(54.0)	1.027	(26.1)	.957	(24.3)	.125	(3.2)	.312	(7.9)	4
10	10	1	3.125	(79.4)	1.027	(26.1)	.957	(24.3)	.125	(3.2)	.312	(7.9)	4
11	10	2	2.875	(73.0)	1.027	(26.1)	1.145	(29.1)	.250	(6.4)	.437	(11.1)	6
12	10	2	3.875	(98.4)	1.027	(26.1)	1.145	(29.1)	.250	(6.4)	.437	(11.1)	6
13	12	1	2.125	(54.0)	1.027	(26.1)	1.145	(29.1)	.250	(6.4)	.437	(11.1)	6
14	12	1	3.125	(79.4)	1.027	(26.1)	1.145	(29.1)	.250	(6.4)	.437	(11.1)	6
15	12	2	2.875	(73.0)	1.027	(26.1)	1.332	(33.8)	.350	(8.9)	.625	(15.9)	10
16	12	2	3.875	(98.4)	1.027	(26.1)	1.332	(33.8)	.350	(8.9)	.625	(15.9)	10
17	14	1	2.125	(54.0)	1.027	(26.1)	1.332	(33.8)	.350	(8.9)	.575	(14.6)	10
18	14	1	3.125	(79.4)	1.027	(26.1)	1.332	(33.8)	.350	(8.9)	.575	(14.6)	10
19	14	2	2.875	(73.0)	1.059	(26.9)	1.551	(39.4)	.500	(12.7)	.750	(19.1)	12
20	14	2	3.875	(98.4)	1.059	(26.9)	1.551	(39.4)	.500	(12.7)	.750	(19.1)	12
21	16	1	2.125	(54.0)	1.059	(26.9)	1.551	(39.4)	.500	(12.7)	.700	(17.8)	12
22	16	1	3.125	(79.4)	1.059	(26.9)	1.551	(39.4)	.500	(12.7)	.700	(17.8)	12
23	16	2	2.875	(73.0)	1.156	(29.4)	1.770	(45.0)	.625	(15.9)	.937	(23.8)	16
24	16	2	3.875	(98.4)	1.156	(29.4)	1.770	(45.0)	.625	(15.9)	.937	(23.8)	16
25	18	1	2.125	(54.0)	1.027	(26.1)	1.332	(33.8)	.350	(8.9)	.625	(15.9)	10
26	18	1	3.125	(79.4)	1.027	(26.1)	1.332	(33.8)	.350	(8.9)	.625	(15.9)	10
27	18	1	2.125	(54.0)	1.059	(26.9)	1.551	(39.4)	.500	(12.7)	.750	(19.1)	12
28	18	1	3.125	(79.4)	1.059	(26.9)	1.551	(39.4)	.500	(12.7)	.750	(19.1)	12
29	18	2	2.875	(73.0)	1.156	(29.4)	1.770	(45.0)	.625	(15.9)	.937	(23.8)	16
30	18	2	3.875	(98.4)	1.156	(29.4)	1.770	(45.0)	.625	(15.9)	.937	(23.8)	16
31	20	1	3.125	(79.4)	1.027	(26.1)	1.332	(33.8)	.350	(8.9)	.625	(15.9)	10
32	20	1	4.125	(104.8)	1.027	(26.1)	1.332	(33.8)	.350	(8.9)	.625	(15.9)	10
33	20	1	3.125	(79.4)	1.059	(26.9)	1.551	(39.4)	.500	(12.7)	.750	(19.1)	12
34	20	1	4.125	(104.8)	1.059	(26.9)	1.551	(39.4)	.500	(12.7)	.750	(19.1)	12
35	20	2	3.875	(98.4)	1.156	(29.4)	1.770	(45.0)	.625	(15.9)	.937	(23.8)	16
36	20	2	4.875	(123.8)	1.156	(29.4)	1.770	(45.0)	.625	(15.9)	.937	(23.8)	16
37	20	2	3.875	(98.4)	1.375	(34.9)	2.113	(53.7)	.875	(22.2)	1.250	(31.8)	20
38	20	2	4.875	(123.8)	1.375	(34.9)	2.113	(53.7)	.875	(22.2)	1.250	(31.8)	20
39	22	1	3.125	(79.4)	1.027	(26.1)	1.332	(33.8)	.350	(8.9)	.625	(15.9)	10
40	22	1	4.125	(104.8)	1.027	(26.1)	1.332	(33.8)	.350	(8.9)	.625	(15.9)	10
41	22	1	3.125	(79.4)	1.059	(26.9)	1.551	(39.4)	.500	(12.7)	.750	(19.1)	12
42	22	1	4.125	(104.8)	1.059	(26.9)	1.551	(39.4)	.500	(12.7)	.750	(19.1)	12
43	22	1	3.125	(79.4)	1.156	(29.4)	1.770	(45.0)	.625	(15.9)	.937	(23.8)	16
44	22	1	4.125	(104.8)	1.156	(29.4)	1.770	(45.0)	.625	(15.9)	.937	(23.8)	16
45	22	2	3.875	(98.4)	1.375	(34.9)	2.113	(53.7)	.875	(22.2)	1.250	(31.8)	20
46	22	2	4.875	(123.8)	1.375	(34.9)	2.113	(53.7)	.875	(22.2)	1.250	(31.8)	20
47	24	1	3.125	(79.4)	1.059	(26.9)	1.551	(39.4)	.500	(12.7)	.750	(19.1)	12
48	24	1	4.125	(104.8)	1.059	(26.9)	1.551	(39.4)	.500	(12.7)	.750	(19.1)	12
49	24	1	3.125	(79.4)	1.156	(29.4)	1.770	(45.0)	.625	(15.9)	.812	(20.6)	16
50	24	1	4.125	(104.8)	1.156	(29.4)	1.770	(45.0)	.625	(15.9)	.812	(20.6)	16
51	24	1	3.125	(79.4)	1.156	(29.4)	1.770	(45.0)	.625	(15.9)	.937	(23.8)	16
52	24	1	4.125	(104.8)	1.156	(29.4)	1.770	(45.0)	.625	(15.9)	.937	(23.8)	16

Table continued on the next page.



AS85049/11 and MS3437B Environmental Backshells

TABLE II (Continued)

Dash No.	Shell Size	Style	E		K		L		Cable Range		M85049/42 Ref		
			Max	()	Ref.	()	Max	()	Min	Max			
53	24	2	3.875	(98.4)	1.375	(34.9)	2.113	(53.7)	.875	(22.2)	1.250	(31.8)	20
54	24	2	4.875	(123.8)	1.375	(34.9)	2.113	(53.7)	.875	(22.2)	1.250	(31.8)	20
55	28	1	3.125	(79.4)	1.059	(26.9)	1.551	(39.4)	.500	(12.7)	.750	(19.1)	12
56	28	1	4.125	(104.8)	1.059	(26.9)	1.551	(39.4)	.500	(12.7)	.750	(19.1)	12
57	28	1	3.125	(79.4)	1.156	(29.4)	1.770	(45.0)	.625	(15.9)	.937	(23.8)	16
58	28	1	4.125	(104.8)	1.156	(29.4)	1.770	(45.0)	.625	(15.9)	.937	(23.8)	16
59	28	1	3.125	(79.4)	1.375	(34.9)	2.113	(53.7)	.875	(22.2)	1.250	(31.8)	20
60	28	1	4.125	(104.8)	1.375	(34.9)	2.113	(53.7)	.875	(22.2)	1.250	(31.8)	20
61	28	1	3.125	(79.4)	1.500	(38.1)	2.363	(60.0)	1.000	(25.4)	1.375	(34.9)	24
62	28	1	4.125	(104.8)	1.500	(38.1)	2.363	(60.0)	1.000	(25.4)	1.375	(34.9)	24
63	32	1	3.125	(79.4)	1.156	(29.4)	1.770	(45.0)	.625	(15.9)	.937	(23.8)	16
64	32	1	4.125	(104.8)	1.156	(29.4)	1.770	(45.0)	.625	(15.9)	.937	(23.8)	16
65	32	1	3.125	(79.4)	1.375	(34.9)	2.113	(53.7)	.875	(22.2)	1.250	(31.8)	20
66	32	1	4.125	(104.8)	1.375	(34.9)	2.113	(53.7)	.875	(22.2)	1.250	(31.8)	20
67	32	1	3.125	(79.4)	1.500	(38.1)	2.363	(60.0)	1.000	(25.4)	1.375	(34.9)	24
68	32	1	4.125	(104.8)	1.500	(38.1)	2.363	(60.0)	1.000	(25.4)	1.375	(34.9)	24
69	32	1	3.125	(79.4)	1.781	(45.2)	2.770	(70.4)	1.250	(31.8)	1.625	(41.3)	28
70	32	1	4.125	(104.8)	1.781	(45.2)	2.770	(70.4)	1.250	(31.8)	1.625	(41.3)	28
71	36	1	4.125	(104.8)	1.375	(34.9)	2.113	(53.7)	.875	(22.2)	1.250	(31.8)	20
72	36	1	5.125	(130.2)	1.375	(34.9)	2.113	(53.7)	.875	(22.2)	1.250	(31.8)	20
73	36	1	4.125	(104.8)	1.500	(38.1)	2.363	(60.0)	1.000	(25.4)	1.375	(34.9)	24
74	36	1	5.125	(130.2)	1.500	(38.1)	2.363	(60.0)	1.000	(25.4)	1.375	(34.9)	24
75	36	1	4.125	(104.8)	1.781	(45.2)	2.770	(70.4)	1.250	(31.8)	1.625	(41.3)	28
76	36	1	5.125	(130.2)	1.781	(45.2)	2.770	(70.4)	1.250	(31.8)	1.625	(41.3)	28
77	36	2	5.000	(127.0)	1.830	(46.5)	3.020	(76.7)	1.437	(36.5)	1.875	(47.6)	32
78	36	2	6.000	(152.4)	1.830	(46.5)	3.020	(76.7)	1.437	(36.5)	1.875	(47.6)	32
79	40	1	4.125	(104.8)	1.375	(34.9)	2.113	(53.7)	.875	(22.2)	1.250	(31.8)	20
80	40	1	5.125	(130.2)	1.375	(34.9)	2.113	(53.7)	.875	(22.2)	1.250	(31.8)	20
81	40	1	4.125	(104.8)	1.500	(38.1)	2.363	(60.0)	1.000	(25.4)	1.375	(34.9)	24
82	40	1	5.125	(130.2)	1.500	(38.1)	2.363	(60.0)	1.000	(25.4)	1.375	(34.9)	24
83	40	1	4.125	(104.8)	1.781	(45.2)	2.770	(70.4)	1.250	(31.8)	1.625	(41.3)	28
84	40	1	5.125	(130.2)	1.781	(45.2)	2.770	(70.4)	1.250	(31.8)	1.625	(41.3)	28
85	40	1	4.125	(104.8)	1.830	(46.5)	3.020	(76.7)	1.437	(36.5)	1.875	(47.6)	32
86	40	1	5.125	(130.2)	1.830	(46.5)	3.020	(76.7)	1.437	(36.5)	1.875	(47.6)	32
87	44	1	4.125	(104.8)	1.375	(34.9)	2.113	(53.7)	.875	(22.2)	1.250	(31.8)	20
88	44	1	5.125	(130.2)	1.375	(34.9)	2.113	(53.7)	.875	(22.2)	1.250	(31.8)	20
89	44	1	4.125	(104.8)	1.500	(38.1)	2.363	(60.0)	1.000	(25.4)	1.375	(34.9)	24
90	44	1	5.125	(130.2)	1.500	(38.1)	2.363	(60.0)	1.000	(25.4)	1.375	(34.9)	24
91	44	1	4.125	(104.8)	1.781	(45.2)	2.770	(70.4)	1.250	(31.8)	1.625	(41.3)	28
92	44	1	5.125	(130.2)	1.781	(45.2)	2.770	(70.4)	1.250	(31.8)	1.625	(41.3)	28
93	44	1	4.125	(104.8)	1.830	(46.5)	3.020	(76.7)	1.437	(36.5)	1.875	(47.6)	32
94	44	1	5.125	(130.2)	1.830	(46.5)	3.020	(76.7)	1.437	(36.5)	1.875	(47.6)	32
95	48	1	4.125	(104.8)	1.375	(34.9)	2.113	(53.7)	.875	(22.2)	1.250	(31.8)	20
96	48	1	5.125	(130.2)	1.375	(34.9)	2.113	(53.7)	.875	(22.2)	1.250	(31.8)	20
97	48	1	4.125	(104.8)	1.500	(38.1)	2.363	(60.0)	1.000	(25.4)	1.375	(34.9)	24
98	48	1	5.125	(130.2)	1.500	(38.1)	2.363	(60.0)	1.000	(25.4)	1.375	(34.9)	24
99	48	1	4.125	(104.8)	1.781	(45.2)	2.770	(70.4)	1.250	(31.8)	1.625	(41.3)	28
100	48	1	5.125	(130.2)	1.781	(45.2)	2.770	(70.4)	1.250	(31.8)	1.625	(41.3)	28
101	48	1	4.125	(104.8)	1.830	(46.5)	3.020	(76.7)	1.437	(36.5)	1.875	(47.6)	32
102	48	1	5.125	(130.2)	1.830	(46.5)	3.020	(76.7)	1.437	(36.5)	1.875	(47.6)	32
103	61	1	3.125	(79.4)	1.059	(26.9)	1.551	(39.4)	.500	(12.7)	.750	(19.1)	12
104	61	1	4.125	(104.8)	1.059	(26.9)	1.551	(39.4)	.500	(12.7)	.750	(19.1)	12

Table continued on the next page.

**AS85049/11 and MS3437B
Environmental Backshells**



Environmental
Backshells

TABLE II (Continued)

Dash No.	Shell Size	Style	E		K		L		Cable Range			M85049/42 Ref	
			Max	(Inches)	Ref.	(Inches)	Max	(Inches)	Min	(Inches)	Max		(Inches)
105	61	1	3.125	(79.4)	1.156	(29.4)	1.770	(45.0)	.625	(15.9)	.937	(23.8)	16
106	61	1	4.125	(104.8)	1.156	(29.4)	1.770	(45.0)	.625	(15.9)	.937	(23.8)	16
107	61	2	3.875	(98.4)	1.375	(34.9)	2.113	(53.7)	.875	(22.2)	1.250	(31.8)	20
108	61	2	4.875	(123.8)	1.375	(34.9)	2.113	(53.7)	.875	(22.2)	1.250	(31.8)	20
109	61	2	3.875	(98.4)	1.500	(38.1)	2.363	(60.0)	1.000	(25.4)	1.375	(34.9)	24
110	61	2	4.875	(123.8)	1.500	(38.1)	2.363	(60.0)	1.000	(25.4)	1.375	(34.9)	24
111	12	1	2.125	(54.0)	1.027	(26.1)	1.332	(33.8)	.350	(8.9)	.500	(12.7)	10
112	16	1	2.125	(54.0)	1.027	(26.1)	1.145	(29.1)	.250	(6.4)	.437	(11.1)	6
113	16	1	3.125	(79.4)	1.027	(26.1)	1.145	(29.1)	.250	(6.4)	.437	(11.1)	6
114	12	1	2.125	(54.0)	1.027	(26.1)	.957	(24.3)	.125	(3.2)	.312	(7.9)	4
115	12	1	3.125	(79.4)	1.027	(26.1)	.957	(24.3)	.125	(3.2)	.312	(7.9)	4
116	14	1	2.125	(54.0)	1.027	(26.1)	1.145	(29.1)	.250	(6.4)	.437	(11.1)	6
117	14	1	3.125	(79.4)	1.027	(26.1)	1.145	(29.1)	.250	(6.4)	.437	(11.1)	6
118	16	1	2.125	(54.0)	1.027	(26.1)	1.332	(33.8)	.350	(8.9)	.625	(15.9)	10
119	16	1	3.125	(79.4)	1.027	(26.1)	1.332	(33.8)	.350	(8.9)	.625	(15.9)	10
120	18	1	2.125	(54.0)	1.027	(26.1)	.957	(24.3)	.125	(3.2)	.312	(7.9)	4
121	18	1	3.125	(79.4)	1.027	(26.1)	.957	(24.3)	.125	(3.2)	.312	(7.9)	4
122	18	1	2.125	(54.0)	1.027	(26.1)	1.145	(29.1)	.250	(6.4)	.437	(11.1)	6
123	18	1	3.125	(79.4)	1.027	(26.1)	1.145	(29.1)	.250	(6.4)	.437	(11.1)	6
124	20	1	3.125	(79.4)	1.027	(26.1)	1.145	(29.1)	.250	(6.4)	.437	(11.1)	6
125	20	1	4.125	(104.8)	1.027	(26.1)	1.145	(29.1)	.250	(6.4)	.437	(11.1)	6
126	22	1	3.125	(79.4)	1.027	(26.1)	.957	(24.3)	.125	(3.2)	.312	(7.9)	4
127	22	1	4.125	(104.8)	1.027	(26.1)	.957	(24.3)	.125	(3.2)	.312	(7.9)	4
128	22	1	3.125	(79.4)	1.027	(26.1)	1.145	(29.1)	.250	(6.4)	.437	(11.1)	6
129	22	1	4.125	(104.8)	1.027	(26.1)	1.145	(29.1)	.250	(6.4)	.437	(11.1)	6
130	24	1	3.125	(79.4)	1.027	(26.1)	1.332	(33.8)	.350	(8.9)	.625	(15.9)	10
131	24	1	4.125	(104.8)	1.027	(26.1)	1.332	(33.8)	.350	(8.9)	.625	(15.9)	10
132	36	1	4.125	(104.8)	1.059	(26.9)	1.551	(39.4)	.500	(12.7)	.750	(19.1)	12
133	36	1	5.125	(130.2)	1.059	(26.9)	1.551	(39.4)	.500	(12.7)	.750	(19.1)	12
134	40	1	4.125	(104.8)	1.059	(26.9)	1.551	(39.4)	.500	(12.7)	.750	(19.1)	12
135	40	1	5.125	(130.2)	1.059	(26.9)	1.551	(39.4)	.500	(12.7)	.750	(19.1)	12
136	10	1	2.125	(54.0)	1.027	(26.1)	1.145	(29.1)	.250	(6.4)	.375	(9.5)	6
137	10	1	3.125	(79.4)	1.027	(26.1)	1.145	(29.1)	.250	(6.4)	.375	(9.5)	6
138	12	1	2.125	(54.0)	1.027	(26.1)	1.332	(33.8)	.350	(8.9)	.500	(12.7)	10
139	12	1	3.125	(79.4)	1.027	(26.1)	1.332	(33.8)	.350	(8.9)	.500	(12.7)	10
140	20	1	3.125	(79.4)	1.156	(29.4)	1.770	(45.0)	.625	(15.9)	.904	(23.0)	16
141	20	1	4.125	(104.8)	1.156	(29.4)	1.770	(45.0)	.625	(15.9)	.904	(23.0)	16
142	22	1	3.125	(79.4)	1.375	(34.9)	2.113	(53.7)	.875	(22.2)	1.029	(26.1)	20
143	22	1	4.125	(104.8)	1.375	(34.9)	2.113	(53.7)	.875	(22.2)	1.029	(26.1)	20
144	24	1	3.125	(79.4)	1.375	(34.9)	2.113	(53.7)	.875	(22.2)	1.144	(29.1)	20
145	24	1	4.125	(104.8)	1.375	(34.9)	2.113	(53.7)	.875	(22.2)	1.144	(29.1)	20
146	36	1	4.125	(104.8)	1.830	(46.5)	3.020	(76.7)	1.437	(36.5)	1.840	(46.7)	32
147	36	1	5.125	(130.2)	1.830	(46.5)	3.020	(76.7)	1.437	(36.5)	1.840	(46.7)	32
148	36	1	4.125	(104.8)	1.156	(29.4)	1.770	(45.0)	.625	(15.9)	.937	(23.8)	16
149	36	1	5.125	(130.2)	1.156	(29.4)	1.770	(45.0)	.625	(15.9)	.937	(23.8)	16
150	14	1	2.125	(54.0)	1.027	(26.1)	.957	(24.3)	.125	(3.2)	.312	(7.9)	4
151	14	1	3.125	(79.4)	1.027	(26.1)	.957	(24.3)	.125	(3.2)	.312	(7.9)	4
152	16	1	2.125	(54.0)	1.027	(26.1)	.957	(24.3)	.125	(3.2)	.312	(7.9)	4
153	16	1	3.125	(79.4)	1.027	(26.1)	.957	(24.3)	.125	(3.2)	.312	(7.9)	4
154	44	1	4.125	(104.8)	1.156	(29.4)	1.770	(45.0)	.625	(15.9)	.937	(23.8)	16
155	44	1	5.125	(130.2)	1.156	(29.4)	1.770	(45.0)	.625	(15.9)	.937	(23.8)	16
156	40	1	4.125	(104.8)	1.156	(29.4)	1.770	(45.0)	.625	(15.9)	.937	(23.8)	16
157	40	1	5.125	(130.2)	1.156	(29.4)	1.770	(45.0)	.625	(15.9)	.937	(23.8)	16

If "on time" is a promise
you hope your vendors will keep...

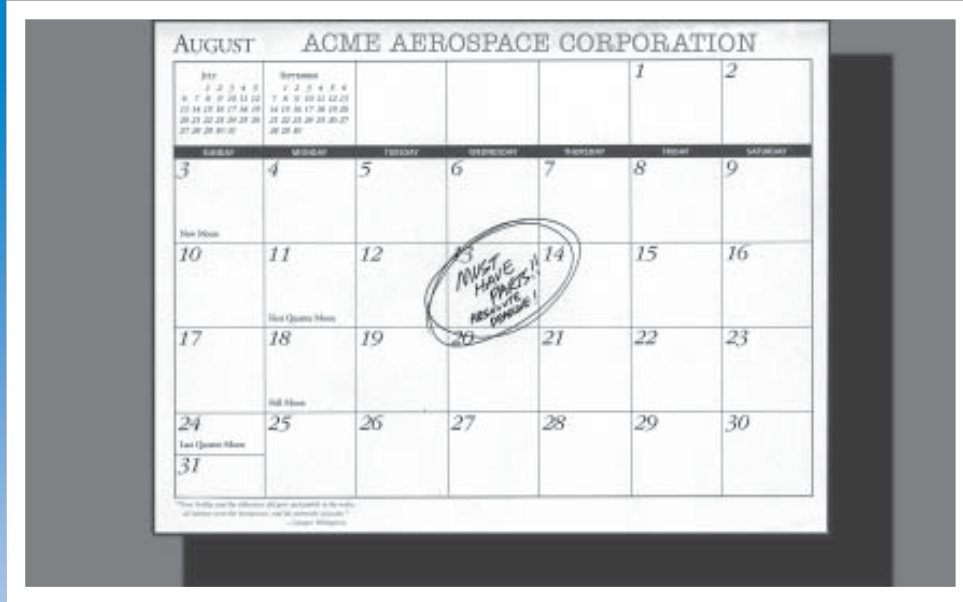

...your best hope is to
place your orders with Glenair.

Most interconnect accessory suppliers quote several months or more to make a backshell. At Glenair, we not only quote the shortest lead times in our industry—generally 2-3 weeks—we also do the best job by far of getting the work out when we say we will. While it's true we can't

promise we'll always make our dates, we're confident we'll be way ahead of whoever's in second place when it comes to on-time delivery. And for those jobs which can't wait even 2-3 weeks, we offer over 35,000 part numbers in stock and ready for same-day shipment.



Commercial and Mil Spec connector accessories

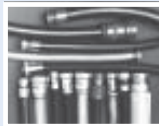

Convoluted tubing and metal-core conduit



Electrical and fiber optic cable assemblies



Composite thermoplastic components



Microminiature connectors and accessories



Backshell assembly and termination tools



1211 Air Way

Glendale, California 91201-2497

Telephone: 818-247-6000 · Facsimilie: 818-500-9912 · EMail: sales@glenair.com

United States · United Kingdom · Germany · France · Nordic · Italy · Spain

www.glenair.com

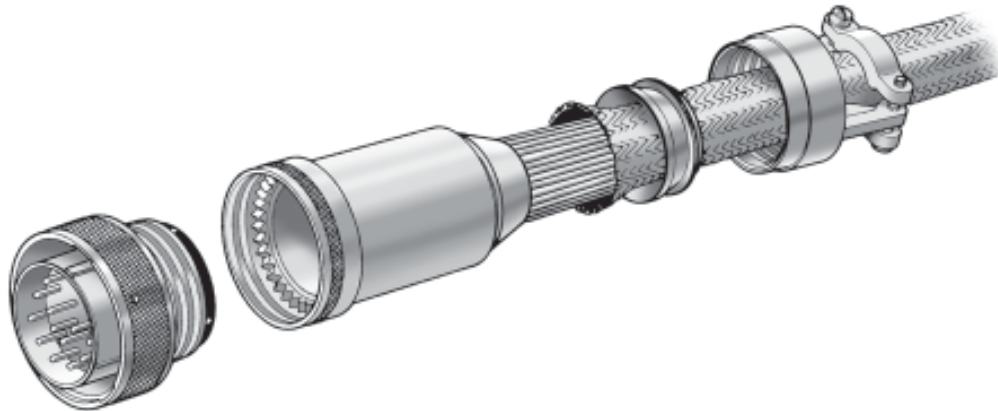

A choice of 360° shield/screen terminations are offered in straight and angled backshells, and include designs to accommodate combinations of individual or overall shields or screens. All designs included in this section provide low dc resistance across the termination area.

Military Specification	Superceeding Part Number	Glenair's Commercial Catalog P/N	Description	Glenair Connector Designator	Page Number
MS3188C	M85049/24	380AA001	90° Backshell	A	38-8
MS3189C	M85049/23	380AB001	45° Backshell	A	38-6
MS3437C	M85049/25	380AS001	Straight Backshell	A	38-10
M38999/7	M85049/36	380FS008	Straight Backshell	F	38-14*
M38999/8	M85049/37	380FD007	90° Backshell	F	38-15*
M81511/14 (C,D)		380JS008	Straight Backshell	J	38-2
AS85049/19		380HS007	Straight Backshell	H	38-5
AS85049/23		380AB001	45° Backshell	A	38-6
AS85049/24		380AA001	90° Backshell	A	38-8
AS85049/25		380AS001	Straight Backshell	A	38-10
AS85049/36		380FS008	Straight Backshell	F	38-14
AS85049/37		380FD007	90° Backshell	F	38-15

* Page Number of Superceeding Part Number
** Consult Factory

Glenair Connector
Designator J

M81511/14-100

Basic Part No. _____ Dash No. _____

MIL-C-81511

Inactive for New Design

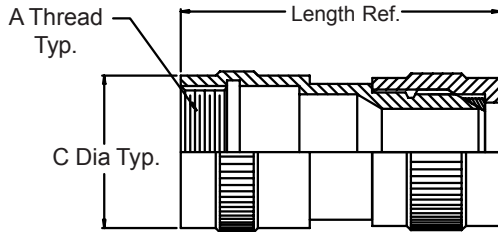

Function "C" Adapter Assembly

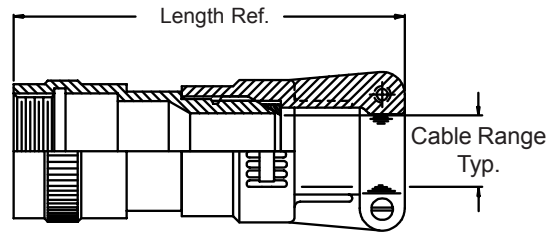

Function "D" Adapter Assembly

TABLE I

Dash No.	Shell Size	Function	A Thread Class 2B	C Dia. Max	Length Ref.	Cable Range	
						Min	Max
057	08	C	.500 - 28 UNEF	.555 (14.1)	1.71 (43.4)	.062 (1.6)	.125 (3.2)
058	08	C	.500 - 28 UNEF	.555 (14.1)	1.71 (43.4)	.125 (3.2)	.250 (6.4)
059	08	D	.500 - 28 UNEF	.555 (14.1)	2.47 (62.7)	.062 (1.6)	.125 (3.2)
060	08	D	.500 - 28 UNEF	.555 (14.1)	2.47 (62.7)	.125 (3.2)	.250 (6.4)
061	08	C	.500 - 28 UNEF	.555 (14.1)	2.21 (56.1)	.062 (1.6)	.125 (3.2)
062	08	C	.500 - 28 UNEF	.555 (14.1)	2.21 (56.1)	.125 (3.2)	.250 (6.4)
063	08	D	.500 - 28 UNEF	.555 (14.1)	2.97 (75.4)	.062 (1.6)	.125 (3.2)
064	08	D	.500 - 28 UNEF	.555 (14.1)	2.97 (75.4)	.125 (3.2)	.250 (6.4)
065	10	C	.625 - 28 UN	.680 (17.3)	1.71 (43.4)	.125 (3.2)	.250 (6.4)
066	10	C	.625 - 28 UN	.680 (17.3)	1.71 (43.4)	.250 (6.4)	.375 (9.5)
067	10	C	.625 - 28 UN	.680 (17.3)	1.71 (43.4)	.375 (9.5)	.500 (12.7)
068	10	D	.625 - 28 UN	.680 (17.3)	2.47 (62.7)	.125 (3.2)	.250 (6.4)
069	10	D	.625 - 28 UN	.680 (17.3)	2.47 (62.7)	.250 (6.4)	.375 (9.5)
070	10	D	.625 - 28 UN	.680 (17.3)	2.47 (62.7)	.375 (9.5)	.500 (12.7)
071	10	C	.625 - 28 UN	.680 (17.3)	2.21 (56.1)	.125 (3.2)	.250 (6.4)
072	10	C	.625 - 28 UN	.680 (17.3)	2.21 (56.1)	.250 (6.4)	.375 (9.5)
073	10	C	.625 - 28 UN	.680 (17.3)	2.21 (56.1)	.375 (9.5)	.500 (12.7)
074	10	D	.625 - 28 UN	.680 (17.3)	2.97 (75.4)	.125 (3.2)	.250 (6.4)
075	10	D	.625 - 28 UN	.680 (17.3)	2.97 (75.4)	.250 (6.4)	.375 (9.5)
076	10	D	.625 - 28 UN	.680 (17.3)	2.97 (75.4)	.375 (9.5)	.500 (12.7)
077	14	C	.875 - 28 UN	.930 (23.6)	1.71 (43.4)	.250 (6.4)	.375 (9.5)
078	14	C	.875 - 28 UN	.930 (23.6)	1.71 (43.4)	.375 (9.5)	.500 (12.7)
079	14	C	.875 - 28 UN	.930 (23.6)	1.71 (43.4)	.500 (12.7)	.625 (15.9)
080	14	D	.875 - 28 UN	.930 (23.6)	2.47 (62.7)	.250 (6.4)	.375 (9.5)
081	14	D	.875 - 28 UN	.930 (23.6)	2.47 (62.7)	.375 (9.5)	.500 (12.7)
082	14	D	.875 - 28 UN	.930 (23.6)	2.47 (62.7)	.500 (12.7)	.625 (15.9)
083	14	C	.875 - 28 UN	.930 (23.6)	2.21 (56.1)	.250 (6.4)	.375 (9.5)
084	14	C	.875 - 28 UN	.930 (23.6)	2.21 (56.1)	.375 (9.5)	.500 (12.7)

Table I Continued on Page 38-3

1. For complete dimensions see applicable Military Specification.
2. Metric dimensions (mm) are indicated in parentheses.
3. For Functions A and B see page 39-6.

M81511/14 Functions C and D
RFI Non-Environmental Backshells



EMI/RFI
Non-Env.
Backshells

TABLE I (Continued From Page 38-2)

Dash No.	Shell Size	Function	A Thread Class 2B	C Dia. Max	Length Ref.	Cable Range	
						Min	Max
085	14	C	.875 - 28 UN	.930 (23.6)	2.21 (56.1)	.500 (12.7)	.625 (15.9)
086	14	D	.875 - 28 UN	.930 (23.6)	2.97 (75.4)	.250 (6.4)	.375 (9.5)
087	14	D	.875 - 28 UN	.930 (23.6)	2.97 (75.4)	.375 (9.5)	.500 (12.7)
088	14	D	.875 - 28 UN	.930 (23.6)	2.97 (75.4)	.500 (12.7)	.625 (15.9)
089	16	C	1.000 - 28 UN	1.056 (26.8)	1.71 (43.4)	.250 (6.4)	.375 (9.5)
090	16	C	1.000 - 28 UN	1.056 (26.8)	1.71 (43.4)	.375 (9.5)	.500 (12.7)
091	16	C	1.000 - 28 UN	1.056 (26.8)	1.71 (43.4)	.500 (12.7)	.625 (15.9)
092	16	D	1.000 - 28 UN	1.056 (26.8)	2.47 (62.7)	.250 (6.4)	.375 (9.5)
093	16	D	1.000 - 28 UN	1.056 (26.8)	2.47 (62.7)	.375 (9.5)	.500 (12.7)
094	16	D	1.000 - 28 UN	1.056 (26.8)	2.47 (62.7)	.500 (12.7)	.625 (15.9)
095	16	C	1.000 - 28 UN	1.056 (26.8)	2.21 (56.1)	.250 (6.4)	.375 (9.5)
096	16	C	1.000 - 28 UN	1.056 (26.8)	2.21 (56.1)	.375 (9.5)	.500 (12.7)
097	16	C	1.000 - 28 UN	1.056 (26.8)	2.21 (56.1)	.500 (12.7)	.625 (15.9)
098	16	D	1.000 - 28 UN	1.056 (26.8)	2.97 (75.4)	.250 (6.4)	.375 (9.5)
099	16	D	1.000 - 28 UN	1.056 (26.8)	2.97 (75.4)	.375 (9.5)	.500 (12.7)
100	16	D	1.000 - 28 UN	1.056 (26.8)	2.97 (75.4)	.500 (12.7)	.625 (15.9)
101	18	C	1.125 - 28 UN	1.180 (30.0)	1.71 (43.4)	.375 (9.5)	.500 (12.7)
102	18	C	1.125 - 28 UN	1.180 (30.0)	1.71 (43.4)	.500 (12.7)	.625 (15.9)
103	18	C	1.125 - 28 UN	1.180 (30.0)	1.71 (43.4)	.625 (15.9)	.750 (19.1)
104	18	D	1.125 - 28 UN	1.180 (30.0)	2.47 (62.7)	.375 (9.5)	.500 (12.7)
105	18	D	1.125 - 28 UN	1.180 (30.0)	2.47 (62.7)	.500 (12.7)	.625 (15.9)
106	18	D	1.125 - 28 UN	1.180 (30.0)	2.47 (62.7)	.625 (15.9)	.750 (19.1)
107	18	C	1.125 - 28 UN	1.180 (30.0)	2.21 (56.1)	.375 (9.5)	.500 (12.7)
108	18	C	1.125 - 28 UN	1.180 (30.0)	2.21 (56.1)	.500 (12.7)	.625 (15.9)
109	18	C	1.125 - 28 UN	1.180 (30.0)	2.21 (56.1)	.625 (15.9)	.750 (19.1)
110	18	D	1.125 - 28 UN	1.180 (30.0)	2.97 (75.4)	.375 (9.5)	.500 (12.7)
111	18	D	1.125 - 28 UN	1.180 (30.0)	2.97 (75.4)	.500 (12.7)	.625 (15.9)
112	18	D	1.125 - 28 UN	1.180 (30.0)	2.97 (75.4)	.625 (15.9)	.750 (19.1)
149	20	C	1.250 - 28 UN	1.305 (33.1)	1.78 (45.2)	.500 (12.7)	.625 (15.9)
150	20	C	1.250 - 28 UN	1.305 (33.1)	1.78 (45.2)	.625 (15.9)	.750 (19.1)
151	20	C	1.250 - 28 UN	1.305 (33.1)	1.78 (45.2)	.750 (19.1)	.875 (22.2)
152	20	D	1.250 - 28 UN	1.305 (33.1)	2.55 (64.8)	.500 (12.7)	.625 (15.9)
153	20	D	1.250 - 28 UN	1.305 (33.1)	2.55 (64.8)	.625 (15.9)	.750 (19.1)
154	20	D	1.250 - 28 UN	1.305 (33.1)	2.55 (64.8)	.750 (19.1)	.875 (22.2)
155	20	C	1.250 - 28 UN	1.305 (33.1)	2.28 (57.9)	.500 (12.7)	.625 (15.9)
156	20	C	1.250 - 28 UN	1.305 (33.1)	2.28 (57.9)	.625 (15.9)	.750 (19.1)
157	20	C	1.250 - 28 UN	1.305 (33.1)	2.28 (57.9)	.750 (19.1)	.875 (22.2)
158	20	D	1.250 - 28 UN	1.305 (33.1)	3.05 (77.5)	.500 (12.7)	.625 (15.9)
159	20	D	1.250 - 28 UN	1.305 (33.1)	3.05 (77.5)	.625 (15.9)	.750 (19.1)
160	20	D	1.250 - 28 UN	1.305 (33.1)	3.05 (77.5)	.750 (19.1)	.875 (22.2)
161	22	C	1.375 - 28 UN	1.430 (36.3)	1.78 (45.2)	.625 (15.9)	.750 (19.1)
162	22	C	1.375 - 28 UN	1.430 (36.3)	1.78 (45.2)	.750 (19.1)	.875 (22.2)
163	22	C	1.375 - 28 UN	1.430 (36.3)	1.78 (45.2)	.875 (22.2)	1.000 (25.4)
164	22	D	1.375 - 28 UN	1.430 (36.3)	2.55 (64.8)	.625 (15.9)	.750 (19.1)
165	22	D	1.375 - 28 UN	1.430 (36.3)	2.55 (64.8)	.750 (19.1)	.875 (22.2)

Table I Continued on Page 38-4

1. For complete dimensions see applicable Military Specification.
2. Metric dimensions (mm) are indicated in parentheses.
3. For Functions A and B see page 39-6.

M81511/14 Functions C and D RFI Non-Environmental Backshells

TABLE I (Continued From Page 38-4)

Dash No.	Shell Size	Function	A Thread Class 2B	C Dia. Max	Length Ref.	Cable Range	
						Min	Max
171	22	D	1.375 - 28 UN	1.430 (36.3)	3.05 (77.5)	.750 (19.1)	.875 (22.2)
172	22	D	1.375 - 28 UN	1.430 (36.3)	3.05 (77.5)	.875 (22.2)	1.000 (25.4)
173	24	C	1.500 - 28 UN	1.555 (39.5)	1.78 (45.2)	.750 (19.1)	.875 (22.2)
174	24	C	1.500 - 28 UN	1.555 (39.5)	1.78 (45.2)	.875 (22.2)	1.000 (25.4)
175	24	C	1.500 - 28 UN	1.555 (39.5)	1.78 (45.2)	1.000 (25.4)	1.125 (28.6)
176	24	D	1.500 - 28 UN	1.555 (39.5)	2.55 (64.8)	.750 (19.1)	.875 (22.2)
177	24	D	1.500 - 28 UN	1.555 (39.5)	2.55 (64.8)	.875 (22.2)	1.000 (25.4)
178	24	D	1.500 - 28 UN	1.555 (39.5)	2.55 (64.8)	1.000 (25.4)	1.125 (28.6)
179	24	C	1.500 - 28 UN	1.555 (39.5)	2.28 (57.9)	.750 (19.1)	.875 (22.2)
180	24	C	1.500 - 28 UN	1.555 (39.5)	2.28 (57.9)	.875 (22.2)	1.000 (25.4)
181	24	C	1.500 - 28 UN	1.555 (39.5)	2.28 (57.9)	1.000 (25.4)	1.125 (28.6)
182	24	D	1.500 - 28 UN	1.555 (39.5)	3.05 (77.5)	.750 (19.1)	.875 (22.2)
183	24	D	1.500 - 28 UN	1.555 (39.5)	3.05 (77.5)	.875 (22.2)	1.000 (25.4)
184	24	D	1.500 - 28 UN	1.555 (39.5)	3.05 (77.5)	1.000 (25.4)	1.125 (28.6)
166	22	D	1.375 - 28 UN	1.430 (36.3)	2.55 (64.8)	.875 (22.2)	1.000 (25.4)
167	22	C	1.375 - 28 UN	1.430 (36.3)	2.28 (57.9)	.625 (15.9)	.750 (19.1)
168	22	C	1.375 - 28 UN	1.430 (36.3)	2.28 (57.9)	.750 (19.1)	.875 (22.2)
169	22	C	1.375 - 28 UN	1.430 (36.3)	2.28 (57.9)	.875 (22.2)	1.000 (25.4)
170	22	D	1.375 - 28 UN	1.430 (36.3)	3.05 (77.5)	.625 (15.9)	.750 (19.1)

1. For complete dimensions see applicable Military Specification.
2. Metric dimensions (mm) are indicated in parentheses.
3. For Functions A and B see page 39-6.

AS85049/19 EMI/RFI Non-Environmental Backshells



EMI/RFI
Non-Env.
Backshells

Glenair Connector
Designator H

MIL-DTL-38999
Series III & IV,
EN3645

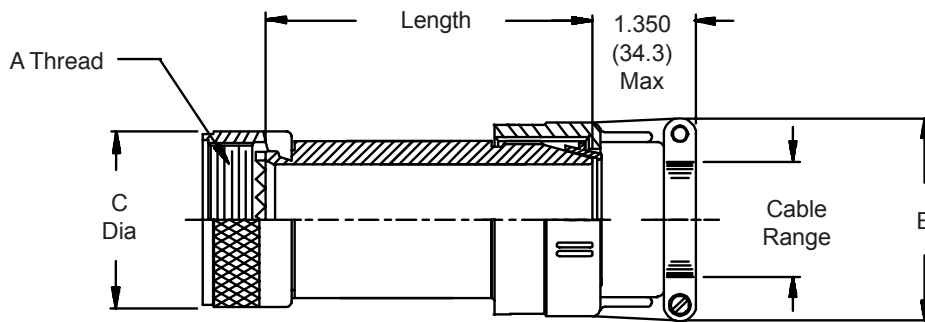
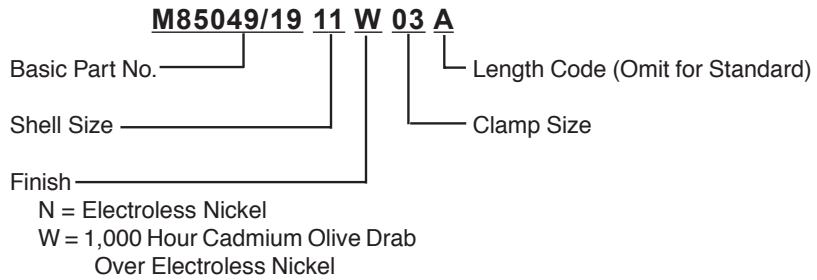

Shell Size	Clamp Size (Table II)		A Thread Class 2B	C Dia Max
	Min	Max		
9	01	02	M12 X 1 - 6H	.75 (19.1)
11	01	03	M15 X 1 - 6H	.85 (21.6)
13	02	04	M18 X 1 - 6H	1.00 (25.4)
15	02	05	M22 X 1 - 6H	1.10 (27.9)
17	02	06	M25 X 1 - 6H	1.25 (31.8)
19	03	07	M28 X 1 - 6H	1.40 (35.6)
21	03	08	M31 X 1 - 6H	1.50 (38.1)
23	03	09	M34 X 1 - 6H	1.65 (41.9)
25	04	10	M37 X 1 - 6H	1.70 (43.2)

Clamp Size	Cable Range		E Max
	Min	Max	
01	.062 (1.6)	.125 (3.2)	.80 (20.3)
02	.125 (3.2)	.250 (6.4)	1.00 (25.4)
03	.250 (6.4)	.375 (9.5)	1.10 (27.9)
04	.312 (7.9)	.500 (12.7)	1.20 (30.5)
05	.437 (11.1)	.625 (15.9)	1.25 (31.8)
06	.562 (14.3)	.750 (19.1)	1.40 (35.6)
07	.687 (17.4)	.875 (22.2)	1.50 (38.1)
08	.812 (20.6)	1.000 (25.4)	1.65 (41.9)
09	.937 (23.8)	1.125 (28.6)	1.75 (44.5)
10	1.062 (27.0)	1.250 (31.8)	1.90 (48.3)

1. For complete dimensions see applicable Military Specification.
2. Metric dimensions (mm) are indicated in parentheses.
3. Cable range is defined as the accommodation range for the wire bundle or cable. Dimensions shown are not intended for inspection criteria.

Length Code	Available Shell Sizes	Length
Std.	9 - 25	1.500 (38.1)
A	9 - 25	2.500 (63.5)
B	15 - 25	3.500 (88.9)
C	21 - 25	4.500 (114.3)



AS85049/23 and MS3189C EMI/RFI Non-Environmental Backshells

Glenair Connector Designator A

MIL-DTL-5015 Series 3400,
MIL-DTL-26482 Series 2,
AS81703 Series 3,
MIL-DTL-83723 Series I &
III, 40M39569, DEF 5326-3,
EN 2997, EN 3646,
ESC 10, ESC 11, LN 29504,
NFC93422 Series HE302,
PAN 6432-1, PAN 6432-2,
PATT 602

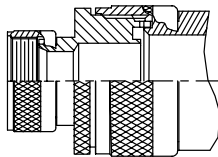

STYLE 2

M85049/23-21 N

Basic Part No. _____
Dash No. _____
Finish and Material
B = Black Cadmium, Stainless Steel
N = Electroless Nickel, Aluminum
S = Passivated Stainless Steel
W = 1,000 Hour Cadmium Olive Drab Over
Electroless Nickel, Aluminum

MS3189C 21 N

Basic Part No. _____
Dash No. _____
Finish (Material is Aluminum)
A = Cadmium Olive Drab over Nickel
C = Cadmium Olive Drab
N = Electroless Nickel

Superceded Part Number

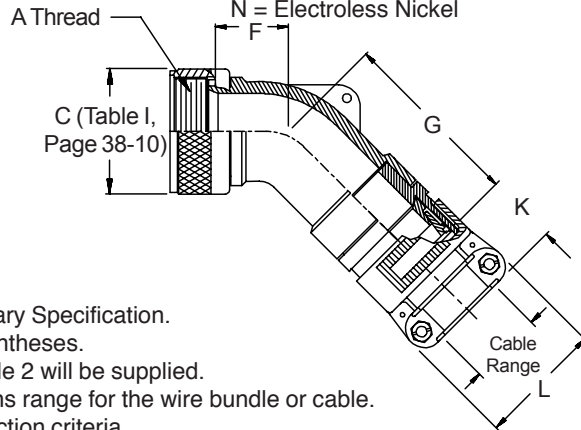

1. For complete dimensions see applicable Military Specification.
 2. Metric dimensions (mm) are indicated in parentheses.
 3. When maximum cable entry is exceeded, Style 2 will be supplied.
 4. Cable range is defined as the accommodations range for the wire bundle or cable.
- Dimensions shown are not intended for inspection criteria.

TABLE II

Dash No.	Shell Size	F		G		K		L		Cable Range		M85049/42 Ref		
		Max	(mm)	Max	(mm)	Ref.	(mm)	Max	(mm)	Min	Max			
1	3	.687	(17.4)	1.915	(48.6)	1.027	(26.1)	.957	(24.3)	.125	(3.2)	.250	(6.4)	4
2	3	1.500	(38.1)	2.035	(51.7)	1.027	(26.1)	1.145	(29.1)	.250	(6.4)	.437	(11.1)	6
3	8	.625	(15.9)	1.307	(33.2)	1.027	(26.1)	.957	(24.3)	.125	(3.2)	.250	(6.4)	4
4	10	.687	(17.4)	1.975	(50.2)	1.027	(26.1)	.957	(24.3)	.125	(3.2)	.312	(7.9)	4
5	10	.687	(17.4)	1.370	(34.8)	1.027	(26.1)	1.145	(29.1)	.250	(6.4)	.375	(9.5)	6
6	12	.750	(19.1)	2.035	(51.7)	1.027	(26.1)	.957	(24.3)	.125	(3.2)	.312	(7.9)	4
7	12	.750	(19.1)	2.035	(51.7)	1.027	(26.1)	1.145	(29.1)	.250	(6.4)	.437	(11.1)	6
8	12	.750	(19.1)	2.035	(51.7)	1.027	(26.1)	1.332	(33.8)	.350	(8.9)	.500	(12.7)	10
9	14	.812	(20.6)	2.125	(54.0)	1.027	(26.1)	1.145	(29.1)	.250	(6.4)	.437	(11.1)	6
10	14	.812	(20.6)	1.780	(45.2)	1.027	(26.1)	1.332	(33.8)	.350	(8.9)	.575	(14.6)	10
11	16	.906	(23.0)	2.235	(56.8)	1.027	(26.1)	1.145	(29.1)	.250	(6.4)	.437	(11.1)	6
12	16	.906	(23.0)	1.875	(47.6)	1.059	(26.9)	1.551	(39.4)	.500	(12.7)	.700	(17.8)	12
13	18	1.093	(27.8)	2.425	(61.6)	1.027	(26.1)	1.332	(33.8)	.350	(8.9)	.625	(15.9)	10
14	18	1.093	(27.8)	2.062	(52.4)	1.156	(29.4)	1.770	(45.0)	.625	(15.9)	.779	(19.8)	16
15	20	1.093	(27.8)	2.425	(61.6)	1.027	(26.1)	1.332	(33.8)	.350	(8.9)	.625	(15.9)	10
16	20	1.093	(27.8)	2.062	(52.4)	1.156	(29.4)	1.770	(45.0)	.625	(15.9)	.904	(23.0)	16
17	22	1.188	(30.2)	2.575	(65.4)	1.059	(26.9)	1.551	(39.4)	.500	(12.7)	.750	(19.1)	12
18	22	1.188	(30.2)	2.218	(56.3)	1.375	(34.9)	2.113	(53.7)	.875	(22.2)	1.029	(26.1)	20
19	24	1.188	(30.2)	2.575	(65.4)	1.059	(26.9)	1.551	(39.4)	.500	(12.7)	.750	(19.1)	12
20	24	1.188	(30.2)	2.218	(56.3)	1.375	(34.9)	2.113	(53.7)	.875	(22.2)	1.144	(29.1)	20
21	28	1.312	(33.3)	2.625	(66.7)	1.156	(33.7)	1.770	(45.0)	.625	(15.9)	.937	(23.8)	16

Table I Continued on Page 38-7

AS85049/23 and MS3189C
EMI/RFI Non-Environmental Backshells



EMI/RFI
Non-Env.
Backshells

TABLE II (Continued From Page 38-6)

Dash No.	Shell Size	F		G		K		L		Cable Range			M85049/42 Ref	
		Max	()	Max	()	Ref.	()	Max	()	Min	()	Max		()
22	28	1.312	(33.3)	2.281	(57.9)	1.500	(38.1)	2.363	(60.0)	1.000	(25.4)	1.375	(34.9)	24
23	32	1.375	(34.9)	2.725	(69.2)	1.156	(29.4)	1.770	(45.0)	.625	(15.9)	.937	(23.8)	16
24	32	1.375	(34.9)	2.725	(69.2)	1.375	(34.9)	2.113	(53.7)	.875	(22.2)	1.250	(31.8)	20
25	32	1.375	(34.9)	2.500	(63.5)	1.781	(45.2)	2.770	(70.4)	1.250	(31.8)	1.625	(41.3)	28
26	36	1.406	(35.7)	2.815	(71.5)	1.156	(29.4)	1.770	(45.0)	.625	(15.9)	.937	(23.8)	16
27	36	1.406	(35.7)	2.815	(71.5)	1.500	(38.1)	2.363	(60.0)	1.000	(25.4)	1.375	(34.9)	24
28	36	1.406	(35.7)	2.469	(62.7)	1.830	(46.5)	3.020	(76.7)	1.437	(36.5)	1.840	(46.7)	32
29	40	2.156	(54.8)	2.815	(71.5)	1.156	(29.4)	1.770	(45.0)	.625	(15.9)	.937	(23.8)	16
30	40	2.156	(54.8)	2.815	(71.5)	1.500	(38.1)	2.363	(60.0)	1.000	(25.4)	1.375	(34.9)	24
31	40	2.156	(54.8)	2.469	(62.7)	1.830	(46.5)	3.020	(76.7)	1.437	(36.5)	1.875	(47.6)	32
32	44	2.156	(54.8)	2.815	(71.5)	1.156	(29.4)	1.770	(45.0)	.625	(15.9)	.937	(23.8)	16
33	44	2.156	(54.8)	2.815	(71.5)	1.500	(38.1)	2.363	(60.0)	1.000	(25.4)	1.375	(34.9)	24
34	44	2.156	(54.8)	2.469	(62.7)	1.830	(46.5)	3.020	(76.7)	1.437	(36.5)	1.875	(47.6)	32
35	48	2.156	(54.8)	2.815	(71.5)	1.156	(29.4)	1.770	(45.0)	.625	(15.9)	.937	(23.8)	16
36	48	2.156	(54.8)	2.815	(71.5)	1.500	(38.1)	2.363	(60.0)	1.000	(25.4)	1.375	(34.9)	24
37	48	2.156	(54.8)	2.469	(62.7)	1.830	(46.5)	3.020	(76.7)	1.437	(36.5)	1.875	(47.6)	32
38	61	1.188	(30.2)	2.575	(65.4)	1.059	(26.9)	1.551	(39.4)	.500	(12.7)	.750	(19.1)	12
39	61	1.188	(30.2)	2.218	(56.3)	1.375	(34.9)	2.113	(53.7)	.875	(22.2)	1.184	(30.1)	20
40	16	.906	(23.0)	2.235	(56.8)	1.027	(26.1)	1.332	(33.8)	.350	(8.9)	.625	(15.9)	10
41	18	1.093	(27.8)	2.425	(61.6)	1.027	(26.1)	.957	(24.3)	.125	(3.2)	.312	(7.9)	4
42	18	1.093	(27.8)	2.425	(61.6)	1.027	(26.1)	1.145	(29.1)	.250	(6.4)	.437	(11.1)	6
43	20	1.093	(27.8)	2.425	(61.6)	1.027	(26.1)	1.145	(29.1)	.250	(6.4)	.437	(11.1)	6
44	22	1.188	(30.2)	2.575	(65.4)	1.027	(26.1)	.957	(24.3)	.125	(3.2)	.312	(7.9)	4
45	22	1.188	(30.2)	2.575	(65.4)	1.027	(26.1)	1.145	(29.1)	.250	(6.4)	.437	(11.1)	6
46	24	1.188	(30.2)	2.575	(65.4)	1.027	(26.1)	1.332	(33.8)	.350	(8.9)	.625	(15.9)	10
47	36	1.406	(35.7)	2.815	(71.5)	1.059	(26.9)	1.551	(39.4)	.500	(12.7)	.750	(19.1)	12
48	40	2.156	(54.8)	2.815	(71.5)	1.059	(26.9)	1.551	(39.4)	.500	(12.7)	.750	(19.1)	12
49*	10	1.500	(38.1)	2.035	(51.7)	1.027	(26.1)	1.145	(29.1)	.250	(6.4)	.437	(11.1)	6
50*	14	1.842	(46.8)	2.425	(61.6)	1.059	(26.9)	1.551	(39.4)	.500	(12.7)	.750	(19.1)	12
51*	16	1.938	(49.2)	2.575	(65.4)	1.156	(29.4)	1.770	(45.0)	.625	(15.9)	.937	(23.8)	16
52	18	1.093	(27.8)	2.425	(61.6)	1.059	(26.9)	1.551	(39.4)	.500	(12.7)	.750	(19.1)	12
53	61	1.188	(30.2)	2.575	(65.4)	1.156	(29.4)	1.770	(45.0)	.625	(15.9)	.937	(23.8)	16
54	20	1.093	(27.8)	2.425	(61.6)	1.059	(26.9)	1.551	(39.4)	.500	(12.7)	.750	(19.1)	12
55*	20	2.061	(52.3)	2.625	(66.7)	1.375	(34.9)	2.113	(53.7)	.875	(22.2)	1.250	(31.8)	20
56	22	1.188	(30.2)	2.575	(65.4)	1.027	(26.1)	1.332	(33.8)	.350	(8.9)	.625	(15.9)	10
57	22	1.188	(30.2)	2.575	(65.4)	1.156	(29.4)	1.770	(45.0)	.625	(15.9)	.937	(23.8)	16
58*	22	2.061	(52.3)	2.625	(66.7)	1.375	(34.9)	2.113	(53.7)	.875	(22.2)	1.250	(31.8)	20
59	24	1.188	(30.2)	2.575	(65.4)	1.156	(29.4)	1.770	(45.0)	.625	(15.9)	.937	(23.8)	16
60	28	1.312	(33.3)	2.625	(66.7)	1.059	(26.9)	1.551	(39.4)	.500	(12.7)	.750	(19.1)	12
61	28	1.312	(33.3)	2.625	(66.7)	1.375	(34.9)	2.113	(53.7)	.875	(22.2)	1.250	(31.8)	20
62	32	1.375	(34.9)	2.725	(69.2)	1.500	(38.1)	2.363	(60.0)	1.000	(25.4)	1.375	(34.9)	24
63	36	1.406	(35.7)	2.815	(71.5)	1.375	(34.9)	2.113	(53.7)	.875	(22.2)	1.250	(31.8)	20
64	36	1.406	(35.7)	2.815	(71.5)	1.781	(45.2)	2.770	(70.4)	1.250	(31.8)	1.625	(41.3)	28
65	40	2.156	(54.8)	2.815	(71.5)	1.375	(34.9)	2.113	(53.7)	.875	(22.2)	1.250	(31.8)	20
66	40	2.156	(54.8)	2.815	(71.5)	1.781	(45.2)	2.770	(70.4)	1.250	(31.8)	1.625	(41.3)	28
67	44	2.156	(54.8)	2.815	(71.5)	1.375	(34.9)	2.113	(53.7)	.875	(22.2)	1.250	(31.8)	20
68	44	2.156	(54.8)	2.815	(71.5)	1.781	(45.2)	2.770	(70.4)	1.250	(31.8)	1.625	(41.3)	28
69	48	2.156	(54.8)	2.815	(71.5)	1.375	(34.9)	2.113	(53.7)	.875	(22.2)	1.250	(31.8)	20
70	48	2.156	(54.8)	2.815	(71.5)	1.781	(45.2)	2.770	(70.4)	1.250	(31.8)	1.625	(41.3)	28
71*	12	1.684	(42.8)	2.236	(56.8)	1.027	(26.1)	1.332	(33.8)	.350	(8.9)	.625	(15.9)	10
72*	18	1.938	(49.2)	2.575	(65.4)	1.156	(29.4)	1.770	(45.0)	.625	(15.9)	.937	(23.8)	16
73*	24	2.061	(52.3)	2.625	(66.7)	1.375	(34.9)	2.113	(53.7)	.875	(22.2)	1.250	(31.8)	20
74	14	.812	(20.6)	2.125	(54.0)	1.027	(26.1)	.957	(24.3)	.125	(3.2)	.312	(7.9)	04
75	16	.906	(23.0)	2.235	(56.8)	1.027	(26.1)	.957	(24.3)	.125	(3.2)	.312	(7.9)	04

AS85049/24 and MS3188C EMI/RFI Non-Environmental Backshells

Glenair Connector Designator A

MIL-DTL-5015 Series 3400,
MIL-DTL-26482 Series 2,
AS81703 Series 3,
MIL-DTL-83723 Series I &
III, 40M39569, DEF 5326-3,
EN 2997, EN 3646,
ESC 10, ESC 11, LN 29504,
NFC93422 Series HE302,
PAN 6432-1, PAN 6432-2,
PATT 602

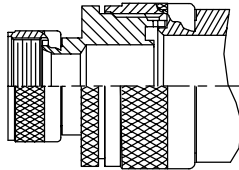

STYLE 2

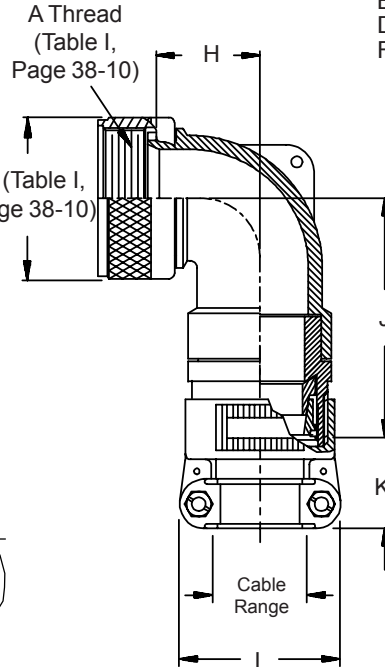

M85049/24-21 N

Basic Part No. _____
Dash No. _____
Finish and Material _____
B = Black Cadmium, Stainless Steel
N = Electroless Nickel, Aluminum
S = Passivated Stainless Steel
W = 1,000 Hour Cadmium Olive Drab
Over Electroless Nickel, Aluminum

Superceded Part Number

MS3188C 21 N

Basic Part No. _____
Dash No. _____
Finish (Material is Aluminum) _____
A = Cadmium Olive Drab over Nickel
C = Cadmium Olive Drab
N = Electroless Nickel

1. For complete dimensions see applicable Military Specification.
2. Metric dimensions (mm) are indicated in parentheses.
3. When maximum cable entry is exceeded, Style 2 will be supplied.

4. Cable range is defined as the accommodations range for the wire bundle or cable.
Dimensions shown are not intended for inspection criteria.

TABLE II

Dash No.	Shell Size	H		J		K		L		Cable Range		M85049/42 Ref		
		Max	(mm)	Max	(mm)	Ref.	(mm)	Max	(mm)	Min	Max			
1	03	.698	(17.7)	1.862	(47.3)	1.027	(26.1)	.957	(24.3)	.125	(3.2)	.250	(6.4)	04
2	03	1.448	(36.8)	1.382	(35.1)	1.027	(26.1)	1.145	(29.1)	.250	(6.4)	.437	(11.1)	04
3	08	.603	(15.3)	1.262	(32.1)	1.027	(26.1)	.957	(24.3)	.125	(3.2)	.250	(6.4)	04
4	10	.698	(17.7)	1.982	(50.3)	1.027	(26.1)	.957	(24.3)	.125	(3.2)	.312	(7.9)	04
5	10	.698	(17.7)	1.382	(35.1)	1.027	(26.1)	1.145	(29.1)	.250	(6.4)	.375	(9.5)	06
6	12	.703	(17.9)	2.002	(50.9)	1.027	(26.1)	.957	(24.3)	.125	(3.2)	.312	(7.9)	04
7	12	.703	(17.9)	2.002	(50.9)	1.027	(26.1)	1.145	(29.1)	.250	(6.4)	.437	(11.1)	06
8	12	.703	(17.9)	1.397	(35.5)	1.027	(26.1)	1.332	(33.8)	.350	(8.9)	.500	(12.7)	10
9	14	.803	(20.4)	2.072	(52.6)	1.027	(26.1)	1.145	(29.1)	.250	(6.4)	.437	(11.1)	06
10	14	.803	(20.4)	1.717	(43.6)	1.027	(26.1)	1.332	(33.8)	.350	(8.9)	.575	(14.6)	10
11	16	.988	(25.1)	2.162	(54.9)	1.027	(26.1)	1.145	(29.1)	.250	(6.4)	.437	(11.1)	06
12	16	.988	(25.1)	1.807	(45.9)	1.059	(26.9)	1.551	(39.4)	.500	(12.7)	.700	(17.8)	12
13	18	1.078	(27.4)	2.332	(59.2)	1.027	(26.1)	1.332	(33.8)	.350	(8.9)	.625	(15.9)	10
14	18	1.078	(27.4)	1.982	(50.3)	1.156	(29.4)	1.770	(45.0)	.625	(15.9)	.779	(19.8)	16
15	20	1.078	(27.4)	2.332	(59.2)	1.027	(26.1)	1.332	(33.8)	.350	(8.9)	.625	(15.9)	10
16	20	1.079	(27.4)	1.982	(50.3)	1.156	(29.4)	1.770	(45.0)	.625	(15.9)	.904	(23.0)	16
17	22	1.228	(31.2)	2.442	(62.0)	1.059	(26.9)	1.551	(39.4)	.500	(12.7)	.750	(19.1)	12
18	22	1.228	(31.2)	2.087	(53.0)	1.375	(34.9)	2.113	(53.7)	.875	(22.2)	1.029	(26.1)	20
19	24	1.228	(31.2)	2.442	(62.0)	1.059	(26.9)	1.551	(39.4)	.500	(12.7)	.750	(19.1)	12
20	24	1.228	(31.2)	2.087	(53.0)	1.375	(34.9)	2.113	(53.7)	.875	(22.2)	1.144	(29.1)	20
21	28	1.328	(33.7)	2.612	(66.3)	1.156	(29.4)	1.770	(45.0)	.625	(15.9)	.937	(23.8)	16

Table I Continued on Page 38-9

**AS85049/24 and MS3188C
EMI/RFI Non-Environmental Backshells**



**EMI/RFI
Non-Env.
Backshells**

TABLE II (Continued From Page 38-8)

Dash No.	Shell Size	H		J		K		L		Cable Range			M85049/42 Ref	
		Max	()	Max	()	Ref.	()	Max	()	Min	()	Max		()
22	28	1.328	(33.7)	2.257	(57.3)	1.500	(38.1)	2.363	(60.0)	1.000	(25.4)	1.375	(34.9)	24
23	32	1.678	(42.6)	2.862	(72.7)	1.156	(29.4)	1.770	(45.0)	.625	(15.9)	.937	(23.8)	16
24	32	1.678	(42.6)	2.862	(72.7)	1.375	(34.9)	2.113	(53.7)	.875	(22.2)	1.250	(31.8)	20
25	32	1.678	(42.6)	2.507	(63.7)	1.781	(45.2)	2.770	(70.4)	1.250	(31.8)	1.625	(41.3)	28
26	36	1.878	(47.7)	2.832	(71.9)	1.156	(29.4)	1.770	(45.0)	.625	(15.9)	.937	(23.8)	16
27	36	1.878	(47.7)	2.832	(71.9)	1.500	(38.1)	2.363	(60.0)	1.000	(25.4)	1.375	(34.9)	24
28	36	1.878	(47.7)	2.477	(62.9)	1.830	(46.5)	3.020	(76.7)	1.437	(36.5)	1.840	(46.7)	32
29	40	2.628	(66.8)	2.832	(71.9)	1.156	(29.4)	1.770	(45.0)	.625	(15.9)	.937	(23.8)	16
30	40	2.628	(66.8)	2.832	(71.9)	1.500	(38.1)	2.363	(60.0)	1.000	(25.4)	1.375	(34.9)	24
31	40	2.628	(66.8)	2.477	(62.9)	1.830	(46.5)	3.020	(76.7)	1.437	(36.5)	1.875	(47.6)	32
32	44	2.628	(66.8)	2.832	(71.9)	1.156	(29.4)	1.770	(45.0)	.625	(15.9)	.937	(23.8)	16
33	44	2.628	(66.8)	2.832	(71.9)	1.500	(38.1)	2.363	(60.0)	1.000	(25.4)	1.375	(34.9)	24
34	44	2.628	(66.8)	2.477	(62.9)	1.830	(46.5)	3.020	(76.7)	1.437	(36.5)	1.875	(47.6)	32
35	48	2.628	(66.8)	2.832	(71.9)	1.156	(29.4)	1.770	(45.0)	.625	(15.9)	.937	(23.8)	16
36	48	2.628	(66.8)	2.832	(71.9)	1.500	(38.1)	2.363	(60.0)	1.000	(25.4)	1.375	(34.9)	24
37	48	2.628	(66.8)	2.477	(62.9)	1.830	(46.5)	3.020	(76.7)	1.437	(36.5)	1.875	(47.6)	32
38	61	1.228	(31.2)	2.442	(62.0)	1.059	(26.9)	1.551	(39.4)	.500	(12.7)	.750	(19.1)	12
39	61	1.228	(31.2)	2.087	(53.0)	1.375	(34.9)	2.113	(53.7)	.875	(22.2)	1.184	(30.1)	20
40	16	.988	(25.1)	2.162	(54.9)	1.027	(26.1)	1.332	(33.8)	.350	(8.9)	.625	(15.9)	10
41	18	1.078	(27.4)	2.332	(59.2)	1.027	(26.1)	.957	(24.3)	.125	(3.2)	.312	(7.9)	04
42	18	1.078	(27.4)	2.332	(59.2)	1.027	(26.1)	1.145	(29.1)	.250	(6.4)	.437	(11.1)	06
43	20	1.078	(27.4)	2.332	(59.2)	1.027	(26.1)	1.145	(29.1)	.250	(6.4)	.437	(11.1)	06
44	22	1.228	(31.2)	2.442	(62.0)	1.027	(26.1)	.957	(24.3)	.125	(3.2)	.312	(7.9)	04
45	22	1.228	(31.2)	2.442	(62.0)	1.027	(26.1)	1.145	(29.1)	.250	(6.4)	.437	(11.1)	06
46	24	1.228	(31.2)	2.442	(62.0)	1.027	(26.1)	1.332	(33.8)	.350	(8.9)	.625	(15.9)	10
47	36	1.878	(47.7)	2.832	(71.9)	1.059	(26.9)	1.551	(39.4)	.500	(12.7)	.750	(19.1)	12
48	40	1.878	(47.7)	2.832	(71.9)	1.059	(26.9)	1.551	(39.4)	.500	(12.7)	.750	(19.1)	12
49*	10	1.453	(36.9)	2.002	(50.9)	1.027	(26.1)	1.145	(29.1)	.250	(6.4)	.437	(11.1)	06
50*	14	1.828	(46.4)	2.334	(59.3)	1.059	(26.9)	1.551	(39.4)	.500	(12.7)	.750	(19.1)	12
51*	16	1.978	(50.2)	2.442	(62.0)	1.156	(29.4)	1.770	(45.0)	.625	(15.9)	.937	(23.8)	16
52	18	1.078	(27.4)	2.332	(59.2)	1.059	(26.9)	1.551	(39.4)	.500	(12.7)	.750	(19.1)	12
53	61	1.228	(31.2)	2.087	(53.0)	1.156	(29.4)	1.770	(45.0)	.625	(15.9)	.937	(23.8)	16
54	20	1.078	(27.4)	2.332	(59.2)	1.059	(26.9)	1.551	(39.4)	.500	(12.7)	.750	(19.1)	12
55*	20	2.078	(52.8)	2.612	(66.3)	1.375	(34.9)	2.113	(53.7)	.875	(22.2)	1.250	(31.8)	20
56	22	1.228	(31.2)	2.442	(62.0)	1.027	(26.1)	1.332	(33.8)	.350	(8.9)	.625	(15.9)	10
57	22	1.228	(31.2)	2.442	(62.0)	1.156	(29.4)	1.770	(45.0)	.625	(15.9)	.937	(23.8)	16
58*	22	2.078	(52.8)	2.612	(66.3)	1.375	(34.9)	2.113	(53.7)	.875	(22.2)	1.250	(31.8)	20
59	24	1.228	(31.2)	2.442	(62.0)	1.156	(29.4)	1.770	(45.0)	.625	(15.9)	.937	(23.8)	16
60	28	1.328	(33.7)	2.612	(66.3)	1.059	(26.9)	1.551	(39.4)	.500	(12.7)	.750	(19.1)	12
61	28	1.328	(33.7)	2.612	(66.3)	1.375	(34.9)	2.113	(53.7)	.875	(22.2)	1.250	(31.8)	20
62	32	1.678	(42.6)	2.862	(72.7)	1.500	(38.1)	2.363	(60.0)	1.000	(25.4)	1.375	(34.9)	24
63	36	1.878	(47.7)	2.832	(71.9)	1.375	(34.9)	2.113	(53.7)	.875	(22.2)	1.250	(31.8)	20
64	36	1.878	(47.7)	2.832	(71.9)	1.781	(45.2)	2.770	(70.4)	1.250	(31.8)	1.625	(41.3)	28
65	40	2.628	(66.8)	2.832	(71.9)	1.375	(34.9)	2.113	(53.7)	.875	(22.2)	1.250	(31.8)	20
66	40	2.628	(66.8)	2.832	(71.9)	1.375	(34.9)	2.113	(53.7)	.875	(22.2)	1.250	(31.8)	28
67	44	2.628	(66.8)	2.832	(71.9)	1.375	(34.9)	2.113	(53.7)	.875	(22.2)	1.250	(31.8)	20
68	44	2.628	(66.8)	2.832	(71.9)	1.781	(45.2)	2.770	(70.4)	1.250	(31.8)	1.625	(41.3)	28
69	48	2.628	(66.8)	2.832	(71.9)	1.375	(34.9)	2.113	(53.7)	.875	(22.2)	1.250	(31.8)	20
70	48	2.628	(66.8)	2.832	(71.9)	1.781	(45.2)	2.770	(70.4)	1.250	(31.8)	1.625	(41.3)	28
71*	12	1.748	(44.4)	2.162	(54.9)	1.027	(26.1)	1.332	(33.8)	.350	(8.9)	.625	(15.9)	10
72*	18	1.988	(50.5)	2.442	(62.0)	1.156	(29.4)	1.770	(45.0)	.625	(15.9)	.937	(23.8)	16
73*	24	2.088	(53.0)	2.612	(66.3)	1.375	(34.9)	2.116	(53.7)	.875	(22.2)	1.250	(31.8)	20
74	14	.803	(20.4)	2.072	(52.6)	1.027	(26.1)	.957	(24.3)	.125	(3.2)	.312	(7.9)	04
75	16	.988	(25.1)	2.162	(54.9)	1.027	(26.1)	.957	(24.3)	.125	(3.2)	.312	(7.9)	04

© 2005 Glenair, Inc.

* Denotes Style 2

CAGE Code 06324

Printed in U.S.A.

AS85049/25 and MS3437C EMI/RFI Non-Environmental Backshells

Glenair Connector Designator A

MIL-DTL-5015 Series 3400,
MIL-DTL-26482 Series 2,
AS81703 Series 3,
MIL-DTL-83723 Series I &
III, 40M39569, DEF 5326-3,
EN 2997, EN 3646,
ESC 10, ESC 11, LN 29504,
NFC93422 Series HE302,
PAN 6432-1, PAN 6432-2,
PATT 602

M85049/25-21 N

Basic Part No. _____
Dash No. (Table II) _____

Finish and Material
B = Black Cadmium, Stainless Steel
N = Electroless Nickel, Aluminum
S = Passivated Stainless Steel
W = 1,000 Hour Cadmium Olive Drab
Over Electroless Nickel, Aluminum

MS3437C 21 N

Basic Part No. _____
Dash No. (Table II) _____

Superceded Part Number
Finish
A = Cadmium Olive Drab over Nickel
C = Cadmium Olive Drab
N = Electroless Nickel

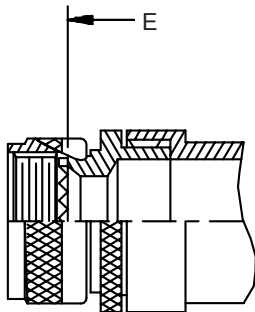

STYLE 2

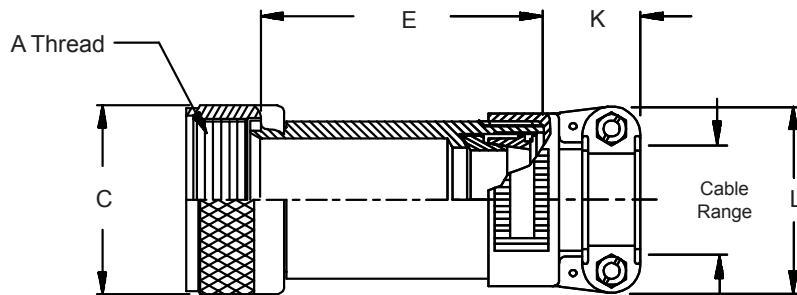

STYLE 1

TABLE I

Shell Size	A Thread Class 2B	C Dia Max
03	.562 - 24 UNEF	.77 (19.6)
08	.500 - 20 UNF	.65 (16.5)
10	.625 - 24 UNEF	.77 (19.6)
12	.750 - 20 UNEF	.40 (10.2)
14	.875 - 20 UNEF	1.02 (25.9)
16	1.000 - 20 UNEF	1.21 (30.7)
18	1.062 - 18 UNEF	1.23 (31.2)
20	1.188 - 18 UNEF	1.36 (34.5)
22	1.313 - 18 UNEF	1.48 (37.6)
24	1.438 - 18 UNEF	1.73 (43.9)
28	1.750 - 18 UNS	1.97 (50.0)
32	2.000 - 18 UNS	2.22 (56.4)
36	2.250 - 16 UN	2.47 (62.7)
40	2.500 - 16 UN	2.72 (69.1)
44	2.750 - 16 UN	2.97 (75.4)
48	3.000 - 16 UN	3.22 (81.8)
61	1.500 - 18 UNEF	1.67 (42.4)

1. For complete dimensions see applicable Military Specification.
2. Metric dimensions (mm) are indicated in parentheses.
3. When maximum cable entry is exceeded, Style 2 will be supplied.
4. Cable range is defined as the accommodations range for the wire bundle or cable. Dimensions shown are not intended for inspection criteria.

**AS85049/25 and MS3437C
EMI/RFI Non-Environmental Backshells**



EMI/RFI
Non-Env.
Backshells

TABLE II

Dash No.	Shell Size	Style	E		K		L		Cable Range			M85049/42	
			Max	()	Ref.	()	Max	()	Min	()	Max	()	Ref
01	03	1	2.062	(52.4)	1.027	(26.1)	.957	(24.3)	.125	(3.2)	.250	(6.4)	4
02	03	1	3.063	(77.8)	1.027	(26.1)	.957	(24.3)	.125	(3.2)	.250	(6.4)	4
03	03	2	2.812	(71.4)	1.027	(26.1)	1.145	(29.1)	.250	(6.4)	.437	(11.1)	6
04	03	2	3.812	(96.8)	1.027	(26.1)	1.145	(29.1)	.250	(6.4)	.437	(11.1)	6
05	08	1	2.062	(52.4)	1.027	(26.1)	.957	(24.3)	.125	(3.2)	.250	(6.4)	4
06	08	1	3.062	(77.8)	1.027	(26.1)	.957	(24.3)	.125	(3.2)	.250	(6.4)	4
07	08	2	2.812	(71.4)	1.027	(26.1)	1.145	(29.1)	.250	(6.4)	.437	(11.1)	6
08	08	2	3.812	(96.8)	1.027	(26.1)	1.145	(29.1)	.250	(6.4)	.437	(11.1)	6
09	10	1	2.062	(52.4)	1.027	(26.1)	.957	(24.3)	.125	(3.2)	.312	(7.9)	4
10	10	1	3.062	(77.8)	1.027	(26.1)	.957	(24.3)	.125	(3.2)	.312	(7.9)	4
11	10	2	2.812	(71.4)	1.027	(26.1)	1.145	(29.1)	.250	(6.4)	.437	(11.1)	6
12	10	2	3.812	(96.8)	1.027	(26.1)	1.145	(29.1)	.250	(6.4)	.437	(11.1)	6
13	12	1	2.062	(52.4)	1.027	(26.1)	1.145	(29.1)	.250	(6.4)	.437	(11.1)	6
14	12	1	3.062	(77.8)	1.027	(26.1)	1.145	(29.1)	.250	(6.4)	.437	(11.1)	6
15	12	2	2.812	(71.4)	1.027	(26.1)	1.332	(33.8)	.350	(8.9)	.625	(15.9)	10
16	12	2	3.812	(96.8)	1.027	(26.1)	1.332	(33.8)	.350	(8.9)	.625	(15.9)	10
17	14	1	2.062	(52.4)	1.027	(26.1)	1.332	(33.8)	.350	(8.9)	.575	(14.6)	10
18	14	1	3.062	(77.8)	1.027	(26.1)	1.332	(33.8)	.350	(8.9)	.575	(14.6)	10
19	14	2	2.812	(71.4)	1.059	(26.9)	1.551	(39.4)	.500	(12.7)	.750	(19.1)	12
20	14	2	3.812	(96.8)	1.059	(26.9)	1.551	(39.4)	.500	(12.7)	.750	(19.1)	12
21	16	1	2.062	(52.4)	1.059	(26.9)	1.551	(39.4)	.500	(12.7)	.700	(17.8)	12
22	16	1	3.062	(77.8)	1.059	(26.9)	1.551	(39.4)	.500	(12.7)	.700	(17.8)	12
23	16	2	2.812	(71.4)	1.156	(29.4)	1.770	(45.0)	.625	(15.9)	.937	(23.8)	16
24	16	2	3.812	(96.8)	1.156	(29.4)	1.770	(45.0)	.625	(15.9)	.937	(23.8)	16
25	18	1	2.062	(52.4)	1.027	(26.1)	1.332	(33.8)	.350	(8.9)	.625	(15.9)	10
26	18	1	3.062	(77.8)	1.027	(26.1)	1.332	(33.8)	.350	(8.9)	.625	(15.9)	10
27	18	1	2.062	(52.4)	1.059	(26.9)	1.551	(39.4)	.500	(12.7)	.750	(19.1)	12
28	18	1	3.062	(77.8)	1.059	(26.9)	1.551	(39.4)	.500	(12.7)	.750	(19.1)	12
29	18	2	2.812	(71.4)	1.156	(29.4)	1.770	(45.0)	.625	(15.9)	.937	(23.8)	16
30	18	2	3.812	(96.8)	1.156	(29.4)	1.770	(45.0)	.625	(15.9)	.937	(23.8)	16
31	20	1	3.062	(77.8)	1.027	(26.1)	1.332	(33.8)	.350	(8.9)	.625	(15.9)	10
32	20	1	4.062	(103.2)	1.027	(26.1)	1.332	(33.8)	.350	(8.9)	.625	(15.9)	10
33	20	1	3.062	(77.8)	1.059	(26.9)	1.551	(39.4)	.500	(12.7)	.750	(19.1)	12
34	20	1	4.062	(103.2)	1.059	(26.9)	1.551	(39.4)	.500	(12.7)	.750	(19.1)	12
35	20	2	3.812	(96.8)	1.156	(29.4)	1.770	(45.0)	.625	(15.9)	.937	(23.8)	16
36	20	2	4.812	(122.2)	1.156	(29.4)	1.770	(45.0)	.625	(15.9)	.937	(23.8)	16
37	20	2	3.812	(96.8)	1.375	(34.9)	2.113	(53.7)	.875	(22.2)	1.250	(31.8)	20
38	20	2	4.812	(122.2)	1.375	(34.9)	2.113	(53.7)	.875	(22.2)	1.250	(31.8)	20
39	22	1	3.062	(77.8)	1.027	(26.1)	1.332	(33.8)	.350	(8.9)	.625	(15.9)	10
40	22	1	4.062	(103.2)	1.027	(26.1)	1.332	(33.8)	.350	(8.9)	.625	(15.9)	10
41	22	1	3.062	(77.8)	1.059	(26.9)	1.551	(39.4)	.500	(12.7)	.750	(19.1)	12
42	22	1	4.062	(103.2)	1.059	(26.9)	1.551	(39.4)	.500	(12.7)	.750	(19.1)	12
43	22	1	3.062	(77.8)	1.156	(29.4)	1.770	(45.0)	.625	(15.9)	.937	(23.8)	16
44	22	1	4.062	(103.2)	1.156	(29.4)	1.770	(45.0)	.625	(15.9)	.937	(23.8)	16
45	22	2	3.812	(96.8)	1.375	(34.9)	2.113	(53.7)	.875	(22.2)	1.250	(31.8)	20
46	22	2	4.812	(122.2)	1.375	(34.9)	2.113	(53.7)	.875	(22.2)	1.250	(31.8)	20
47	24	1	3.062	(77.8)	1.059	(26.9)	1.551	(39.4)	.500	(12.7)	.750	(19.1)	12
48	24	1	4.062	(103.2)	1.059	(26.9)	1.551	(39.4)	.500	(12.7)	.750	(19.1)	12
49	24	1	3.062	(77.8)	1.156	(29.4)	1.770	(45.0)	.625	(15.9)	.812	(20.6)	16
50	24	1	4.062	(103.2)	1.156	(29.4)	1.770	(45.0)	.625	(15.9)	.812	(20.6)	16
51	24	1	3.062	(77.8)	1.156	(29.4)	1.770	(45.0)	.625	(15.9)	.937	(23.8)	16
52	24	1	4.062	(103.2)	1.156	(29.4)	1.770	(45.0)	.625	(15.9)	.937	(23.8)	16

Table I Continued on Page 38-12



AS85049/25 and MS3437C
EMI/RFI Non-Environmental Backshells

TABLE II (Continued From Page 38-11)

Dash No.	Shell Size	Style	E		K		L		Cable Range		M85049/42 Ref		
			Max		Ref.		Max		Min	Max			
53	24	2	3.812	(96.8)	1.375	(34.9)	2.113	(53.7)	.875	(22.2)	1.250	(31.8)	20
54	24	2	4.812	(122.2)	1.375	(34.9)	2.113	(53.7)	.875	(22.2)	1.250	(31.8)	20
55	28	1	3.062	(77.8)	1.059	(26.9)	1.551	(39.4)	.500	(12.7)	.750	(19.1)	12
56	28	1	4.062	(103.2)	1.059	(26.9)	1.551	(39.4)	.500	(12.7)	.750	(19.1)	12
57	28	1	3.062	(77.8)	1.156	(29.4)	1.770	(45.0)	.625	(15.9)	.937	(23.8)	16
58	28	1	4.062	(103.2)	1.156	(29.4)	1.770	(45.0)	.625	(15.9)	.937	(23.8)	16
59	28	1	3.062	(77.8)	1.375	(34.9)	2.113	(53.7)	.875	(22.2)	1.250	(31.8)	20
60	28	1	4.062	(103.2)	1.375	(34.9)	2.113	(53.7)	.875	(22.2)	1.250	(31.8)	20
61	28	1	3.062	(77.8)	1.500	(38.1)	2.363	(60.0)	1.000	(25.4)	1.375	(34.9)	24
62	28	1	4.062	(103.2)	1.500	(38.1)	2.363	(60.0)	1.000	(25.4)	1.375	(34.9)	24
63	32	1	3.062	(77.8)	1.156	(29.4)	1.770	(45.0)	.625	(15.9)	.937	(23.8)	16
64	32	1	4.062	(103.2)	1.156	(29.4)	1.770	(45.0)	.625	(15.9)	.937	(23.8)	16
65	32	1	3.062	(77.8)	1.375	(34.9)	2.113	(53.7)	.875	(22.2)	1.250	(31.8)	20
66	32	1	4.062	(103.2)	1.375	(34.9)	2.113	(53.7)	.875	(22.2)	1.250	(31.8)	20
67	32	1	3.062	(77.8)	1.500	(38.1)	2.363	(60.0)	1.000	(25.4)	1.375	(34.9)	24
68	32	1	4.062	(103.2)	1.500	(38.1)	2.363	(60.0)	1.000	(25.4)	1.375	(34.9)	24
69	32	1	3.062	(77.8)	1.781	(45.2)	2.770	(70.4)	1.250	(31.8)	1.625	(41.3)	28
70	32	1	4.062	(103.2)	1.781	(45.2)	2.770	(70.4)	1.250	(31.8)	1.625	(41.3)	28
71	36	1	4.062	(103.2)	1.375	(34.9)	2.113	(53.7)	.875	(22.2)	1.250	(31.8)	20
72	36	1	5.062	(128.6)	1.375	(34.9)	2.113	(53.7)	.875	(22.2)	1.250	(31.8)	20
73	36	1	4.062	(103.2)	1.500	(38.1)	2.363	(60.0)	1.000	(25.4)	1.375	(34.9)	24
74	36	1	5.062	(128.6)	1.500	(38.1)	2.363	(60.0)	1.000	(25.4)	1.375	(34.9)	24
75	36	1	4.062	(103.2)	1.781	(45.2)	2.770	(70.4)	1.250	(31.8)	1.625	(41.3)	28
76	36	1	5.062	(128.6)	1.781	(45.2)	2.770	(70.4)	1.250	(31.8)	1.625	(41.3)	28
77	36	2	4.942	(125.5)	1.830	(46.5)	3.020	(76.7)	1.437	(36.5)	1.875	(47.6)	32
78	36	2	5.942	(150.9)	1.830	(46.5)	3.020	(76.7)	1.437	(36.5)	1.875	(47.6)	32
79	40	1	4.062	(103.2)	1.375	(34.9)	2.113	(53.7)	.875	(22.2)	1.250	(31.8)	20
80	40	1	5.062	(128.6)	1.375	(34.9)	2.113	(53.7)	.875	(22.2)	1.250	(31.8)	20
81	40	1	4.062	(103.2)	1.500	(38.1)	2.363	(60.0)	1.000	(25.4)	1.375	(34.9)	24
82	40	1	5.062	(128.6)	1.500	(38.1)	2.363	(60.0)	1.000	(25.4)	1.375	(34.9)	24
83	40	1	4.062	(103.2)	1.781	(45.2)	2.770	(70.4)	1.250	(31.8)	1.625	(41.3)	28
84	40	1	5.062	(128.6)	1.781	(45.2)	2.770	(70.4)	1.250	(31.8)	1.625	(41.3)	28
85	40	1	4.062	(103.2)	1.830	(46.5)	3.020	(76.7)	1.437	(36.5)	1.875	(47.6)	32
86	40	1	5.062	(128.6)	1.830	(46.5)	3.020	(76.7)	1.437	(36.5)	1.875	(47.6)	32
87	44	1	4.062	(103.2)	1.375	(34.9)	2.113	(53.7)	.875	(22.2)	1.250	(31.8)	20
88	44	1	5.062	(128.6)	1.375	(34.9)	2.113	(53.7)	.875	(22.2)	1.250	(31.8)	20
89	44	1	4.062	(103.2)	1.500	(38.1)	2.363	(60.0)	1.000	(25.4)	1.375	(34.9)	24
90	44	1	5.062	(128.6)	1.500	(38.1)	2.363	(60.0)	1.000	(25.4)	1.375	(34.9)	24
91	44	1	4.062	(103.2)	1.781	(45.2)	2.770	(70.4)	1.250	(31.8)	1.625	(41.3)	28
92	44	1	5.062	(128.6)	1.781	(45.2)	2.770	(70.4)	1.250	(31.8)	1.625	(41.3)	28
93	44	1	4.062	(103.2)	1.830	(46.5)	3.020	(76.7)	1.437	(36.5)	1.875	(47.6)	32
94	44	1	5.062	(128.6)	1.830	(46.5)	3.020	(76.7)	1.437	(36.5)	1.875	(47.6)	32
95	48	1	4.062	(103.2)	1.375	(34.9)	2.113	(53.7)	.875	(22.2)	1.250	(31.8)	20
96	48	1	5.062	(128.6)	1.375	(34.9)	2.113	(53.7)	.875	(22.2)	1.250	(31.8)	20
97	48	1	4.062	(103.2)	1.500	(38.1)	2.363	(60.0)	1.000	(25.4)	1.375	(34.9)	24
98	48	1	5.062	(128.6)	1.500	(38.1)	2.363	(60.0)	1.000	(25.4)	1.375	(34.9)	24
99	48	1	4.062	(103.2)	1.781	(45.2)	2.770	(70.4)	1.250	(31.8)	1.625	(41.3)	28
100	48	1	5.062	(128.6)	1.781	(45.2)	2.770	(70.4)	1.250	(31.8)	1.625	(41.3)	28
101	48	1	4.062	(103.2)	1.830	(46.5)	3.020	(76.7)	1.437	(36.5)	1.875	(47.6)	32
102	48	1	5.062	(128.6)	1.830	(46.5)	3.020	(76.7)	1.437	(36.5)	1.875	(47.6)	32
103	61	1	3.062	(77.8)	1.059	(26.9)	1.551	(39.4)	.500	(12.7)	.750	(19.1)	12
104	61	1	4.062	(103.2)	1.059	(26.9)	1.551	(39.4)	.500	(12.7)	.750	(19.1)	12

Table I Continued on Page 38-13

AS85049/25 and MS3437C
EMI/RFI Non-Environmental Backshells



EMI/RFI
Non-Env.
Backshells

TABLE II (Continued FROM Page 38-12)

Dash No.	Shell Size	Style	E		K		L		Cable Range			M85049/42 Ref	
			Max	()	Ref.	()	Max	()	Min	Max	()		
105	61	1	3.062	(77.8)	1.156	(29.4)	1.770	(45.0)	.625	(15.9)	.937	(23.8)	16
106	61	1	4.062	(103.2)	1.156	(29.4)	1.770	(45.0)	.625	(15.9)	.937	(23.8)	16
107	61	2	3.812	(96.8)	1.375	(34.9)	2.113	(53.7)	.875	(22.2)	1.250	(31.8)	20
108	61	2	4.812	(122.2)	1.375	(34.9)	2.113	(53.7)	.875	(22.2)	1.250	(31.8)	20
109	61	2	3.812	(96.8)	1.500	(38.1)	2.363	(60.0)	1.000	(25.4)	1.375	(34.9)	24
110	61	2	4.812	(122.2)	1.500	(38.1)	2.363	(60.0)	1.000	(25.4)	1.375	(34.9)	24
111	12	1	2.062	(52.4)	1.027	(26.1)	1.332	(33.8)	.350	(8.9)	.500	(12.7)	10
112	16	1	2.062	(52.4)	1.027	(26.1)	1.145	(29.1)	.250	(6.4)	.437	(11.1)	06
113	16	1	3.062	(77.8)	1.027	(26.1)	1.145	(29.1)	.250	(6.4)	.437	(11.1)	06
114	12	1	2.062	(52.4)	1.027	(26.1)	.957	(24.3)	.125	(3.2)	.312	(7.9)	04
115	12	1	3.062	(77.8)	1.027	(26.1)	.957	(24.3)	.125	(3.2)	.312	(7.9)	04
116	14	1	2.062	(52.4)	1.027	(26.1)	1.145	(29.1)	.250	(6.4)	.437	(11.1)	06
117	14	1	3.062	(77.8)	1.027	(26.1)	1.145	(29.1)	.250	(6.4)	.437	(11.1)	06
118	16	1	2.062	(52.4)	1.027	(26.1)	1.332	(33.8)	.350	(8.9)	.625	(15.9)	10
119	16	1	3.062	(77.8)	1.027	(26.1)	1.332	(33.8)	.350	(8.9)	.625	(15.9)	10
120	18	1	2.062	(52.4)	1.027	(26.1)	.957	(24.3)	.125	(3.2)	.312	(7.9)	04
121	18	1	3.062	(77.8)	1.027	(26.1)	.957	(24.3)	.125	(3.2)	.312	(7.9)	04
122	18	1	2.062	(52.4)	1.027	(26.1)	1.145	(29.1)	.250	(6.4)	.437	(11.1)	06
123	18	1	3.062	(77.8)	1.027	(26.1)	1.145	(29.1)	.250	(6.4)	.437	(11.1)	06
124	20	1	3.062	(77.8)	1.027	(26.1)	1.145	(29.1)	.250	(6.4)	.437	(11.1)	06
125	20	1	4.062	(103.2)	1.027	(26.1)	1.145	(29.1)	.250	(6.4)	.437	(11.1)	06
126	22	1	3.062	(77.8)	1.027	(26.1)	.957	(24.3)	.125	(3.2)	.312	(7.9)	04
127	22	1	4.062	(103.2)	1.027	(26.1)	.957	(24.3)	.125	(3.2)	.312	(7.9)	04
128	22	1	3.062	(77.8)	1.027	(26.1)	1.145	(29.1)	.250	(6.4)	.437	(11.1)	0
129	22	1	4.062	(103.2)	1.027	(26.1)	1.145	(29.1)	.250	(6.4)	.437	(11.1)	06
130	24	1	3.062	(77.8)	1.027	(26.1)	1.332	(33.8)	.350	(8.9)	.625	(15.9)	10
131	24	1	4.062	(103.2)	1.027	(26.1)	1.332	(33.8)	.350	(8.9)	.625	(15.9)	10
132	36	1	4.062	(103.2)	1.059	(26.9)	1.551	(39.4)	.500	(12.7)	.750	(19.1)	12
133	36	1	5.062	(128.6)	1.059	(26.9)	1.551	(39.4)	.500	(12.7)	.750	(19.1)	12
134	40	1	4.062	(103.2)	1.059	(26.9)	1.551	(39.4)	.500	(12.7)	.750	(19.1)	12
135	40	1	5.062	(128.6)	1.059	(26.9)	1.551	(39.4)	.500	(12.7)	.750	(19.1)	12
136	10	1	2.062	(52.4)	1.027	(26.1)	1.145	(29.1)	.250	(6.4)	.375	(9.5)	06
137	10	1	3.062	(77.8)	1.027	(26.1)	1.145	(29.1)	.250	(6.4)	.375	(9.5)	06
138	12	1	2.062	(52.4)	1.027	(26.1)	1.332	(33.8)	.350	(8.9)	.500	(12.7)	10
139	12	1	3.062	(77.8)	1.027	(26.1)	1.332	(33.8)	.350	(8.9)	.500	(12.7)	10
140	20	1	3.062	(77.8)	1.156	(29.4)	1.770	(45.0)	.625	(15.9)	.904	(23.0)	16
141	20	1	4.062	(103.2)	1.156	(29.4)	1.770	(45.0)	.625	(15.9)	.904	(23.0)	16
142	22	1	3.062	(77.8)	1.375	(34.9)	2.113	(53.7)	.875	(22.2)	1.029	(26.1)	20
143	22	1	4.062	(103.2)	1.375	(34.9)	2.113	(53.7)	.875	(22.2)	1.029	(26.1)	20
144	24	1	3.062	(77.8)	1.375	(34.9)	2.113	(53.7)	.875	(22.2)	1.144	(29.1)	20
145	24	1	4.062	(103.2)	1.375	(34.9)	2.113	(53.7)	.875	(22.2)	1.144	(29.1)	20
146	36	1	4.062	(103.2)	1.830	(46.5)	3.020	(76.7)	1.437	(36.5)	1.840	(46.7)	32
147	36	1	5.062	(128.6)	1.830	(46.5)	3.020	(76.7)	1.437	(36.5)	1.840	(46.7)	32
148	36	1	4.062	(103.2)	1.156	(29.4)	1.770	(45.0)	.625	(15.9)	.937	(23.8)	16
149	36	1	5.062	(128.6)	1.156	(29.4)	1.770	(45.0)	.625	(15.9)	.937	(23.8)	16
150	14	1	2.062	(52.4)	1.027	(26.1)	.957	(24.3)	.125	(3.2)	.312	(7.9)	04
151	14	1	3.062	(77.8)	1.027	(26.1)	.957	(24.3)	.125	(3.2)	.312	(7.9)	04
152	16	1	2.062	(52.4)	1.027	(26.1)	.957	(24.3)	.125	(3.2)	.312	(7.9)	04
153	16	1	3.062	(77.8)	1.027	(26.1)	.957	(24.3)	.125	(3.2)	.312	(7.9)	04
154	44	1	4.062	(103.2)	1.156	(29.4)	1.770	(45.0)	.625	(15.9)	.937	(23.8)	16
155	44	1	5.062	(128.6)	1.156	(29.4)	1.770	(45.0)	.625	(15.9)	.937	(23.8)	16
156	40	1	4.062	(103.2)	1.156	(29.4)	1.770	(45.0)	.625	(15.9)	.937	(23.8)	16
157	40	1	5.062	(128.6)	1.156	(29.4)	1.770	(45.0)	.625	(15.9)	.937	(23.8)	16



AS85049/36
EMI/RFI Non-Environmental Backshell

Glenair Connector
Designator F

MIL-DTL-38999 Series I & II,
40M38277, PAN 6433-1, PATT
614, PATT 616,
NFC93422 Series HE308 &
HE309

M85049/36 10 N 03 A

Basic Part No. _____
Shell Size _____
Finish _____
Length Code (Omit for Standard) _____
Clamp Size _____
N = Electroless Nickel
W = 1,000 Hr. Cadmium Olive Drab
Over Electroless Nickel

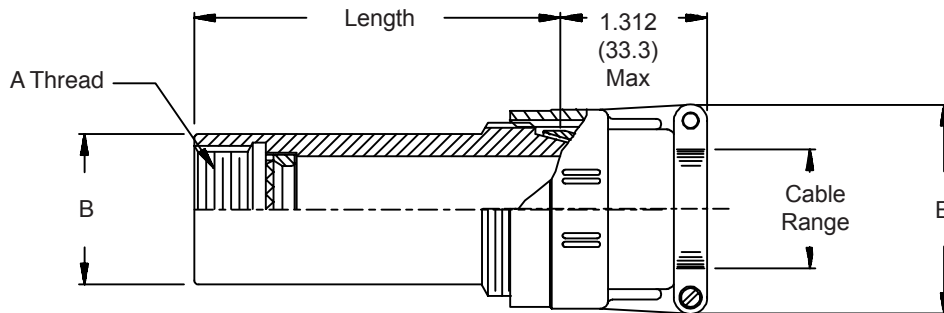

Shell Size	Series I Ref.	Clamp Size (Table IV)		A Thread Class 2B	B Dia Max
		Min	Max		
08	09	01	02	.438 - 28 UNEF	.65 (16.5)
10	11	01	03	.562 - 24 UNEF	.77 (19.6)
12	13	02	04	.688 - 24 UNEF	.89 (22.6)
14	15	02	05	.813 - 20 UNEF	1.02 (25.9)
16	17	02	06	.938 - 20 UNEF	1.15 (29.2)
18	19	03	07	1.063 - 18 UNEF	1.23 (31.2)
20	21	03	08	1.188 - 18 UNEF	1.36 (34.5)
22	23	03	09	1.313 - 18 UNEF	1.48 (37.6)
24	25	04	10	1.438 - 18 UNEF	1.73 (43.9)

Clamp Size	Cable Range		E Max
	Min	Max	
01	.062 (1.6)	.125 (3.2)	.781 (19.8)
02	.125 (3.2)	.250 (6.4)	.969 (24.6)
03	.250 (6.4)	.375 (9.5)	1.062 (27.0)
04	.312 (7.9)	.500 (12.7)	1.156 (29.4)
05	.437 (11.1)	.625 (15.9)	1.250 (31.8)
06	.562 (14.3)	.750 (19.1)	1.375 (34.9)
07	.687 (17.4)	.875 (22.2)	1.500 (38.1)
08	.812 (20.6)	1.000 (25.4)	1.625 (41.3)
09	.937 (23.8)	1.125 (28.6)	1.750 (44.5)
10	1.062 (27.0)	1.250 (31.8)	1.875 (47.6)

- For complete dimensions see applicable Military Specification.
- Metric dimensions (mm) are indicated in parentheses.
- Cable range is defined as the accommodation range for the wire bundle or cable. Dimensions shown are not intended for inspection criteria.

Length Code	Available Shell Sizes		Length
	Min	Max	
Std.	08 - 24		1.50 (38.1)
A	08 - 24		2.50 (63.5)
B	14 - 24		3.50 (88.9)
C	20 - 24		4.50 (114.3)

AS85049/37 EMI/RFI Non-Environmental Backshells



EMI/RFI
Non-Env.
Backshells

Glenair Connector
Designator F

MIL-DTL-38999 Series I & II,
40M38277, PAN 6433-1,
PATT 614, PATT 616,
NFC93422 Series HE308 &
HE309

M85049/37 10 W 03 L

Basic Part No. _____
Shell Size _____
Finish _____
D = 3 Drain Holes
L = Encapsulating Hole
Clamp Size _____
N = Electroless Nickel
W = 1,000 Hr. Cadmium Olive Drab
Over Electroless Nickel

TABLE I

Shell Size			
Shell Size	Series I Ref.	A Thread Class 2B	C Dia Max
8	09	.438 - 28 UNEF	.65 (16.5)
10	11	.562 - 24 UNEF	.77 (19.6)
12	13	.688 - 24 UNEF	.89 (22.6)
14	15	.813 - 20 UNEF	1.02 (25.9)
16	17	.938 - 20 UNEF	1.15 (29.2)
18	19	1.063 - 18 UNEF	1.23 (31.2)
20	21	1.188 - 18 UNEF	1.36 (34.5)
22	23	1.313 - 18 UNEF	1.48 (37.6)
24	25	1.438 - 18 UNEF	1.73 (43.9)

TABLE II

Shell Size						
Shell Size	Series I Ref.	E Max	F Max	Clamp Size		
8	09	.72 (18.3)	2.50 (63.5)	01	02	
10	11	.72 (18.3)	2.50 (63.5)	01	03	
12	13	.80 (20.3)	2.56 (65.0)	02	04	
14	15	.85 (21.6)	2.69 (68.3)	02	05	
16	17	.91 (23.1)	2.81 (71.4)	02	06	
18	19	1.00 (25.4)	3.03 (77.0)	03	06	
20	21	1.05 (26.7)	3.19 (81.0)	03	07	
22	23	1.10 (27.9)	3.31 (84.1)	03	08	
24	25	1.20 (30.5)	3.31 (84.1)	04	09	

TABLE III

Clamp Size	Cable Range		G Max
	Min	Max	
01	.062 (1.6)	.125 (3.2)	.781 (19.8)
02	.125 (3.2)	.250 (6.4)	.969 (24.6)
03	.250 (6.4)	.375 (9.5)	1.062 (27.0)
04	.312 (7.9)	.500 (12.7)	1.156 (29.4)
05	.437 (11.1)	.625 (15.9)	1.250 (31.8)
06	.562 (14.3)	.750 (19.1)	1.375 (34.9)
07	.687 (17.4)	.875 (22.2)	1.500 (38.1)
08	.812 (20.6)	1.000 (25.4)	1.625 (41.3)
09	.937 (23.8)	1.125 (28.6)	1.750 (44.5)
10	1.062 (27.0)	1.250 (31.8)	1.875 (47.6)

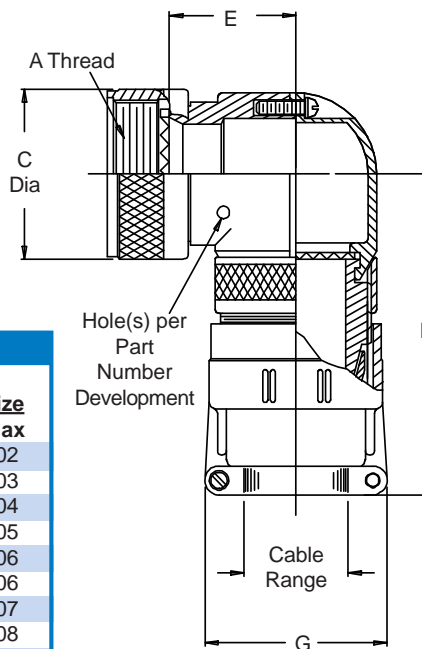

1. For complete dimensions see applicable Military Specification.
2. Metric dimensions (mm) are indicated in parentheses.
3. Cable range is defined as the accommodation range for the wire bundle or cable. Dimensions shown are not intended for inspection criteria.

Ten Reasons to Keep Glenair at the Top of Your List of Backshell Suppliers

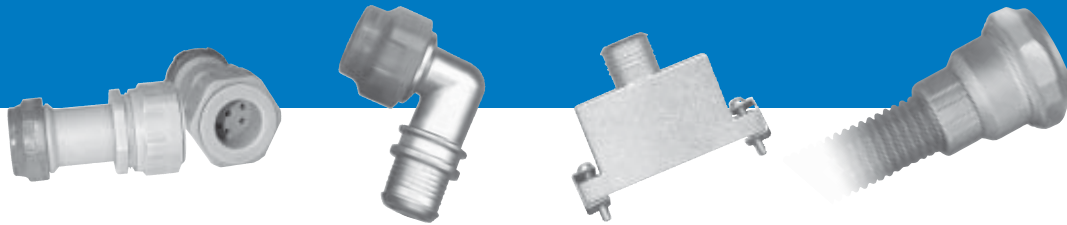

1. We offer the lowest total cost of ownership in the interconnect industry: From our cost-saving "no minimum order" policy to our free product samples and application engineering, Glenair provides the best value in connector accessories available today.

2. Our full spectrum product lines make for one-stop-shopping: We have the most complete selection of rectangular backshells and accessories in the world, including every Mil-Spec slash number and more composite designs than the rest of the industry combined.

3. We have the largest capacity, broadest capability factory in the business and the knowledge and expertise to handle any production requirement no matter how large or complex.

4. We've provided complete convenience in ordering since 1956 (that's *your* convenience not ours): choose factory direct, your local Glenair office or your favorite distributor.

5. We care as much about quality as you do: We're BSENISO9001 registered in Europe and MIL-I-45208A and Boeing AQS D1-9000 Certified in North America.

6. We have over 30,000 accessory part numbers ready for immediate shipment including every Mil-C-85049 accessory and thousands of Glenair's most popular rectangular and circular backshell part numbers.

7. Our turnaround on quotes and custom orders is the fastest in the industry: We offer 24 hour turnaround on RFQ's and just 2 to 3 weeks delivery on custom orders, including Micro-Ds and other rectangular interconnects.

8. We have the largest and most experienced support staff in the business, including sales and engineering in every major aerospace market, on-site application engineering and dedicated product managers for every interconnect discipline.

9. We understand interconnect systems from the ground up: We're the only connector, backshell and accessory supplier to operate a full service harness facility. We even make our own line of assembly tools.

10. We're committed: Backshells and connector accessories are our life. We've served this market since 1956 and we're committed to meeting the evolving needs of our customers.

Glenair: A World of Interconnect Solutions

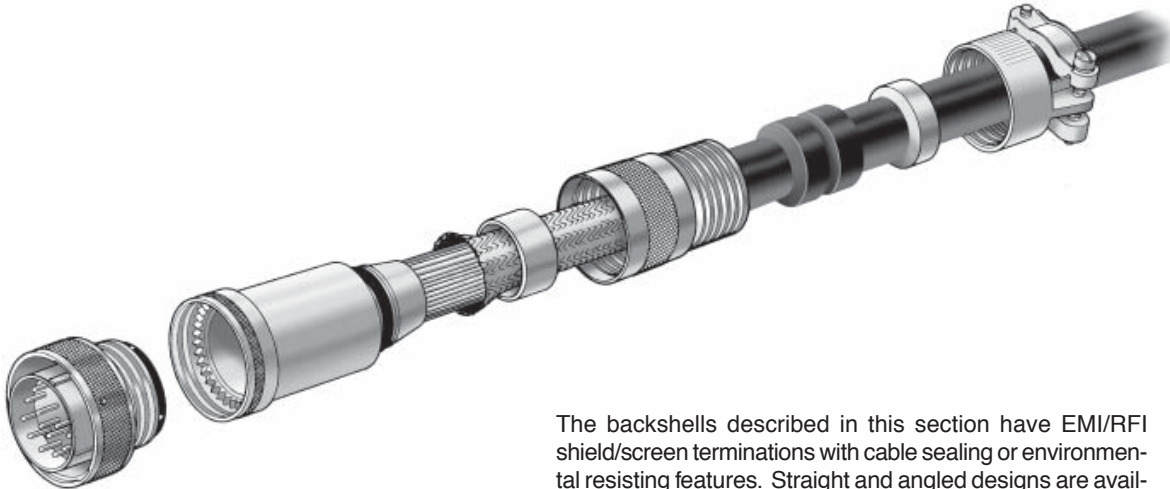

The backshells described in this section have EMI/RFI shield/screen terminations with cable sealing or environmental resisting features. Straight and angled designs are available.

Military Specification	Superceding Part Number	Glenair's Commercial Catalog P/N	Description	Glenair Connector Designator	Page Number
MS3188A	M85049/8	390AA001	90° Backshell	A	39-10
MS3189A	M85049/6	390AB001	45° Backshell	A	39-8
MS3437A	M85049/10	390AS001	Straight Backshell	A	39-12
M28840/6A		**	Straight Backshell	G	39-2
M28840/8A		**	90° Split Backshell	G	39-3
M28840/9A		**	45° Split Backshell	G	39-4
M38999/5	M85049/17	390FS012	Straight Backshell	F	39-16*
M81511/14 (A,B)		390JS012	Straight Backshell	J	39-6
AS85049/6		390AB001	45° Backshell	A	39-8
AS85049/8		390AA001	90° Backshell	A	39-10
AS85049/10		390AS001	Straight Backshell	A	39-12
AS85049/17		390FS012	Straight Backshell	F	39-16
AS85049/18		390HS011	Straight Backshell	H	39-17
AS85049/76		390FL011	90° Backshell	F	39-18
AS85049/77		390FK011	45° Backshell	F	39-19
AS85049/78		390HK011	45° Backshell	H	39-20
AS85049/79		390HL011	90° Backshell	H	39-21

* Page Number of Superceding Part Number
** Consult Factory



M28840/6 A EMI/RFI Environmental Backshell

Glenair Connector Designator G

MIL-C-28840

M28840/6 16 W A

Basic Part No.

Dash No. (Table II)

Style Designator - A = EMI/Environmental

Material and Finish Designator

D = Corrosion Resistant Steel,

Cadmium Plate, Black

W = Aluminum, Cadmium Olive

Drab over Electroless Nickel

TABLE I

Shell Size	A Thread Class 2B	C Dia Max
11	.750 - 20 UNEF	1.028 (26.1)
13	.875 - 20 UNEF	1.141 (29.0)
15	1.000 - 20 UNEF	1.263 (32.1)
17	1.125 - 18 UNEF	1.387 (35.2)
19	1.250 - 18 UNEF	1.513 (38.4)
23	1.438 - 18 UNEF	1.703 (43.3)
25	1.562 - 18 UNEF	1.825 (46.4)
29	1.875 - 16 UN	2.143 (54.4)
33	2.062 - 16 UNS	2.329 (59.2)

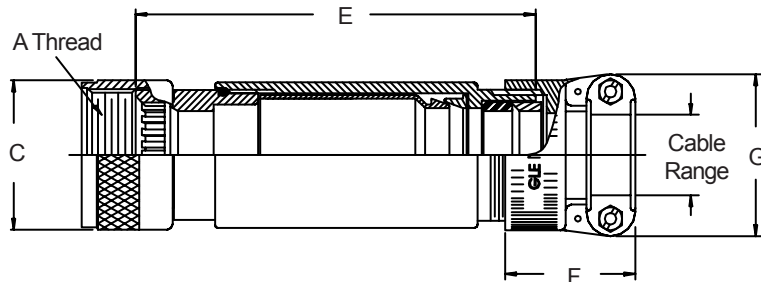

TABLE II

Dash No.	Shell Size	E Ref.	E ±.12 (3.0)	F Ref. Dim	G Ref. Dim	Cable Range	
						Min	Max
01	11	3.62	(91.9)	1.281 (32.5)	.938 (23.8)	.188 (4.8)	.312 (7.9)
02	13	3.62	(91.9)	1.281 (32.5)	.938 (23.8)	.188 (4.8)	.312 (7.9)
03	13	3.62	(91.9)	1.281 (32.5)	1.125 (28.6)	.281 (7.1)	.438 (11.1)
04	15	3.62	(91.9)	1.281 (32.5)	.938 (23.8)	.188 (4.8)	.312 (7.9)
05	15	3.62	(91.9)	1.281 (32.5)	1.125 (28.6)	.281 (7.1)	.438 (11.1)
06	15	3.62	(91.9)	1.281 (32.5)	1.312 (33.3)	.344 (8.7)	.562 (14.3)
07	15	4.12	(104.6)	1.312 (33.3)	1.593 (40.5)	.438 (11.1)	.750 (19.1)
08	17	4.12	(104.6)	1.281 (32.5)	1.312 (33.3)	.375 (9.5)	.625 (15.9)
09	17	4.12	(104.6)	1.312 (33.3)	1.593 (40.5)	.438 (11.1)	.750 (19.1)
10	17	4.12	(104.6)	1.406 (35.7)	1.750 (44.5)	.625 (15.9)	.938 (23.8)
11	19	4.12	(104.6)	1.281 (32.5)	1.312 (33.3)	.375 (9.5)	.625 (15.9)
12	19	4.12	(104.6)	1.406 (35.7)	1.750 (44.5)	.625 (15.9)	.938 (23.8)
13	23	4.62	(117.3)	1.312 (33.3)	1.593 (40.5)	.438 (11.1)	.750 (19.1)
14	23	4.62	(117.3)	1.406 (35.7)	1.750 (44.5)	.625 (15.9)	.938 (23.8)
15	23	4.62	(117.3)	1.593 (40.5)	2.093 (53.2)	.812 (20.6)	1.188 (30.2)
16	25	4.62	(117.3)	1.406 (35.7)	1.750 (44.5)	.625 (15.9)	.938 (23.8)
17	25	5.12	(130.0)	1.593 (40.5)	2.093 (53.2)	.812 (20.6)	1.188 (30.2)
18	25	5.12	(130.0)	1.593 (40.5)	2.093 (53.2)	.875 (22.2)	1.250 (31.8)
19	25	5.12	(130.0)	1.625 (41.3)	2.343 (59.5)	1.000 (25.4)	1.380 (35.1)
20	29	5.12	(130.0)	1.593 (40.5)	2.093 (53.2)	.812 (20.6)	1.188 (30.2)
21	29	5.12	(130.0)	1.625 (41.3)	2.343 (59.5)	1.000 (25.4)	1.380 (35.1)
22	33	5.12	(130.0)	1.625 (41.3)	2.343 (59.5)	1.000 (25.4)	1.380 (35.1)
23	33	5.12	(130.0)	1.900 (48.3)	2.750 (69.9)	1.250 (31.8)	1.625 (41.3)
24	11	3.62	(91.9)	1.281 (32.5)	1.125 (28.6)	.281 (7.1)	.438 (11.1)
25	11	3.62	(91.9)	1.281 (32.5)	1.312 (33.3)	.344 (8.7)	.562 (14.3)
26	13	3.62	(91.9)	1.281 (32.5)	1.312 (33.3)	.344 (8.7)	.562 (14.3)
27	13	4.12	(104.6)	1.281 (32.5)	1.312 (33.3)	.375 (9.5)	.625 (15.9)
28	15	4.12	(104.6)	1.281 (32.5)	1.312 (33.3)	.375 (9.5)	.625 (15.9)

1. For complete dimensions see applicable Military Specification.
2. Metric dimensions (mm) are indicated in parentheses.
3. Cable range is defined as the accommodations range for the wire bundle or cable. Dimensions shown are not intended for inspection criteria.

M28840/8 A EMI/RFI Environmental Backshell



EMI/RFI
Environmental
Backshells

M28840/8 16 W A

Glenair Connector Designator G

MIL-C-28840

Basic Part No. ————

Dash No. (Table II) ————

Style Designator - A = EMI/Environmental

Material and Finish Designator
D = Corrosion Resistant Steel, Cadmium Plate, Black
W = Aluminum, Cadmium Olive
Drab over Electroless Nickel

TABLE I

Shell Size	A Thread Class2B	C Dia Max
11	.750 - 20 UNEF	1.028 (26.1)
13	.875 - 20 UNEF	1.141 (29.0)
15	1.000 - 20 UNEF	1.263 (32.1)
17	1.125 - 18 UNEF	1.387 (35.2)
19	1.250 - 18 UNEF	1.513 (38.4)
23	1.438 - 18 UNEF	1.703 (43.3)
25	1.562 - 18 UNEF	1.825 (46.4)
29	1.875 - 16 UN	2.143 (54.4)
33	2.062 - 16 UNS	2.329 (59.2)

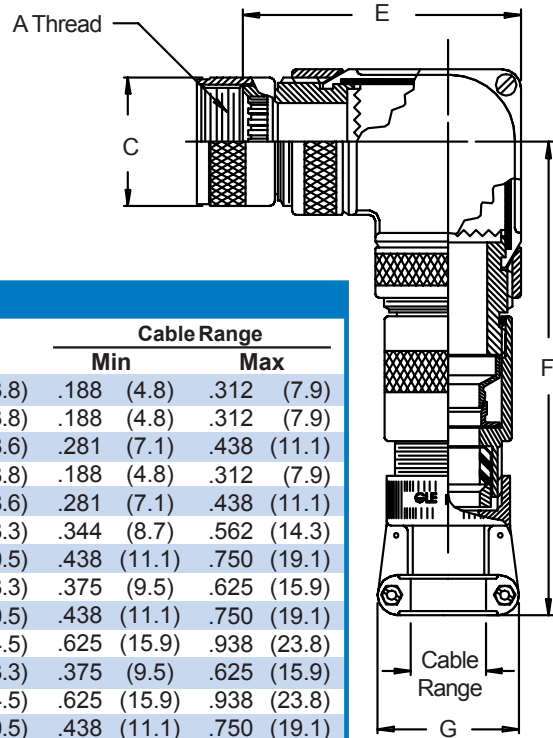

TABLE II

Dash No.	Shell Size Ref.	E Max Envelope		F Max	G Ref. Dim	Cable Range	
		Min	Max			Min	Max
01	11	2.614 (66.4)	5.332 (135.4)	.938 (23.8)	.188 (4.8)	.312 (7.9)	
02	13	2.614 (66.4)	5.332 (135.4)	.938 (23.8)	.188 (4.8)	.312 (7.9)	
03	13	2.614 (66.4)	5.332 (135.4)	1.125 (28.6)	.281 (7.1)	.438 (11.1)	
04	15	2.864 (72.7)	5.457 (138.6)	.938 (23.8)	.188 (4.8)	.312 (7.9)	
05	15	2.864 (72.7)	5.457 (138.6)	1.125 (28.6)	.281 (7.1)	.438 (11.1)	
06	15	2.864 (72.7)	5.457 (138.6)	1.312 (33.3)	.344 (8.7)	.562 (14.3)	
07	15	3.114 (79.1)	5.682 (144.3)	1.593 (40.5)	.438 (11.1)	.750 (19.1)	
08	17	3.114 (79.1)	5.682 (144.3)	1.312 (33.3)	.375 (9.5)	.625 (15.9)	
09	17	3.114 (79.1)	5.713 (145.1)	1.593 (40.5)	.438 (11.1)	.750 (19.1)	
10	17	3.114 (79.1)	5.807 (147.5)	1.750 (44.5)	.625 (15.9)	.938 (23.8)	
11	19	3.114 (79.1)	5.682 (144.3)	1.312 (33.3)	.375 (9.5)	.625 (15.9)	
12	19	3.364 (85.4)	5.832 (148.1)	1.750 (44.5)	.625 (15.9)	.938 (23.8)	
13	23	3.364 (85.4)	5.738 (145.7)	1.593 (40.5)	.438 (11.1)	.750 (19.1)	
14	23	3.364 (85.4)	5.832 (148.1)	1.750 (44.5)	.625 (15.9)	.938 (23.8)	
15	23	3.364 (85.4)	6.019 (152.9)	2.093 (53.2)	.812 (20.6)	1.188 (30.2)	
16	25	3.364 (85.4)	5.832 (148.1)	1.750 (44.5)	.625 (15.9)	.938 (23.8)	
17	25	3.364 (85.4)	6.019 (152.9)	2.093 (53.2)	.812 (20.6)	1.188 (30.2)	
18	25	3.614 (91.8)	6.144 (156.1)	2.093 (53.2)	.875 (22.2)	1.250 (31.8)	
19	25	3.614 (91.8)	6.176 (156.9)	2.343 (59.5)	1.000 (25.4)	1.380 (35.1)	
20	29	3.614 (91.8)	6.144 (156.1)	2.093 (53.2)	.812 (20.6)	1.188 (30.2)	
21	29	3.614 (91.8)	6.176 (156.9)	2.343 (59.5)	1.000 (25.4)	1.380 (35.1)	
22	33	4.114 (104.5)	6.426 (163.2)	2.343 (59.5)	1.000 (25.4)	1.380 (35.1)	
23	33	4.114 (104.5)	6.701 (170.2)	2.750 (69.9)	1.250 (31.8)	1.625 (41.3)	
24	11	2.614 (66.4)	5.332 (135.4)	1.125 (28.6)	.281 (7.1)	.438 (11.1)	
25	11	2.864 (72.7)	5.457 (138.6)	1.312 (33.3)	.344 (8.7)	.562 (14.3)	
26	13	2.864 (72.7)	5.457 (138.6)	1.312 (33.3)	.344 (8.7)	.562 (14.3)	
27	13	3.114 (79.1)	5.682 (144.3)	1.312 (33.3)	.375 (9.5)	.625 (15.9)	
28	15	3.114 (79.1)	5.682 (144.3)	1.312 (33.3)	.375 (9.5)	.625 (15.9)	

- For complete dimensions see applicable Military Specification.
- Cable range is defined as the accommodations range for the wire bundle or cable. Dimensions shown are not intended for inspection criteria.

**Glenair Connector
Designator G**

MIL-C-28840

M28840/9 16 W A

Basic Part No.

Dash No. (Table II)

Style Designator - A = EMI/Environmental

Material and Finish Designator
D = Corrosion Resistant Steel,
Cadmium Plate, Black
W = Aluminum, Cadmium Olive
Drab over Electroless Nickel

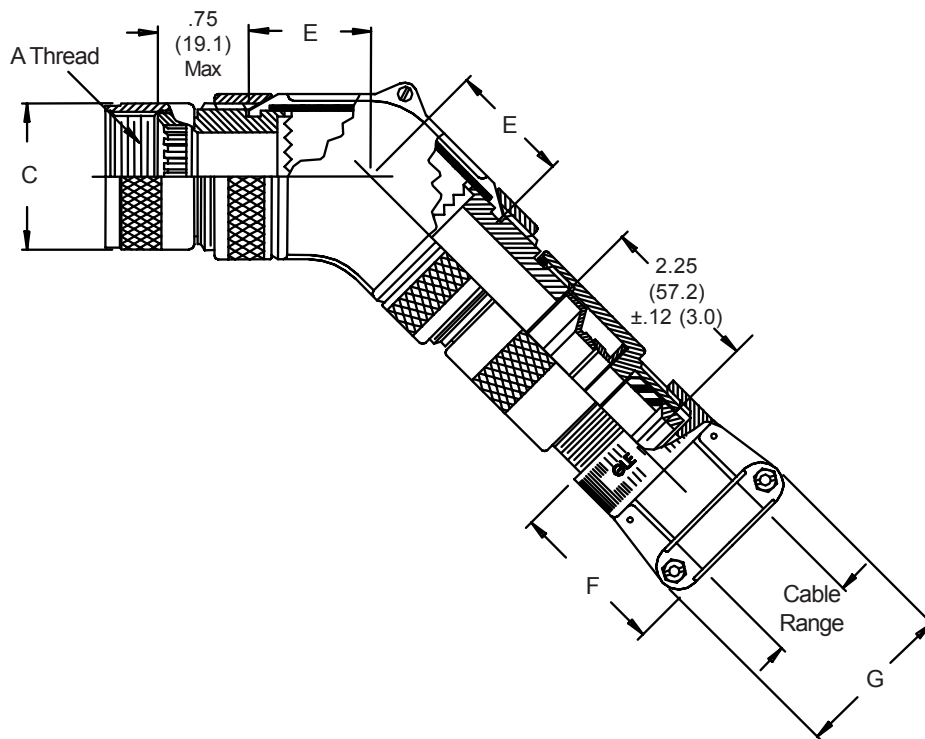

1. For complete dimensions see applicable Military Specification.
2. Metric dimensions (mm) are indicated in parentheses.
3. Cable range is defined as the accommodations range for the wire bundle or cable. Dimensions shown are not intended for inspection criteria.

M28840/9 A
EMI/RFI Environmental Backshell



EMI/RFI
Environmental
Backshells

TABLE I

Shell Size	A Thread Class 2B	C Dia Max
11	.750 - 20 UNEF	1.028 (26.1)
13	.875 - 20 UNEF	1.141 (29.0)
15	1.000 - 20 UNEF	1.263 (32.1)
17	1.125 - 18 UNEF	1.387 (35.2)
19	1.250 - 18 UNEF	1.513 (38.4)
23	1.438 - 18 UNEF	1.703 (43.3)
25	1.562 - 18 UNEF	1.825 (46.4)
29	1.875 - 16 UN	2.143 (54.4)
33	2.062 - 16 UNS	2.329 (59.2)

TABLE II

Dash No.	Shell Size Ref.	E Max	F Ref. Dim	G Ref. Dim	Cable Range		
					Min	Max	
01	11	1.031 (26.2)	1.281 (32.5)	.938 (23.8)	.188 (4.8)	.312 (7.9)	
02	13	1.031 (26.2)	1.281 (32.5)	.938 (23.8)	.188 (4.8)	.312 (7.9)	
03	13	1.031 (26.2)	1.281 (32.5)	1.125 (28.6)	.281 (7.1)	.438 (11.1)	
04	15	1.156 (29.4)	1.281 (32.5)	.938 (23.8)	.188 (4.8)	.312 (7.9)	
05	15	1.156 (29.4)	1.281 (32.5)	1.125 (28.6)	.281 (7.1)	.438 (11.1)	
06	15	1.156 (29.4)	1.281 (32.5)	1.312 (33.3)	.344 (8.7)	.562 (14.3)	
07	15	1.281 (32.5)	1.312 (33.3)	1.593 (40.5)	.438 (11.1)	.750 (19.1)	
08	17	1.281 (32.5)	1.281 (32.5)	1.312 (33.3)	.375 (9.5)	.625 (15.9)	
09	17	1.281 (32.5)	1.312 (33.3)	1.593 (40.5)	.438 (11.1)	.750 (19.1)	
10	17	1.281 (32.5)	1.406 (35.7)	1.750 (44.5)	.625 (15.9)	.938 (23.8)	
11	19	1.281 (32.5)	1.281 (32.5)	1.312 (33.3)	.375 (9.5)	.625 (15.9)	
12	19	1.406 (35.7)	1.406 (35.7)	1.750 (44.5)	.625 (15.9)	.938 (23.8)	
13	23	1.406 (35.7)	1.312 (33.3)	1.593 (40.5)	.438 (11.1)	.750 (19.1)	
14	23	1.406 (35.7)	1.406 (35.7)	1.750 (44.5)	.625 (15.9)	.938 (23.8)	
15	23	1.406 (35.7)	1.593 (40.5)	2.093 (53.2)	.812 (20.6)	1.188 (30.2)	
16	25	1.406 (35.7)	1.406 (35.7)	1.750 (44.5)	.625 (15.9)	.938 (23.8)	
17	25	1.406 (35.7)	1.593 (40.5)	2.093 (53.2)	.812 (20.6)	1.188 (30.2)	
18	25	1.531 (38.9)	1.593 (40.5)	2.093 (53.2)	.875 (22.2)	1.250 (31.8)	
19	25	1.531 (38.9)	1.625 (41.3)	2.343 (59.5)	1.000 (25.4)	1.380 (35.1)	
20	29	1.531 (38.9)	1.593 (40.5)	2.093 (53.2)	.812 (20.6)	1.188 (30.2)	
21	29	1.531 (38.9)	1.625 (41.3)	2.343 (59.5)	1.000 (25.4)	1.380 (35.1)	
22	33	1.781 (45.2)	1.625 (41.3)	2.343 (59.5)	1.000 (25.4)	1.380 (35.1)	
23	33	1.781 (45.2)	1.900 (48.3)	2.750 (69.9)	1.250 (31.8)	1.625 (41.3)	
24	11	1.031 (26.2)	1.281 (32.5)	1.125 (28.6)	.281 (7.1)	.438 (11.1)	
25	11	1.156 (29.4)	1.281 (32.5)	1.312 (33.3)	.344 (8.7)	.562 (14.3)	
26	13	1.156 (29.4)	1.281 (32.5)	1.312 (33.3)	.344 (8.7)	.562 (14.3)	
27	13	1.281 (32.5)	1.281 (32.5)	1.312 (33.3)	.375 (9.5)	.625 (15.9)	
28	15	1.281 (32.5)	1.281 (32.5)	1.312 (33.3)	.375 (9.5)	.625 (15.9)	



M81511/14 Functions A and B RFI Environmental Backshells

**Glenair Connector
Designator J**

M81511/14-050

Basic Part No. _____ Dash No. _____

1. For complete dimensions see applicable Military Specification.
2. Metric dimensions (mm) are indicated in parentheses.
3. For Functions C and D see page 38-2.

MIL-C-81511

Inactive for New Design

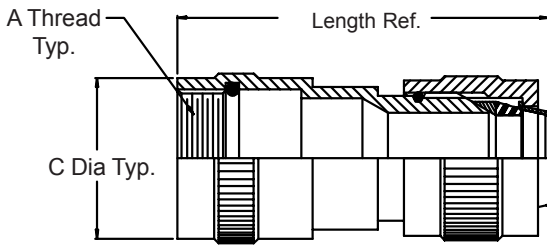

Function "A" Adapter Assembly

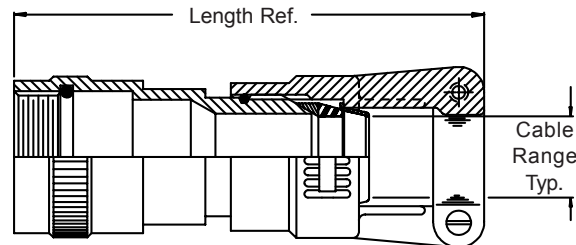

Function "B" Adapter Assembly

TABLE I

Dash No.	Shell Size	Function	A Thread Class 2B	C Dia. Max	Length Ref.	Cable Range	
						Min	Max
001	08	A	.500 - 28 UNEF			.062 (1.6)	.125 (3.2)
002	08	A	.500 - 28 UNEF	.555 (14.1)	2.22 (56.4)	.125 (3.2)	.250 (6.4)
003	08	B	.500 - 28 UNEF			.062 (1.6)	.125 (3.2)
004	08	B	.500 - 28 UNEF	.555 (14.1)	2.72 (69.1)	.125 (3.2)	.250 (6.4)
005	08	A	.500 - 28 UNEF			.062 (1.6)	.125 (3.2)
006	08	A	.500 - 28 UNEF	.555 (14.1)	2.72 (69.1)	.125 (3.2)	.250 (6.4)
007	08	B	.500 - 28 UNEF			.062 (1.6)	.125 (3.2)
008	08	B	.500 - 28 UNEF	.555 (14.1)	3.22 (81.8)	.125 (3.2)	.250 (6.4)
009	10	A	.625 - 28 UN			.125 (3.2)	.250 (6.4)
010	10	A	.625 - 28 UN	.680 (17.3)	2.22 (56.4)	.250 (6.4)	.375 (9.5)
011	10	A	.625 - 28 UN			.375 (9.5)	.500 (12.7)
012	10	B	.625 - 28 UN	.680 (17.3)	2.72 (69.1)	.125 (3.2)	.250 (6.4)
013	10	B	.625 - 28 UN			.250 (6.4)	.375 (9.5)
014	10	B	.625 - 28 UN	.680 (17.3)	2.72 (69.1)	.375 (9.5)	.500 (12.7)
015	10	A	.625 - 28 UN			.125 (3.2)	.250 (6.4)
016	10	A	.625 - 28 UN	.680 (17.3)	2.72 (69.1)	.250 (6.4)	.375 (9.5)
017	10	A	.625 - 28 UN			.375 (9.5)	.500 (12.7)
018	10	B	.625 - 28 UN	.680 (17.3)	3.22 (81.8)	.125 (3.2)	.250 (6.4)
019	10	B	.625 - 28 UN			.250 (6.4)	.375 (9.5)
020	10	B	.625 - 28 UN	.680 (17.3)	3.22 (81.8)	.375 (9.5)	.500 (12.7)
021	14	A	.875 - 28 UN			.250 (6.4)	.375 (9.5)
022	14	A	.875 - 28 UN	.930 (23.6)	2.22 (56.4)	.375 (9.5)	.500 (12.7)
023	14	A	.875 - 28 UN			.500 (12.7)	.625 (15.9)
024	14	B	.875 - 28 UN	.930 (23.6)	2.72 (69.1)	.250 (6.4)	.375 (9.5)
025	14	B	.875 - 28 UN			.375 (9.5)	.500 (12.7)
026	14	B	.875 - 28 UN	.930 (23.6)	2.72 (69.1)	.500 (12.7)	.625 (15.9)
027	14	A	.875 - 28 UN			.250 (6.4)	.375 (9.5)
028	14	A	.875 - 28 UN	.930 (23.6)	2.72 (69.1)	.375 (9.5)	.500 (12.7)
029	14	A	.875 - 28 UN			.500 (12.7)	.625 (15.9)
030	14	B	.875 - 28 UN	.930 (23.6)	3.22 (81.8)	.250 (6.4)	.375 (9.5)
031	14	B	.875 - 28 UN			.375 (9.5)	.500 (12.7)
032	14	B	.875 - 28 UN	.930 (23.6)	3.22 (81.8)	.500 (12.7)	.625 (15.9)
033	16	A	1.000 - 28 UN			.250 (6.4)	.375 (9.5)
034	16	A	1.000 - 28 UN	1.056 (26.8)	2.22 (56.4)	.375 (9.5)	.500 (12.7)
035	16	A	1.000 - 28 UN			.500 (12.7)	.625 (15.9)
036	16	B	1.000 - 28 UN	1.056 (26.8)	2.72 (69.1)	.250 (6.4)	.375 (9.5)
037	16	B	1.000 - 28 UN			.375 (9.5)	.500 (12.7)

Table I Continued on Page 39-7

M81511/14 Functions A and B RFI Environmental Backshells



EM/RFI
Environmental
Backshells

TABLE I (Continued From Page 39-6)

Dash No.	Shell Size	Function	A Thread Class 2B	C Dia. Max	Length Ref.	Cable Range		
						Min	Max	Max
038	16	B	1.000 - 28 UN	1.056 (26.8)	2.72 (69.1)	.500 (12.7)	.625 (15.9)	.625 (15.9)
039	16	A	1.000 - 28 UN	1.056 (26.8)	2.72 (69.1)	.250 (6.4)	.375 (9.5)	.375 (9.5)
040	16	A	1.000 - 28 UN	1.056 (26.8)	2.72 (69.1)	.375 (9.5)	.500 (12.7)	.500 (12.7)
041	16	A	1.000 - 28 UN	1.056 (26.8)	2.72 (69.1)	.500 (12.7)	.625 (15.9)	.625 (15.9)
042	16	B	1.000 - 28 UN	1.056 (26.8)	3.22 (81.8)	.250 (6.4)	.375 (9.5)	.375 (9.5)
043	16	B	1.000 - 28 UN	1.056 (26.8)	3.22 (81.8)	.375 (9.5)	.500 (12.7)	.500 (12.7)
044	16	B	1.000 - 28 UN	1.056 (26.8)	3.22 (81.8)	.500 (12.7)	.625 (15.9)	.625 (15.9)
045	18	A	1.125 - 28 UN	1.180 (30.0)	2.22 (56.4)	.375 (9.5)	.500 (12.7)	.500 (12.7)
046	18	A	1.125 - 28 UN	1.180 (30.0)	2.22 (56.4)	.500 (12.7)	.625 (15.9)	.625 (15.9)
047	18	A	1.125 - 28 UN	1.180 (30.0)	2.22 (56.4)	.625 (15.9)	.750 (19.1)	.750 (19.1)
048	18	B	1.125 - 28 UN	1.180 (30.0)	2.72 (69.1)	.375 (9.5)	.500 (12.7)	.500 (12.7)
049	18	B	1.125 - 28 UN	1.180 (30.0)	2.72 (69.1)	.500 (12.7)	.625 (15.9)	.625 (15.9)
050	18	B	1.125 - 28 UN	1.180 (30.0)	2.72 (69.1)	.625 (15.9)	.750 (19.1)	.750 (19.1)
051	18	A	1.125 - 28 UN	1.180 (30.0)	2.72 (69.1)	.375 (9.5)	.500 (12.7)	.500 (12.7)
052	18	A	1.125 - 28 UN	1.180 (30.0)	2.72 (69.1)	.500 (12.7)	.625 (15.9)	.625 (15.9)
053	18	A	1.125 - 28 UN	1.180 (30.0)	2.72 (69.1)	.625 (15.9)	.750 (19.1)	.750 (19.1)
054	18	B	1.125 - 28 UN	1.180 (30.0)	3.22 (81.8)	.375 (9.5)	.500 (12.7)	.500 (12.7)
055	18	B	1.125 - 28 UN	1.180 (30.0)	3.22 (81.8)	.500 (12.7)	.625 (15.9)	.625 (15.9)
056	18	B	1.125 - 28 UN	1.180 (30.0)	3.22 (81.8)	.625 (15.9)	.750 (19.1)	.750 (19.1)
113	20	A	1.250 - 28 UN	1.305 (33.1)	2.30 (58.4)	.500 (12.7)	.625 (15.9)	.625 (15.9)
114	20	A	1.250 - 28 UN	1.305 (33.1)	2.30 (58.4)	.625 (15.9)	.750 (19.1)	.750 (19.1)
115	20	A	1.250 - 28 UN	1.305 (33.1)	2.30 (58.4)	.750 (19.1)	.875 (22.2)	.875 (22.2)
116	20	B	1.250 - 28 UN	1.305 (33.1)	2.80 (71.1)	.500 (12.7)	.625 (15.9)	.625 (15.9)
117	20	B	1.250 - 28 UN	1.305 (33.1)	2.80 (71.1)	.625 (15.9)	.750 (19.1)	.750 (19.1)
118	20	B	1.250 - 28 UN	1.305 (33.1)	2.80 (71.1)	.750 (19.1)	.875 (22.2)	.875 (22.2)
119	20	A	1.250 - 28 UN	1.305 (33.1)	2.80 (71.1)	.500 (12.7)	.625 (15.9)	.625 (15.9)
120	20	A	1.250 - 28 UN	1.305 (33.1)	2.80 (71.1)	.625 (15.9)	.750 (19.1)	.750 (19.1)
121	20	A	1.250 - 28 UN	1.305 (33.1)	2.80 (71.1)	.750 (19.1)	.875 (22.2)	.875 (22.2)
122	20	B	1.250 - 28 UN	1.305 (33.1)	3.30 (83.8)	.500 (12.7)	.625 (15.9)	.625 (15.9)
123	20	B	1.250 - 28 UN	1.305 (33.1)	3.30 (83.8)	.625 (15.9)	.750 (19.1)	.750 (19.1)
124	20	B	1.250 - 28 UN	1.305 (33.1)	3.30 (83.8)	.750 (19.1)	.875 (22.2)	.875 (22.2)
125	22	A	1.375 - 28 UN	1.430 (36.3)	2.30 (58.4)	.625 (15.9)	.750 (19.1)	.750 (19.1)
126	22	A	1.375 - 28 UN	1.430 (36.3)	2.30 (58.4)	.750 (19.1)	.875 (22.2)	.875 (22.2)
127	22	A	1.375 - 28 UN	1.430 (36.3)	2.30 (58.4)	.875 (22.2)	1.000 (25.4)	1.000 (25.4)
128	22	B	1.375 - 28 UN	1.430 (36.3)	2.80 (71.1)	.625 (15.9)	.750 (19.1)	.750 (19.1)
129	22	B	1.375 - 28 UN	1.430 (36.3)	2.80 (71.1)	.750 (19.1)	.875 (22.2)	.875 (22.2)
130	22	B	1.375 - 28 UN	1.430 (36.3)	2.80 (71.1)	.875 (22.2)	1.000 (25.4)	1.000 (25.4)
131	22	A	1.375 - 28 UN	1.430 (36.3)	2.80 (71.1)	.625 (15.9)	.750 (19.1)	.750 (19.1)
132	22	A	1.375 - 28 UN	1.430 (36.3)	2.80 (71.1)	.750 (19.1)	.875 (22.2)	.875 (22.2)
133	22	A	1.375 - 28 UN	1.430 (36.3)	2.80 (71.1)	.875 (22.2)	1.000 (25.4)	1.000 (25.4)
134	22	B	1.375 - 28 UN	1.430 (36.3)	3.30 (83.8)	.625 (15.9)	.750 (19.1)	.750 (19.1)
135	22	B	1.375 - 28 UN	1.430 (36.3)	3.30 (83.8)	.750 (19.1)	.875 (22.2)	.875 (22.2)
136	22	B	1.375 - 28 UN	1.430 (36.3)	3.30 (83.8)	.875 (22.2)	1.000 (25.4)	1.000 (25.4)
137	24	A	1.500 - 28 UN	1.555 (39.5)	2.30 (58.4)	.750 (19.1)	.875 (22.2)	.875 (22.2)
138	24	A	1.500 - 28 UN	1.555 (39.5)	2.30 (58.4)	.875 (22.2)	1.000 (25.4)	1.000 (25.4)
139	24	A	1.500 - 28 UN	1.555 (39.5)	2.30 (58.4)	1.000 (25.4)	1.125 (28.6)	1.125 (28.6)
140	24	B	1.500 - 28 UN	1.555 (39.5)	2.80 (71.1)	.750 (19.1)	.875 (22.2)	.875 (22.2)
141	24	B	1.500 - 28 UN	1.555 (39.5)	2.80 (71.1)	.875 (22.2)	1.000 (25.4)	1.000 (25.4)
142	24	B	1.500 - 28 UN	1.555 (39.5)	2.80 (71.1)	1.000 (25.4)	1.125 (28.6)	1.125 (28.6)
143	24	A	1.500 - 28 UN	1.555 (39.5)	2.80 (71.1)	.750 (19.1)	.875 (22.2)	.875 (22.2)
144	24	A	1.500 - 28 UN	1.555 (39.5)	2.80 (71.1)	.875 (22.2)	1.000 (25.4)	1.000 (25.4)
145	24	A	1.500 - 28 UN	1.555 (39.5)	2.80 (71.1)	1.000 (25.4)	1.125 (28.6)	1.125 (28.6)
146	24	B	1.500 - 28 UN	1.555 (39.5)	3.30 (83.8)	.750 (19.1)	.875 (22.2)	.875 (22.2)
147	24	B	1.500 - 28 UN	1.555 (39.5)	3.30 (83.8)	.875 (22.2)	1.000 (25.4)	1.000 (25.4)
148	24	B	1.500 - 28 UN	1.555 (39.5)	3.30 (83.8)	1.000 (25.4)	1.125 (28.6)	1.125 (28.6)

1. For complete dimensions see applicable Military Specification.
2. Metric dimensions (mm) are indicated in parentheses.
3. For Functions C and D see page 38-2.



AS85049/6 and MS3189A EMI/RFI Environmental Backshells

**Glenair Connector
Designator A**

MIL-DTL-5015 Series 3400,
MIL-DTL-26482 Series 2,
AS81703 Series 3,
MIL-DTL-83723 Series I &
III, 40M39569, DEF 5326-3,
EN 2997, EN 3646,
ESC 10, ESC 11, LN 29504,
NFC93422 Series HE302,
PAN 6432-1, PAN 6432-2,
PATT 602

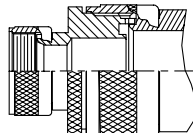

STYLE 2

1. For complete dimensions see applicable Military Specification.
2. Metric dimensions (mm) are indicated in parentheses.
3. When maximum cable entry is exceeded, Style 2 will be supplied.
4. Cable range is defined as the accommodations range for the wire bundle or cable. Dimensions shown are not intended for inspection criteria.

M85049/6-21 W

Basic Part No. _____ Finish
Dash No. _____

B = Black Cadmium, Stainless Steel
N = Electroless Nickel, Aluminum
S = Passivated Stainless Steel
W = 1,000 Hour Cad. Olive Drab Over Electroless Nickel, Aluminum

MS3189A 21 C

Basic Part No. _____ Finish (Material is Aluminum Only)
Dash No. _____

A = Cadmium Olive Drab over Nickel
C = Cadmium Olive Drab
N = Electroless Nickel

Superseded Part Number

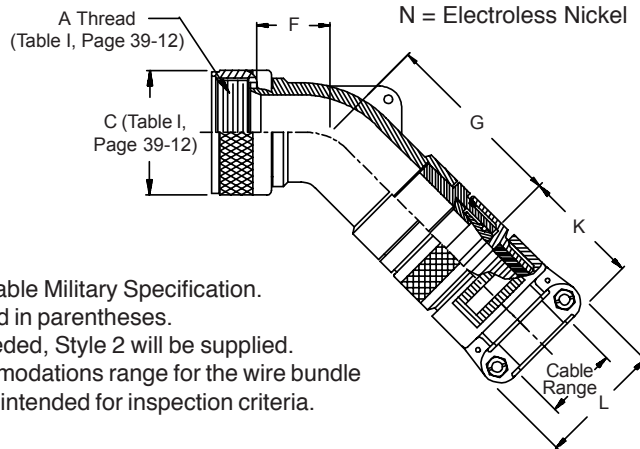

TABLE II

Dash No.	Shell Size	F Max	G Max	K Ref.	L Max	Cable Range		M85049/42 Ref
						Min	Max	
1	3	.686 (17.4)	1.852 (47.0)	1.544 (39.2)	.957 (24.3)	.125 (3.2)	.250 (6.4)	4
2*	3	1.500 (38.1)	1.972 (50.1)	1.544 (39.2)	1.145 (29.1)	.250 (6.4)	.437 (11.1)	6
3	8	.625 (15.9)	1.244 (31.6)	1.544 (39.2)	.957 (24.3)	.125 (3.2)	.250 (6.4)	4
4	10	.686 (17.4)	1.912 (48.6)	1.544 (39.2)	.957 (24.3)	.125 (3.2)	.312 (7.9)	4
5	10	.686 (17.4)	1.307 (33.2)	1.544 (39.2)	1.145 (29.1)	.250 (6.4)	.375 (9.5)	6
6	12	.750 (19.1)	1.972 (50.1)	1.544 (39.2)	.957 (24.3)	.125 (3.2)	.312 (7.9)	4
7	12	.750 (19.1)	1.972 (50.1)	1.544 (39.2)	1.145 (29.1)	.250 (6.4)	.437 (11.1)	6
8	12	.750 (19.1)	1.972 (50.1)	1.844 (46.8)	1.332 (33.8)	.350 (8.9)	.500 (12.7)	10
9	14	.813 (20.7)	2.062 (52.4)	1.544 (39.2)	1.145 (29.1)	.250 (6.4)	.437 (11.1)	6
10	14	.813 (20.7)	1.717 (43.6)	1.844 (46.8)	1.332 (33.8)	.350 (8.9)	.575 (14.6)	10
11	16	.906 (23.0)	2.172 (55.2)	1.544 (39.2)	1.145 (29.1)	.250 (6.4)	.437 (11.1)	6
12	16	.906 (23.0)	1.812 (46.0)	1.916 (48.7)	1.551 (39.4)	.500 (12.7)	.700 (17.8)	12
13	18	1.093 (27.8)	2.362 (60.0)	1.844 (46.8)	1.332 (33.8)	.350 (8.9)	.625 (15.9)	10
14	18	1.093 (27.8)	2.000 (50.8)	2.000 (50.8)	1.770 (45.0)	.625 (15.9)	.779 (19.8)	16
15	20	1.093 (27.8)	2.362 (60.0)	1.844 (46.8)	1.332 (33.8)	.350 (8.9)	.625 (15.9)	10
16	20	1.093 (27.8)	2.000 (50.8)	2.000 (50.8)	1.770 (45.0)	.625 (15.9)	.904 (23.0)	16
17	22	1.188 (30.2)	2.512 (63.8)	1.916 (48.7)	1.551 (39.4)	.500 (12.7)	.750 (19.1)	12
18	22	1.188 (30.2)	2.155 (54.7)	2.230 (56.6)	2.113 (53.7)	.875 (22.2)	1.029 (26.1)	20
19	24	1.188 (30.2)	2.512 (63.8)	1.916 (48.7)	1.551 (39.4)	.500 (12.7)	.750 (19.1)	12
20	24	1.188 (30.2)	2.155 (54.7)	2.230 (56.6)	2.113 (53.7)	.875 (22.2)	1.144 (29.1)	20
21	28	1.313 (33.4)	2.562 (65.1)	2.000 (50.8)	1.770 (45.0)	.625 (15.9)	.937 (23.8)	16

Table II Continued on Page 39-9

AS85049/6 and MS3189A EMI/RFI Environmental Backshells



EMI/RFI
Environmental
Backshells

TABLE II (Continued From Page 39-8)

Dash No.	Shell Size	F		G		K		L		Cable Range			M85049/42 Ref	
		Max	()	Max	()	Ref.	()	Max	()	Min	()	Max		()
22	28	1.312	(33.3)	2.218	(56.3)	2.024	(51.4)	2.363	(60.0)	1.000	(25.4)	1.375	(34.9)	24
23	32	1.375	(34.9)	2.662	(67.6)	2.000	(50.8)	1.770	(45.0)	.625	(15.9)	.937	(23.8)	16
24	32	1.375	(34.9)	2.662	(67.6)	2.230	(56.6)	2.113	(53.7)	.875	(22.2)	1.250	(31.8)	20
25	32	1.375	(34.9)	2.312	(58.7)	2.550	(64.8)	2.770	(70.4)	1.250	(31.8)	1.625	(41.3)	28
26	36	1.406	(35.7)	2.752	(69.9)	2.000	(50.8)	1.770	(45.0)	.625	(15.9)	.937	(23.8)	16
27	36	1.406	(35.7)	2.752	(69.9)	2.024	(51.4)	2.363	(60.0)	1.000	(25.4)	1.375	(34.9)	24
28	36	1.406	(35.7)	2.406	(61.1)	2.600	(66.0)	3.020	(76.7)	1.437	(36.5)	1.840	(46.7)	32
29	40	2.156	(54.8)	2.752	(69.9)	2.000	(50.8)	1.770	(45.0)	.625	(15.9)	.937	(23.8)	16
30	40	2.156	(54.8)	2.752	(69.9)	2.024	(51.4)	2.363	(60.0)	1.000	(25.4)	1.375	(34.9)	24
31	40	2.156	(54.8)	2.406	(61.1)	2.600	(66.0)	3.020	(76.7)	1.437	(36.5)	1.875	(47.6)	32
32	44	2.156	(54.8)	2.752	(69.9)	2.000	(50.8)	1.770	(45.0)	.625	(15.9)	.937	(23.8)	16
33	44	2.156	(54.8)	2.752	(69.9)	2.024	(51.4)	2.363	(60.0)	1.000	(25.4)	1.375	(34.9)	24
34	44	2.156	(54.8)	2.406	(61.1)	2.600	(66.0)	3.020	(76.7)	1.437	(36.5)	1.875	(47.6)	32
35	48	2.156	(54.8)	2.752	(69.9)	2.000	(50.8)	1.770	(45.0)	.625	(15.9)	.937	(23.8)	16
36	48	2.156	(54.8)	2.752	(69.9)	2.024	(51.4)	2.363	(60.0)	1.000	(25.4)	1.375	(34.9)	24
37	48	2.156	(54.8)	2.406	(61.1)	2.600	(66.0)	3.020	(76.7)	1.437	(36.5)	1.875	(47.6)	32
38	61	1.188	(30.2)	2.512	(63.8)	1.916	(48.7)	1.551	(39.4)	.500	(12.7)	.750	(19.1)	12
39	61	1.188	(30.2)	2.155	(54.7)	2.230	(56.6)	2.113	(53.7)	.875	(22.2)	1.184	(30.1)	20
40	16	.906	(23.0)	2.172	(55.2)	1.844	(46.8)	1.332	(33.8)	.350	(8.9)	.625	(15.9)	10
41	18	1.093	(27.8)	2.362	(60.0)	1.544	(39.2)	.957	(24.3)	.125	(3.2)	.312	(7.9)	04
42	18	1.093	(27.8)	2.362	(60.0)	1.544	(39.2)	1.145	(29.1)	.250	(6.4)	.437	(11.1)	06
43	20	1.093	(27.8)	2.362	(60.0)	1.544	(39.2)	1.145	(29.1)	.250	(6.4)	.437	(11.1)	06
44	22	1.188	(30.2)	2.512	(63.8)	1.544	(39.2)	.957	(24.3)	.125	(3.2)	.312	(7.9)	04
45	22	1.188	(30.2)	2.512	(63.8)	1.544	(39.2)	1.145	(29.1)	.250	(6.4)	.437	(11.1)	06
46	24	1.188	(30.2)	2.512	(63.8)	1.844	(46.8)	1.332	(33.8)	.350	(8.9)	.625	(15.9)	10
47	36	1.406	(35.7)	2.752	(69.9)	1.916	(48.7)	1.551	(39.4)	.500	(12.7)	.750	(19.1)	12
48	40	2.156	(54.8)	2.752	(69.9)	1.916	(48.7)	1.551	(39.4)	.500	(12.7)	.750	(19.1)	12
49*	10	1.500	(38.1)	1.972	(50.1)	1.544	(39.2)	1.145	(29.1)	.250	(6.4)	.437	(11.1)	06
50*	14	1.842	(46.8)	2.362	(60.0)	1.916	(48.7)	1.551	(39.4)	.500	(12.7)	.750	(19.1)	12
51*	16	1.937	(49.2)	2.512	(63.8)	2.000	(50.8)	1.770	(45.0)	.625	(15.9)	.937	(23.8)	16
52	18	1.093	(27.8)	2.362	(60.0)	1.916	(48.7)	1.551	(39.4)	.500	(12.7)	.750	(19.1)	12
53	61	1.188	(30.2)	2.512	(63.8)	2.000	(50.8)	1.770	(45.0)	.625	(15.9)	.937	(23.8)	16
54	20	1.093	(27.8)	2.362	(60.0)	1.916	(48.7)	1.551	(39.4)	.500	(12.7)	.750	(19.1)	12
55*	20	2.061	(52.3)	2.562	(65.1)	2.230	(56.6)	2.113	(53.7)	.875	(22.2)	1.250	(31.8)	20
56	22	1.188	(30.2)	2.512	(63.8)	1.844	(46.8)	1.332	(33.8)	.350	(8.9)	.625	(15.9)	10
57	22	1.188	(30.2)	2.512	(63.8)	2.000	(50.8)	1.770	(45.0)	.625	(15.9)	.937	(23.8)	16
58*	22	2.061	(52.3)	2.562	(65.1)	2.230	(56.6)	2.113	(53.7)	.875	(22.2)	1.250	(31.8)	20
59	24	1.188	(30.2)	2.512	(63.8)	2.000	(50.8)	1.770	(45.0)	.625	(15.9)	.937	(23.8)	16
60	28	1.313	(33.4)	2.562	(65.1)	1.916	(48.7)	1.551	(39.4)	.500	(12.7)	.750	(19.1)	12
61	28	1.313	(33.4)	2.562	(65.1)	2.230	(56.6)	2.113	(53.7)	.875	(22.2)	1.250	(31.8)	20
62	32	1.375	(34.9)	2.662	(67.6)	2.024	(51.4)	2.363	(60.0)	1.000	(25.4)	1.375	(34.9)	24
63	36	1.406	(35.7)	2.752	(69.9)	2.230	(56.6)	2.113	(53.7)	.875	(22.2)	1.250	(31.8)	20
64	36	1.406	(35.7)	2.752	(69.9)	2.550	(64.8)	2.770	(70.4)	1.250	(31.8)	1.625	(41.3)	28
65	40	2.156	(54.8)	2.752	(69.9)	2.230	(56.6)	2.113	(53.7)	.875	(22.2)	1.250	(31.8)	20
66	40	2.156	(54.8)	2.752	(69.9)	2.550	(64.8)	2.770	(70.4)	1.250	(31.8)	1.625	(41.3)	28
67	44	2.156	(54.8)	2.752	(69.9)	2.230	(56.6)	2.113	(53.7)	.875	(22.2)	1.250	(31.8)	20
68	44	2.156	(54.8)	2.752	(69.9)	2.550	(64.8)	2.770	(70.4)	1.250	(31.8)	1.625	(41.3)	28
69	48	2.156	(54.8)	2.752	(69.9)	2.230	(56.6)	2.113	(53.7)	.875	(22.2)	1.250	(31.8)	20
70	48	2.156	(54.8)	2.752	(69.9)	2.550	(64.8)	2.770	(70.4)	1.250	(31.8)	1.625	(41.3)	28
71*	12	1.654	(42.0)	2.172	(55.2)	1.844	(46.8)	1.332	(33.8)	.350	(8.9)	.625	(15.9)	10
72*	18	1.937	(49.2)	2.512	(63.8)	2.000	(50.8)	1.770	(45.0)	.625	(15.9)	.937	(23.8)	16
73*	24	2.061	(52.3)	2.562	(65.1)	2.230	(56.6)	2.116	(53.7)	.875	(22.2)	1.250	(31.8)	20
74	14	.813	(20.7)	2.062	(52.4)	1.544	(39.2)	.957	(24.3)	.125	(3.2)	.312	(7.9)	04
75	16	.906	(23.0)	2.172	(55.2)	1.544	(39.2)	.957	(24.3)	.125	(3.2)	.312	(7.9)	04

© 2005 Glenair, Inc.

* Denotes Style 2

CAGE Code 06324

Printed in U.S.A.



AS85049/8 and MS3188A EMI/RFI Environmental Backshell

Glenair Connector Designator A

**MIL-DTL-5015 Series 3400,
MIL-DTL-26482 Series 2,
AS81703 Series 3,
MIL-DTL-83723 Series I &
III, 40M39569, DEF 5326-3,
EN 2997, EN 3646,
ESC 10, ESC 11, LN 29504,
NFC93422 Series HE302,
PAN 6432-1, PAN 6432-2,
PATT 602**

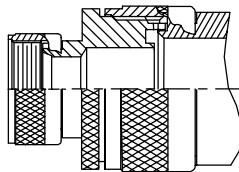

STYLE 2

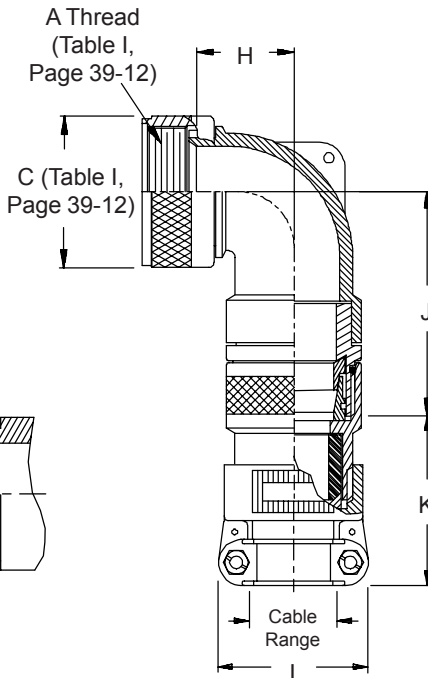

M85049/8-21 W

Basic Part No. _____
Dash No. _____
Finish _____
B = Black Cadmium, Stainless Steel
N = Electroless Nickel, Aluminum
S = Passivated Stainless Steel
W = 1,000 Hour Cad. Olive Drab Over
Electroless Nickel, Aluminum

Superseded Part Number

MS3188A 21 C

Basic Part No. _____
Dash No. _____
Finish (Material is Aluminum Only)
A = Cadmium Olive Drab over Nickel
C = Cadmium Olive Drab
N = Electroless Nickel

1. For complete dimensions see applicable Military Specification.
2. Metric dimensions (mm) are indicated in parentheses.
3. When maximum cable entry is exceeded, Style 2 will be supplied.
4. Cable range is defined as the accommodations range for the wire bundle or cable. Dimensions shown are not intended for inspection criteria.

TABLE II

Dash No.	Shell Size	H		J		K		L		Cable Range				M85049/42 Ref
		Max	(mm)	Max	(mm)	Ref.	(mm)	Max	(mm)	Min	(mm)	Max	(mm)	
1	3	.761	(19.3)	1.862	(47.3)	1.544	(39.2)	.957	(24.3)	.125	(3.2)	.250	(6.4)	4
2	3	1.511	(38.4)	1.382	(35.1)	1.544	(39.2)	1.145	(29.1)	.250	(6.4)	.437	(11.1)	6
3	8	.666	(16.9)	1.262	(32.1)	1.544	(39.2)	.957	(24.3)	.125	(3.2)	.250	(6.4)	4
4	10	.761	(19.3)	1.982	(50.3)	1.544	(39.2)	.957	(24.3)	.125	(3.2)	.312	(7.9)	4
5	10	.761	(19.3)	1.382	(35.1)	1.544	(39.2)	1.145	(29.1)	.250	(6.4)	.375	(9.5)	6
6	12	.766	(19.5)	2.002	(50.9)	1.544	(39.2)	.957	(24.3)	.125	(3.2)	.312	(7.9)	4
7	12	.766	(19.5)	2.002	(50.9)	1.544	(39.2)	1.145	(29.1)	.250	(6.4)	.437	(11.1)	6
8	12	.766	(19.5)	1.397	(35.5)	1.844	(46.8)	1.332	(33.8)	.350	(8.9)	.500	(12.7)	10
9	14	.866	(22.0)	2.072	(52.6)	1.544	(39.2)	1.145	(29.1)	.250	(6.4)	.437	(11.1)	6
10	14	.866	(22.0)	1.717	(43.6)	1.844	(46.8)	1.332	(33.8)	.350	(8.9)	.575	(14.6)	10
11	16	1.051	(26.7)	2.162	(54.9)	1.544	(39.2)	1.145	(29.1)	.250	(6.4)	.437	(11.1)	6
12	16	1.051	(26.7)	1.807	(45.9)	1.916	(48.7)	1.551	(39.4)	.500	(12.7)	.700	(17.8)	12
13	18	1.141	(29.0)	2.332	(59.2)	1.844	(46.8)	1.332	(33.8)	.350	(8.9)	.625	(15.9)	10
14	18	1.141	(29.0)	1.982	(50.3)	2.000	(50.8)	1.770	(45.0)	.625	(15.9)	.779	(19.8)	16
15	20	1.141	(29.0)	2.332	(59.2)	1.844	(46.8)	1.332	(33.8)	.350	(8.9)	.625	(15.9)	10
16	20	1.141	(29.0)	1.982	(50.3)	2.000	(50.8)	1.770	(45.0)	.625	(15.9)	.904	(23.0)	16
17	22	1.291	(32.8)	2.442	(62.0)	1.916	(48.7)	1.551	(39.4)	.500	(12.7)	.750	(19.1)	12
18	22	1.291	(32.8)	2.087	(53.0)	2.230	(56.6)	2.113	(53.7)	.875	(22.2)	1.029	(26.1)	20
19	24	1.291	(32.8)	2.442	(62.0)	1.916	(48.7)	1.551	(39.4)	.500	(12.7)	.750	(19.1)	12
20	24	1.291	(32.8)	2.087	(53.0)	2.230	(56.6)	2.113	(53.7)	.875	(22.2)	1.144	(29.1)	20
21	28	1.391	(35.3)	2.612	(66.3)	2.000	(50.8)	1.770	(45.0)	.625	(15.9)	.937	(23.8)	16

Table II Continued on Page 39-11

AS85049/8 and MS3188A
EMI/RFI Environmental Backshell



EMI/RFI
Environmental
Backshells

TABLE II (Continued From Page 39-10)

Dash No.	Shell Size	H		J		K Ref.	L		Cable Range		M85049/42 Ref			
		Max	()	Max	()		Max	()	Min	Max				
22	28	1.391	(35.3)	2.257	(57.3)	2.024	(51.4)	2.363	(60.0)	1.000	(25.4)	1.375	(34.9)	24
23	32	1.741	(44.2)	2.862	(72.7)	2.000	(50.8)	1.770	(45.0)	.625	(15.9)	.937	(23.8)	16
24	32	1.741	(44.2)	2.862	(72.7)	2.230	(56.6)	2.113	(53.7)	.875	(22.2)	1.250	(31.8)	20
25	32	1.741	(44.2)	2.507	(63.7)	2.550	(64.8)	2.770	(70.4)	1.250	(31.8)	1.625	(41.3)	28
26	36	1.941	(49.3)	2.832	(71.9)	2.000	(50.8)	1.770	(45.0)	.625	(15.9)	.937	(23.8)	16
27	36	1.941	(49.3)	2.832	(71.9)	2.024	(51.4)	2.363	(60.0)	1.000	(25.4)	1.375	(34.9)	24
28	36	1.941	(49.3)	2.477	(62.9)	2.600	(66.0)	3.020	(76.7)	1.437	(36.5)	1.840	(46.7)	32
29	40	2.691	(68.4)	2.832	(71.9)	2.000	(50.8)	1.770	(45.0)	.625	(15.9)	.937	(23.8)	16
30	40	2.691	(68.4)	2.832	(71.9)	2.024	(51.4)	2.363	(60.0)	1.000	(25.4)	1.375	(34.9)	24
31	40	2.691	(68.4)	2.477	(62.9)	2.600	(66.0)	3.020	(76.7)	1.437	(36.5)	1.875	(47.6)	32
32	44	2.691	(68.4)	2.832	(71.9)	2.000	(50.8)	1.770	(45.0)	.625	(15.9)	.937	(23.8)	16
33	44	2.691	(68.4)	2.832	(71.9)	2.024	(51.4)	2.363	(60.0)	1.000	(25.4)	1.375	(34.9)	24
34	44	2.691	(68.4)	2.477	(62.9)	2.600	(66.0)	3.020	(76.7)	1.437	(36.5)	1.875	(47.6)	32
35	48	2.691	(68.4)	2.832	(71.9)	2.000	(50.8)	1.770	(45.0)	.625	(15.9)	.937	(23.8)	16
36	48	2.691	(68.4)	2.832	(71.9)	2.024	(51.4)	2.363	(60.0)	1.000	(25.4)	1.375	(34.9)	24
37	48	2.691	(68.4)	2.477	(62.9)	2.600	(66.0)	3.020	(76.7)	1.437	(36.5)	1.875	(47.6)	32
38	61	1.291	(32.8)	2.442	(62.0)	1.916	(48.7)	1.551	(39.4)	.500	(12.7)	.750	(19.1)	12
39	61	1.291	(32.8)	2.087	(53.0)	2.230	(56.6)	2.113	(53.7)	.875	(22.2)	1.184	(30.1)	20
40	16	1.051	(26.7)	2.162	(54.9)	1.844	(46.8)	1.332	(33.8)	.350	(8.9)	.625	(15.9)	10
41	18	1.141	(29.0)	2.332	(59.2)	1.544	(39.2)	.957	(24.3)	.125	(3.2)	.312	(7.9)	4
42	18	1.141	(29.0)	2.332	(59.2)	1.544	(39.2)	1.145	(29.1)	.250	(6.4)	.437	(11.1)	6
43	20	1.141	(29.0)	2.332	(59.2)	1.544	(39.2)	1.145	(29.1)	.250	(6.4)	.437	(11.1)	6
44	22	1.291	(32.8)	2.442	(62.0)	1.544	(39.2)	.957	(24.3)	.125	(3.2)	.312	(7.9)	4
45	22	1.291	(32.8)	2.442	(62.0)	1.544	(39.2)	1.145	(29.1)	.250	(6.4)	.437	(11.1)	6
46	24	1.291	(32.8)	2.442	(62.0)	1.844	(46.8)	1.332	(33.8)	.350	(8.9)	.625	(15.9)	10
47	36	1.941	(49.3)	2.832	(71.9)	1.916	(48.7)	1.551	(39.4)	.500	(12.7)	.750	(19.1)	12
48	40	1.941	(49.3)	2.832	(71.9)	1.916	(48.7)	1.551	(39.4)	.500	(12.7)	.750	(19.1)	12
49*	10	1.516	(38.5)	2.002	(50.9)	1.544	(39.2)	1.145	(29.1)	.250	(6.4)	.437	(11.1)	6
50*	14	1.891	(48.0)	2.332	(59.2)	1.916	(48.7)	1.551	(39.4)	.500	(12.7)	.750	(19.1)	12
51*	16	2.041	(51.8)	2.442	(62.0)	2.000	(50.8)	1.770	(45.0)	.625	(15.9)	.937	(23.8)	16
52	18	1.141	(29.0)	2.332	(59.2)	1.916	(48.7)	1.551	(39.4)	.500	(12.7)	.750	(19.1)	12
53	61	1.291	(32.8)	2.087	(53.0)	2.000	(50.8)	1.770	(45.0)	.625	(15.9)	.937	(23.8)	16
54	20	1.141	(29.0)	2.332	(59.2)	1.916	(48.7)	1.551	(39.4)	.500	(12.7)	.750	(19.1)	12
55*	20	2.141	(54.4)	2.612	(66.3)	2.230	(56.6)	2.113	(53.7)	.875	(22.2)	1.250	(31.8)	20
56	22	1.291	(32.8)	2.442	(62.0)	1.844	(46.8)	1.332	(33.8)	.350	(8.9)	.625	(15.9)	10
57	22	1.291	(32.8)	2.442	(62.0)	2.000	(50.8)	1.770	(45.0)	.625	(15.9)	.937	(23.8)	16
58*	22	2.141	(54.4)	2.612	(66.3)	2.230	(56.6)	2.113	(53.7)	.875	(22.2)	1.250	(31.8)	20
59	24	1.291	(32.8)	2.442	(62.0)	2.000	(50.8)	1.770	(45.0)	.625	(15.9)	.937	(23.8)	16
60	28	1.391	(35.3)	2.612	(66.3)	1.916	(48.7)	1.551	(39.4)	.500	(12.7)	.750	(19.1)	12
61	28	1.391	(35.3)	2.612	(66.3)	2.230	(56.6)	2.113	(53.7)	.875	(22.2)	1.250	(31.8)	20
62	32	1.741	(44.2)	2.862	(72.7)	2.024	(51.4)	2.363	(60.0)	1.000	(25.4)	1.375	(34.9)	24
63	36	1.941	(49.3)	2.832	(71.9)	2.230	(56.6)	2.113	(53.7)	.875	(22.2)	1.250	(31.8)	20
64	36	1.941	(49.3)	2.832	(71.9)	2.550	(64.8)	2.770	(70.4)	1.250	(31.8)	1.625	(41.3)	28
65	40	2.691	(68.4)	2.832	(71.9)	2.230	(56.6)	2.113	(53.7)	.875	(22.2)	1.250	(31.8)	20
66	40	2.691	(68.4)	2.832	(71.9)	2.550	(64.8)	2.770	(70.4)	1.250	(31.8)	1.625	(41.3)	28
67	44	2.691	(68.4)	2.832	(71.9)	2.230	(56.6)	2.113	(53.7)	.875	(22.2)	1.250	(31.8)	20
68	44	2.691	(68.4)	2.832	(71.9)	2.550	(64.8)	2.770	(70.4)	1.250	(31.8)	1.625	(41.3)	28
69	48	2.691	(68.4)	2.832	(71.9)	2.230	(56.6)	2.113	(53.7)	.875	(22.2)	1.250	(31.8)	20
70	48	2.691	(68.4)	2.832	(71.9)	2.550	(64.8)	2.770	(70.4)	1.250	(31.8)	1.625	(41.3)	28
71*	12	1.811	(46.0)	2.162	(54.9)	1.844	(46.8)	1.332	(33.8)	.350	(8.9)	.625	(15.9)	10
72*	18	2.051	(52.1)	2.442	(62.0)	2.000	(50.8)	1.770	(45.0)	.625	(15.9)	.937	(23.8)	16
73*	24	2.151	(54.6)	2.612	(66.3)	2.230	(56.6)	2.116	(53.7)	.875	(22.2)	1.250	(31.8)	20
74	14	.866	(22.0)	2.072	(52.6)	1.544	(39.2)	.957	(24.3)	.125	(3.2)	.312	(7.9)	4
75	16	1.051	(26.7)	2.162	(54.9)	1.544	(39.2)	.957	(24.3)	.125	(3.2)	.312	(7.9)	4

* Denotes Style 2

1. For complete dimensions see applicable Military Specification.
2. Metric dimensions (mm) are indicated in parentheses.
3. When maximum cable entry is exceeded, Style 2 will be supplied.
4. Cable range is defined as the accommodations range for the wire bundle or cable. Dimensions shown are not intended for inspection criteria.

© 2005 Glenair, Inc.

CAGE Code 06324

Printed in U.S.A.

AS85049/10 and MS3437A EMI/RFI Environmental Backshell

Glenair Connector Designator A

MIL-DTL-5015 Series 3400,
MIL-DTL-26482 Series 2,
AS81703 Series 3,
MIL-DTL-83723 Series I &
III, 40M39569, DEF 5326-3,
EN 2997, EN 3646,
ESC 10, ESC 11, LN 29504,
NFC93422 Series HE302,
PAN 6432-1, PAN 6432-2,
PATT 602

M85049/10-21 W

Basic Part No. _____
Dash No. (Table II) _____

Finish
B = Black Cadmium, Stainless Steel
N = Electroless Nickel, Aluminum
S = Passivated Stainless Steel
W = 1,000 Hour Cad. Olive Drab Over Electroless Nickel, Aluminum

MS3437A 21 C

Basic Part No. _____
Dash No. (Table II) _____

Finish (Material is Aluminum Only)
A = Cadmium Olive Drab over Nickel
C = Cadmium Olive Drab
N = Electroless Nickel

Superseded Part Number

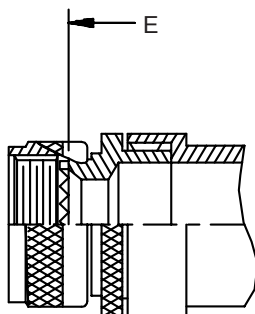

STYLE 2

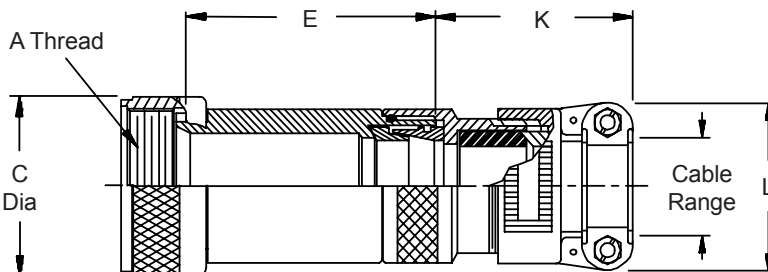

STYLE 1

TABLE I

Shell Size	A Thread Class 2B	C Dia Max
3	.562 - 24 UNEF	.67 (17.0)
8	.500 - 20 UNF	.62 (15.7)
10	.625 - 24 UNEF	.73 (18.5)
12	.750 - 20 UNEF	.86 (21.8)
14	.875 - 20 UNEF	.98 (24.9)
16	1.000 - 20 UNEF	1.11 (28.2)
18	1.062 - 18 UNEF	1.22 (31.0)
20	1.188 - 18 UNEF	1.34 (34.0)
22	1.313 - 18 UNEF	1.47 (37.3)
24	1.438 - 18 UNEF	1.59 (40.4)
28	1.750 - 18 UNS	1.97 (50.0)
32	2.000 - 18 UNS	2.22 (56.4)
36	2.250 - 16 UN	2.47 (62.7)
40	2.500 - 16 UN	2.72 (69.1)
44	2.750 - 16 UN	2.97 (75.4)
48	3.000 - 16 UN	3.22 (81.8)
61	1.500 - 18 UNEF	1.65 (41.9)

1. For complete dimensions see applicable Military Specification.
2. Metric dimensions (mm) are indicated in parentheses.
3. When maximum cable entry is exceeded, Style 2 will be supplied.
4. Cable range is defined as the accommodations range for the wire bundle or cable. Dimensions shown are not intended for inspection criteria.

AS85049/10 and MS3437A
EMI/RFI Environmental Backshell



EMI/RFI
Environmental
Backshells

TABLE II

Dash No.	Shell Size	Style	E		K		L		Cable Range		M85049/42		
			Max	(Inches)	Ref.	(Inches)	Max	(Inches)	Min	Max	Ref		
01	3	1	2.125	(54.0)	1.544	(39.2)	.957	(24.3)	.125	(3.2)	.250	(6.4)	4
02	3	1	3.125	(79.4)	1.544	(39.2)	.957	(24.3)	.125	(3.2)	.250	(6.4)	4
03	3	2	2.875	(73.0)	1.544	(39.2)	1.145	(29.1)	.250	(6.4)	.437	(11.1)	6
04	3	2	3.875	(98.4)	1.544	(39.2)	1.145	(29.1)	.250	(6.4)	.437	(11.1)	6
05	8	1	2.125	(54.0)	1.544	(39.2)	.957	(24.3)	.125	(3.2)	.250	(6.4)	4
06	8	1	3.125	(79.4)	1.544	(39.2)	.957	(24.3)	.125	(3.2)	.250	(6.4)	4
07	8	2	2.875	(73.0)	1.544	(39.2)	1.145	(29.1)	.250	(6.4)	.437	(11.1)	6
08	8	2	3.875	(98.4)	1.544	(39.2)	1.145	(29.1)	.250	(6.4)	.437	(11.1)	6
09	10	1	2.125	(54.0)	1.544	(39.2)	.957	(24.3)	.125	(3.2)	.312	(7.9)	4
10	10	1	3.125	(79.4)	1.544	(39.2)	.957	(24.3)	.125	(3.2)	.312	(7.9)	4
11	10	2	2.875	(73.0)	1.544	(39.2)	1.145	(29.1)	.250	(6.4)	.437	(11.1)	6
12	10	2	3.875	(98.4)	1.544	(39.2)	1.145	(29.1)	.250	(6.4)	.437	(11.1)	6
13	12	1	2.125	(54.0)	1.544	(39.2)	1.145	(29.1)	.250	(6.4)	.437	(11.1)	6
14	12	1	3.125	(79.4)	1.544	(39.2)	1.145	(29.1)	.250	(6.4)	.437	(11.1)	6
15	12	2	2.875	(73.0)	1.844	(46.8)	1.332	(33.8)	.350	(8.9)	.625	(15.9)	10
16	12	2	3.875	(98.4)	1.844	(46.8)	1.332	(33.8)	.350	(8.9)	.625	(15.9)	10
17	14	1	2.125	(54.0)	1.844	(46.8)	1.332	(33.8)	.350	(8.9)	.575	(14.6)	10
18	14	1	3.125	(79.4)	1.844	(46.8)	1.332	(33.8)	.350	(8.9)	.575	(14.6)	10
19	14	2	2.875	(73.0)	1.916	(48.7)	1.551	(39.4)	.500	(12.7)	.750	(19.1)	12
20	14	2	3.875	(98.4)	1.916	(48.7)	1.551	(39.4)	.500	(12.7)	.750	(19.1)	12
21	16	1	2.125	(54.0)	1.916	(48.7)	1.551	(39.4)	.500	(12.7)	.700	(17.8)	12
22	16	1	3.125	(79.4)	1.916	(48.7)	1.551	(39.4)	.500	(12.7)	.700	(17.8)	12
23	16	2	2.875	(73.0)	2.000	(50.8)	1.770	(45.0)	.625	(15.9)	.937	(23.8)	16
24	16	2	3.875	(98.4)	2.000	(50.8)	1.770	(45.0)	.625	(15.9)	.937	(23.8)	16
25	18	1	2.125	(54.0)	1.844	(46.8)	1.332	(33.8)	.350	(8.9)	.625	(15.9)	10
26	18	1	3.125	(79.4)	1.844	(46.8)	1.332	(33.8)	.350	(8.9)	.625	(15.9)	10
27	18	1	2.125	(54.0)	1.916	(48.7)	1.551	(39.4)	.500	(12.7)	.750	(19.1)	12
28	18	1	3.125	(79.4)	1.916	(48.7)	1.551	(39.4)	.500	(12.7)	.750	(19.1)	12
29	18	2	2.875	(73.0)	2.000	(50.8)	1.770	(45.0)	.625	(15.9)	.937	(23.8)	16
30	18	2	3.875	(98.4)	2.000	(50.8)	1.770	(45.0)	.625	(15.9)	.937	(23.8)	16
31	20	1	3.125	(79.4)	1.844	(46.8)	1.332	(33.8)	.350	(8.9)	.625	(15.9)	10
32	20	1	4.125	(104.8)	1.844	(46.8)	1.332	(33.8)	.350	(8.9)	.625	(15.9)	10
33	20	1	3.125	(79.4)	1.916	(48.7)	1.551	(39.4)	.500	(12.7)	.750	(19.1)	12
34	20	1	4.125	(104.8)	1.916	(48.7)	1.551	(39.4)	.500	(12.7)	.750	(19.1)	12
35	20	2	3.875	(98.4)	2.000	(50.8)	1.770	(45.0)	.625	(15.9)	.937	(23.8)	16
36	20	2	4.875	(123.8)	2.000	(50.8)	1.770	(45.0)	.625	(15.9)	.937	(23.8)	16
37	20	2	3.875	(98.4)	2.230	(56.6)	2.113	(53.7)	.875	(22.2)	1.250	(31.8)	20
38	20	2	4.875	(123.8)	2.230	(56.6)	2.113	(53.7)	.875	(22.2)	1.250	(31.8)	20
39	22	1	3.125	(79.4)	1.844	(46.8)	1.332	(33.8)	.350	(8.9)	.625	(15.9)	10
40	22	1	4.125	(104.8)	1.844	(46.8)	1.332	(33.8)	.350	(8.9)	.625	(15.9)	10
41	22	1	3.125	(79.4)	1.916	(48.7)	1.551	(39.4)	.500	(12.7)	.750	(19.1)	12
42	22	1	4.125	(104.8)	1.916	(48.7)	1.551	(39.4)	.500	(12.7)	.750	(19.1)	12
43	22	1	3.125	(79.4)	2.000	(50.8)	1.770	(45.0)	.625	(15.9)	.937	(23.8)	16
44	22	1	4.125	(104.8)	2.000	(50.8)	1.770	(45.0)	.625	(15.9)	.937	(23.8)	16
45	22	2	3.875	(98.4)	2.230	(56.6)	2.113	(53.7)	.875	(22.2)	1.250	(31.8)	20
46	22	2	4.875	(123.8)	2.230	(56.6)	2.113	(53.7)	.875	(22.2)	1.250	(31.8)	20
47	24	1	3.125	(79.4)	1.916	(48.7)	1.551	(39.4)	.500	(12.7)	.750	(19.1)	12
48	24	1	4.125	(104.8)	1.916	(48.7)	1.551	(39.4)	.500	(12.7)	.750	(19.1)	12
49	24	1	3.125	(79.4)	2.000	(50.8)	1.770	(45.0)	.625	(15.9)	.812	(20.6)	16
50	24	1	4.125	(104.8)	2.000	(50.8)	1.770	(45.0)	.625	(15.9)	.812	(20.6)	16
51	24	1	3.125	(79.4)	2.000	(50.8)	1.770	(45.0)	.625	(15.9)	.937	(23.8)	16
52	24	1	4.125	(104.8)	2.000	(50.8)	1.770	(45.0)	.625	(15.9)	.937	(23.8)	16

Table II Continued on Page 39-14



**AS85049/10 and MS3437A
EMI/RFI Environmental Backshell**

TABLE II (Continued From Page 39-13)

Dash No.	Shell Size	Style	E		K		L		Cable Range			M85049/42 Ref	
			Max		Ref.		Max		Min		Max		
53	24	2	3.875	(98.4)	2.230	(56.6)	2.113	(53.7)	.875	(22.2)	1.250	(31.8)	20
54	24	2	4.875	(123.8)	2.230	(56.6)	2.113	(53.7)	.875	(22.2)	1.250	(31.8)	20
55	28	1	3.125	(79.4)	1.916	(48.7)	1.551	(39.4)	.500	(12.7)	.750	(19.1)	12
56	28	1	4.125	(104.8)	1.916	(48.7)	1.551	(39.4)	.500	(12.7)	.750	(19.1)	12
57	28	1	3.125	(79.4)	2.000	(50.8)	1.770	(45.0)	.625	(15.9)	.937	(23.8)	16
58	28	1	4.125	(104.8)	2.000	(50.8)	1.770	(45.0)	.625	(15.9)	.937	(23.8)	16
59	28	1	3.125	(79.4)	2.230	(56.6)	2.113	(53.7)	.875	(22.2)	1.250	(31.8)	20
60	28	1	4.125	(104.8)	2.230	(56.6)	2.113	(53.7)	.875	(22.2)	1.250	(31.8)	20
61	28	1	3.125	(79.4)	2.024	(51.4)	2.363	(60.0)	1.000	(25.4)	1.375	(34.9)	24
62	28	1	4.126	(104.8)	2.024	(51.4)	2.363	(60.0)	1.000	(25.4)	1.375	(34.9)	24
63	32	1	3.125	(79.4)	2.000	(50.8)	1.770	(45.0)	.625	(15.9)	.937	(23.8)	16
64	32	1	4.125	(104.8)	2.000	(50.8)	1.770	(45.0)	.625	(15.9)	.937	(23.8)	16
65	32	1	3.125	(79.4)	2.230	(56.6)	2.113	(53.7)	.875	(22.2)	1.250	(31.8)	20
66	32	1	4.125	(104.8)	2.230	(56.6)	2.113	(53.7)	.875	(22.2)	1.250	(31.8)	20
67	32	1	3.125	(79.4)	2.024	(51.4)	2.363	(60.0)	1.000	(25.4)	1.375	(34.9)	24
68	32	1	4.125	(104.8)	2.024	(51.4)	2.363	(60.0)	1.000	(25.4)	1.375	(34.9)	24
69	32	1	3.125	(79.4)	2.550	(64.8)	2.770	(70.4)	1.250	(31.8)	1.625	(41.3)	28
70	32	1	4.125	(104.8)	2.550	(64.8)	2.770	(70.4)	1.250	(31.8)	1.625	(41.3)	28
71	36	1	4.125	(104.8)	2.230	(56.6)	2.113	(53.7)	.875	(22.2)	1.250	(31.8)	20
72	36	1	5.125	(130.2)	2.230	(56.6)	2.113	(53.7)	.875	(22.2)	1.250	(31.8)	20
73	36	1	4.125	(104.8)	2.024	(51.4)	2.363	(60.0)	1.000	(25.4)	1.375	(34.9)	24
74	36	1	5.125	(130.2)	2.024	(51.4)	2.363	(60.0)	1.000	(25.4)	1.375	(34.9)	24
75	36	1	4.125	(104.8)	2.550	(64.8)	2.770	(70.4)	1.250	(31.8)	1.625	(41.3)	28
76	36	1	5.125	(130.2)	2.550	(64.8)	2.770	(70.4)	1.250	(31.8)	1.625	(41.3)	28
77	36	2	5.000	(127.0)	2.600	(66.0)	3.020	(76.7)	1.437	(36.5)	1.875	(47.6)	32
78	36	2	6.000	(152.4)	2.600	(66.0)	3.020	(76.7)	1.437	(36.5)	1.875	(47.6)	32
79	40	1	4.125	(104.8)	2.230	(56.6)	2.113	(53.7)	.875	(22.2)	1.250	(31.8)	20
80	40	1	5.125	(130.2)	2.230	(56.6)	2.113	(53.7)	.875	(22.2)	1.250	(31.8)	20
81	40	1	4.125	(104.8)	2.024	(51.4)	2.363	(60.0)	1.000	(25.4)	1.375	(34.9)	24
82	40	1	5.125	(130.2)	2.024	(51.4)	2.363	(60.0)	1.000	(25.4)	1.375	(34.9)	24
83	40	1	4.125	(104.8)	2.550	(64.8)	2.770	(70.4)	1.250	(31.8)	1.625	(41.3)	28
84	40	1	5.125	(130.2)	2.550	(64.8)	2.770	(70.4)	1.250	(31.8)	1.625	(41.3)	28
85	40	1	4.125	(104.8)	2.600	(66.0)	3.020	(76.7)	1.437	(36.5)	1.875	(47.6)	32
86	40	1	5.125	(130.2)	2.600	(66.0)	3.020	(76.7)	1.437	(36.5)	1.875	(47.6)	32
87	44	1	4.125	(104.8)	2.230	(56.6)	2.113	(53.7)	.875	(22.2)	1.250	(31.8)	20
88	44	1	5.125	(130.2)	2.230	(56.6)	2.113	(53.7)	.875	(22.2)	1.250	(31.8)	20
89	44	1	4.125	(104.8)	2.024	(51.4)	2.363	(60.0)	1.000	(25.4)	1.375	(34.9)	24
90	44	1	5.125	(130.2)	2.024	(51.4)	2.363	(60.0)	1.000	(25.4)	1.375	(34.9)	24
91	44	1	4.125	(104.8)	2.550	(64.8)	2.770	(70.4)	1.250	(31.8)	1.625	(41.3)	28
92	44	1	5.125	(130.2)	2.550	(64.8)	2.770	(70.4)	1.250	(31.8)	1.625	(41.3)	28
93	44	1	4.125	(104.8)	2.600	(66.0)	3.020	(76.7)	1.437	(36.5)	1.875	(47.6)	32
94	44	1	5.125	(130.2)	2.600	(66.0)	3.020	(76.7)	1.437	(36.5)	1.875	(47.6)	32
95	48	1	4.125	(104.8)	2.230	(56.6)	2.113	(53.7)	.875	(22.2)	1.250	(31.8)	20
96	48	1	5.125	(130.2)	2.230	(56.6)	2.113	(53.7)	.875	(22.2)	1.250	(31.8)	20
97	48	1	4.125	(104.8)	2.024	(51.4)	2.363	(60.0)	1.000	(25.4)	1.375	(34.9)	24
98	48	1	5.125	(130.2)	2.024	(51.4)	2.363	(60.0)	1.000	(25.4)	1.375	(34.9)	24
99	48	1	4.125	(104.8)	2.550	(64.8)	2.770	(70.4)	1.250	(31.8)	1.625	(41.3)	28
100	48	1	5.125	(130.2)	2.550	(64.8)	2.770	(70.4)	1.250	(31.8)	1.625	(41.3)	28
101	48	1	4.125	(104.8)	2.600	(66.0)	3.020	(76.7)	1.437	(36.5)	1.875	(47.6)	32
102	48	1	5.125	(130.2)	2.600	(66.0)	3.020	(76.7)	1.437	(36.5)	1.875	(47.6)	32
103	61	1	3.125	(79.4)	1.916	(48.7)	1.551	(39.4)	.500	(12.7)	.750	(19.1)	12
104	61	1	4.125	(104.8)	1.916	(48.7)	1.551	(39.4)	.500	(12.7)	.750	(19.1)	12

Table II Continued on Page 39-15

AS85049/10 and MS3437A
EMI/RFI Environmental Backshell



EMI/RFI
Environmental
Backshells

TABLE II (Continued From Page 39-14)

Dash No.	Shell Size	Style	E		K		L		Cable Range		M85049/42 Ref		
			Max	(in)	Ref.	(in)	Max	(in)	Min	Max			
105	61	1	3.125	(79.4)	2.000	(50.8)	1.770	(45.0)	.625	(15.9)	.937	(23.8)	16
106	61	1	4.125	(104.8)	2.000	(50.8)	1.770	(45.0)	.625	(15.9)	.937	(23.8)	16
107	61	2	3.875	(98.4)	2.230	(56.6)	2.113	(53.7)	.875	(22.2)	1.250	(31.8)	20
108	61	2	4.875	(123.8)	2.230	(56.6)	2.113	(53.7)	.875	(22.2)	1.250	(31.8)	20
109	61	2	3.875	(98.4)	2.024	(51.4)	2.363	(60.0)	1.000	(25.4)	1.375	(34.9)	24
110	61	2	4.875	(123.8)	2.024	(51.4)	2.363	(60.0)	1.000	(25.4)	1.375	(34.9)	24
111	12	1	2.125	(54.0)	1.844	(46.8)	1.332	(33.8)	.350	(8.9)	.500	(12.7)	10
112	16	1	2.125	(54.0)	1.544	(39.2)	1.145	(29.1)	.250	(6.4)	.437	(11.1)	6
113	16	1	3.125	(79.4)	1.544	(39.2)	1.145	(29.1)	.250	(6.4)	.437	(11.1)	6
114	12	1	2.125	(54.0)	1.544	(39.2)	.957	(24.3)	.125	(3.2)	.312	(7.9)	4
115	12	1	3.125	(79.4)	1.544	(39.2)	.957	(24.3)	.125	(3.2)	.312	(7.9)	4
116	14	1	2.125	(54.0)	1.544	(39.2)	1.145	(29.1)	.250	(6.4)	.437	(11.1)	6
117	14	1	3.125	(79.4)	1.544	(39.2)	1.145	(29.1)	.250	(6.4)	.437	(11.1)	6
118	16	1	2.125	(54.0)	1.844	(46.8)	1.332	(33.8)	.350	(8.9)	.625	(15.9)	10
119	16	1	3.125	(79.4)	1.844	(46.8)	1.332	(33.8)	.350	(8.9)	.625	(15.9)	10
120	18	1	2.125	(54.0)	1.544	(39.2)	.957	(24.3)	.125	(3.2)	.312	(7.9)	4
121	18	1	3.125	(79.4)	1.544	(39.2)	.957	(24.3)	.125	(3.2)	.312	(7.9)	4
122	18	1	2.125	(54.0)	1.544	(39.2)	1.145	(29.1)	.250	(6.4)	.437	(11.1)	6
123	18	1	3.125	(79.4)	1.544	(39.2)	1.145	(29.1)	.250	(6.4)	.437	(11.1)	6
124	20	1	3.125	(79.4)	1.544	(39.2)	1.145	(29.1)	.250	(6.4)	.437	(11.1)	6
125	20	1	4.125	(104.8)	1.544	(39.2)	1.145	(29.1)	.250	(6.4)	.437	(11.1)	6
126	22	1	3.125	(79.4)	1.544	(39.2)	.957	(24.3)	.125	(3.2)	.312	(7.9)	4
127	22	1	4.125	(104.8)	1.544	(39.2)	.957	(24.3)	.125	(3.2)	.312	(7.9)	4
128	22	1	3.125	(79.4)	1.544	(39.2)	1.145	(29.1)	.250	(6.4)	.437	(11.1)	6
129	22	1	4.125	(104.8)	1.544	(39.2)	1.145	(29.1)	.250	(6.4)	.437	(11.1)	6
130	24	1	3.125	(79.4)	1.844	(46.8)	1.332	(33.8)	.350	(8.9)	.625	(15.9)	10
131	24	1	4.125	(104.8)	1.844	(46.8)	1.332	(33.8)	.350	(8.9)	.625	(15.9)	10
132	36	1	4.125	(104.8)	1.916	(48.7)	1.551	(39.4)	.500	(12.7)	.750	(19.1)	12
133	36	1	5.125	(130.2)	1.916	(48.7)	1.551	(39.4)	.500	(12.7)	.750	(19.1)	12
134	40	1	4.125	(104.8)	1.916	(48.7)	1.551	(39.4)	.500	(12.7)	.750	(19.1)	12
135	40	1	5.125	(130.2)	1.916	(48.7)	1.551	(39.4)	.500	(12.7)	.750	(19.1)	12
136	10	1	2.125	(54.0)	1.544	(39.2)	1.145	(29.1)	.250	(6.4)	.375	(9.5)	6
137	10	1	3.125	(79.4)	1.544	(39.2)	1.145	(29.1)	.250	(6.4)	.375	(9.5)	6
138	12	1	2.125	(54.0)	1.844	(46.8)	1.332	(33.8)	.350	(8.9)	.500	(12.7)	10
139	12	1	3.125	(79.4)	1.844	(46.8)	1.332	(33.8)	.350	(8.9)	.500	(12.7)	10
140	20	1	3.125	(79.4)	2.000	(50.8)	1.770	(45.0)	.625	(15.9)	.904	(23.0)	16
141	20	1	4.125	(104.8)	2.000	(50.8)	1.770	(45.0)	.625	(15.9)	.904	(23.0)	16
142	22	1	3.125	(79.4)	2.230	(56.6)	2.113	(53.7)	.875	(22.2)	1.029	(26.1)	20
143	22	1	4.125	(104.8)	2.230	(56.6)	2.113	(53.7)	.875	(22.2)	1.029	(26.1)	20
144	24	1	3.125	(79.4)	2.230	(56.6)	2.113	(53.7)	.875	(22.2)	1.144	(29.1)	20
145	24	1	4.125	(104.8)	2.230	(56.6)	2.113	(53.7)	.875	(22.2)	1.144	(29.1)	20
146	36	1	4.125	(104.8)	2.600	(66.0)	3.020	(76.7)	1.437	(36.5)	1.840	(46.7)	32
147	36	1	5.125	(130.2)	2.600	(66.0)	3.020	(76.7)	1.437	(36.5)	1.840	(46.7)	32
148	36	1	4.125	(104.8)	2.000	(50.8)	1.770	(45.0)	.625	(15.9)	.937	(23.8)	16
149	36	1	5.125	(130.2)	2.000	(50.8)	1.770	(45.0)	.625	(15.9)	.937	(23.8)	16
150	14	1	2.125	(54.0)	1.544	(39.2)	.957	(24.3)	.125	(3.2)	.312	(7.9)	4
151	14	1	3.125	(79.4)	1.544	(39.2)	.957	(24.3)	.125	(3.2)	.312	(7.9)	4
152	16	1	2.125	(54.0)	1.544	(39.2)	.957	(24.3)	.125	(3.2)	.312	(7.9)	4
153	16	1	3.125	(79.4)	1.544	(39.2)	.957	(24.3)	.125	(3.2)	.312	(7.9)	4
154	44	1	4.125	(104.8)	2.000	(50.8)	1.770	(45.0)	.625	(15.9)	.937	(23.8)	16
155	44	1	5.125	(130.2)	2.000	(50.8)	1.770	(45.0)	.625	(15.9)	.937	(23.8)	16
156	40	1	4.125	(104.8)	2.000	(50.8)	1.770	(45.0)	.625	(15.9)	.937	(23.8)	16
157	40	1	5.125	(130.2)	2.000	(50.8)	1.770	(45.0)	.625	(15.9)	.937	(23.8)	16



AS85049/17 EMI/RFI Environmental Backshell

Glenair Connector Designator F

MIL-DTL-38999 Series I & II, 40M38277, PAN 6433-1, PATT 614, PATT 616, NFC93422 Series HE308 & HE309

M85049/17 10 N 03 A

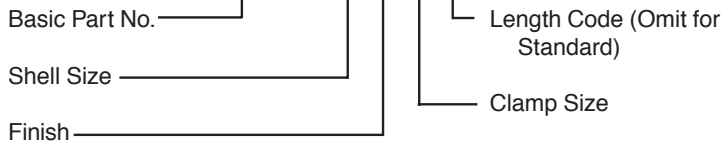

N = Electroless Nickel
W = 1,000 Hr. Cadmium Olive Drab Over Electroless Nickel

Shell Size	A Thread Class 2B	B Dia Max
08	.438 - 28 UNEF	.57 (14.5)
10	.562 - 24 UNEF	.70 (17.8)
12	.688 - 24 UNEF	.83 (21.1)
14	.813 - 20 UNEF	.95 (24.1)
16	.938 - 20 UNEF	1.08 (27.4)
18	1.063 - 18 UNEF	1.20 (30.5)
20	1.188 - 18 UNEF	1.33 (33.8)
22	1.313 - 18 UNEF	1.45 (36.8)
24	1.438 - 18 UNEF	1.58 (40.1)

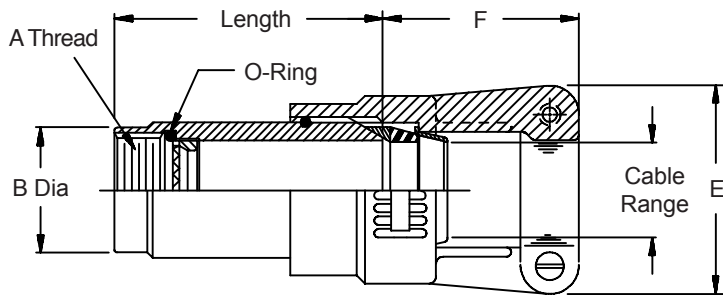

Shell Size	Shell Size Series 1		Clamp Size	
	Ref.	Min	Max	
08	9	01	02	
10	11	01	03	
12	13	02	04	
14	15	02	05	
16	17	02	06	
18	19	03	07	
20	21	03	08	
22	23	03	09	
24	25	04	10	

Clamp Size	Cable Range		E Max	F Max
	Min	Max		
01	.062 (1.6)	.125 (3.2)	.781 (19.8)	1.250 (31.8)
02	.125 (3.2)	.250 (6.4)	.969 (24.6)	1.250 (31.8)
03	.250 (6.4)	.375 (9.5)	1.062 (27.0)	1.250 (31.8)
04	.375 (9.5)	.500 (12.7)	1.156 (29.4)	1.250 (31.8)
05	.500 (12.7)	.625 (15.9)	1.250 (31.8)	1.312 (33.3)
06	.625 (15.9)	.750 (19.1)	1.375 (34.9)	1.375 (34.9)
07	.750 (19.1)	.875 (22.2)	1.500 (38.1)	1.500 (38.1)
08	.875 (22.2)	1.000 (25.4)	1.625 (41.3)	1.625 (41.3)
09	1.000 (25.4)	1.125 (28.6)	1.750 (44.5)	1.625 (41.3)
10	1.125 (28.6)	1.250 (31.8)	1.875 (47.6)	1.625 (41.3)

Length Code	Available Shell Sizes		Length	
	Std.			
Std.	08 - 24		1.50	(38.1)
A	08 - 24		2.50	(63.5)
B	14 - 24		3.50	(88.9)
C	20 - 24		4.50	(114.3)

- For complete dimensions see applicable Military Specification.
- Metric dimensions (mm) are indicated in parentheses.
- Cable range is defined as the accommodation range for the wire bundle or cable. Dimensions shown are not intended for inspection criteria.

AS85049/18 EMI/RFI Environmental Backshell



EMI/RFI
Environmental
Backshells

Glenair Connector
Designator H

MIL-DTL-38999
Series III & IV,
EN3645

M85049/18 11 N 03 A

Basic Part No. _____
Shell Size _____
Finish _____

Length Code (Table IV,
Omit for Standard)
Clamp Size (Table II & III)

N = Electroless Nickel
W = 1,000 Hr. Cadmium Olive Drab
Over Electroless Nickel

Shell Size	A Thread Class 2B	B Dia Max
9	M12 X 1 - 6H	.75 (19.1)
11	M15 X 1 - 6H	.85 (21.6)
13	M18 X 1 - 6H	1.00 (25.4)
15	M22 X 1 - 6H	1.15 (29.2)
17	M25 X 1 - 6H	1.25 (31.8)
19	M28 X 1 - 6H	1.40 (35.6)
21	M31 X 1 - 6H	1.55 (39.4)
23	M34 X 1 - 6H	1.65 (41.9)
25	M37 X 1 - 6H	1.85 (47.0)

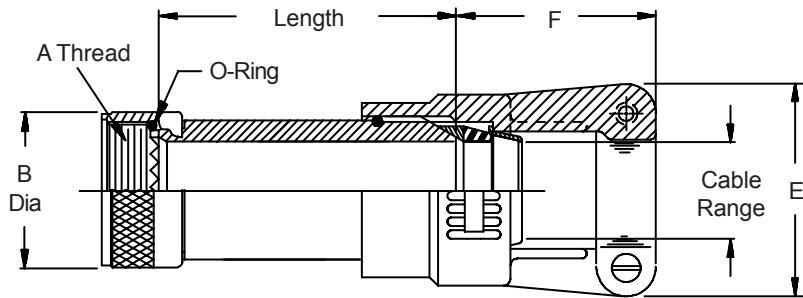

Shell Size	Clamp Size (Table III)	
	Min	Max
9	01	02
11	01	03
13	02	04
15	02	05
17	02	06
19	03	07
21	03	08
23	03	09
25	04	10

Clamp Size	Cable Range		E Max	F Max
	Min	Max		
01	.062 (1.6)	.125 (3.2)	.781 (19.8)	1.250 (31.8)
02	.125 (3.2)	.250 (6.4)	.969 (24.6)	1.250 (31.8)
03	.250 (6.4)	.375 (9.5)	1.062 (27.0)	1.250 (31.8)
04	.375 (9.5)	.500 (12.7)	1.156 (29.4)	1.250 (31.8)
05	.500 (12.7)	.625 (15.9)	1.250 (31.8)	1.312 (33.3)
06	.625 (15.9)	.750 (19.1)	1.375 (34.9)	1.375 (34.9)
07	.750 (19.1)	.875 (22.2)	1.500 (38.1)	1.500 (38.1)
08	.875 (22.2)	1.000 (25.4)	1.625 (41.3)	1.625 (41.3)
09	1.000 (25.4)	1.125 (28.6)	1.750 (44.5)	1.625 (41.3)
10	1.125 (28.6)	1.250 (31.8)	1.875 (47.6)	1.625 (41.3)

Length Code	Available Shell Sizes		Length
	9 - 25	15 - 25	
Std.	9 - 25	15 - 25	1.500 (38.1)
A	9 - 25	15 - 25	2.500 (63.5)
B	15 - 25	15 - 25	3.500 (88.9)
C	21 - 25	15 - 25	4.500 (114.3)

- For complete dimensions see applicable Military Specification.
- Metric dimensions (mm) are indicated in parentheses.
- Cable range is defined as the accommodation range for the wire bundle or cable. Dimensions shown are not intended for inspection criteria.



AS85049/76 EMI/RFI Environmental Backshell

**Glenair Connector
Designator F**

**MIL-DTL-38999 Series I & II,
40M38277, PAN 6433-1,
PATT 614, PATT 616,
NFC93422 Series HE308 &
HE309**

M85049/76-10 W 01

Basic Part No. _____
Shell Size _____
Clamp Size _____
Finish _____

N = Electroless Nickel
W = 1,000 Hr. Cadmium Olive
Drab Over Electroless Nickel

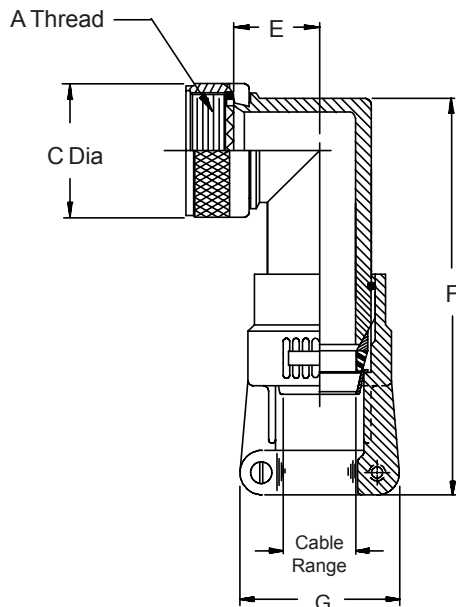

TABLE I

Shell Size	A Thread Class 2B	C Dia Max
08	.438 - 28 UNEF	.75 (19.1)
10	.562 - 24 UNEF	.85 (21.6)
12	.688 - 24 UNEF	1.00 (25.4)
14	.813 - 20 UNEF	1.15 (29.2)
16	.938 - 20 UNEF	1.25 (31.8)
18	1.063 - 18 UNEF	1.40 (35.6)
20	1.188 - 18 UNEF	1.55 (39.4)
22	1.313 - 18 UNEF	1.65 (41.9)
24	1.438 - 18 UNEF	1.85 (47.0)

TABLE II

Shell Size		Clamp Size		E	F
Shell Size	Series 1 Ref.	Min	Max	±.156 (4.0)	±.188 (4.8)
08	09	01	02	.532 (13.5)	3.267 (83.0)
10	11	01	03	.627 (15.9)	3.387 (86.0)
12	13	02	04	.642 (16.3)	3.407 (86.5)
14	15	02	05	.719 (18.3)	3.477 (88.3)
16	17	02	06	.774 (19.7)	3.567 (90.6)
18	19	03	07	.854 (21.7)	3.737 (94.9)
20	21	03	08	.899 (22.8)	3.737 (94.9)
22	23	03	09	1.009 (25.6)	3.847 (97.7)
24	25	04	10	1.024 (26.0)	3.847 (97.7)

TABLE III

Clamp Size	Cable Range		G Max
	Min	Max	
01	.062 (1.6)	.125 (3.2)	.80 (20.3)
02	.125 (3.2)	.250 (6.4)	1.00 (25.4)
03	.250 (6.4)	.375 (9.5)	1.10 (27.9)
04	.375 (9.5)	.500 (12.7)	1.20 (30.5)
05	.500 (12.7)	.625 (15.9)	1.25 (31.8)
06	.625 (15.9)	.750 (19.1)	1.40 (35.6)
07	.750 (19.1)	.875 (22.2)	1.50 (38.1)
08	.875 (22.2)	1.000 (25.4)	1.65 (41.9)
09	1.000 (25.4)	1.125 (28.6)	1.75 (44.5)
10	1.125 (28.6)	1.250 (31.8)	1.90 (48.3)

1. For complete dimensions see applicable Military Specification.
2. Metric dimensions (mm) are indicated in parentheses.
3. Cable range is defined as the accommodation range for the wire bundle or cable.
Dimensions shown are not intended for inspection criteria.

AS85049/77 EMI/RFI Environmental Backshell



EMI/RFI
Environmental
Backshells

Glenair Connector
Designator F

MIL-DTL38999 Series I & II,
40M38277, PAN 6433-1,
PATT 614, PATT 616,
NFC93422 Series HE308 &
HE309

M85049/77-10 W 01

Basic Part No. _____ Clamp Size _____
Shell Size _____ Finish _____
N = Electroless Nickel
W = 1,000 Hr. Cadmium Olive
Drab Over Electroless Nickel

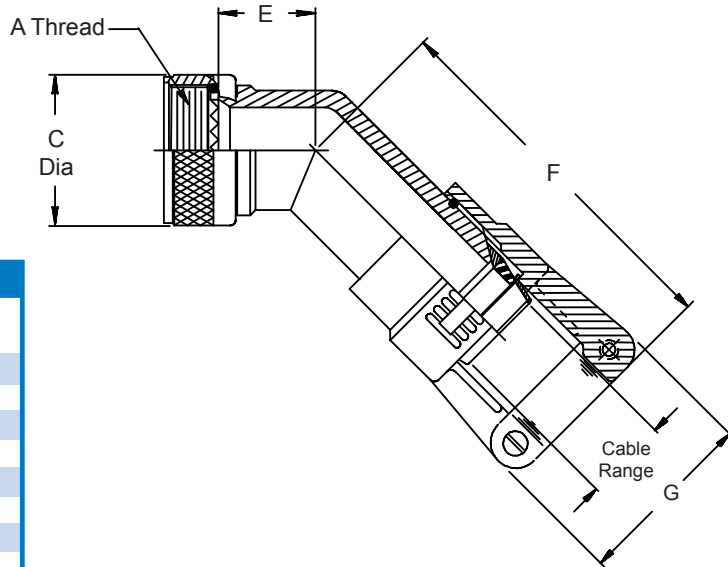

TABLE I

Shell Size	A Thread Class 2B	C Dia Max
08	.438 - 28 UNEF	.75 (19.1)
10	.562 - 24 UNEF	.85 (21.6)
12	.688 - 24 UNEF	1.00 (25.4)
14	.813 - 20 UNEF	1.15 (29.2)
16	.938 - 20 UNEF	1.25 (31.8)
18	1.063 - 18 UNEF	1.40 (35.6)
20	1.188 - 18 UNEF	1.55 (39.4)
22	1.313 - 18 UNEF	1.65 (41.9)
24	1.438 - 18 UNEF	1.85 (47.0)

TABLE II

Shell Size	Shell Size Series 1		Clamp Size	E		F	
	Ref.	Min		Max	±.062 (1.6)	±.062 (1.6)	
08	09	01	02	.398 (10.1)	3.088 (78.4)		
10	11	01	03	.458 (11.6)	3.148 (80.0)		
12	13	02	04	.518 (13.2)	3.208 (81.5)		
14	15	02	05	.588 (14.9)	3.298 (83.8)		
16	17	02	06	.678 (17.2)	3.408 (86.6)		
18	19	03	07	.868 (22.0)	3.598 (91.4)		
20	21	03	08	.868 (22.0)	3.598 (91.4)		
22	23	03	09	.958 (24.3)	3.748 (95.2)		
24	25	04	10	.958 (24.3)	3.748 (95.2)		

TABLE III

Clamp Size	Cable Range		G Max
	Min	Max	
01	.062 (1.6)	.125 (3.2)	.80 (20.3)
02	.125 (3.2)	.250 (6.4)	1.00 (25.4)
03	.250 (6.4)	.375 (9.5)	1.10 (27.9)
04	.375 (9.5)	.500 (12.7)	1.20 (30.5)
05	.500 (12.7)	.625 (15.9)	1.25 (31.8)
06	.625 (15.9)	.750 (19.1)	1.40 (35.6)
07	.750 (19.1)	.875 (22.2)	1.50 (38.1)
08	.875 (22.2)	1.000 (25.4)	1.65 (41.9)
09	1.000 (25.4)	1.125 (28.6)	1.75 (44.5)
10	1.125 (28.6)	1.250 (31.8)	1.90 (48.3)

1. For complete dimensions see applicable Military Specification.
2. Metric dimensions (mm) are indicated in parentheses.
3. Cable range is defined as the accommodation range for the wire bundle or cable. Dimensions shown are not intended for inspection criteria.



AS85049/78 EMI/RFI Environmental Backshell

**Glenair Connector
Designator H**

**MIL-DTL-38999
Series III & IV,
EN3645**

M85049/78-11 W 01

Basic Part No. _____ Clamp Size _____

Shell Size _____ Finish _____

N = Electroless Nickel
W = 1,000 Hr. Cadmium Olive
Drab Over Electroless Nickel

Shell Size	A Thread Class 2B	B Dia Max
9	M12 X 1 - 6H	.75 (19.1)
11	M15 X 1 - 6H	.85 (21.6)
13	M18 X 1 - 6H	1.00 (25.4)
15	M22 X 1 - 6H	1.15 (29.2)
17	M25 X 1 - 6H	1.25 (31.8)
19	M28 X 1 - 6H	1.40 (35.6)
21	M31 X 1 - 6H	1.55 (39.4)
23	M34 X 1 - 6H	1.65 (41.9)
25	M37 X 1 - 6H	1.85 (47.0)

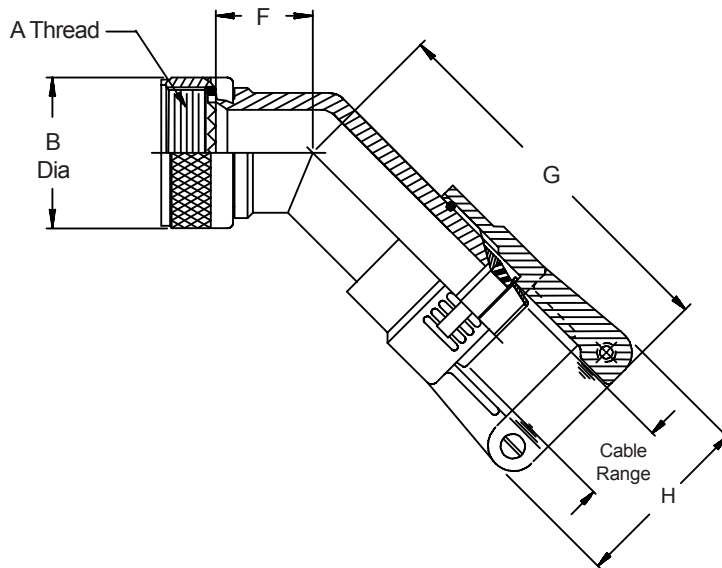

Shell Size	Clamp Size		F	G
	Min	Max	± 0.062 (1.6)	± 0.062 (1.6)
09	01	02	.398 (10.1)	3.088 (78.4)
11	01	03	.458 (11.6)	3.148 (80.0)
13	02	04	.518 (13.2)	3.208 (81.5)
15	02	05	.588 (14.9)	3.298 (83.8)
17	02	06	.678 (17.2)	3.408 (86.6)
19	03	07	.868 (22.0)	3.598 (91.4)
21	03	08	.868 (22.0)	3.598 (91.4)
23	03	09	.958 (24.3)	3.748 (95.2)
25	04	10	.958 (24.3)	3.748 (95.2)

Clamp Size	Cable Range		H
	Min	Max	Max
01	.062 (1.6)	.125 (3.2)	.80 (20.3)
02	.125 (3.2)	.250 (6.4)	1.00 (25.4)
03	.250 (6.4)	.375 (9.5)	1.10 (27.9)
04	.375 (9.5)	.500 (12.7)	1.20 (30.5)
05	.500 (12.7)	.625 (15.9)	1.25 (31.8)
06	.625 (15.9)	.750 (19.1)	1.40 (35.6)
07	.750 (19.1)	.875 (22.2)	1.50 (38.1)
08	.875 (22.2)	1.000 (25.4)	1.65 (41.9)
09	1.000 (25.4)	1.125 (28.6)	1.75 (44.5)
10	1.125 (28.6)	1.250 (31.8)	1.90 (48.3)

1. For complete dimensions see applicable Military Specification.
2. Metric dimensions (mm) are indicated in parentheses.
3. Cable range is defined as the accommodation range for the wire bundle or cable. Dimensions shown are not intended for inspection criteria.

AS85049/79
EMI/RFI Environmental Backshell



EMI/RFI
Environmental
Backshells

Glenair Connector
Designator H

MIL-DTL-38999
Series III & IV,
EN3645

M85049/79-11 W 01

Basic Part No. _____
Shell Size _____
Clamp Size _____
Finish _____

N = Electroless Nickel
W = 1,000 Hour Cadmium Olive
Drab Over Electroless Nickel

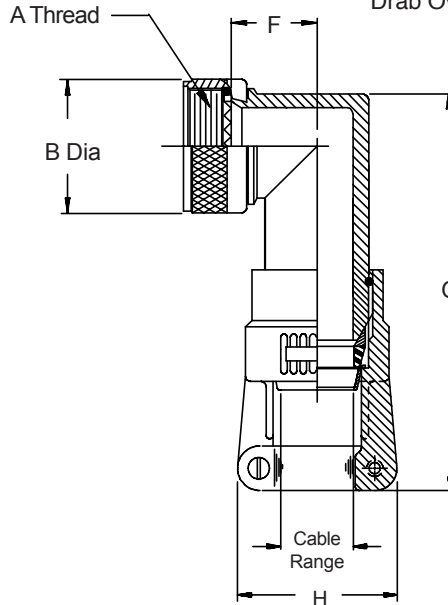

TABLE I

Shell Size	A Thread Class 2B	B Dia Max
9	M12 X 1 - 6H	.75 (19.1)
11	M15 X 1 - 6H	.85 (21.6)
13	M18 X 1 - 6H	1.00 (25.4)
15	M22 X 1 - 6H	1.15 (29.2)
17	M25 X 1 - 6H	1.25 (31.8)
19	M28 X 1 - 6H	1.40 (35.6)
21	M31 X 1 - 6H	1.55 (39.4)
23	M34 X 1 - 6H	1.65 (41.9)
25	M37 X 1 - 6H	1.85 (47.0)

TABLE II

Shell Size	Clamp Size		F		G	
	Min	Max	± 0.062	(1.6)	± 0.062	(1.6)
09	01	02	.438	(11.1)	3.141	(79.8)
11	01	03	.533	(13.5)	3.261	(82.8)
13	02	04	.548	(13.9)	3.281	(83.3)
15	02	05	.638	(16.2)	3.351	(85.1)
17	02	06	.823	(20.9)	3.441	(87.4)
19	03	07	.913	(23.2)	3.611	(91.7)
21	03	08	.913	(23.2)	3.611	(91.7)
23	03	09	1.063	(27.0)	3.721	(94.5)
25	04	10	1.063	(27.0)	3.721	(94.5)

TABLE III

Clamp Size	Cable Range		H Max
	Min	Max	
01	.062 (1.6)	.125 (3.2)	.80 (20.3)
02	.125 (3.2)	.250 (6.4)	1.00 (25.4)
03	.250 (6.4)	.375 (9.5)	1.10 (27.9)
04	.375 (9.5)	.500 (12.7)	1.20 (30.5)
05	.500 (12.7)	.625 (15.9)	1.25 (31.8)
06	.625 (15.9)	.750 (19.1)	1.40 (35.6)
07	.750 (19.1)	.875 (22.2)	1.50 (38.1)
08	.875 (22.2)	1.000 (25.4)	1.65 (41.9)
09	1.000 (25.4)	1.125 (28.6)	1.75 (44.5)
10	1.125 (28.6)	1.250 (31.8)	1.90 (48.3)

1. For complete dimensions see applicable Military Specification.
2. Metric dimensions (mm) are indicated in parentheses.
3. Cable range is defined as the accommodation range for the wire bundle or cable. Dimensions shown are not intended for inspection criteria.

Tired of waiting an eternity for
a simple connector or accessory?

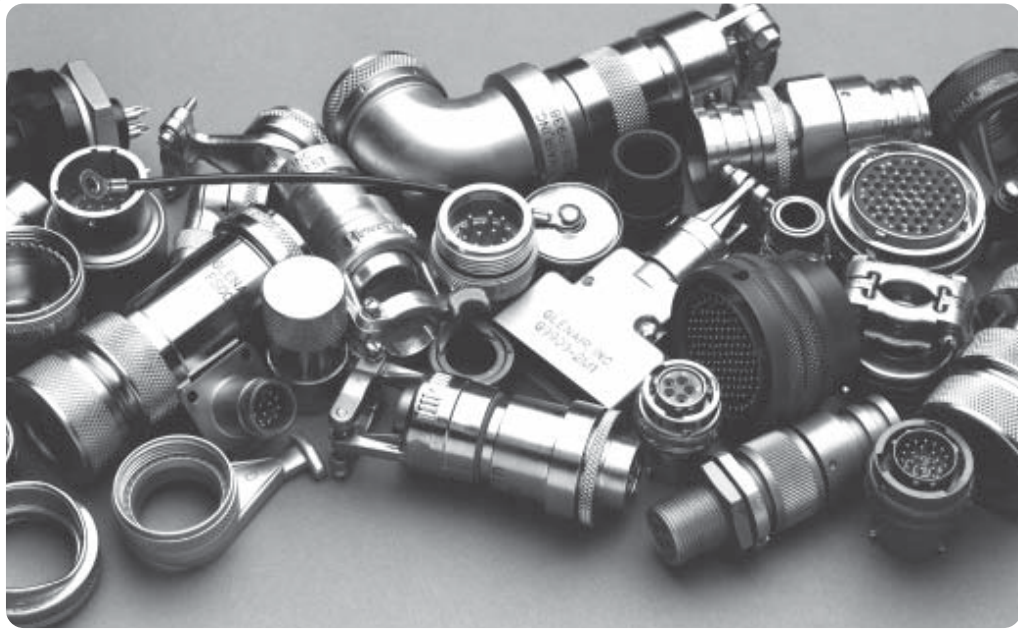

Then Glenair's "Same Day Delivery"
program is the answer.

Tired of long lead times for connectors and accessories? Then consider over 35,000 different part numbers in stock, in quantity, and ready for immediate same-day shipment—including virtually every Mil Spec accessory in the book. Consider as

well Glenair's "no minimum order" policy and our lightning fast turnaround on quotes for price and delivery.

Visit our website at www.glenair.com to search our Same-Day Inventory for all your time-sensitive interconnect requirements.



Commercial and Mil Spec
connector accessories



Convoluting tubing and
metal-core conduit



Electrical and fiber optic
cable assemblies



Composite thermoplastic
components



Microminiature connectors
and accessories



Backshell assembly and
termination tools



1211 Air Way

Glendale, California 91201-2497

Telephone: 818-247-6000 · Facsimile: 818-500-9912 · EMail: sales@glenair.com

United States · United Kingdom · Germany · Nordic · France · Italy · Spain

www.glenair.com

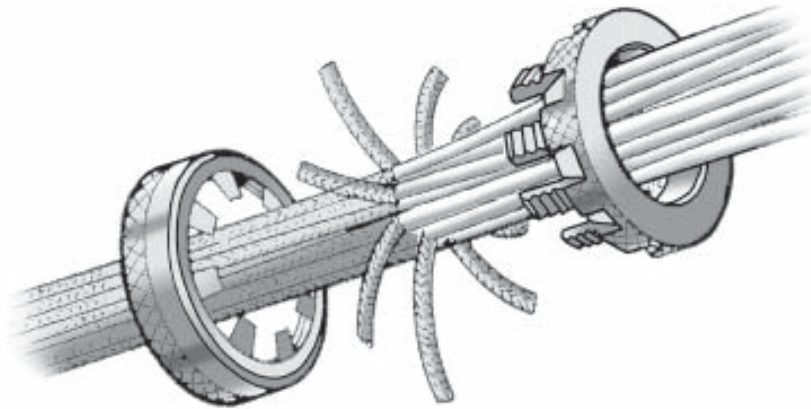

Glenair's TAG® Ring backshells offer a unique and reliable method of terminating individually shielded wires where the shields are to be grounded through the backshell and connector shell. No special tools are required for assembly and full maintainability is provided.

Military Specification	Superceding Part Number	Glenair's Commercial Catalog P/N	Description	Glenair Connector Designator	Page Number
MS27741		410-003	TAG® Ring	-	40-2
M38999/4	M85049/30	400-001	TAG® Ring Adapter	F	40-3*
AS85049/30		400-001	TAG® Ring Adapter	F	40-3

* Page Number of Superceding Part Number
** Consult Factory

MS27741-10

Basic Part No. _____

Shell Size _____

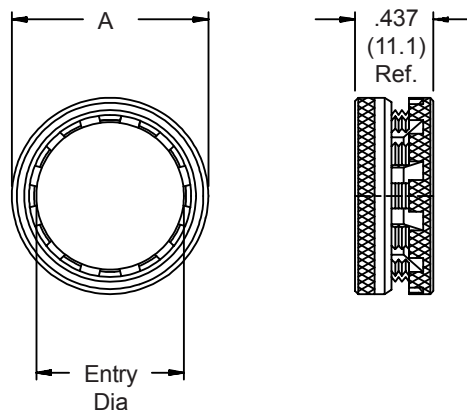

TABLE I

Dash No.	A Dia Max	Entry Dia.	No. of Slots	Weight in Grams
2	.545 (13.8)	.250 (6.4)	3	2.268
3	.670 (17.0)	.375 (9.5)	4	2.722
4	.795 (20.2)	.500 (12.7)	6	3.175
5	.920 (23.4)	.625 (15.9)	8	4.082
6	1.045 (26.5)	.750 (19.1)	10	4.536
7	1.170 (29.7)	.875 (22.2)	10	4.990
8	1.295 (32.9)	1.000 (25.4)	12	5.443
9	1.420 (36.1)	1.125 (28.6)	15	6.350
10	1.687 (42.8)	1.250 (31.8)	15	10.433
11	1.812 (46.0)	1.375 (34.9)	15	14.515

1. For complete dimensions see applicable Military Specification.
2. Finish: Body and Nut - Gold Iridite; Spring - Gold Plate.
3. Metric dimensions (mm) are indicated in parentheses.

AS85049/30
TAG® Ring Backshells



TAG® Ring Backshells

Glenair Connector
Designator F

MIL-DTL-38999 Series I &
II, 40M38277, PAN 6433-1,
PATT 614, PATT 616,
NFC93422 Series HE308 &
HE309

M85049/30-10 W

Basic Part No. ————
Shell Size ————

Finish
N = Electroless Nickel
W = 1,000 Hour Cadmium Olive Drab
Over Electroless Nickel

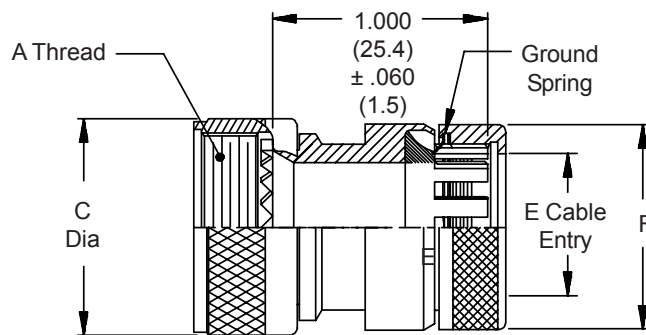
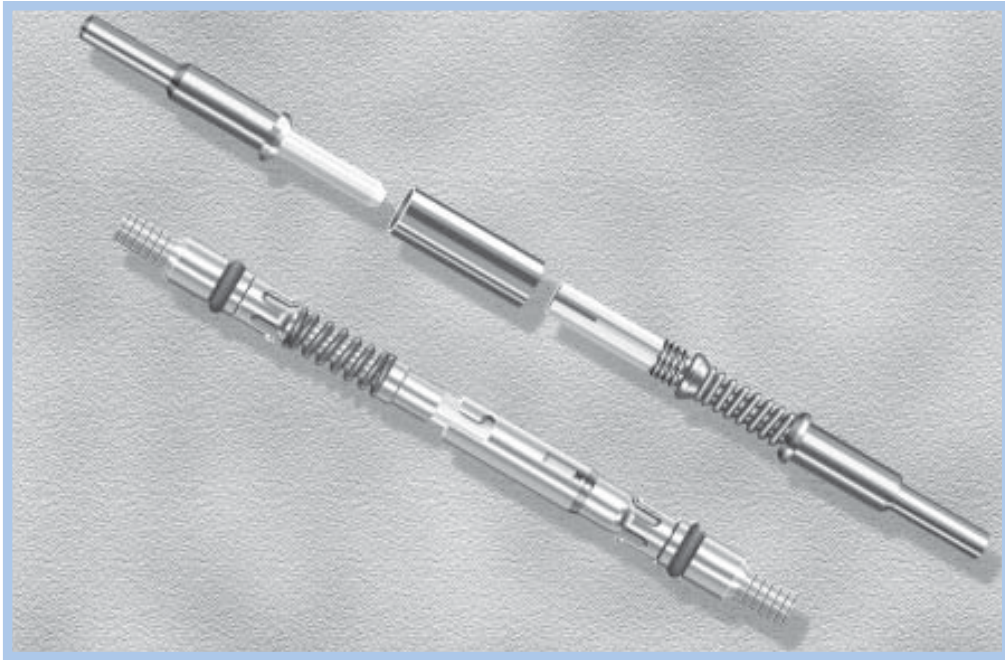

TABLE I

Shell Size	Shell Size		C Dia Max	E Cable Entry Max	F Dia Max
	Series I Ref.	A Thread Class 2B			
08	9	.438 - 28 UNEF	.75 (19.1)	.250 (6.4)	.545 (13.8)
10	11	.562 - 24 UNEF	.85 (21.6)	.375 (9.5)	.670 (17.0)
12	13	.688 - 24 UNEF	1.00 (25.4)	.500 (12.7)	.795 (20.2)
14	15	.813 - 20 UNEF	1.10 (27.9)	.625 (15.9)	.920 (23.4)
16	17	.938 - 20 UNEF	1.25 (31.8)	.750 (19.1)	1.045 (26.5)
18	19	1.063 - 18 UNEF	1.40 (35.6)	.844 (21.4)	1.170 (29.7)
20	21	1.188 - 18 UNEF	1.50 (38.1)	.970 (24.6)	1.295 (32.9)
22	23	1.313 - 18 UNEF	1.65 (41.9)	1.094 (27.8)	1.420 (36.1)
24	25	1.438 - 18 UNEF	1.75 (44.5)	1.219 (31.0)	1.670 (42.4)

1. For complete dimensions see applicable Military Specification.
2. Metric dimensions (mm) are indicated in parentheses.

Good Things Come In Small Packages



And at Glenair, They Ship the Same Day

Tired of long lead times for F/O connectors and contacts? Then consider the Glenair difference: We've placed our products in stock, in quantity, and ready for immediate shipment—including both our MIL-T-29504 qualified pin and socket termini as well as our new front-

release 181-011 and 181-012 designs. Consider as well Glenair's "no minimum order" policy and our lightning fast turnaround on quotes for price and delivery. At Glenair, we're committed to keeping our products, programs and services current with your every need.



1211 Air Way
Glendale, California 91201-2497
Telephone: 818-247-6000 · Facsimilie: 818-500-9912 · EMail: sales@glenair.com

United States · United Kingdom · Germany · Nordic · France · Italy · Spain

www.glenair.com



Crimp Ring Backshells

Crimp ring backshells provide an economical approach to terminating overall cable and harness shields where future repairability or maintainability are not required. These backshells use standard outer crimp rings for full 360° shield termination, and are available in versions for use with shrink boots or for molded cable terminations.

Banding Backshells

Banding backshells provide an economical approach to terminating overall cable and harness shields/screens. These backshells utilize standard bands for full 360° shield/screen termination with the lowest dc resistance available.

Military Specification	Superceding Part Number	Glenair's Commercial Catalog P/N	Description	Connector Designator	Page Number
MS3419	M85049/26-1	440AS063	Crimp Ring Adapter	A	44-3
M38999/3	M85049/33-2	440FS063	Crimp Ring Adapter	F	44-4*
AS85049/20		440FS063	Crimp Ring Adapter	H	44-2
AS85049/26-1		440AS063	Crimp Ring Adapter	A	44-3
AS85049/26-2		**	Crimp Ring	-	44-3
AS85049/26-3		440AS063	Crimp Ring Adapter With Crimp Ring	A	44-3
AS85049/33-2		440FS063	Crimp Ring Adapter	F	44-4
AS85049/82		440AS069	Str. Banding Backshell	A	44-5
AS85049/83		440AH069	45° Banding Backshell	A	44-5
AS85049/84		440AJ069	90° Banding Backshell	A	44-5
AS85049/85		440FS069	Str. Banding Backshell	F	44-6
AS85049/86		440FH069	45° Banding Backshell	F	44-6
AS85049/87		440FJ069	90° Banding Backshell	F	44-6
AS85049/88		440HS069	Str. Banding Backshell	H	44-8
AS85049/89		440HH069	45° Banding Backshell	H	44-8
AS85049/90		440HJ069	90° Banding Backshell	H	44-8

* Page Number of Superceding Part Number
** Consult Factory

AS85049/20 Crimp Ring Backshell

Glenair Connector
Designator H

MIL-DTL-38999
Series III & IV,
EN3645

M85049/20-11 W

Basic Part No.

Shell Size

Finish

N = Electroless Nickel

W = 1,000 Hour Cadmium Olive

Drab Over Electroless Nickel

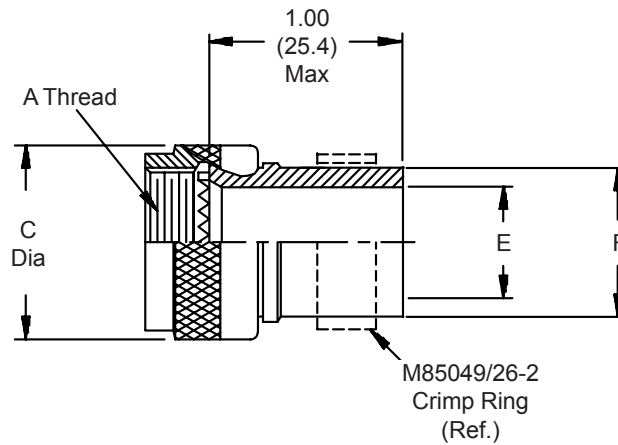

TABLE I

Shell Size	A Thread Class 2B	C Dia Max	E Max Cable Entry	F Dia	M85049/26-2 Crimp Ring Ref.
9	M12 X 1 - 6H	.75 (19.1)	.265 (6.7)	.347 (8.8)	8
11	M15 X 1 - 6H	.85 (21.6)	.343 (8.7)	.498 (12.6)	10
13	M18 X 1 - 6H	1.00 (25.4)	.437 (11.1)	.510 (13.0)	12
15	M22 X 1 - 6H	1.10 (27.9)	.562 (14.3)	.630 (16.0)	14
17	M25 X 1 - 6H	1.25 (31.8)	.687 (17.4)	.760 (19.3)	16
19	M28 X 1 - 6H	1.40 (35.6)	.812 (20.6)	.890 (22.6)	18
21	M31 X 1 - 6H	1.50 (38.1)	.937 (23.8)	1.010 (25.7)	20
23	M34 X 1 - 6H	1.65 (41.9)	1.046 (26.6)	1.130 (28.7)	22
25	M37 X 1 - 6H	1.75 (44.5)	1.125 (28.6)	1.202 (30.5)	24

1. For complete dimensions see applicable Military Specification.
2. Metric dimensions (mm) are indicated in parentheses.

MS3419 and AS85049/26 Crimp Ring Backshell



Crimp Ring
and Banding
Backshells

**Glenair Connector
Designator A**

MIL-DTL-5015 Series 3400,
MIL-DTL-26482 Series 2,
AS81703 Series 3,
MIL-DTL-83723 Series I & III

M85049/26-1-12 W

Basic Part No. _____
M85049/26-1 = Adapter Only
M85049/26-2 = Crimp Ring Only
M85049/26-3 = Adapter with Crimp Ring

Shell Size _____

Finish (Not Applicable
for M85049/26-2)
N = Electroless Nickel
W = 1,000 Hour Cadmium
Olive Drab Over
Electroless Nickel

TABLE I

Shell Size	A Thread Class 2B	C Dia Max
3	.562 - 24 UNEF	.67 (17.0)
8	.500 - 20 UNF	.62 (15.7)
10	.625 - 24 UNEF	.73 (18.5)
12	.750 - 20 UNEF	.86 (21.8)
14	.875 - 20 UNEF	.98 (24.9)
16	1.000 - 20 UNEF	1.11 (28.2)
18	1.062 - 18 UNEF	1.22 (31.0)
20	1.188 - 18 UNEF	1.35 (34.3)
22	1.313 - 18 UNEF	1.47 (37.3)
24	1.438 - 18 UNEF	1.59 (40.4)
28	1.750 - 18 UNS	1.97 (50.0)
32	2.000 - 18 UNS	2.22 (56.4)
36	2.250 - 16 UN	2.47 (62.7)
40	2.500 - 16 UN	2.72 (69.1)
44	2.750 - 16 UN	2.97 (75.4)
48	3.000 - 16 UN	3.22 (81.8)
61	1.500 - 18 UNEF	1.65 (41.9)

MS3419-21 C

Basic Part No. _____
Adapter Only

Dash No. _____

Finish
A = Electroless Nickel
C = 500 Hour Cadmium Olive Drab
Over Electroless Nickel

Superseded Part Number

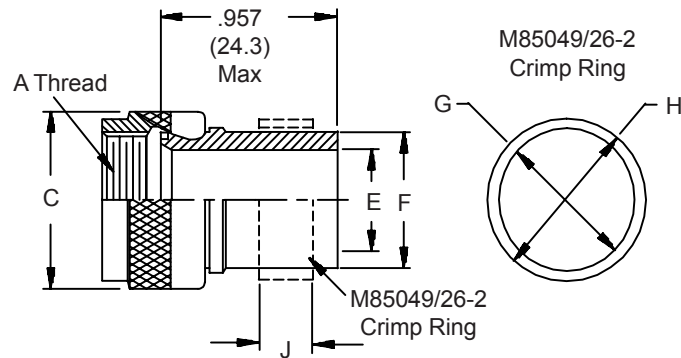

TABLE II

M85049/26-3 (Adapter with Crimp Ring) Shell Size	M85049/26-1 (Adapter Only) MS3419 (Adapter Only)				M85049/26-2 (Crimp Ring Only)			
	Shell Size	E Dia	F Dia		Shell Size	G Min	H Min	J
3	3	.250 (6.4)	.337 (8.6)					
8	8	.250 (6.4)	.337 (8.6)	8	.400 (10.2)	.448 (11.4)	.250 (6.4)	
10	10	.325 (8.3)	.488 (12.4)	10	.585 (14.9)	.660 (16.8)	.440 (11.2)	
12	12	.420 (10.7)	.500 (12.7)	12	.585 (14.9)	.660 (16.8)	.440 (11.2)	
14	14	.540 (13.7)	.620 (15.7)	14	.705 (17.9)	.780 (19.8)	.440 (11.2)	
16	16	.670 (17.0)	.750 (19.1)	16	.835 (21.2)	.910 (23.1)	.440 (11.2)	
18	18	.789 (20.0)	.880 (22.4)	18	1.005 (25.5)	1.080 (27.4)	.440 (11.2)	
20	20	.914 (23.2)	1.000 (25.4)	20	1.125 (28.6)	1.200 (30.5)	.440 (11.2)	
22	22	1.039 (26.4)	1.120 (28.4)	22	1.245 (31.6)	1.320 (33.5)	.440 (11.2)	
24	24	1.112 (28.2)	1.192 (30.3)	24	1.327 (33.7)	1.402 (35.6)	.440 (11.2)	
28	28	1.389 (35.3)	1.545 (39.2)	28	1.665 (42.3)	1.740 (44.2)	.440 (11.2)	
32	32	1.635 (41.5)	1.795 (45.6)	32	1.915 (48.6)	1.990 (50.5)	.440 (11.2)	
36	36	1.850 (47.0)	2.045 (51.9)	36	2.165 (55.0)	2.240 (56.9)	.440 (11.2)	
40	40	2.065 (52.5)	2.295 (58.3)	40	2.415 (61.3)	2.490 (63.2)	.440 (11.2)	
44	44	2.320 (58.9)	2.545 (64.6)	44	2.665 (67.7)	2.740 (69.6)	.440 (11.2)	
48	48	2.570 (65.3)	2.795 (71.0)	48	2.915 (74.0)	2.990 (75.9)	.440 (11.2)	
61	61	1.210 (30.7)	1.359 (34.5)	61	1.435 (36.4)	1.510 (38.4)	.440 (11.2)	

1. For complete dimensions see applicable Military Specification.
2. Metric dimensions (mm) are indicated in parentheses.

AS85049/33-2 Crimp Ring Backshell

**Glenair Connector
Designator F**

**MIL-DTL-38999 Series I & II,
40M38277, PAN 6433-1, PATT
614, PATT 616,
NFC93422 Series HE308 &
HE309**

M85049/33-2-10 W

Basic Part No.

Shell Size

Finish

N = Electroless Nickel

W = 1,000 hour Cadmium Olive Drab
Over Electroless Nickel

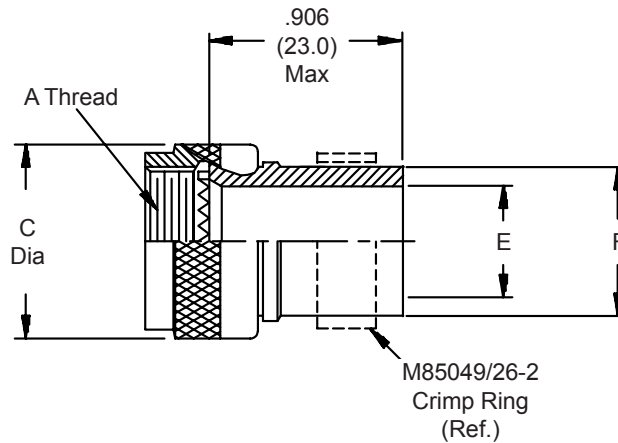

TABLE I

Shell Size	A Thread Class 2B	C Dia Max	E Dia	F Dia Max	M85049/26-2 Crimp Ring Ref.
08	.438 - 28 UNEF	.75 (19.1)	.250 (6.4)	.347 (8.8)	8
10	.562 - 24 UNEF	.85 (21.6)	.325 (8.3)	.498 (12.6)	10
12	.688 - 24 UNEF	1.00 (25.4)	.420 (10.7)	.510 (13.0)	12
14	.813 - 20 UNEF	1.10 (27.9)	.540 (13.7)	.630 (16.0)	14
16	.938 - 20 UNEF	1.25 (31.8)	.670 (17.0)	.760 (19.3)	16
18	1.063 - 18 UNEF	1.40 (35.6)	.789 (20.0)	.890 (22.6)	18
20	1.188 - 18 UNEF	1.50 (38.1)	.914 (23.2)	1.010 (25.7)	20
22	1.313 - 18 UNEF	1.65 (41.9)	1.039 (26.4)	1.130 (28.7)	22
24	1.438 - 18 UNEF	1.75 (44.5)	1.112 (28.2)	1.202 (30.5)	24

1. For complete dimensions see applicable Military Specification.
2. Metric dimensions (mm) are indicated in parentheses.

AS85049/82, AS85049/83, and AS85049/84 Banding Backshells



Crimp Ring
and Banding
Backshells

Glenair Connector Designator A

MIL-DTL-5015 Series 3400,
MIL-DTL-26482 Series 2,
AS81703 Series 3,
MIL-DTL-83723 Series I &
III, 40M39569, DEF 5326-3,
EN 2997, EN 3646,
ESC 10, ESC 11, LN 29504,
NFC93422 Series HE302,
PAN 6432-1, PAN 6432-2,
PATT 602

M85049/82-16 P 02

Basic Part No.:
M85049/82 = Straight
M85049/83 = 45°
M85049/84 = 90°

Entry Size

Finish

Shell Size

N = Electroless Nickel
P = Cadmium Olive Drab over
Electroless Nickel with
Polysulfide Sealant Strips
W = 1,000 Hour Cadmium Olive
Drab Over Electroless Nickel

Self Locking Coupling

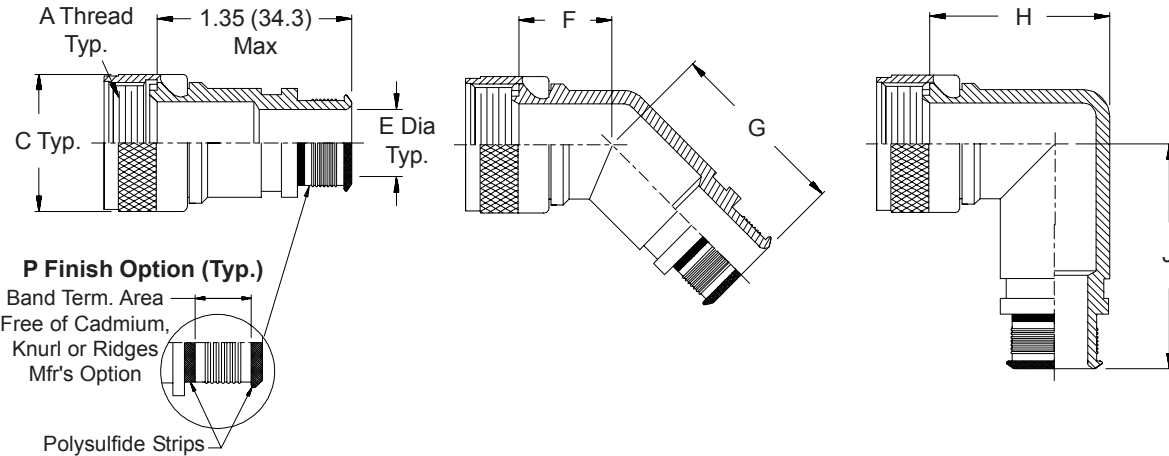

TABLE I

Shell Size	A Thread Class 2B	C Dia Max	E Dia Cable Entry Size 02		E Dia Cable Entry Size 03		F Max	G Max	H Max	J Max
			±.010	(.3)	±.010	(.3)				
08	.500 - 20 UNF	.88 (22.4)	N/A	N/A	.250 (6.4)	.87 (22.1)	1.16 (29.5)	1.188 (30.2)	1.417 (36.0)	
10	.625 - 24 UNEF	1.01 (25.7)	N/A	N/A	.312 (7.9)	.89 (22.6)	1.18 (30.0)	1.281 (32.5)	1.480 (37.6)	
12	.750 - 20 UNEF	1.13 (28.7)	.312 (7.9)	.438 (11.1)	.438 (11.1)	.92 (23.4)	1.20 (30.5)	1.406 (35.7)	1.542 (39.2)	
14	.875 - 20 UNEF	1.26 (32.0)	.438 (11.1)	.562 (14.3)	.562 (14.3)	.94 (23.9)	1.22 (31.0)	1.531 (38.9)	1.605 (40.8)	
16	1.000 - 20 UNEF	1.38 (35.1)	.500 (12.7)	.625 (15.9)	.625 (15.9)	.96 (24.4)	1.25 (31.8)	1.656 (42.1)	1.667 (42.3)	
18	1.062 - 18 UNEF	1.51 (38.4)	.625 (15.9)	.750 (19.1)	.750 (19.1)	.98 (24.9)	1.26 (32.0)	1.718 (43.6)	1.730 (43.9)	
20	1.188 - 18 UNEF	1.63 (41.4)	.625 (15.9)	.812 (20.6)	.812 (20.6)	1.00 (25.4)	1.29 (32.8)	1.844 (46.8)	1.792 (45.5)	
22	1.313 - 18 UNEF	1.76 (44.7)	.688 (17.5)	.938 (23.8)	.938 (23.8)	1.03 (26.2)	1.31 (33.3)	1.938 (49.2)	1.850 (47.0)	
24	1.438 - 18 UNEF	1.88 (47.8)	.750 (19.1)	1.000 (25.4)	1.000 (25.4)	1.05 (26.7)	1.34 (34.0)	2.093 (53.2)	1.917 (48.7)	
28	1.750 - 18 UNS	2.13 (54.1)	.875 (22.2)	1.125 (28.6)	1.125 (28.6)	1.10 (27.9)	1.38 (35.1)	2.531 (64.3)	2.042 (51.9)	

1. For complete dimensions see applicable Military Specification.
2. Metric dimensions (mm) are indicated in parentheses.

Glenair Connector
Designator F

MIL-DTL-38999 Series I & II,
40M38277, PAN 6433-1, PATT
614, PATT 616,
NFC93422 Series HE308 &
HE309

M85049/85-16 P 02

Basic Part No.:

M85049/85 = Straight
M85049/86 = 45°
M85049/87 = 90°

Shell Size

Entry Size

Finish

N = Electroless Nickel
P = Cadmium Olive Drab over
Electroless Nickel with
Polysulfide Sealant Strips
W = 1,000 Hour Cadmium Olive
Drab Over Electroless Nickel

Self Locking Coupling

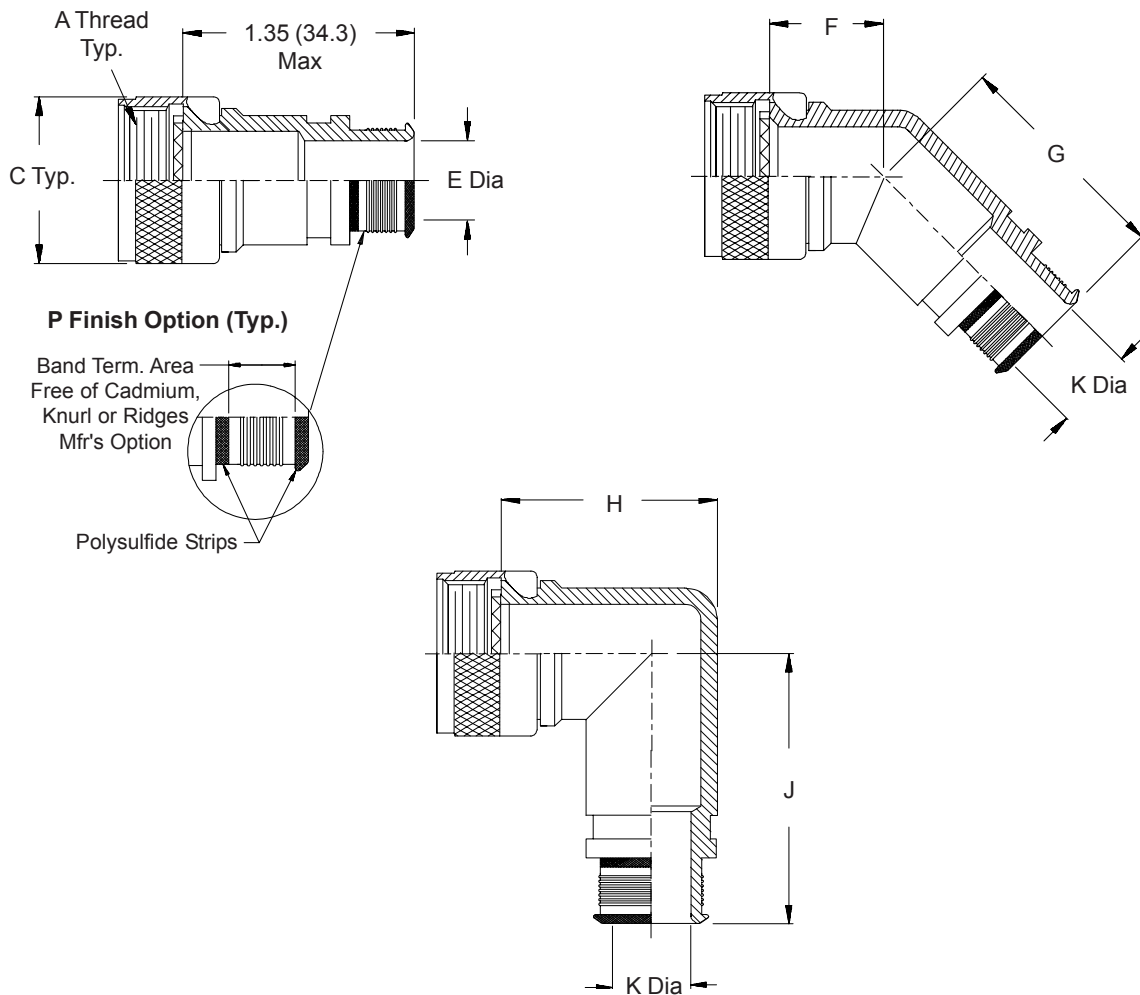

AS85049/85, AS85049/86, and AS85049/87
Banding Backshells



Crimp Ring
and Banding
Backshells

TABLE I

Shell Size	A Thread Class 2B	C Dia Max	F Max	G Max	H Max	J Max
08	.438 - 28 UNEF	.86 (21.8)	.87 (22.1)	1.16 (29.5)	1.375 (34.9)	1.417 (36.0)
10	.562 - 24 UNEF	.99 (25.1)	.90 (22.9)	1.19 (30.2)	1.437 (36.5)	1.480 (37.6)
12	.688 - 24 UNEF	1.16 (29.5)	.92 (23.4)	1.21 (30.7)	1.562 (39.7)	1.553 (39.4)
14	.813 - 20 UNEF	1.28 (32.5)	.95 (24.1)	1.24 (31.5)	1.687 (42.8)	1.614 (41.0)
16	.938 - 20 UNEF	1.41 (35.8)	.98 (24.9)	1.26 (32.0)	1.750 (44.5)	1.678 (42.6)
18	1.063 - 18 UNEF	1.52 (38.6)	.98 (24.9)	1.27 (32.3)	1.875 (47.6)	1.733 (44.0)
20	1.188 - 18 UNEF	1.64 (41.7)	1.01 (25.7)	1.30 (33.0)	1.938 (49.2)	1.796 (45.6)
22	1.313 - 18 UNEF	1.77 (45.0)	1.04 (26.4)	1.33 (33.8)	2.062 (52.4)	1.859 (47.2)
24	1.438 - 18 UNEF	1.89 (48.0)	1.07 (27.2)	1.35 (34.3)	2.125 (54.0)	1.919 (48.7)

TABLE II - Straight Only

Shell Size	E Dia		E Dia	
	Entry Size 01 ±.010 (.3)	Entry Size 02 ±.010 (.3)	Entry Size 01 ±.010 (.3)	Entry Size 02 ±.010 (.3)
08	N/A	.250 (6.4)		
10	N/A	.312 (7.9)		
12	.312 (7.9)	.438 (11.1)		
14	.438 (11.1)	.562 (14.3)		
16	.500 (12.7)	.625 (15.9)		
18	.625 (15.9)	.750 (19.1)		
20	.625 (15.9)	.812 (20.6)		
22	.688 (17.5)	.938 (23.8)		
24	.750 (19.1)	1.000 (25.4)		

TABLE III - 45° and 90° Only

Shell Size	K Dia		K Dia	
	Entry Size 02 ±.010 (.3)	Entry Size 03 ±.010 (.3)	Entry Size 02 ±.010 (.3)	Entry Size 03 ±.010 (.3)
08	N/A	.250 (6.4)		
10	N/A	.312 (7.9)		
12	.312 (7.9)	.438 (11.1)		
14	.438 (11.1)	.562 (14.3)		
16	.500 (12.7)	.625 (15.9)		
18	.625 (15.9)	.750 (19.1)		
20	.625 (15.9)	.812 (20.6)		
22	.688 (17.5)	.938 (23.8)		
24	.750 (19.1)	1.000 (25.4)		

1. For complete dimensions see applicable Military Specification.
2. Metric dimensions (mm) are indicated in parentheses.

AS85049/88, AS85049/89, and AS85049/90 Banding Backshells

Glenair Connector
Designator H

MIL-DTL-38999
Series III & IV,
EN3645

M85049/88-17 P 02

Basic Part No.: _____
 M85049/88 = Straight
 M85049/89 = 45°
 M85049/90 = 90°
 Entry Size _____
 Finish and Material _____
 Shell Size _____

Self Locking Coupling

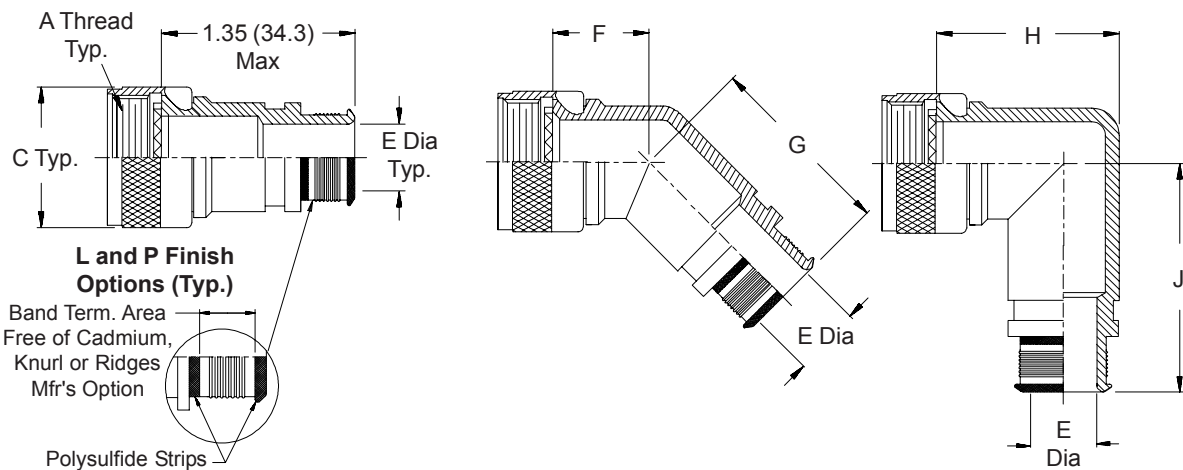

TABLE I

Shell Size	A Thread Class 2B	C Dia Max	E Dia Cable Entry		F Max	G Max	H Max	J Max
			Size 02 ±.010 (.3)	Size 03 ±.010 (.3)				
9	M12 X 1 - 6H	.86 (21.8)	N/A	.250 (6.4)	1.01 (25.7)	1.16 (29.5)	1.375 (34.9)	1.417 (36.0)
11	M15 X 1 - 6H	.99 (25.1)	N/A	.312 (7.9)	1.03 (26.2)	1.19 (30.2)	1.437 (36.5)	1.480 (37.6)
13	M18 X 1 - 6H	1.16 (29.5)	.312 (7.9)	.438 (11.1)	1.06 (26.9)	1.21 (30.7)	1.562 (39.7)	1.553 (39.4)
15	M22 X 1 - 6H	1.28 (32.5)	.438 (11.1)	.562 (14.3)	1.08 (27.4)	1.24 (31.5)	1.687 (42.8)	1.614 (41.0)
17	M25 X 1 - 6H	1.41 (35.8)	.500 (12.7)	.625 (15.9)	1.11 (28.2)	1.26 (32.0)	1.750 (44.5)	1.678 (42.6)
19	M28 X 1 - 6H	1.52 (38.6)	.625 (15.9)	.750 (19.1)	1.12 (28.4)	1.27 (32.3)	1.875 (47.6)	1.733 (44.0)
21	M31 X 1 - 6H	1.64 (41.7)	.625 (15.9)	.812 (20.6)	1.15 (29.2)	1.30 (33.0)	1.938 (49.2)	1.796 (45.6)
23	M34 X 1 - 6H	1.77 (45.0)	.688 (17.5)	.938 (23.8)	1.17 (29.7)	1.33 (33.8)	2.062 (52.4)	1.859 (47.2)
25	M37 X 1 - 6H	1.89 (48.0)	.750 (19.1)	1.000 (25.4)	1.20 (30.5)	1.35 (34.3)	2.125 (54.0)	1.919 (48.7)

- For complete dimensions see applicable Military Specification.
- Metric dimensions (mm) are indicated in parentheses.

TABLE II

Finish Option	Aluminum Material	Composite Material	Finish
G		Not Available	Electroless Nickel (Space Grade)
N		M	Electroless Nickel
P		L	Cadmium Olive Drab Over Electroless Nickel with Polysulfide Sealant Strips
W		J	1,000 Hour Cadmium Olive Drab Over Electroless Nickel

Qwik-Ty® Strain Reliefs



Glenair's Qwik-Ty® strain reliefs offer a unique method of providing strain relief to open wire bundles used with circular connectors. The Qwik-Ty® provides a low profile, reduced weight and simple installation. Installation is quick and secure, using either plastic tie straps or lacing tape.

Military Specification	Superceeding Part Number	Glenair's Commercial Catalog P/N	Description	Glenair Connector Designator	Page Number
MS3152	M85049/53	450AS001	Straight Qwik-Ty® Strain Relief	A	45-4*
MS3153	M85049/54	450AB001	45° Qwik-Ty® Strain Relief	A	45-4*
MS3154	M85049/55	450AA001	90° Qwik-Ty® Strain Relief	A	45-4*
MS27668	M85049/56	450FS001	Straight Qwik-Ty® Strain Relief	F	45-5*
MS27669	M85049/57	450FB001	45° Qwik-Ty® Strain Relief	F	45-5*
MS27670	M85049/63	450FA001	90° Qwik-Ty® Strain Relief	F	45-5*
M83723/50A		**	90° Qwik-Ty® Strain Relief	K	45-2
M83723/50B		**	45° Qwik-Ty® Strain Relief	K	45-2
M83723/50R		**	Straight Qwik-Ty® Strain Relief	K	45-2
AS85049/15G		**	45° Qwik-Ty® Strain Relief, Self Locking with Ground Lug	H	45-3
AS85049/15S		**	45° Qwik-Ty® Strain Relief, Self Locking	H	45-3
AS85049/16G		**	90° Qwik-Ty® Strain Relief, Self Locking with Ground Lug	H	45-3
AS85049/16S		**	90° Qwik-Ty® Strain Relief, Self Locking	H	45-3
AS85049/53	M85049/52	450AS001	Straight Qwik-Ty® Strain Relief	A	45-4
AS85049/54	M85049/43	450AB001	45° Qwik-Ty® Strain Relief	A	45-4
AS85049/55	M85049/51	450AA001	90° Qwik-Ty® Strain Relief	A	45-4
AS85049/55G	M85049/51S	450AA001	90° Qwik-Ty® Strain Relief, Self Locking with Ground Lug	A	45-4
AS85049/55S	M85049/51S	**	90° Qwik-Ty® Strain Relief, Self Locking	A	45-4
AS85049/56		450FS001	Str. Qwik-Ty® Strain Relief	F	45-5
AS85049/57		450FB001	45° Qwik-Ty® Strain Relief	F	45-5
AS85049/57G		450FB001	45° Qwik-Ty® Strain Relief, Self Locking with Ground Lug	F	45-5
AS85049/57S		**	45° Qwik-Ty® Strain Relief, Self Locking	F	45-5
AS85049/63		450FA001	90° Qwik-Ty® Strain Relief	F	45-5
AS85049/63G		450FA001	90° Qwik-Ty® Strain Relief	F	45-5
AS85049/63S		**	90° Qwik-Ty® Strain Relief	F	45-5

* Page Number of Superceeding Part Number
** Consult Factory

**Glenair Connector
Designator K**

**MIL-DTL-83723
Series II**

M83723/50 R 22 N

Basic Part No. ————
Angular Function ————
R = Straight
B = 45°
A = 90°
Finish
A = Black Anodize
N = Electroless Nickel
Dash No. ————

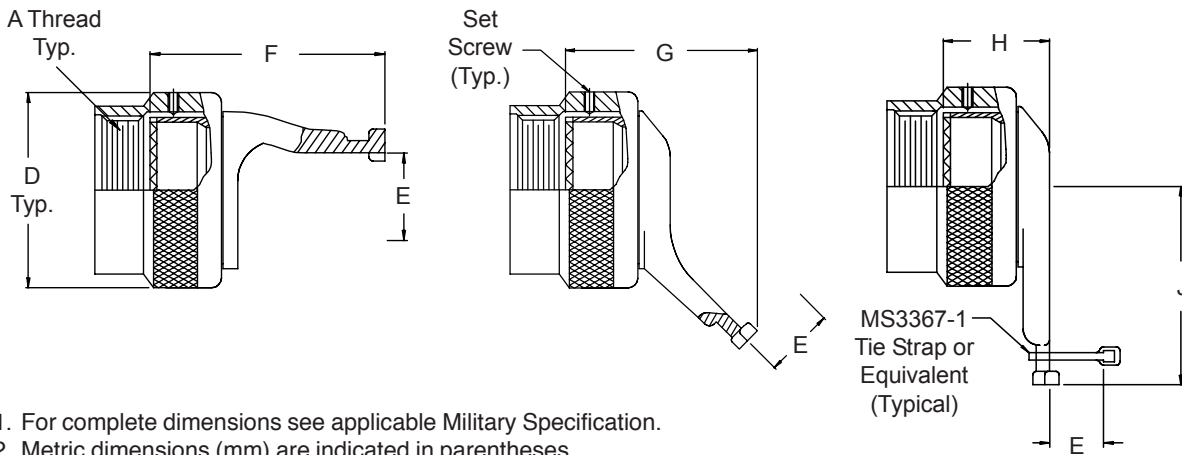

1. For complete dimensions see applicable Military Specification.
2. Metric dimensions (mm) are indicated in parentheses.
3. Cable entry is defined as the accommodation range for the wire bundle or cable. Dimensions shown are not intended for inspection criteria.

TABLE I

Shell Size	A Thread Class 2B	D Dia Max	E Max Cable Entry	F Max	G Max	H Max	J Max
08	.438 - 28 UNEF	.62 (15.7)	.240 (6.1)	1.06 (26.9)	.74 (18.8)	.71 (18.0)	.880 (22.4)
10	.500 - 28 UNEF	.73 (18.5)	.295 (7.5)	1.06 (26.9)	.74 (18.8)	.71 (18.0)	.940 (23.9)
11	.562 - 24 UNEF	.73 (18.5)	.375 (9.5)	1.06 (26.9)	.74 (18.8)	.71 (18.0)	.940 (23.9)
12	.625 - 24 UNEF	.86 (21.8)	.400 (10.2)	1.12 (28.4)	1.51 (38.4)	.71 (18.0)	1.000 (25.4)
13	.625 - 24 UNEF	.86 (21.8)	.400 (10.2)	1.12 (28.4)	.74 (18.8)	.71 (18.0)	1.000 (25.4)
14	.750 - 20 UNEF	.98 (24.9)	.482 (12.2)	1.30 (33.0)	2.01 (51.1)	.71 (18.0)	1.320 (33.5)
15	.750 - 20 UNEF	.98 (24.9)	.482 (12.2)	1.31 (33.3)	2.02 (51.3)	.71 (18.0)	1.320 (33.5)
16	.875 - 20 UNEF	1.11 (28.2)	.601 (15.3)	1.30 (33.0)	2.01 (51.1)	.71 (18.0)	1.370 (34.8)
17	.875 - 20 UNEF	1.11 (28.2)	.601 (15.3)	1.30 (33.0)	2.01 (51.1)	.71 (18.0)	1.370 (34.8)
18	1.000 - 20 UNEF	1.22 (31.0)	.722 (18.3)	1.36 (34.5)	2.17 (55.1)	.73 (18.5)	1.470 (37.3)
20	1.125 - 18 UNEF	1.35 (34.3)	.862 (21.9)	1.50 (38.1)	2.25 (57.2)	.74 (18.8)	1.510 (38.4)
22	1.250 - 18 UNEF	1.47 (37.3)	.970 (24.6)	1.62 (41.1)	2.25 (57.2)	.63 (16.0)	1.570 (39.9)
24	1.375 - 18 UNEF	1.59 (40.4)	1.082 (27.5)	1.68 (42.7)	2.33 (59.2)	.63 (16.0)	1.640 (41.7)
28	1.625 - 18 UNEF	1.97 (50.0)	1.241 (31.5)	1.71 (43.4)	2.33 (59.2)	.63 (16.0)	1.710 (43.4)

AS85049/15 and AS85049/16 Qwik-Ty® Strain Reliefs



Qwik-Ty®
Strain Reliefs

Glenair Connector
Designator H

MIL-DTL-38999
Series III & IV,
EN3645

Self-Locking
Coupling

M85049/15 G 11 W

Basic Part No.
M85049/15 = 45°
M85049/16 = 90°

Configuration
G = Self-Locking with
Ground Lug
S = Self-Locking without
Ground Lug

Finish
N = Electroless Nickel
W = 1,000 Hour Cadmium Olive Drab
Over Electroless Nickel

Shell Size

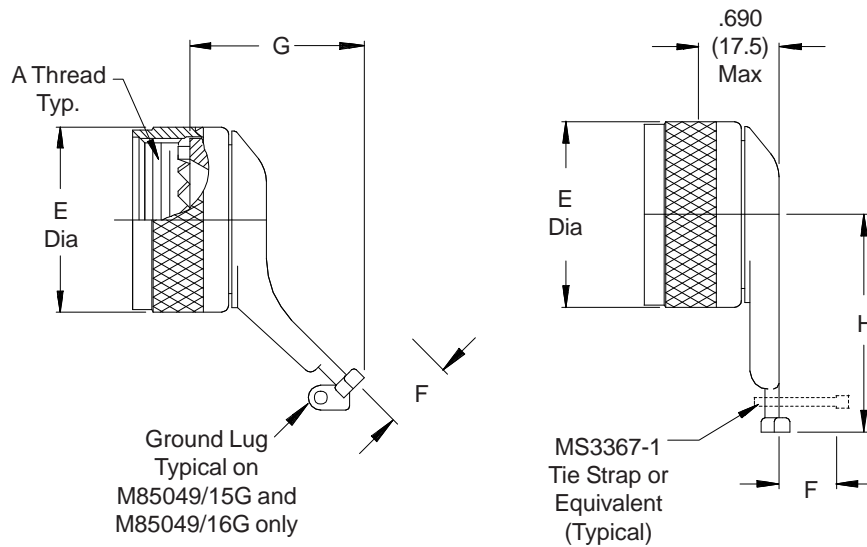

TABLE I

Shell Size	A Thread Class 2B	E Dia Max	F Max Cable Entry	M85049/15S G Max	M85049/15G G Max	M85049/16 H Max
9	M12 X 1 - 6H	.86 (21.8)	.264 (6.7)	1.03 (26.2)	1.21 (30.7)	1.22 (31.0)
11	M15 X 1 - 6H	.94 (23.9)	.392 (10.0)	1.03 (26.2)	1.21 (30.7)	1.29 (32.8)
13	M18 X 1 - 6H	1.16 (29.5)	.506 (12.9)	1.03 (26.2)	1.39 (35.3)	1.62 (41.1)
15	M22 X 1 - 6H	1.28 (32.5)	.631 (16.0)	1.09 (27.7)	1.39 (35.3)	1.66 (42.2)
17	M25 X 1 - 6H	1.41 (35.8)	.756 (19.2)	1.11 (28.2)	1.39 (35.3)	1.72 (43.7)
19	M28 X 1 - 6H	1.52 (38.6)	.845 (21.5)	1.21 (30.7)	1.39 (35.3)	1.72 (43.7)
21	M31 X 1 - 6H	1.64 (41.7)	.970 (24.6)	1.26 (32.0)	1.39 (35.3)	1.79 (45.5)
23	M34 X 1 - 6H	1.77 (45.0)	1.095 (27.8)	1.30 (33.0)	1.39 (35.3)	1.85 (47.0)
25	M37 X 1 - 6H	1.89 (48.0)	1.220 (31.0)	1.34 (34.0)	1.39 (35.3)	1.91 (48.5)

1. For complete dimensions see applicable Military Specification.
2. Metric dimensions (mm) are indicated in parentheses.



AS85049/53, AS85049/54, and AS85049/55 Qwik-Ty® Strain Reliefs

**Glenair Connector
Designator A**

**MIL-DTL-5015 Series 3400,
MIL-DTL-26482 Series 2,
AS81703 Series 3,
MIL-DTL-83723 Series I &
III, 40M39569, DEF 5326-3,
EN 2997, EN 3646,
ESC 10, ESC 11, LN 29504,
NFC93422 Series HE302,
PAN 6432-1, PAN 6432-2,
PATT 602**

M85049/55 G 22 W

Basic Part No. _____
 M85049/53 = Straight
 M85049/54 = 45°
 M85049/55 = 90°

Configuration _____
 G = Non-Self-Locking with
 Ground Lug (/55 Only)
 S = Self-Locking without
 Ground Lug (/55 Only)
 T = Self-Locking with Ground Lug
 Use Dash for Non-Self-Locking

Finish _____
 A = Black Anodize
 W = 1,000 Hr. Cadmium Olive
 Drab Over Electroless Nickel

Shell Size _____

**FOR NEW DESIGN
APPLICATIONS
USE M85049/43 (45°),
M85049/51 (90°), and
M85049/52 (Str.),**

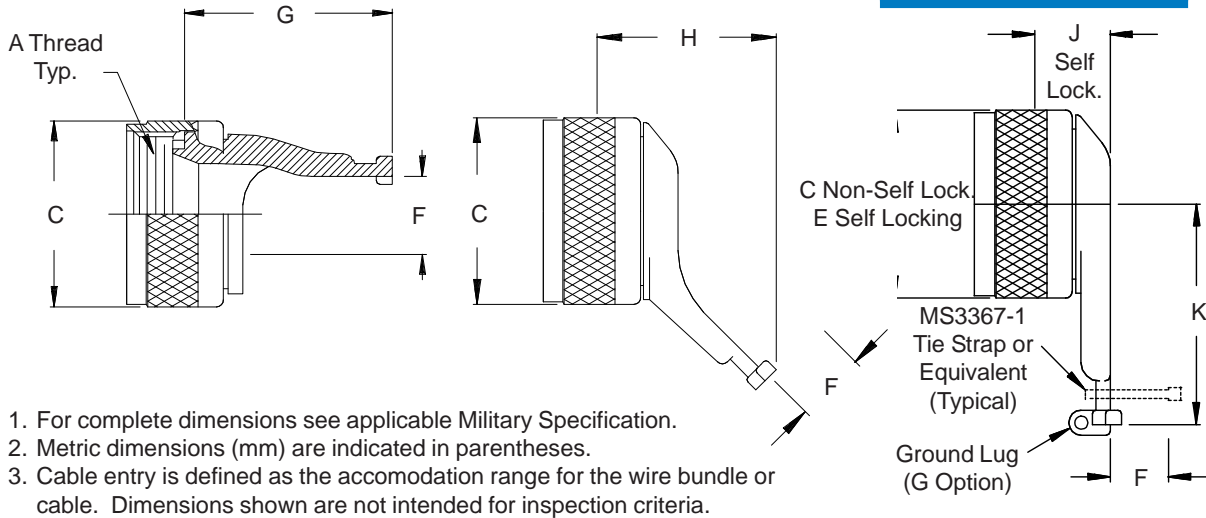

1. For complete dimensions see applicable Military Specification.
2. Metric dimensions (mm) are indicated in parentheses.
3. Cable entry is defined as the accommodation range for the wire bundle or cable. Dimensions shown are not intended for inspection criteria.

TABLE I								
Shell Size	A Thread Class 2B	C Dia Max	E Dia Max	F Cable Entry	G Max	H Max	J Max	K Max
03	.562 - 24 UNEF	.78 (19.8)	1.01 (25.7)	.260 (6.6)	.903 (22.9)	1.181 (30.0)	.73 (18.5)	1.29 (32.8)
08	.500 - 20 UNF	.66 (16.8)	.89 (22.6)	.260 (6.6)	.903 (22.9)	1.181 (30.0)	.73 (18.5)	1.29 (31.0)
10	.625 - 24 UNEF	.78 (19.8)	1.01 (25.7)	.365 (9.3)	.903 (22.9)	1.181 (30.0)	.73 (18.5)	1.29 (32.8)
12	.750 - 20 UNEF	.94 (23.9)	1.14 (29.0)	.501 (12.7)	.903 (22.9)	1.181 (30.0)	.73 (18.5)	1.62 (41.1)
14	.875 - 20 UNEF	1.05 (26.7)	1.26 (32.0)	.575 (14.6)	.973 (24.7)	1.181 (30.0)	.73 (18.5)	1.66 (42.2)
16	1.000 - 20 UNEF	1.24 (31.5)	1.39 (35.3)	.700 (17.8)	.973 (24.7)	1.181 (30.0)	.73 (18.5)	1.72 (43.7)
18	1.062 - 18 UNEF	1.38 (35.1)	1.51 (38.4)	.779 (19.8)	.973 (24.7)	1.181 (30.0)	.73 (18.5)	1.72 (43.7)
20	1.188 - 18 UNEF	1.50 (38.1)	1.64 (41.7)	.904 (23.0)	1.259 (32.0)	1.431 (36.3)	.75 (19.1)	1.79 (45.5)
22	1.313 - 18 UNEF	1.63 (41.4)	1.76 (44.7)	1.029 (26.1)	1.379 (35.0)	1.431 (36.3)	.75 (19.1)	1.85 (47.0)
24	1.438 - 18 UNEF	1.75 (44.5)	1.89 (48.0)	1.144 (29.1)	1.509 (38.3)	1.431 (36.3)	.75 (19.1)	1.91 (48.5)
28	1.750 - 18 UNS	1.97 (50.0)	2.14 (54.4)	1.379 (35.0)	1.509 (38.3)	1.418 (36.0)	.75 (19.1)	2.06 (52.3)

* Consult factory for availability

AS85049/56, AS85049/57, and AS85049/63 Qwik-Ty® Strain Reliefs



Qwik-Ty®
Strain Reliefs

**Glenair Connector
Designator F**

**MIL-DTL-38999 Series I &
II, 40M38277, PAN 6433-1,
PATT 614, PATT 616,
NFC93422 Series HE308 &
HE309**

M85049/63 G 16 W

Basic Part No. _____

M85049/56 = Straight
M85049/57 = 45°
M85049/63 = 90°

Configuration _____

G = Self-Locking with Ground
Lug (/57 and /63 Only)
S = Self-Locking without Ground
Lug (/57 and /63 Only)
Use Dash for Non-Self Locking

Finish _____

A = Black Anodize
N = Electroless Nickel
W = 1,000 Hr. Cadmium Olive Drab
Over Electroless Nickel

Shell Size _____

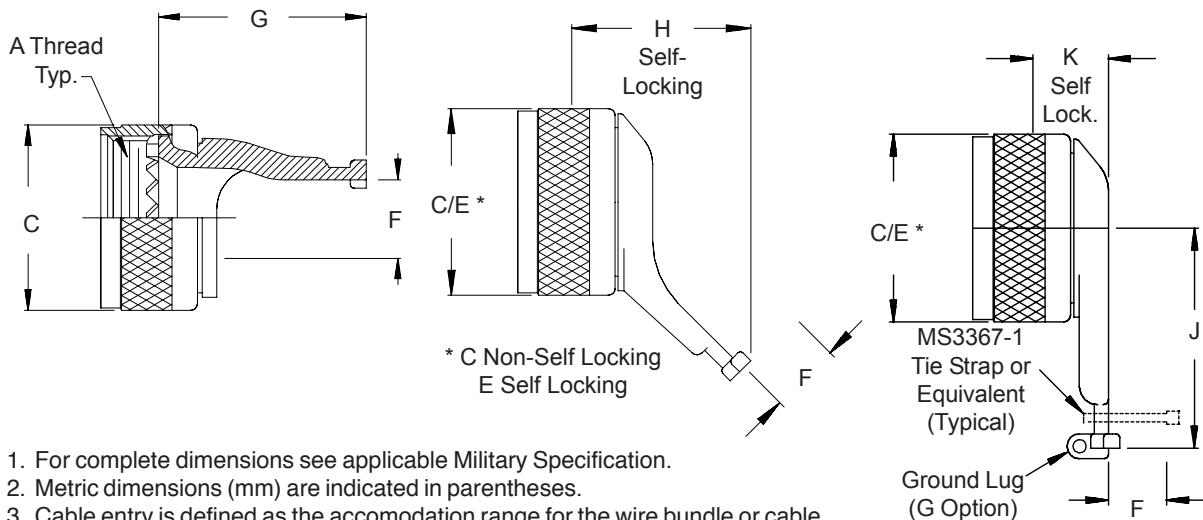

1. For complete dimensions see applicable Military Specification.
2. Metric dimensions (mm) are indicated in parentheses.
3. Cable entry is defined as the accommodation range for the wire bundle or cable. Dimensions shown are not intended for inspection criteria.

TABLE I

Shell Size	Ser. 1 Shell Ref.	A Thread Class 2B	C Dia Max	E Dia Max	F Max Cable Entry	G Max	H Max	J Max	K Max
8	9	.438-28 UNEF	.75 (19.1)	.86 (21.8)	.264 (6.7)	.895 (22.7)	1.21 (30.7)	1.22 (31.0)	.63 (16.0)
10	11	.562-24 UNEF	.85 (21.6)	.98 (24.9)	.392 (10.0)	.895 (22.7)	1.21 (30.7)	1.29 (32.8)	.63 (16.0)
12	13	.688-24 UNEF	1.00 (25.4)	1.16 (29.5)	.506 (12.9)	.955 (24.3)	1.39 (35.3)	1.62 (41.1)	.63 (16.0)
14	15	.813-20 UNEF	1.10 (27.9)	1.28 (32.5)	.631 (16.0)	1.135 (28.8)	1.39 (35.3)	1.66 (42.2)	.70 (17.8)
16	17	.938-20 UNEF	1.25 (31.8)	1.41 (35.8)	.756 (19.2)	1.135 (28.8)	1.39 (35.3)	1.72 (43.7)	.70 (17.8)
18	19	1.063-18 UNEF	1.40 (35.6)	1.52 (38.6)	.845 (21.5)	1.195 (30.4)	1.39 (35.3)	1.72 (43.7)	.73 (18.5)
20	21	1.188-18 UNEF	1.50 (38.1)	1.64 (41.7)	.970 (24.6)	1.325 (33.7)	1.39 (35.3)	1.79 (45.5)	.73 (18.5)
22	23	1.313-18 UNEF	1.65 (41.9)	1.77 (45.0)	1.095 (27.8)	1.445 (36.7)	1.39 (35.3)	1.85 (47.0)	.73 (18.5)
24	25	1.438-18 UNEF	1.75 (44.5)	1.89 (48.0)	1.220 (31.0)	1.585 (40.3)	1.39 (35.3)	1.91 (48.5)	.73 (18.5)

The Space Shuttle Orbiter escapes earth at the speed of 17,000 miles per hour.



But a damaged connector can scratch the mission in the blink of an eye.

Glenair's Sav-Con® Connector Savers are designed to mate with circular and rectangular Mil Spec connectors and test cables which are subject to repetitive mating cycles during manufacture and test. One of the most dramatic applications of our Sav-Con® connectors is on the Space Shuttle Orbiter where they provide protec-

tion for the umbilical connectors from lift-off to touch-down on every mission.

Glenair's Sav-Cons® are available in general duty, environmental and high-performance versions, and provide outstanding reliability and protection with only minimal affect on circuit resistance. Visit us at www.glenair.com for order information.



Commercial and Mil Spec connector accessories



Convolved tubing and metal-core conduit



Electrical and fiber optic cable assemblies



Composite thermoplastic components



Microminiature connectors and accessories



Backshell assembly and termination tools



1211 Air Way

Glendale, California 91201-2497

Telephone: 818-247-6000 · Facsimilie: 818-500-9912 · EMail: sales@glenair.com

United States · United Kingdom · Germany · Nordic · France · Italy · Spain

www.glenair.com

Rectangular Backshells



Rectangular
Backshells



Glenair's selection of rectangular backshells provide strain relief and environmental protection for rack and panel style connectors.

Military Specification	Superceding Part Number	Glenair's Commercial Catalog P/N	Description	Connector Interface	Page Number
M83733/15	M85049/28	**	EMI Rectangular Backshell	MIL-DTL-83733	50-2
M83733/16	M85049/44	**	Rectangular Strain Relief Backshell	MIL-DTL-83733	50-3
AS85049/28		**	EMI Rectangular Backshell	MIL-DTL-83733	50-2
AS85049/44		**	Rectangular Strain Relief Backshell	MIL-DTL-83733	50-3
AS85049/48-1		**	Rectangular Strain Relief Backshell	MIL-DTL-24308	50-4
AS85049/48-2		**	Rectangular Strain Relief Backshell	MIL-DTL-24308	50-5
AS85049/48-3		**	Rectangular Strain Relief Backshell	MIL-DTL-24308	50-6
AS85049/50		**	90° Rectangular Strain Relief Backshell	MIL-DTL-24308	50-7

** Consult Factory

AS85049/28 and M83733/15 Rectangular Backshells

Connector Interface
MIL-DTL-83733

M85049/28-2
Basic Part No. _____
Dash No. _____

Superceded Part Number

M83733/15-2
Basic Part No. _____
Dash No. _____

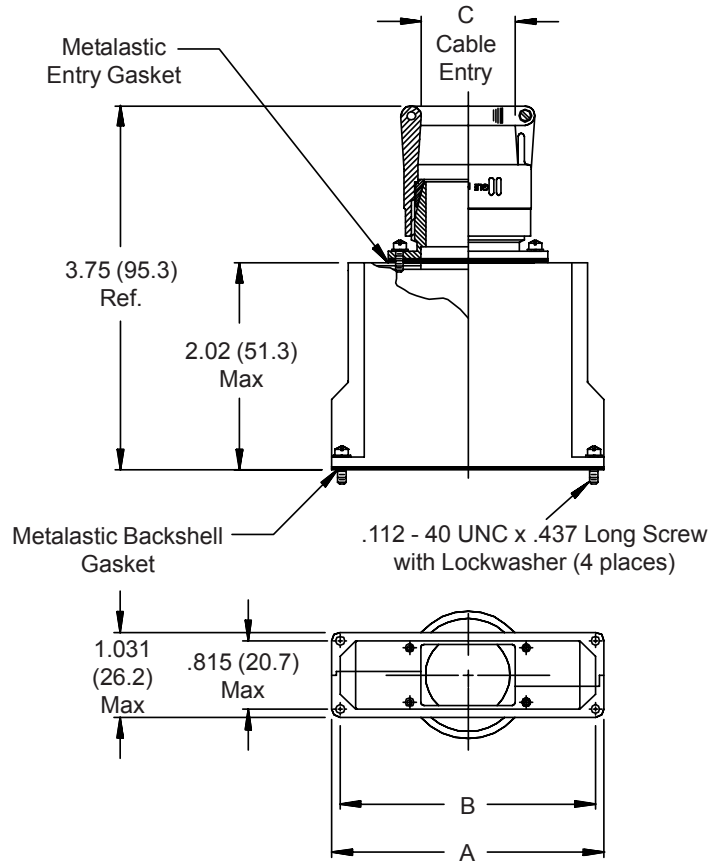

Dash No.	A Max	B Max	C Cable Entry	
			Min	Max
1	2.126 (54.0)	1.900 (48.3)	.500 (12.7)	.625 (15.9)
2	2.126 (54.0)	1.900 (48.3)	.625 (15.9)	.750 (19.1)
3	3.426 (87.0)	3.200 (81.3)	.500 (12.7)	.625 (15.9)
4	3.426 (87.0)	3.200 (81.3)	.625 (15.9)	.750 (19.1)

1. For complete dimensions see applicable Military Specification.
2. Metric dimensions (mm) are indicated in parentheses.
3. Cable entry is defined as the accomodation range for the wire bundle or cable. Dimensions shown are not intended for inspection criteria.

AS85049/44 and M83733/16 Rectangular Backshells



Rectangular
Backshells

Connector Interface MIL-DTL-83733

M85049/44-3
Basic Part No. _____
Dash No. _____

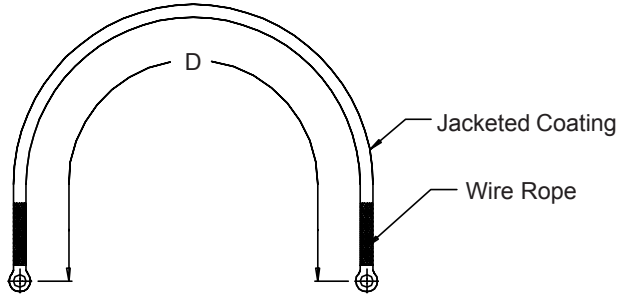

Superceded Part Number

M83733/16-3
Basic Part No. _____
Dash No. _____

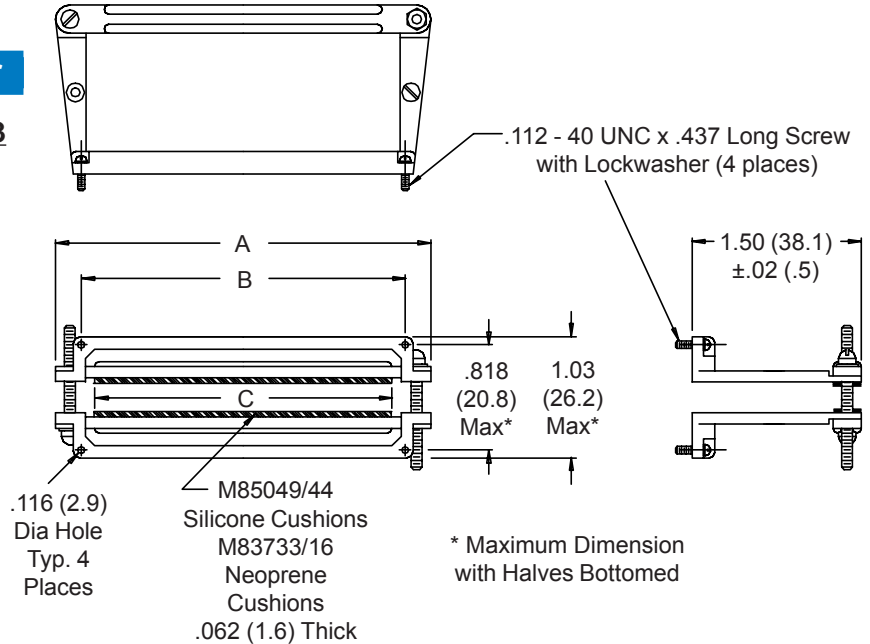

TABLE I

Dash No.	A ± .062 (1.57)	B ± .005 (.13)	C ± .062 (1.57)	D ± .062 (1.57)
1	2.437 (61.90)	1.895 (48.13)	1.700 (43.18)	*
2	3.750 (95.25)	3.195 (81.15)	3.000 (76.20)	*
3	2.437 (61.90)	1.895 (48.13)	1.700 (43.18)	10.375 (263.53)
4	3.750 (95.25)	3.195 (81.15)	3.000 (76.20)	10.375 (263.53)

* No Wire Rope Supplied

1. For complete dimensions see applicable Military Specification.
2. Metric dimensions (mm) are indicated in parentheses.

AS85049/48-1 Rectangular Backshells

**Connector Interface
MIL-DTL-24308**

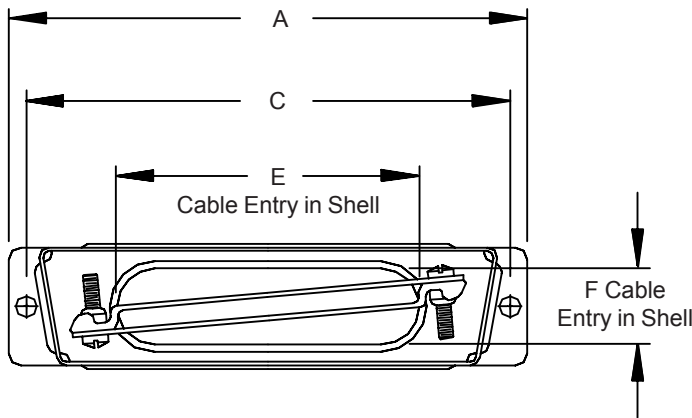

M85049/48-1-3 F

Basic Part No. _____

Dash No. _____

Finish _____

F = Yellow Chromate over Cadmium

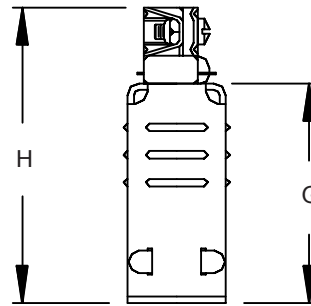
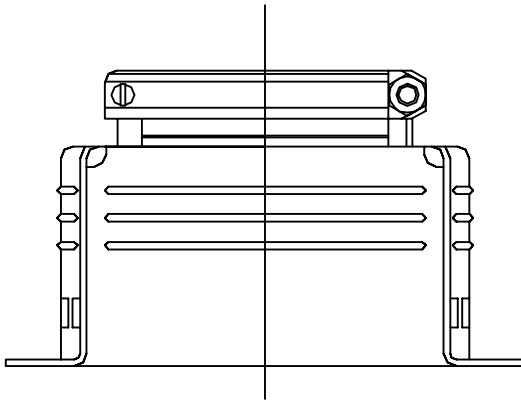

TABLE I											
Dash No.	A		C		E		F		G		H
	$\pm .015$	(0.4)	$\pm .005$	(.1)	$\pm .015$	(0.4)	$\pm .015$	(0.4)	$\pm .015$	(0.4)	Max
1	1.203	(30.6)	.984	(25.0)	.375	(9.5)	.375	(9.5)	.750	(19.1)	1.250 (31.8)
2	1.531	(38.9)	1.312	(33.3)	.713	(18.1)	.312	(7.9)	.750	(19.1)	1.250 (31.8)
3	2.078	(52.8)	1.852	(47.0)	1.000	(25.4)	.312	(7.9)	1.000	(25.4)	1.563 (39.7)
4	2.718	(69.0)	2.500	(63.5)	1.375	(34.9)	.312	(7.9)	1.000	(25.4)	1.563 (39.7)
5	2.625	(66.7)	2.406	(61.1)	1.406	(35.7)	.406	(10.3)	1.125	(28.6)	1.688 (42.9)

1. For complete dimensions see applicable Military Specification.
2. Metric dimensions (mm) are indicated in parentheses.
3. Material: Steel.

AS85049/48-2 Rectangular Backshells



Rectangular
Backshells

Connector Interface
MIL-DTL-24308

M85049/48-2-3 F

Basic Part No. _____
 Dash No. _____
 Finish _____
 F = Yellow Chromate over Cadmium

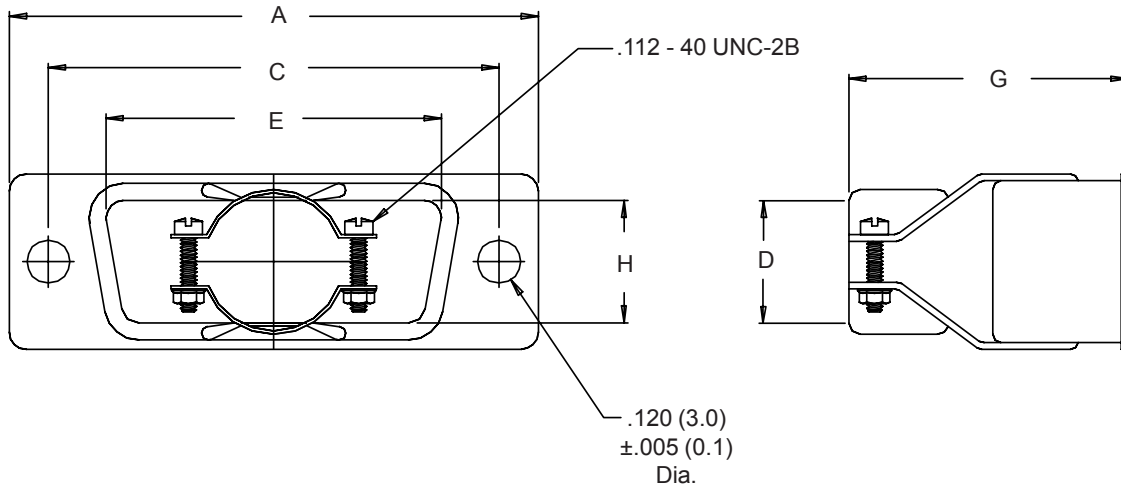

TABLE I

Dash No.	A ±.015 (0.4)	C ±.005 (.1)	D	E ±.015 (0.4)	G ±.030 (0.8)	H ±.015 (0.4)
1	1.208 (30.7)	.984 (25.0)	.406 (10.3)	.661 (16.8)	1.031 (26.2)	.344 (8.7)
2	1.531 (38.9)	1.312 (33.3)	.406 (10.3)	.984 (25.0)	1.031 (26.2)	.344 (8.7)
3	2.078 (52.8)	1.852 (47.0)	.593 (15.1)	1.515 (38.5)	1.062 (27.0)	.344 (8.7)
4	2.718 (69.0)	2.500 (63.5)	.718 (18.2)	2.171 (55.1)	1.062 (27.0)	.344 (8.7)
5	2.625 (66.7)	2.406 (61.1)	.812 (20.6)	2.093 (53.2)	1.062 (27.0)	.438 (11.1)

1. For complete dimensions see applicable Military Specification.
2. Metric dimensions (mm) are indicated in parentheses.
3. Material: Steel.

AS85049/48-3 Rectangular Backshells

**Connector Interface
MIL-DTL-24308**

M85049/48-3-3 F

Basic Part No. _____

Dash No. _____

Finish _____

F = Yellow Chromate over Cadmium

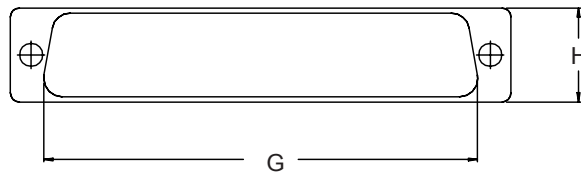
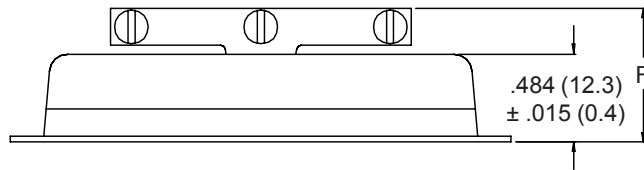
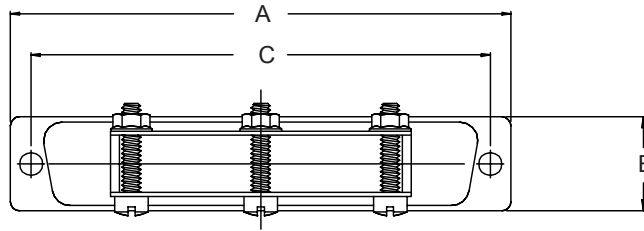

TABLE I										
Dash No.	# of Screws	A ±.015 (0.4)	B ±.015 (0.4)	C ±.005 (.1)	F Max	G ±.015 (0.4)	H ±.015 (0.4)			
2	2	1.531 (38.9)	.500 (12.7)	1.312 (33.3)	.679 (17.2)	1.091 (27.7)	.442 (11.2)			
3	2	2.078 (52.8)	.500 (12.7)	1.852 (47.0)	.679 (17.2)	1.631 (41.4)	.442 (11.2)			
4	3	2.718 (69.0)	.500 (12.7)	2.500 (63.5)	.679 (17.2)	2.282 (58.0)	.442 (11.2)			
5	3	2.625 (66.7)	.609 (15.5)	2.406 (61.1)	.703 (17.9)	2.205 (56.0)	.565 (14.4)			

1. For complete dimensions see applicable Military Specification.
2. Metric dimensions (mm) are indicated in parentheses.
3. Material: Steel.

AS85049/50 Rectangular Backshells



Rectangular
Backshells

Connector Interface
MIL-DTL-24308

M85049/50-3 F

Basic Part No. _____
Dash No. _____
Finish _____
F = Yellow Chromate over Cadmium

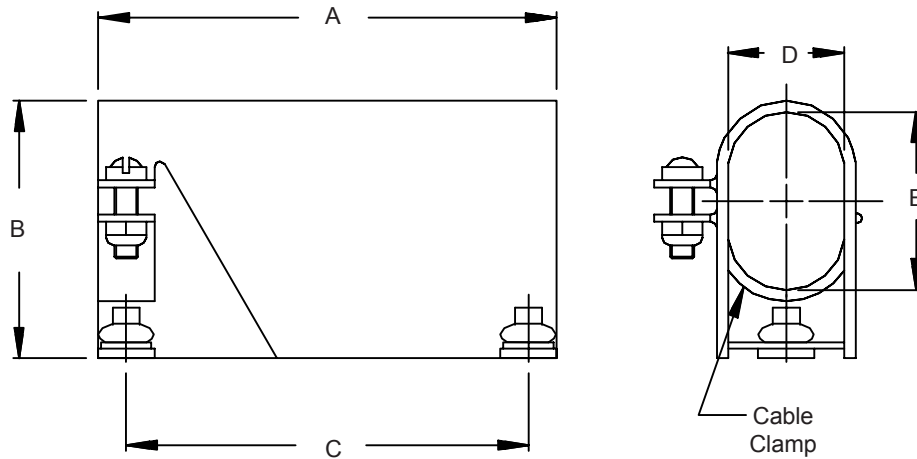
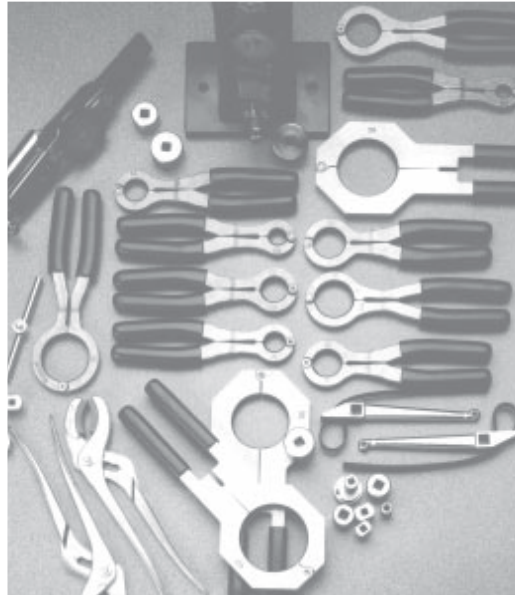

TABLE I

Dash No.	A ±.015 (0.4)	B ±.030 (0.8)	C ±.005 (0.1)	D Max	E ±.030 (0.8)
1	1.203 (30.6)	.718 (18.2)	.984 (25.0)	.467 (11.9)	.437 (11.1)
2	1.531 (38.9)	.718 (18.2)	1.312 (33.3)	.467 (11.9)	.437 (11.1)
3	2.078 (52.8)	.968 (24.6)	1.852 (47.0)	.467 (11.9)	.625 (15.9)
4	2.718 (69.0)	1.187 (30.1)	2.500 (63.5)	.467 (11.9)	.812 (20.6)
5	2.625 (66.7)	1.250 (31.8)	2.406 (61.1)	.592 (15.0)	.906 (23.0)

1. For complete dimensions see applicable Military Specification.
2. Metric dimensions (mm) are indicated in parentheses.
3. Material: Steel.

Stop Toolin' Around



Finding the right tool for the job just got a little bit easier

Nobody can grasp the ins-and-outs of interconnect tool design and manufacturing without a full understanding of cable harness assembly.

At Glenair, we not only manufacture the connectors, backshells, cables and enclosures which go into interconnect cable harnesses, we run a top-flight cable assembly service of our own. And we've drawn on this extensive experience to design and build a

complete family of specialized backshell assembly tools for most Mil-Standard circular connectors, as well as connector wrenches, mini-strap wrenches, universal connector holding tools and braid termination tools for production use and field maintenance.

Contact Glenair for more information or for a copy of our complete *Glenair Backshell Assembly Tools, Banding Tools and Accessories* Catalog.



1211 Air Way

Glendale, California 91201-2497

Telephone: 818-247-6000 · Facsimilie: 818-500-9912 · EMail: sales@glenair.com

United States · United Kingdom · Germany · Nordic · France · Italy · Spain

www.glenair.com



Mil-Spec Connector wrenches, plug and receptacle holders and accessories are required for expert assembly of interconnect systems. Glenair manufactures a wide range of connector wrenches and other assembly tools. Contact Glenair or your local sales representative for a copy of the *Glenair Backshell Assembly Tools, Banding Tools and Accessories* catalog.

Military Specification	Glenair's Commercial Catalog P/N	Description	Page Number
MS3480	TG38	Connector Wrench for MIL-DTL-5015 and MIL-DTL-83723 Series 2	60-2
MS3481	TG39	Connector Wrench for MIL-DTL-26482 Series 1 and 2, MIL-DTL-83723 Series I, and NAS 1599	60-3
MS3482	TG61	Connector Wrench MIL-C-81511 Series 1 and 3	60-4

MS3480-28

Basic Part No. _____ Dash No. _____

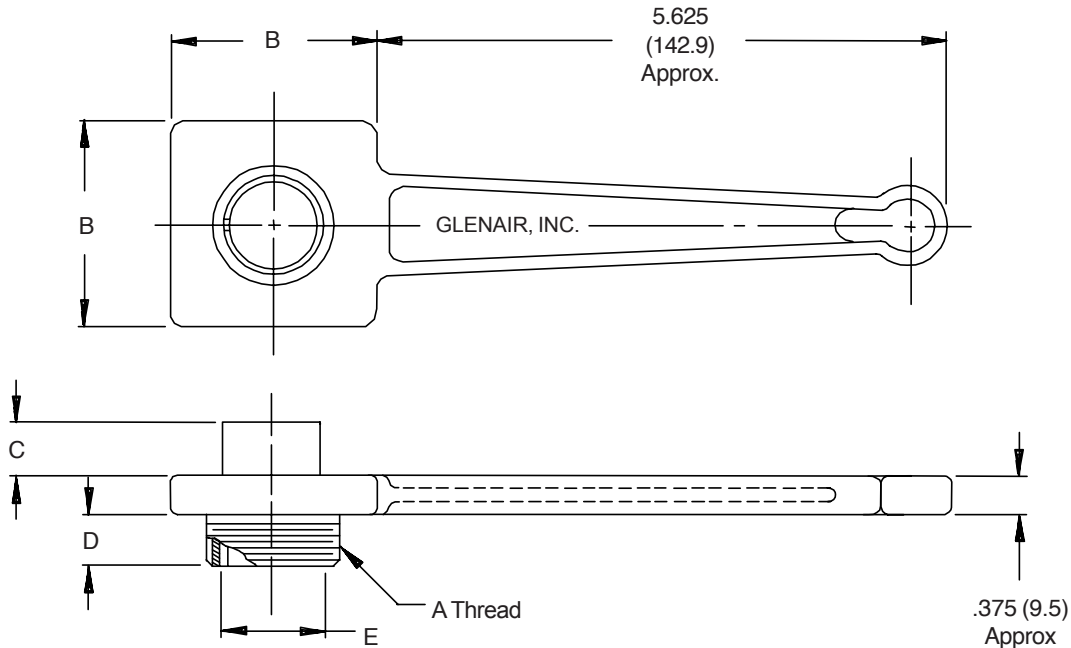
TABLE I

Dash No.	Shell Size	A Thread Class 2A	B Dia. ± .060 (1.5)	C Approx.	D Approx.	E +0 -.015 (.4)
8	8S	1/2 -28 UNEF	1.250 (31.8)	.718 (18.2)	.687 (17.4)	.370 (9.4)
10	10S, 10SL	5/8 -24 UNEF	1.250 (31.8)	.718 (18.2)	.687 (17.4)	.448 (11.4)
12	12, 12S	3/4 -20 UNEF	1.250 (31.8)	.921 (23.4)	.750 (19.1)	.557 (14.1)
14	14, 14S	7/8 -20 UNEF	1.250 (31.8)	.921 (23.4)	.750 (19.1)	.682 (17.3)
16	16, 16S	1 -20 UNEF	2.000 (50.8)	.921 (23.4)	.750 (19.1)	.807 (20.5)
18	18	1 1/8 -18 UNEF	2.000 (50.8)	.921 (23.4)	.750 (19.1)	.932 (23.7)
20	20	1 1/4 -18 UNEF	2.000 (50.8)	.921 (23.4)	.750 (19.1)	1.058 (26.9)
22	22	1 3/8 -18 UNEF	2.000 (50.8)	.921 (23.4)	.750 (19.1)	1.182 (30.0)
24	24	1 1/2 -18 UNEF	2.000 (50.8)	.921 (23.4)	.750 (19.1)	1.307 (33.2)
28	28	1 3/4 -18 UNS	2.750 (69.9)	.921 (23.4)	.750 (19.1)	1.526 (38.8)
32	32	2 -18 UNS	2.750 (69.9)	.921 (23.4)	.750 (19.1)	1.776 (45.1)
36	36	2 1/4 -16 UN	2.750 (69.9)	.921 (23.4)	.750 (19.1)	1.995 (50.7)
40	40	2 1/2 -16 UN	2.750 (69.9)	.921 (23.4)	.750 (19.1)	2.245 (57.0)

1. For complete dimensions see applicable Military Specification.
2. Metric dimensions (mm) are indicated in parentheses.
3. Material: Aluminum alloy with electroless nickel finish.

**MS3481 - Connector Wrench
MIL-DTL-26482 Series I and II,
MIL-DTL-83723 Series I, and NAS 1599**



Tools

MS3481-20

Basic Part No. _____ Dash No. _____

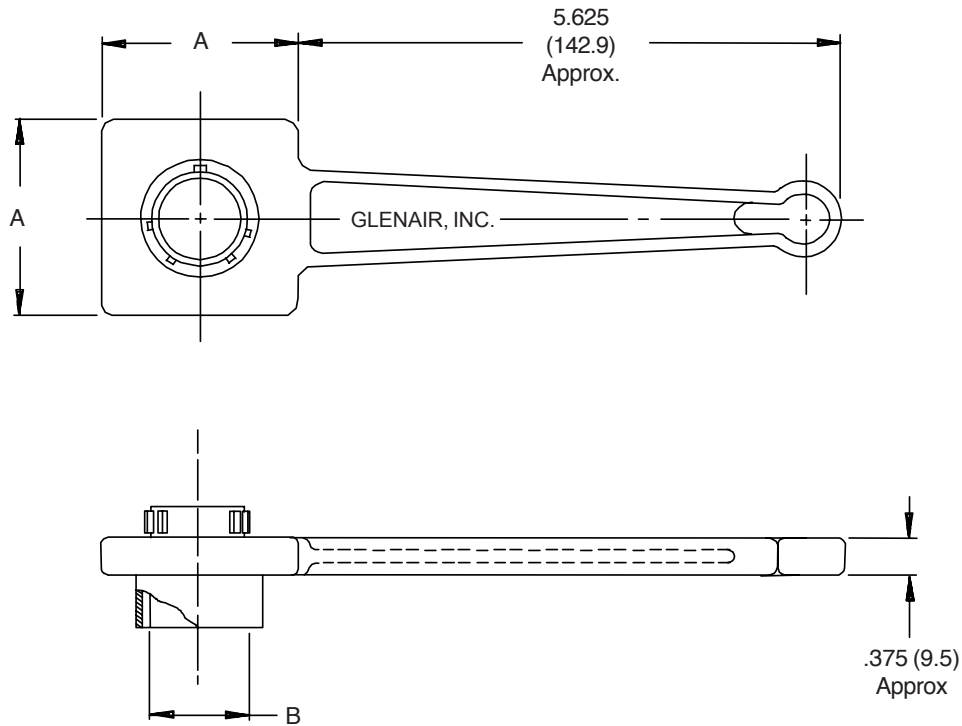

TABLE I

Shell Size	A Dim.		B Dia.	
	± .060	(1.5)	Ref.	
8	1.250	(31.8)	.362	(9.2)
10	1.250	(31.8)	.490	(12.4)
12	1.250	(31.8)	.607	(15.4)
14	1.250	(31.8)	.732	(18.6)
16	2.000	(50.8)	.857	(21.8)
18	2.000	(50.8)	.962	(24.4)
20	2.000	(50.8)	1.087	(27.6)
22	2.000	(50.8)	1.212	(30.8)
24	2.000	(50.8)	1.337	(34.0)

1. For complete dimensions see applicable Military Specification.
2. Metric dimensions (mm) are indicated in parentheses.
3. Material: Aluminum alloy with electroless nickel finish.

MS3482-18-6

Basic Part No. _____ Polarization Position
 (1, 2, 3, 4, 5, 6)
 Dash No. _____

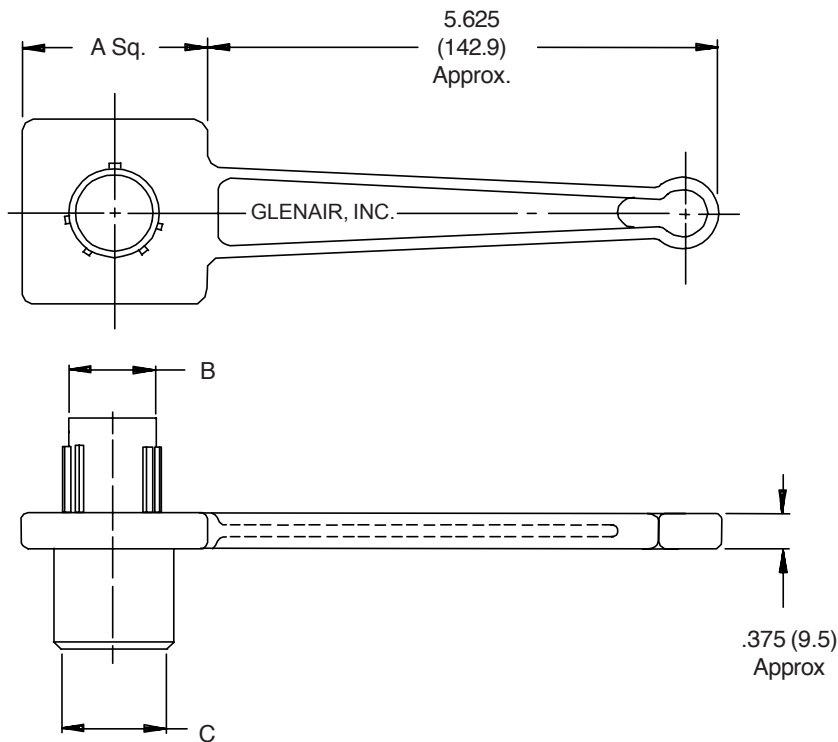
TABLE I

Shell Size	A Dim. ±.060 (1.5)	B Dia.		C Dia. ±.003 (.1)
		+001 (.1)	-.008 (.2)	
8	1.250 (31.8)	.381 (9.7)	.389 (9.9)	
10	1.250 (31.8)	.506 (12.9)	.514 (13.1)	
14	2.000 (50.8)	.756 (19.2)	.764 (19.4)	
16	2.000 (50.8)	.882 (22.4)	.890 (22.6)	
18	2.000 (50.8)	1.006 (25.6)	1.014 (25.8)	

1. For complete dimensions see applicable Military Specification.
2. Metric dimensions (mm) are indicated in parentheses.
3. Material: Aluminum alloy with electroless nickel finish.



This section describes the various backshells without strain relief for use with circular connectors. (These are most commonly referred to as "E" Nuts.)

Military Specification	Superceding Part Number	Glenair's Commercial Catalog P/N	Description	Connector Designator	Page Number
MS3416E	M85049/31	610AS011	E Nut	A	61-7
M28840/23		**	E Nut	G	61-2
M38999/1	M85049/27	610FS011	E Nut	F	61-6*
M81511/16		610JS012	E Nut	J	61-3
M83723/15N	M85049/31	610AS011	E Nut	A	61-7
M83723/35N		**	E Nut	K	61-4
AS85049/14S		**	E Nut, Self-Locking	H	61-5
AS85049/27		610FS011	E Nut	F	61-6
AS85049/27S		**	E Nut, Self-Locking	F	61-6
AS85049/31		610AS011	E Nut	A	61-7
AS85049/31S		**	E Nut, Self-Locking	A	61-7

* Page Number of Superceding Part Number
 ** Consult Factory

**Glenair Connector
Designator G**

MIL-C-28840

M28840/23 J W

Basic Part No.

Shell Size

Material and Finish

W = Aluminum, Cadmium Olive
Drab over Electroless Nickel

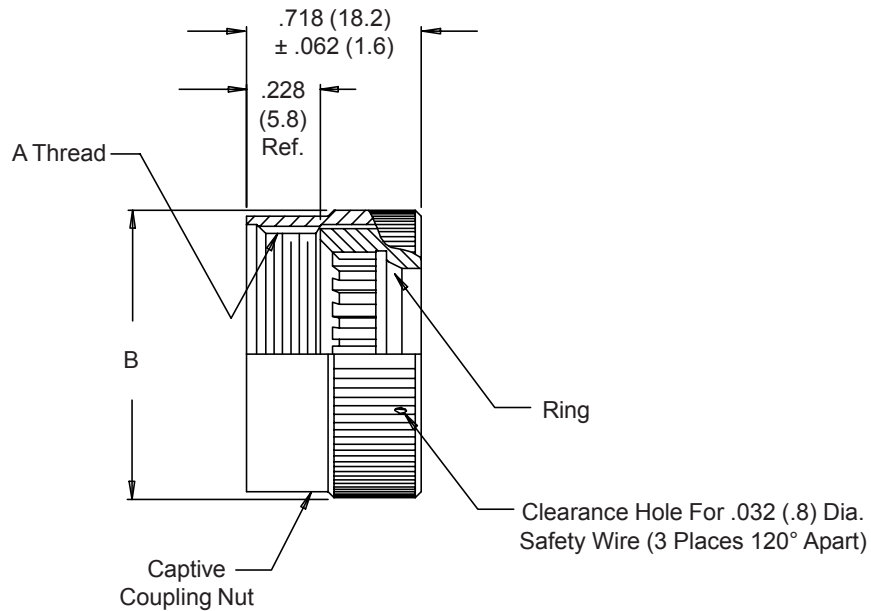

TABLE I

Shell Size	Shell Size Ref.	A Thread Class 2B	B Dia Max
A	11	.750 - 20 UNEF	1.028 (26.1)
B	13	.875 - 20 UNEF	1.141 (29.0)
C	15	1.000 - 20 UNEF	1.263 (32.1)
D	17	1.125 - 18 UNEF	1.387 (35.2)
E	19	1.250 - 18 UNEF	1.513 (38.4)
F	23	1.438 - 18 UNEF	1.703 (43.3)
G	25	1.562 - 18 UNEF	1.825 (46.4)
H	29	1.875 - 16 UN	2.143 (54.4)
J	33	2.062 - 16 UNS	2.329 (59.2)

1. For complete dimensions see applicable Military Specification.
2. Metric dimensions (mm) are indicated in parentheses.

**M81511/16
"E" Nuts**



"E" Nuts

Glenair Connector
Designator J

MIL-C-81511

M81511/16-10

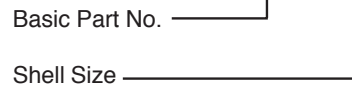

Inactive for New Design

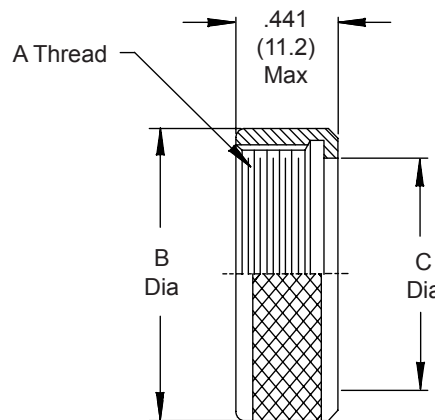

TABLE I			
Shell Size	A Thread Class 2B	B Dia ±.010 (.3)	C Dia ±.005 (.1)
08	.500 - 28 UNEF	.542 (13.8)	.295 (7.5)
10	.625 - 28 UN	.669 (17.0)	.420 (10.7)
14	.875 - 28 UN	.915 (23.2)	.670 (17.0)
16	1.000 - 28 UN	1.043 (26.5)	.794 (20.2)
18	1.125 - 28 UN	1.169 (29.7)	.930 (23.6)

1. For complete dimensions see applicable Military Specification.
2. Metric dimensions (mm) are indicated in parentheses.
3. Material is 103 nylon plastic (black).

Glenair Connector
Designator K

MIL-DTL-83723 Series II

M83723/35N 22 A

Basic Part No.

Dash No.

Finish

A = Black Anodize

R = Electroless Nickel

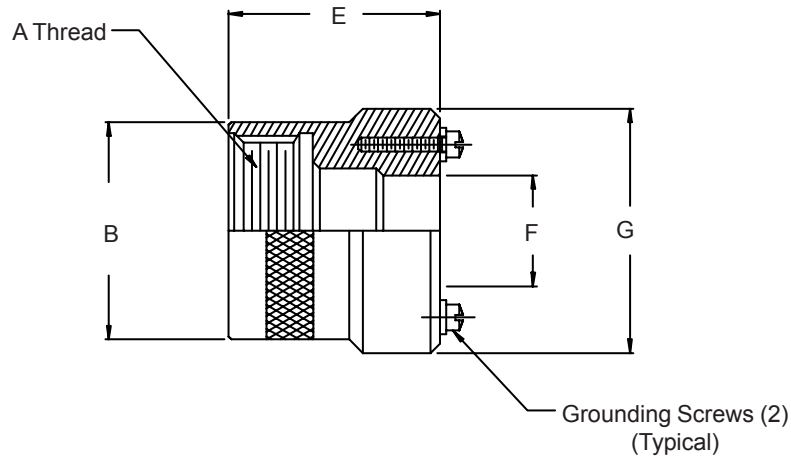

TABLE I

Shell Size	Shell Size Ref.	A Thread Class 2B	B Dia Max	E Max	F Max	G Max
08	8S	.438 - 28 UNEF	.59 (15.0)	.780 (19.8)	.257 (6.5)	.900 (22.9)
10	10S	.500 - 28 UNEF	.65 (16.5)	.780 (19.8)	.310 (7.9)	.900 (22.9)
11	10SL	.562 - 24 UNEF	.73 (18.5)	.780 (19.8)	.390 (9.9)	.980 (24.9)
13	12S	.625 - 24 UNEF	.77 (19.6)	.780 (19.8)	.415 (10.5)	.995 (25.3)
15	14S	.750 - 20 UNEF	.91 (23.1)	.780 (19.8)	.497 (12.6)	1.160 (29.5)
16	16	.875 - 20 UNEF	1.03 (26.2)	.970 (24.6)	.616 (15.6)	1.260 (32.0)
17	16S	.875 - 20 UNEF	1.03 (26.2)	.780 (19.8)	.616 (15.6)	1.260 (32.0)
18	18	1.000 - 20 UNEF	1.17 (29.7)	1.050 (26.7)	.735 (18.7)	1.455 (37.0)
20	20	1.125 - 18 UNEF	1.30 (33.0)	1.050 (26.7)	.875 (22.2)	1.580 (40.1)
22	22	1.250 - 18 UNEF	1.42 (36.1)	1.050 (26.7)	.983 (25.0)	1.580 (40.1)
24	24	1.375 - 18 UNEF	1.54 (39.1)	.970 (24.6)	1.095 (27.8)	1.890 (48.0)
28	28	1.625 - 18 UNEF	1.80 (45.7)	.970 (24.6)	1.255 (31.9)	1.890 (48.0)
32	32	1.875 - 16 UN	2.04 (51.8)	.970 (24.6)	1.525 (38.7)	2.215 (56.3)
36	36	2.125 - 16 UN	2.27 (57.7)	.970 (24.6)	1.760 (44.7)	2.405 (61.1)
40	40	2.375 - 16 UN	2.78 (70.6)	1.450 (36.8)	2.020 (51.3)	2.781 (70.6)

1. For complete dimensions see applicable Military Specification.
2. Metric dimensions (mm) are indicated in parentheses.

AS85049/14S
"E" Nuts



"E" Nuts

Glenair Connector
Designator H

MIL-DTL-38999
Series III & IV,
EN3645

M85049/14S 11 W

Basic Part No. _____
Shell Size _____

Finish
N = Electroless Nickel
W = 1,000 Hr. Cadmium Olive Drab
Over Electroless Nickel

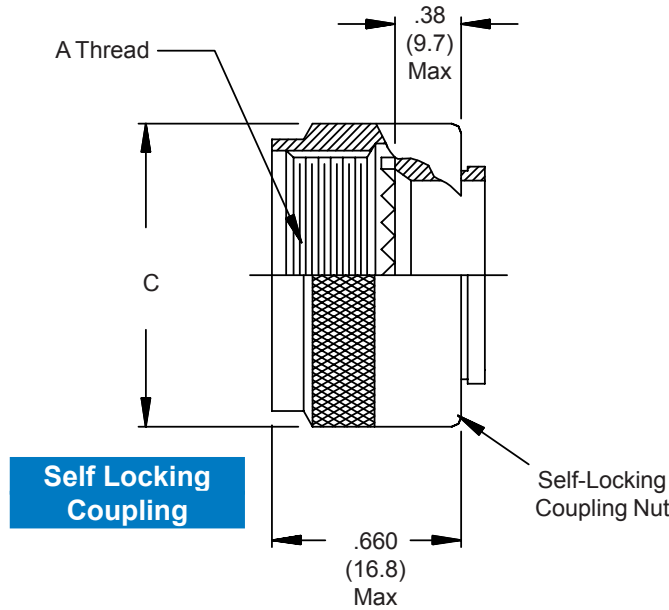

TABLE I

Shell Size	Shell Size Code Ref.	A Thread Class 2B	C Dia Max
9	A	M12 X 1 - 6H	.86 (21.8)
11	B	M15 X 1 - 6H	.94 (23.9)
13	C	M18 X 1 - 6H	1.16 (29.5)
15	D	M22 X 1 - 6H	1.28 (32.5)
17	E	M25 X 1 - 6H	1.41 (35.8)
19	F	M28 X 1 - 6H	1.52 (38.6)
21	G	M31 X 1 - 6H	1.64 (41.7)
23	H	M34 X 1 - 6H	1.77 (45.0)
25	J	M37 X 1 - 6H	1.89 (48.0)

1. For complete dimensions see applicable Military Specification.
2. Metric dimensions (mm) are indicated in parentheses.

Glenair Connector
Designator F

MIL-DTL-38999 Series I & II,
40M38277, PAN 6433-1, PATT
614, PATT 616,
NFC93422 Series HE308 &
HE309

M85049/27 S 10 N

Basic Part No.

S = Self-Locking
Use Dash (-) for
Non-Self Locking

Finish

N = Electroless Nickel
W = 1,000 Hr. Cadmium Olive Drab
Over Electroless Nickel

Shell Size

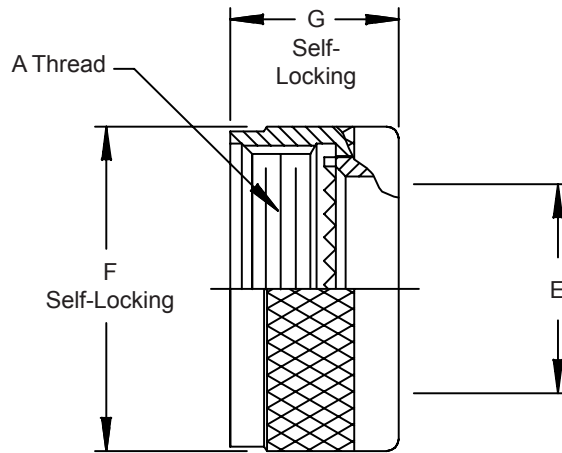

TABLE I

Shell Size	A Thread Class 2B	E Dia Max	F Dia Max	G Max
8	.438 - 28 UNEF	.274 (7.0)	.859 (21.8)	.590 (15.0)
10	.562 - 24 UNEF	.412 (10.5)	.984 (25.0)	.590 (15.0)
12	.688 - 24 UNEF	.526 (13.4)	1.156 (29.4)	.590 (15.0)
14	.813 - 20 UNEF	.651 (16.5)	1.281 (32.5)	.590 (15.0)
16	.938 - 20 UNEF	.776 (19.7)	1.406 (35.7)	.590 (15.0)
18	1.063 - 18 UNEF	.882 (22.4)	1.516 (38.5)	.590 (15.0)
20	1.188 - 18 UNEF	1.006 (25.6)	1.641 (41.7)	.590 (15.0)
22	1.313 - 18 UNEF	1.132 (28.8)	1.766 (44.9)	.590 (15.0)
24	1.438 - 18 UNEF	1.257 (31.9)	1.891 (48.0)	.590 (15.0)

1. For complete dimensions see applicable Military Specification.
2. Metric dimensions (mm) are indicated in parentheses.

AS85049/31, MS3416 E and M83723/15N "E" Nuts



"E" Nuts

Glenair Connector Designator A

MIL-DTL-5015 Series 3400,
MIL-DTL-26482 Series 2,
AS81703 Series 3,
MIL-DTL-83723 Series I &
III, 40M39569, DEF 5326-3,
EN 2997, EN 3646,
ESC 10, ESC 11, LN 29504,
NFC93422 Series HE302,
PAN 6432-1, PAN 6432-2,
PATT 602

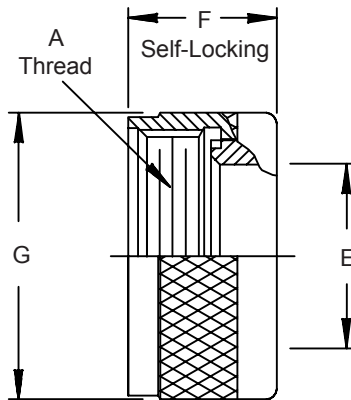

M85049/31 S 22 N

Basic Part No. ————
S = Self-Locking ————
Use Dash (-) for
Non-Self Locking ————
Finish
A = Black Anodize
N = Electroless Nickel
W = 1,000 Hr. Cadmium Olive
Drab Over Electroless Nickel
Shell Size

MS3416-10 E A

Basic Part No. ————
(Non-Self-Locking Only)
Dash No. ————
Style ————
SUPERCEDED SPEC.
Material and Finish Designator
A = Aluminum, 500 Hour Cad. Olive
Drab Over Electroless Nickel
C = Aluminum, Cadmium Olive Drab
G = Aluminum, Black Anodize
N = Aluminum, Electroless Nickel

M83723/15N-10 A

Basic Part No. ————
(Non-Self-Locking Only)
Dash No. ————
SUPERCEDED SPEC.
Finish Designator
A = Non-Conductive, Black Anodize
R = Conductive, Electroless Nickel

TABLE I

Shell Size	A Thread Class 2B	E Dia Max	F Max	G Dia Max
3	.562 - 24 UNEF	.270 (6.9)	--	--
8	.500 - 20 UNF	.270 (6.9)	.710 (18.0)	.885 (22.5)
10	.625 - 24 UNEF	.375 (9.5)	.710 (18.0)	1.010 (25.7)
12	.750 - 20 UNEF	.511 (13.0)	.710 (18.0)	1.135 (28.8)
14	.875 - 20 UNEF	.585 (14.9)	.710 (18.0)	1.260 (32.0)
16	1.000 - 20 UNEF	.710 (18.0)	.710 (18.0)	1.385 (35.2)
18	1.062 - 18 UNEF	.789 (20.0)	.710 (18.0)	1.510 (38.4)
20	1.188 - 18 UNEF	.914 (23.2)	.710 (18.0)	1.635 (41.5)
22	1.313 - 18 UNEF	1.039 (26.4)	.710 (18.0)	1.760 (44.7)
24	1.438 - 18 UNEF	1.154 (29.3)	.710 (18.0)	1.885 (47.9)
28	1.750 - 18 UNS	1.389 (35.3)	.890 (22.6)	2.135 (54.2)
32	2.000 - 18 UNS	1.635 (41.5)	.890 (22.6)	2.395 (60.8)
36	2.250 - 16 UN	1.850 (47.0)	.890 (22.6)	2.635 (66.9)
40	2.500 - 16 UN	2.065 (52.5)	.890 (22.6)	2.885 (73.3)
44	2.750 - 16 UN	2.320 (58.9)	.890 (22.6)	3.135 (79.6)
48	3.000 - 16 UN	2.570 (65.3)	.890 (22.6)	3.385 (86.0)
61	1.500 - 18 UNEF	1.194 (30.3)	--	--

1. For complete dimensions see applicable Military Specification.
2. Metric dimensions (mm) are indicated in parentheses.

It's cold. It's wet.
It's out in the middle of nowhere.



Just the Place for Glenair's Geo-Marine® Connectors and Cables.

Designed for use in oceanographic, geophysical and other severe environments, Glenair's line of Geo-Marine® connectors and cables withstand hydrostatic pressures up to 5,000 psi and exposure to extreme temperatures and

corrosives. Our Geo-Marine® products have been used in offshore oil drilling, seabed exploration, and pipeline inspection systems, and are available as either discrete connectors, accessories and cable or as engineered cable assemblies.



Geo-Marine® connectors and cables



Geo-Marine® connectors & Bulkhead feed-throughs



Complete molded Geo-Marine® cable assemblies



Geo-Marine® castellated and knurled coupling rings



Nickel aluminum bronze & stainless steel construction



High-density Geo-Marine® insert arrangements



1211 Air Way
Glendale, California 91201-2497
Telephone: 818-247-6000 · Facsimilie: 818-500-9912 · EMail: sales@glenair.com

United States · United Kingdom · Germany · Nordic · France · Italy · Spain
www.glenair.com

Strain Reliefs



Strain
Reliefs



Glenair offers a comprehensive selection of strain reliefs for circular connectors. Straight and angular versions are offered for most connector series.

Military Specification	Superceeding Part Number	Glenair's Commercial Catalog P/N	Description	Connector Interface or Designator	Page Number
MS3057A	M85049/41	620-053 Style A	Straight Strain Relief	***	62-13
MS3057B	M85049/1	620-053 Style B	Straight Strain Relief	***	62-9
MS3057C	M85049/2	620-053 Style C	Straight Strain Relief	***	62-10
MS3057D	M85049/42	620-053 Style H	Straight Strain Relief	***	62-14
MS3415	M85049/43	620AB047	45° Strain Relief	***	62-15*
MS3417	M85049/52-1	620AS046	Straight Strain Relief	A	62-22
MS3418	M85049/51-1	620AA046	90° Strain Relief	A	62-20
MS27291		620ES050	Straight Strain Relief	E	62-2
MS27342-2	M85049/49-2	**	Straight Strain Relief	F	62-19*
MS27506	M85049/49-2	620FS054	Straight Strain Relief	F	62-19*
MS27507	M85049/47	620FA012	90° Strain Relief	F	62-18
MS27558		**	90° Strain Relief	E	62-3
MS27559		**	90° Strain Relief	E	62-4
M28840/1		620GS051	Straight Strain Relief	G	62-5
M28840/2		620GA051	90° Strain Relief	G	62-6
M28840/3		620GB051	45° Strain Relief	G	62-7
M81511/13		620JS001	Straight Strain Relief	J	62-8
M83723/15A	M85049/51-1	620AA046	90° Strain Relief	A	62-20
M83723/15S	M85049/52-1	620AS046	Straight Strain Relief	A	62-22
AS85049/1		620-053 Style B	Strain Relief	***	62-9
AS85049/2		620-053 Style C	Strain Relief	***	62-10
AS85049/38		620HS011	Straight Strain Relief	H	62-11
AS85049/38S		620HS048	Straight Strain Relief, Self-Locking	H	62-11
AS85049/38SS		**	Straight Strain Relief, Self-Locking (Steel)	H	62-11
AS85049/39		620HA011	90° Strain Relief	H	62-12
AS85049/39S		620HA048	90° Strain Relief, Self-Locking	H	62-12
AS85049/39SS		**	90° Strain Relief, Self-Locking (Steel)	H	62-12
AS85049/41		620-053 Style A	Straight Strain Relief	***	62-13
AS85049/42		620-053 Style H	Straight Strain Relief	***	62-14
AS85049/43		620AB047	45° Strain Relief	A	62-15
AS85049/45		**	Straight Strain Relief	F	62-16
AS85049/46		**	90° Strain Relief	F	62-17
AS85049/47		620FA012	90° Strain Relief	F	62-18
AS85049/47S		620FA048	90° Strain Relief, Self Locking	F	62-18
AS85049/47SS		620FA048Z1	90° Strain Relief, Self Locking (Steel)	F	62-18
AS85049/49-2		620FS012	Straight Strain Relief	F	62-19
AS85049/49-2S		620FS048	Straight Strain Relief, Self-Locking	F	62-19
AS85049/49-2SS		620FS048Z1	Straight Strain Relief, Self-Locking (Steel)	F	62-19
AS85049/51-1		620AA046	90° Strain Relief	A	62-20
AS85049/51S		620AA048	90° Strain Relief, Self-Locking	A	62-20
AS85049/52-1		620AS046	Straight Strain Relief	A	62-22
AS85049/52S		620AS048	Straight Strain Relief, Self-Locking	A	62-22
AS85049/91		620HS042	Straight Strain Relief, Composite Material	H	62-24
AS85049/92		620HA042	90° Strain Relief, Composite Material	H	62-24

*Page Number of Superceeding Part Number

**Consult Factory

***MS "V" Thread - General Duty "A" End Bell

Glenair Connector
Designator E

MIL-DTL-26500

MS27291-401

Basic Part No.

Dash No.

**INACTIVE FOR
NEW DESIGN OR
MODIFICATION
OF EXISTING
EQUIPMENT**

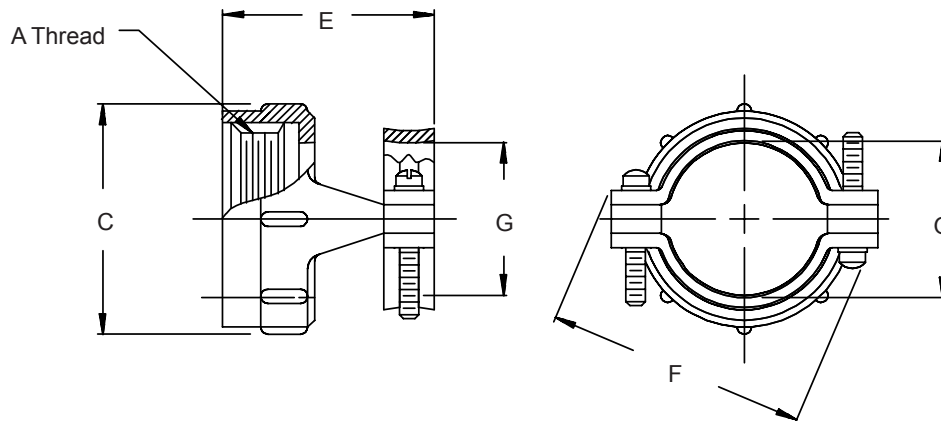

TABLE I

Dash No. For Use With Class Connectors		Shell Size	A Thread	C	E	F	G
R and F	G	Ref.	Class 2B	Max	± 0.015 (.4)	Max	± 0.005 (.1) Dia
1	101	10	.562 - 24 UNEF	.731 (18.6)	.935 (23.7)	.914 (23.2)	.270 (6.9)
2	201	12	.750 - 20 UNEF	.919 (23.3)	.935 (23.7)	1.026 (26.1)	.400 (10.2)
3	301	14	.812 - 20 UNEF	.981 (24.9)	1.170 (29.7)	1.090 (27.7)	.460 (11.7)
4	401	16	.938 - 20 UNEF	1.106 (28.1)	1.170 (29.7)	1.250 (31.8)	.610 (15.5)
5	501	18	1.062 - 18 UNEF	1.231 (31.3)	1.170 (29.7)	1.358 (34.5)	.690 (17.5)
6	601	22	1.312 - 18 UNEF	1.481 (37.6)	1.170 (29.7)	1.604 (40.7)	.940 (23.9)
13	701	8	.438 - 28 UNEF	.606 (15.4)	.935 (23.7)	.789 (20.0)	.186 (4.7)
14	801	20	1.188 - 18 UNEF	1.356 (34.4)	1.170 (29.7)	1.481 (37.6)	.816 (20.7)
15	901	24	1.438 - 18 UNEF	1.606 (40.8)	1.170 (29.7)	1.729 (43.9)	1.066 (27.1)

1. For complete dimensions see applicable Military Specification.
2. Metric dimensions (mm) are indicated in parentheses.
3. Finish: Anodize.

MS27558 Strain Relief



Strain
Reliefs

Glenair Connector
Designator E

MIL-DTLC-26500

MS27558-4

Basic Part No.

Dash No.

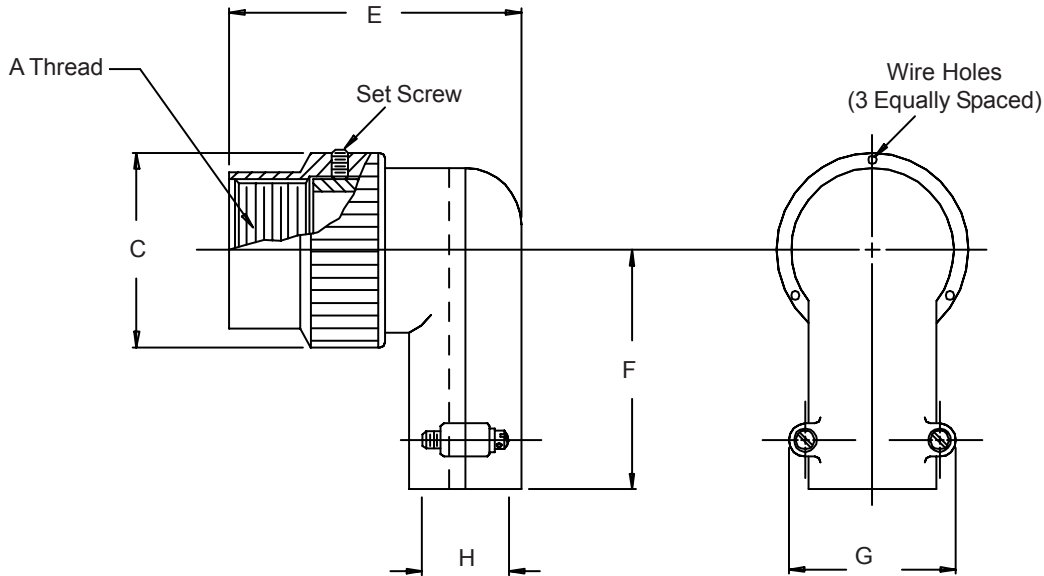

TABLE I

Dash No.	Shell Size Ref.	A Thread Class 2B	C Max	E Max	F Max	G Max	H Dia
1*	8	.437 - 28 UNEF	.672 (17.1)	1.200 (30.5)	.602 (15.3)	.892 (22.7)	.240 (6.1)
2	10	.562 - 24 UNEF	.797 (20.2)	1.320 (33.5)	.650 (16.5)	1.072 (27.2)	.365 (9.3)
3	12	.750 - 20 UNEF	1.016 (25.8)	1.320 (33.5)	.740 (18.8)	1.072 (27.2)	.365 (9.3)
4	14	.812 - 20 UNEF	1.110 (28.2)	1.487 (37.8)	.775 (19.7)	1.108 (28.1)	.515 (13.1)
5	16	.938 - 20 UNEF	1.234 (31.3)	1.470 (37.3)	.830 (21.1)	1.108 (28.1)	.515 (13.1)
6	18	1.062 - 18 UNEF	1.360 (34.5)	1.588 (40.3)	.897 (22.8)	1.233 (31.3)	.640 (16.3)
7	20	1.188 - 18 UNEF	1.485 (37.7)	1.759 (44.7)	.955 (24.3)	1.477 (37.5)	.775 (19.7)
8	22	1.312 - 18 UNEF	1.610 (40.9)	1.759 (44.7)	1.015 (25.8)	1.477 (37.5)	.775 (19.7)
9	24	1.438 - 18 UNEF	1.735 (44.1)	2.027 (51.5)	1.077 (27.4)	1.727 (43.9)	1.060 (26.9)

* Consult Factory

1. For complete dimensions see applicable Military Specification.
2. Metric dimensions (mm) are indicated in parentheses.
3. Finish: Anodize.

Glenair Connector
Designator E

MIL-DTL-26500

MS27559-4

Basic Part No. _____

Dash No. _____

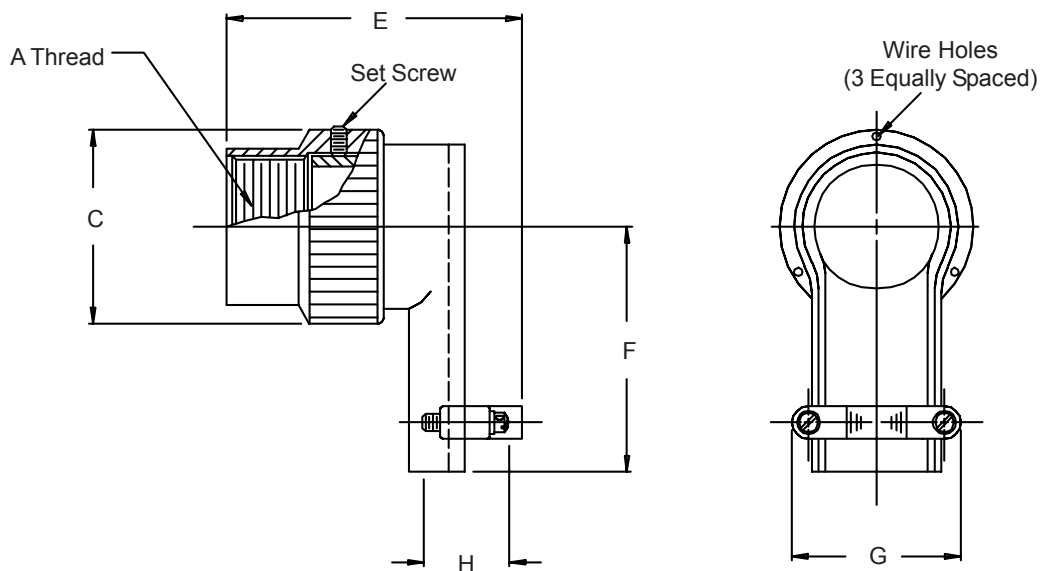

TABLE I

Dash No.	Shell Size Ref.	A Thread Class 2B	C Max	E Max	F Max	G Max	H Dia
1	8	.437 - 28 UNEF	.672 (17.1)	1.173 (29.8)	.602 (15.3)	.892 (22.7)	.201 (5.1)
2	10	.562 - 24 UNEF	.797 (20.2)	1.293 (32.8)	.650 (16.5)	1.072 (27.2)	.320 (8.1)
3	12	.750 - 20 UNEF	1.016 (25.8)	1.293 (32.8)	.740 (18.8)	1.072 (27.2)	.320 (8.1)
4	14	.812 - 20 UNEF	1.110 (28.2)	1.460 (37.1)	.775 (19.7)	1.108 (28.1)	.452 (11.5)
5	16	.938 - 20 UNEF	1.234 (31.3)	1.443 (36.7)	.830 (21.1)	1.108 (28.1)	.508 (12.9)
6	18	1.062 - 18 UNEF	1.360 (34.5)	1.561 (39.6)	.897 (22.8)	1.233 (31.3)	.571 (14.5)
7	20	1.188 - 18 UNEF	1.485 (37.7)	1.732 (44.0)	.955 (24.3)	1.477 (37.5)	.748 (19.0)
8	22	1.312 - 18 UNEF	1.610 (40.9)	1.732 (44.0)	1.015 (25.8)	1.477 (37.5)	.748 (19.0)
9	24	1.438 - 18 UNEF	1.735 (44.1)	2.000 (50.8)	1.077 (27.4)	1.727 (43.9)	.996 (25.3)

1. For complete dimensions see applicable Military Specification.
2. Metric dimensions (mm) are indicated in parentheses.
3. Finish: Anodize.

M28840/1 Strain Relief



Strain
Reliefs

Glenair Connector
Designator G

MIL-DTL-28840

M28840/1 J W

Basic Part No.

Dash No.

Material and Finish Designator

W = Aluminum, Cadmium Olive

Drab over Electroless Nickel

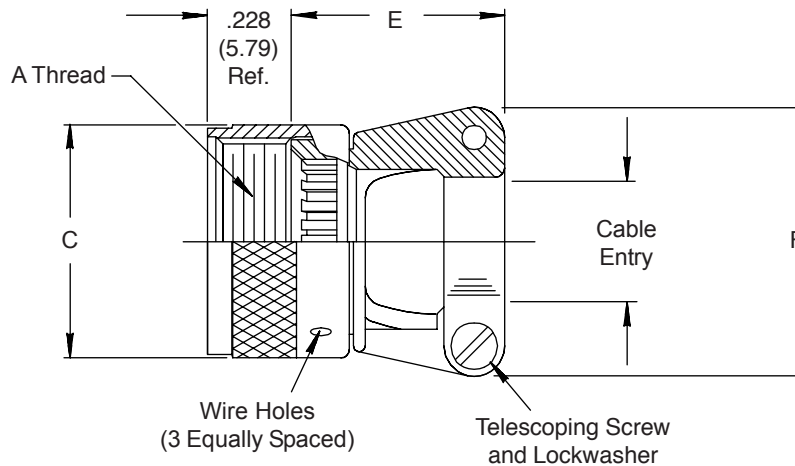

TABLE I

Designator	Shell Size Ref.	A Thread Class 2B	C Max	E Max	F Max	Cable Entry	
						Closed	Open
A	11	.750 - 20 UNEF	1.028 (26.1)	1.091 (27.7)	.903 (22.9)	.177 (4.5)	.286 (7.3)
B	13	.875 - 20 UNEF	1.141 (29.0)	1.091 (27.7)	.977 (24.8)	.177 (4.5)	.286 (7.3)
C	15	1.000 - 20 UNEF	1.263 (32.1)	1.091 (27.7)	1.151 (29.2)	.250 (6.4)	.416 (10.6)
D	17	1.125 - 18 UNEF	1.387 (35.2)	1.206 (30.6)	1.281 (32.5)	.291 (7.4)	.476 (12.1)
E	19	1.250 - 18 UNEF	1.513 (38.4)	1.320 (33.5)	1.406 (35.7)	.348 (8.8)	.626 (15.9)
F	23	1.438 - 18 UNEF	1.703 (43.3)	1.445 (36.7)	1.576 (40.0)	.429 (10.9)	.831 (21.1)
G	25	1.562 - 18 UNEF	1.825 (46.4)	1.570 (39.9)	1.666 (42.3)	.523 (13.3)	.956 (24.3)
H	29	1.875 - 16 UN	2.143 (54.4)	1.721 (43.7)	2.046 (52.0)	.643 (16.3)	1.081 (27.5)
J	33	2.062 - 16 UNS	2.329 (59.2)	1.908 (48.5)	2.209 (56.1)	.704 (17.9)	1.187 (30.1)

1. For complete dimensions see applicable Military Specification.
2. Metric dimensions (mm) are indicated in parentheses.
3. Cable Entry is defined as the accommodation entry for the wire bundle or cable. Dimensions are not intended for inspection criteria.

Glenair Connector
Designator G
MIL-C-28840
M28840/2 J W

Basic Part No.

Designator

Material and Finish Designator

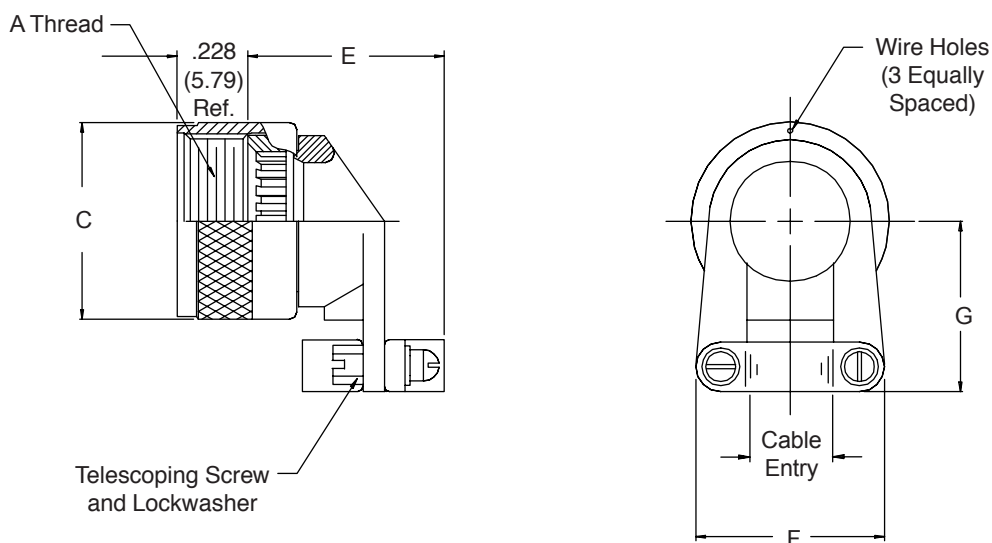
 W = Aluminum, Cadmium Olive
 Drab over Electroless Nickel

TABLE I

Desig- nator	Shell Size Ref.	A Thread Class 2B	C Max	E Max	F Max	G Max	Cable Entry		
							Min	Max	
A	11	.750 - 20 UNEF	1.028 (26.1)	1.071 (27.2)	.903 (22.9)	.929 (23.6)	.177 (4.5)	.286 (7.3)	
B	13	.875 - 20 UNEF	1.141 (29.0)	1.071 (27.2)	.977 (24.8)	.929 (23.6)	.177 (4.5)	.286 (7.3)	
C	15	1.000 - 20 UNEF	1.263 (32.1)	1.280 (32.5)	1.151 (29.2)	1.056 (26.8)	.250 (6.4)	.416 (10.6)	
D	17	1.125 - 18 UNEF	1.387 (35.2)	1.392 (35.4)	1.281 (32.5)	1.233 (31.3)	.291 (7.4)	.476 (12.1)	
E	19	1.250 - 18 UNEF	1.513 (38.4)	1.517 (38.5)	1.406 (35.7)	1.296 (32.9)	.348 (8.8)	.626 (15.9)	
F	23	1.438 - 18 UNEF	1.703 (43.3)	1.642 (41.7)	1.576 (40.0)	1.358 (34.5)	.429 (10.9)	.831 (21.1)	
G	25	1.562 - 18 UNEF	1.825 (46.4)	1.767 (44.9)	1.666 (42.3)	1.420 (36.1)	.523 (13.3)	.956 (24.3)	
H	29	1.875 - 16 UN	2.143 (54.4)	1.905 (48.4)	2.046 (52.0)	1.634 (41.5)	.643 (16.3)	1.081 (27.5)	
J	33	2.062 - 16 UNS	2.329 (59.2)	1.968 (50.0)	2.209 (56.1)	1.859 (47.2)	.704 (17.9)	1.187 (30.1)	

1. For complete dimensions see applicable Military Specification.
2. Metric dimensions (mm) are indicated in parentheses.
3. Cable Entry is defined as the accommodation entry for the wire bundle or cable.
Dimensions are not intended for inspection criteria.

M28840/3 Strain Relief



Strain
Reliefs

Glenair Connector
Designator G

MIL-C-28840

M28840/3 J W

Basic Part No.

Designator

Material and Finish Designator

W = Aluminum, Cadmium Olive

Drab over Electroless Nickel

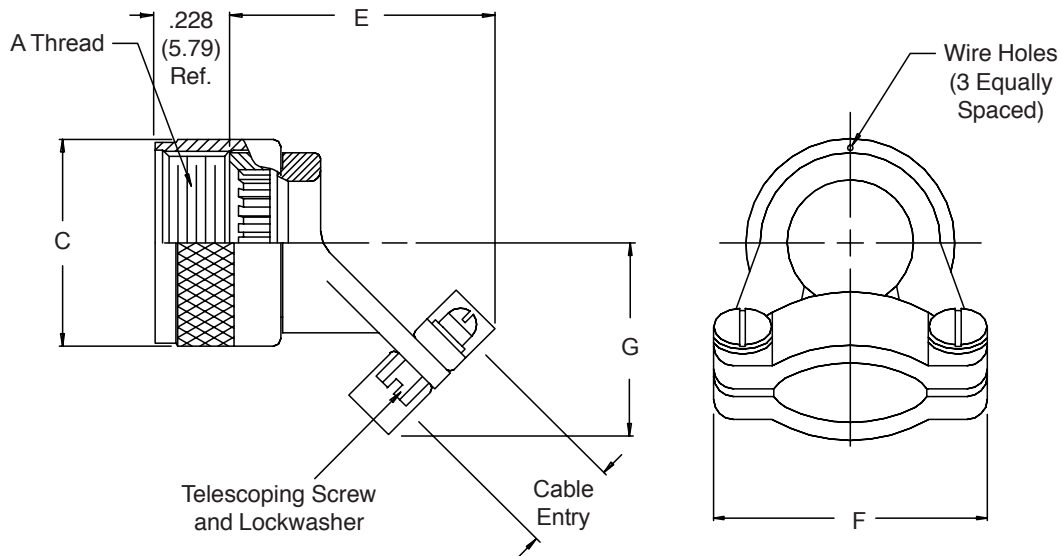

TABLE I

Designator	Shell Size Ref.	A Thread Class 2B	C Max	E Max	F Max	G Max	Cable Entry	
							Min	Max
A	11	.750 - 20 UNEF	1.028 (26.1)	1.650 (41.9)	.903 (22.9)	.929 (23.6)	.177 (4.5)	.286 (7.3)
B	13	.875 - 20 UNEF	1.141 (29.0)	1.650 (41.9)	.977 (24.8)	.929 (23.6)	.177 (4.5)	.286 (7.3)
C	15	1.000 - 20 UNEF	1.263 (32.1)	1.765 (44.8)	1.151 (29.2)	1.056 (26.8)	.250 (6.4)	.416 (10.6)
D	17	1.125 - 18 UNEF	1.387 (35.2)	1.874 (47.6)	1.281 (32.5)	1.233 (31.3)	.291 (7.4)	.476 (12.1)
E	19	1.250 - 18 UNEF	1.513 (38.4)	1.918 (48.7)	1.406 (35.7)	1.296 (32.9)	.348 (8.8)	.626 (15.9)
F	23	1.438 - 18 UNEF	1.703 (43.3)	1.962 (49.8)	1.576 (40.0)	1.358 (34.5)	.429 (10.9)	.831 (21.1)
G	25	1.562 - 18 UNEF	1.825 (46.4)	2.006 (51.0)	1.666 (42.3)	1.420 (36.1)	.523 (13.3)	.956 (24.3)
H	29	1.875 - 16 UN	2.143 (54.4)	2.301 (58.4)	2.046 (52.0)	1.634 (41.5)	.643 (16.3)	1.081 (27.5)
J	33	2.062 - 16 UNS	2.329 (59.2)	2.389 (60.7)	2.209 (56.1)	1.859 (47.2)	.704 (17.9)	1.187 (30.1)

1. For complete dimensions see applicable Military Specification.
2. Metric dimensions (mm) are indicated in parentheses.
3. Cable Entry is defined as the accommodation entry for the wire bundle or cable. Dimensions are not intended for inspection criteria.

Glenair Connector
Designator J

MIL-C-81511
Series 1, 2, 3 & 4

VG95329

M81511/13-16 A1

Basic Part No. _____ Adapter Connector Class Designator
Shell Size _____ A1 = Classes E, H and P
B1 = Classes A, B, C, F, G and T

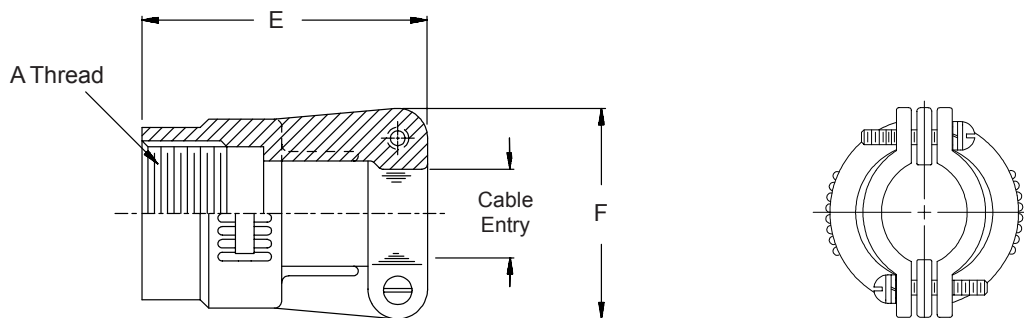

TABLE I

Shell Size	A Thread Class 2B	E Max	F Max	Cable Entry	
				Min	Max
08	.500 - 28 UNEF	1.375 (34.9)	.775 (19.7)	.062 (1.6)	.125 (3.2)
10	.625 - 28 UN	1.375 (34.9)	.955 (24.3)	.125 (3.2)	.250 (6.4)
14	.875 - 28 UN	1.375 (34.9)	1.145 (29.1)	.250 (6.4)	.500 (12.7)
16	1.000 - 28 UN	1.375 (34.9)	1.210 (30.7)	.375 (9.5)	.625 (15.9)
18	1.125 - 28 UN	1.375 (34.9)	1.330 (33.8)	.500 (12.7)	.750 (19.1)
20	1.250 - 28 UN	1.452 (36.9)	1.470 (37.3)	.625 (15.9)	.875 (22.2)
22	1.375 - 28 UN	1.452 (36.9)	1.580 (40.1)	.750 (19.1)	1.000 (25.4)
24	1.500 - 28 UN	1.452 (36.9)	1.720 (43.7)	.750 (19.1)	1.125 (28.6)

1. For complete dimensions see applicable Military Specification.
2. Metric dimensions (mm) are indicated in parentheses.
3. Cable Entry is defined as the accommodation entry for the wire bundle or cable. Dimensions are not intended for inspection criteria.

AS85049/1 and MS3057B Strain Reliefs



Strain
Reliefs

MIL-DTL-5015
MS "V" Thread
(Mates to General
Duty 'A' Endbell)

M85049/1-12B
Basic Part No. _____ Dash No. _____

SUPERCEDED SPECIFICATION

MS3057-16B
Basic Part No. _____ Dash No. _____

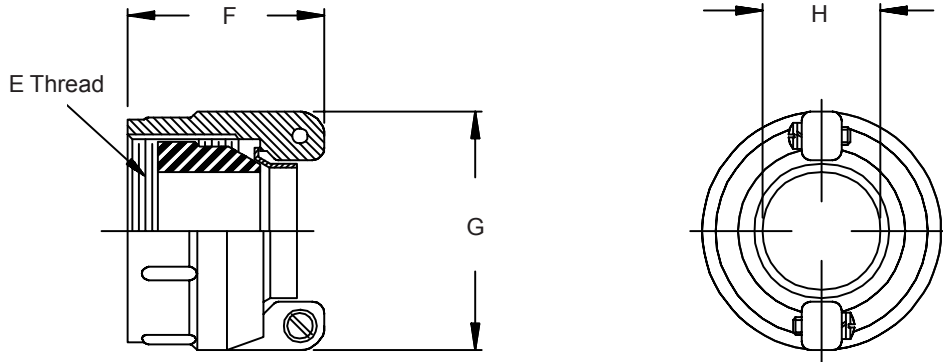

TABLE I

Dash No.	Conn. Shell Ref.(s)	E Thread Class 2B	F Max	G Dia Max	H Min
3B	8S, 10S	1/2 - 28 UNEF	1.031 (26.2)	.812 (20.6)	.231 (5.9)
4B	10SL, 12S, 12	5/8 - 24 UNEF	1.031 (26.2)	.937 (23.8)	.315 (8.0)
6B	14S, 14	3/4 - 20 UNEF	1.031 (26.2)	1.062 (27.0)	.440 (11.2)
8B	16S, 16	7/8 - 20 UNEF	1.031 (26.2)	1.188 (30.2)	.515 (13.1)
10B	18	1 - 20 UNEF	1.094 (27.8)	1.312 (33.3)	.614 (15.6)
12B	20, 22	1 3/16 - 18 UNEF	1.219 (31.0)	1.562 (39.7)	.738 (18.7)
16B	24, 28	1 7/16 - 18 UNEF	1.219 (31.0)	1.750 (44.5)	.926 (23.5)
20B	32	1 3/4 - 18 UNS	1.344 (34.1)	2.250 (57.2)	1.200 (30.5)
24B	36	2 - 18 UNS	1.547 (39.3)	2.375 (60.3)	1.363 (34.6)
28B	40	2 1/4 - 16 UN	1.547 (39.3)	2.625 (66.7)	1.611 (40.9)
32B	44	2 1/2 - 16 UN	1.734 (44.0)	2.812 (71.4)	1.865 (47.4)
40B	48	3 - 16 UN	1.781 (45.2)	3.312 (84.1)	2.365 (60.1)

1. For complete dimensions see applicable Military Specification.
2. Metric dimensions (mm) are indicated in parentheses.
3. Cable Entry is defined as the accommodation entry for the wire bundle or cable. Dimensions are not intended for inspection criteria.
4. Finish on M85049/1 is cadmium olive drab over electroless nickel (1,000 hour salt spray).

**MIL-DTL-5015
MS "V" Thread
(Mates to General
Duty 'A' Endbell)**

M85049/2-12C

Basic Part No. _____ Dash No. _____

SUPERCEDED SPECIFICATION

MS3057-16C

Basic Part No. _____ Dash No. _____

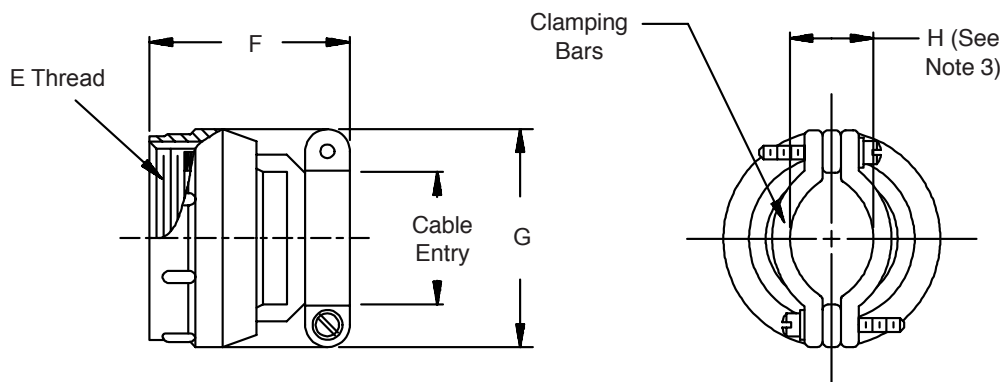

TABLE I

Dash No.	Conn. Shell Ref.(s)	E Thread Class 2B	F Max	G Dia Max	H Max Closed	Cable Entry Max
3C	8S, 10S	1/2 - 28 UNEF	1.375 (34.9)	.812 (20.6)	.217 (5.5)	.219 (5.6)
4C	10SL, 12S, 12	5/8 - 24 UNEF	1.375 (34.9)	.937 (23.8)	.296 (7.5)	.312 (7.9)
6C	14S, 14	3/4 - 20 UNEF	1.375 (34.9)	1.062 (27.0)	.390 (9.9)	.438 (11.1)
8C	16S, 16	7/8 - 20 UNEF	1.375 (34.9)	1.188 (30.2)	.434 (11.0)	.531 (13.5)
10C	18	1 - 20 UNEF	1.437 (36.5)	1.312 (33.3)	.434 (11.0)	.625 (15.9)
12C	20, 22	1 3/16 - 18 UNEF	1.437 (36.5)	1.562 (39.7)	.596 (15.1)	.750 (19.1)
16C	24, 28	1 7/16 - 18 UNEF	1.562 (39.7)	1.750 (44.5)	.596 (15.1)	.938 (23.8)
20C	32	1 3/4 - 18 UNS	1.812 (46.0)	2.250 (57.2)	.858 (21.8)	1.250 (31.8)
24C	36	2 - 18 UNS	2.062 (52.4)	2.375 (60.3)	.858 (21.8)	1.375 (34.9)
28C	40	2 1/4 - 16 UN	2.062 (52.4)	2.625 (66.7)	1.107 (28.1)	1.625 (41.3)
32C	44	2 1/2 - 16 UN	2.188 (55.6)	2.812 (71.4)	1.421 (36.1)	1.875 (47.6)

1. For complete dimensions see applicable Military Specification.
2. Metric dimensions (mm) are indicated in parentheses.
3. Cable Entry is defined as the accomodation entry for the wire bundle or cable. Dimensions are not intended for inspection criteria.
4. Finish on M85049/2 is cadmium olive drab over electroless nickel (1,000 hour salt spray).

AS85049/38 Strain Relief



Strain
Reliefs

Glenair Connector
Designator H

MIL-DTL-38999
Series III & IV,
EN3645

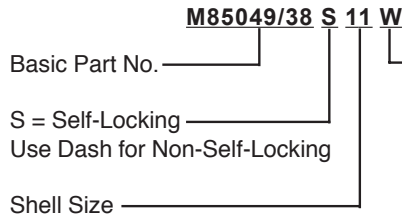

Material and Finish Designator
 A = Aluminum, Black Anodize
 (Non-Self-Locking Only)
 N = Aluminum, Electroless Nickel
 (Self-Locking Only)
 S = 300 Series Steel, Passivated
 (Self-Locking Only)
 W = Aluminum, 500 Hour Cadmium Olive Drab
 Over Electroless Nickel

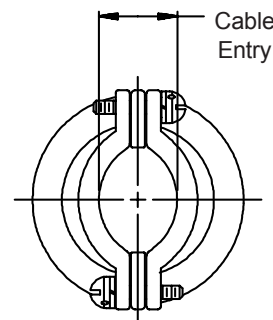
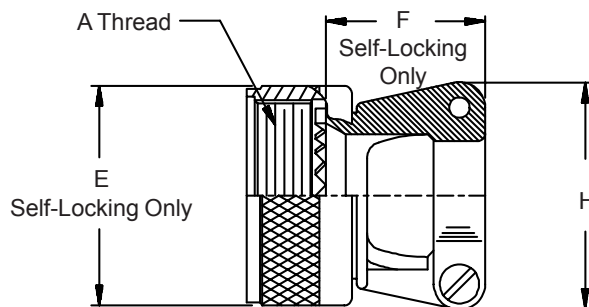

Note: Screw orientation shown is for non-self-locking configuration. Screws on self-locking configurations are on the same side/face of the clamp.

TABLE I

Shell Size	Shell Size Ref.	A Thread Class 2B	E Dia Max Self-Locking Only	F Max Self-Locking Only	H Max	Cable Entry	
						Min	Max
9	A	M12 X 1 - 6H	.858 (21.8)	.91 (23.1)	.85 (21.6)	.098 (2.5)	.234 (5.9)
11	B	M15 X 1 - 6H	.984 (25.0)	.91 (23.1)	.90 (22.9)	.153 (3.9)	.234 (5.9)
13	C	M18 X 1 - 6H	1.157 (29.4)	1.01 (25.7)	1.10 (27.9)	.190 (4.8)	.328 (8.3)
15	D	M22 X 1 - 6H	1.279 (32.5)	1.06 (26.9)	1.15 (29.2)	.260 (6.6)	.457 (11.6)
17	E	M25 X 1 - 6H	1.406 (35.7)	1.16 (29.5)	1.30 (33.0)	.283 (7.2)	.614 (15.6)
19	F	M28 X 1 - 6H	1.516 (38.5)	1.41 (35.8)	1.50 (38.1)	.325 (8.3)	.634 (16.1)
21	G	M31 X 1 - 6H	1.642 (41.7)	1.51 (38.4)	1.60 (40.6)	.343 (8.7)	.698 (17.7)
23	H	M34 X 1 - 6H	1.768 (44.9)	1.66 (42.2)	1.70 (43.2)	.381 (9.7)	.823 (20.9)
25	J	M37 X 1 - 6H	1.889 (48.0)	1.76 (44.7)	1.80 (45.7)	.418 (10.6)	.853 (21.7)

1. For complete dimensions see applicable Military Specification.
2. Metric dimensions (mm) are indicated in parentheses.
3. Cable Entry is defined as the accommodation entry for the wire bundle or cable. Dimensions are not intended for inspection criteria.

Glenair Connector
Designator HMIL-DTL-38999
Series III & IV,
EN3645

M85049/39 S 11 W

Basic Part No. _____

S = Self-Locking _____
Use Dash for Non-Self-Locking

Shell Size _____

Material and Finish Designator

A = Aluminum, Black Anodize
N = Aluminum, Electroless Nickel
S = 300 Series Steel, Passivated
W = Aluminum, 1,000 Hour Cadmium
Olive Drab Over Electroless Nickel

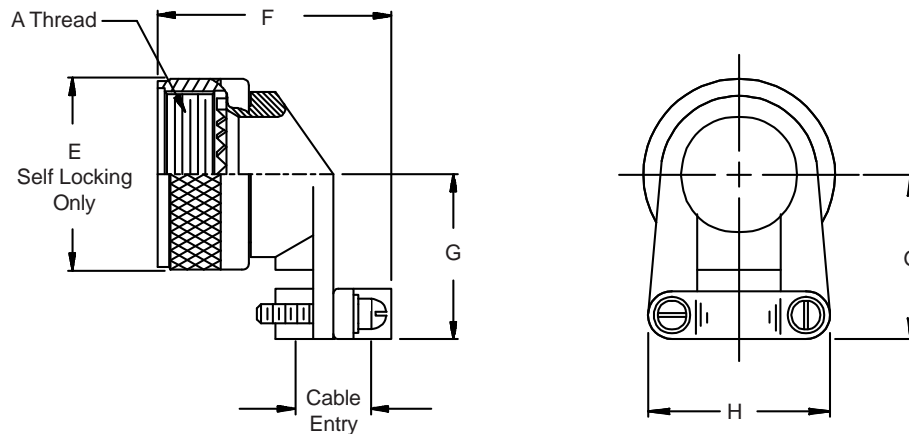

TABLE I

Shell Size	Shell Size Ref.	A Thread Class 2B	E Dia Max Self-Locking Only	F Max	G Max	H Max	Cable Entry	
							Min	Max
9	A	M12 X 1 - 6H	.858 (21.8)	1.20 (30.5)	1.00 (25.4)	.85 (21.6)	.098 (2.5)	.234 (5.9)
11	B	M15 X 1 - 6H	.984 (25.0)	1.20 (30.5)	1.10 (27.9)	.90 (22.9)	.153 (3.9)	.234 (5.9)
13	C	M18 X 1 - 6H	1.157 (29.4)	1.40 (35.6)	1.10 (27.9)	1.10 (27.9)	.190 (4.8)	.328 (8.3)
15	D	M22 X 1 - 6H	1.279 (32.5)	1.45 (36.8)	1.25 (31.8)	1.15 (29.2)	.260 (6.6)	.457 (11.6)
17	E	M25 X 1 - 6H	1.406 (35.7)	1.60 (40.6)	1.30 (33.0)	1.30 (33.0)	.283 (7.2)	.614 (15.6)
19	F	M28 X 1 - 6H	1.516 (38.5)	1.70 (43.2)	1.35 (34.3)	1.50 (38.1)	.325 (8.3)	.634 (16.1)
21	G	M31 X 1 - 6H	1.642 (41.7)	1.85 (47.0)	1.60 (40.6)	1.60 (40.6)	.343 (8.7)	.698 (17.7)
23	H	M34 X 1 - 6H	1.768 (44.9)	1.95 (49.5)	1.75 (44.5)	1.70 (43.2)	.381 (9.7)	.823 (20.9)
25	J	M37 X 1 - 6H	1.889 (48.0)	2.10 (53.3)	1.85 (47.0)	1.80 (45.7)	.418 (10.6)	.853 (21.7)

1. For complete dimensions see applicable Military Specification.
2. Metric dimensions (mm) are indicated in parentheses.
3. Cable Entry is defined as the accommodation entry for the wire bundle or cable.
Dimensions are not intended for inspection criteria.

AS85049/41 and MS3057A Strain Reliefs



Strain
Reliefs

MIL-DTL-5015
MS "V" Thread
(Mates to General
Duty 'A' Endbell)

M85049/41-3A

Basic Part No. _____ Dash No. _____

SUPERCEDED SPECIFICATION

MS3057-16A

Basic Part No. _____ Dash No. _____

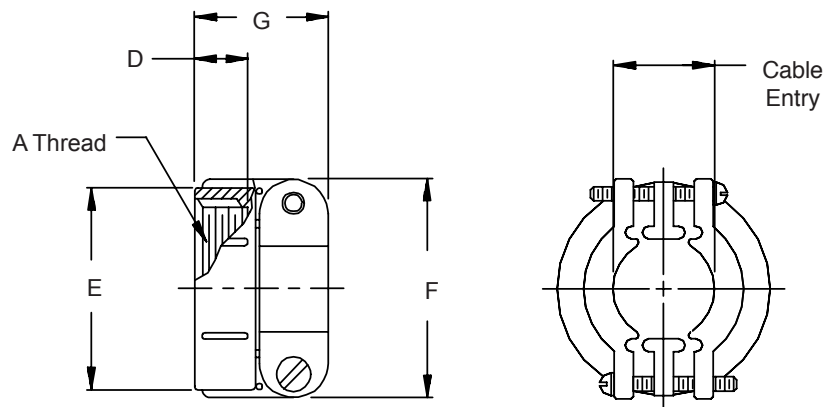

TABLE I

Dash No.	Conn. Shell Ref.(s)	A Thread Class 2B	Cable Entry Max	D Ref.	E Dia ±.031 (0.8)	F ±.031 (0.8)	G ±.031 (0.8)
3A	8S, 10S	1/2 - 28 UNEF	.250 (6.4)	.406 (10.3)	.688 (17.5)	.812 (20.6)	.812 (20.6)
4A	10SL, 12S, 12	5/8 - 24 UNEF	.312 (7.9)	.406 (10.3)	.812 (20.6)	.875 (22.2)	.812 (20.6)
6A	14S, 14	3/4 - 20 UNEF	.438 (11.1)	.406 (10.3)	.969 (24.6)	1.062 (27.0)	.875 (22.2)
8A	16S, 16	7/8 - 20 UNEF	.562 (14.3)	.406 (10.3)	1.094 (27.8)	1.156 (29.4)	.938 (23.8)
10A	18	1 - 20 UNEF	.625 (15.9)	.406 (10.3)	1.188 (30.2)	1.250 (31.8)	.938 (23.8)
12A	20, 22	1 3/16 - 18 UNEF	.750 (19.1)	.406 (10.3)	1.375 (34.9)	1.469 (37.3)	.938 (23.8)
16A	24, 28	1 7/16 - 18 UNEF	.938 (23.8)	.406 (10.3)	1.656 (42.1)	1.688 (42.9)	1.031 (26.2)
20A	32	1 3/4 - 18 UNS	1.250 (31.8)	.469 (11.9)	2.031 (51.6)	2.031 (51.6)	1.094 (27.8)
24A	36	2 - 18 UNS	1.375 (34.9)	.531 (13.5)	2.219 (56.4)	2.281 (57.9)	1.156 (29.4)
28A	40	2 1/4 - 16 UN	1.625 (41.3)	.531 (13.5)	2.500 (63.5)	2.688 (68.3)	1.688 (42.9)
32A	44	2 1/2 - 16 UN	1.875 (47.6)	.594 (15.1)	2.781 (70.6)	2.938 (74.6)	1.750 (44.5)
40A	48	3 - 16 UN	2.375 (60.3)	.656 (16.7)	3.281 (83.3)	3.500 (88.9)	1.750 (44.5)

1. For complete dimensions see applicable Military Specification.
2. Metric dimensions (mm) are indicated in parentheses.
3. Cable Entry is defined as the accommodation entry for the wire bundle or cable. Dimensions are not intended for inspection criteria.
4. Finish on M85049/41 is cadmium olive drab over electroless nickel (1,000 hour salt spray).

**MIL-DTL-5015
MS "V" Thread
(Mates to General
Duty 'A' Endbell)**

M85049/42-10D W
Basic Part No. _____
Dash No. _____

Material and Finish
N = Aluminum, Electroless Nickel
S = 300 Series Steel, Passivate
W = Aluminum, 1,000 Hour Cadmium Olive Drab
Over Electroless Nickel

MS3057-10D A
Basic Part No. _____
Dash No. _____

SUPERCEDED SPECIFICATION

Material and Finish
A = Aluminum, Cadmium Olive Drab over
Electroless Nickel
C = Aluminum, Cadmium Olive Drab
N = Aluminum, Electroless Nickel
D = 300 Series Steel, Cadmium Plate Black
S = 300 Series Steel, Passivate

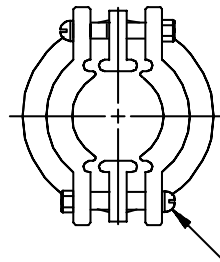
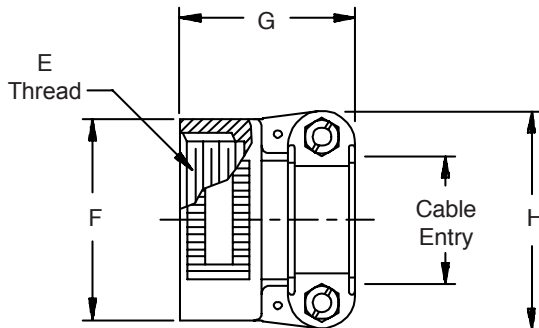

Stainless Steel
Clamp Saddle
Configuration

Telescoping Screws

TABLE I

Dash No.	E Thread Class 2B	F Dia Max	G Dia		H		Cable Entry Max
			$\pm .020$	(.5)	$\pm .020$	(.5)	
4D	5/8 - 24 UNEF	.937 (23.8)	1.281	(32.5)	.937	(23.8)	.312 (7.9)
6D	3/4 - 20 UNEF	1.031 (26.2)	1.281	(32.5)	1.125	(28.6)	.437 (11.1)
8D	7/8 - 20 UNEF	1.250 (31.8)	1.281	(32.5)	1.312	(33.3)	.562 (14.3)
10D	1 - 20 UNEF	1.250 (31.8)	1.281	(32.5)	1.312	(33.3)	.625 (15.9)
12D	1 3/16 - 18 UNEF	1.437 (36.5)	1.312	(33.3)	1.531	(38.9)	.750 (19.1)
16D	1 7/16 - 18 UNEF	1.688 (42.9)	1.406	(35.7)	1.750	(44.5)	.937 (23.8)
20D	1 3/4 - 18 UNS	2.000 (50.8)	1.563	(39.7)	2.093	(53.2)	1.250 (31.8)
24D	2 - 18 UNS	2.250 (57.2)	1.625	(41.3)	2.343	(59.5)	1.375 (34.9)
28D	2 1/4 - 16 UN	2.500 (63.5)	1.900	(48.3)	2.750	(69.9)	1.625 (41.3)
32D	2 1/2 - 16 UN	2.750 (69.9)	1.900	(48.3)	3.000	(76.2)	1.875 (47.6)

1. For complete dimensions see applicable Military Specification.
2. Metric dimensions (mm) are indicated in parentheses.
3. Cable Entry is defined as the accommodation entry for the wire bundle or cable. Dimensions are not intended for inspection criteria.

AS85049/43 Strain Relief



Strain
Reliefs

Glenair Connector Designator A

MIL-DTL-5015 Series 3400,
MIL-DTL-26482 Series 2,
AS81703 Series 3,
MIL-DTL-83723 Series I &
III, 40M39569, DEF 5326-3,
EN 2997, EN 3646,
ESC 10, ESC 11, LN 29504,
NFC93422 Series HE302,
PAN 6432-1, PAN 6432-2,
PATT 602

M85049/43-12 W

Basic Part No. _____

Dash No. _____

Material and Finish Designator

N = Aluminum, Electroless Nickel

W = Aluminum, 1,000 Hour Cadmium Olive
Drab Over Electroless Nickel

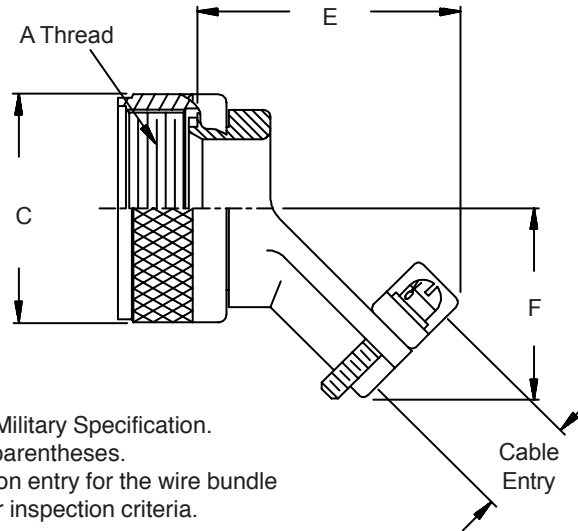

1. For complete dimensions see applicable Military Specification.
2. Metric dimensions (mm) are indicated in parentheses.
3. Cable Entry is defined as the accommodation entry for the wire bundle or cable. Dimensions are not intended for inspection criteria.

TABLE I

Dash No.	A Thread Class 2B	C Dia Max	E Max Closed	F Max	Cable Entry	
					Min	Max
3	.562 - 24 UNEF	.669 (17.0)	1.160 (29.5)	.772 (19.6)	.125 (3.2)	.204 (5.2)
8	.500 - 20 UNF	.617 (15.7)	1.160 (29.5)	.772 (19.6)	.125 (3.2)	.204 (5.2)
10	.625 - 24 UNEF	.734 (18.6)	1.204 (30.6)	.803 (20.4)	.187 (4.7)	.286 (7.3)
12	.750 - 20 UNEF	.858 (21.8)	1.278 (32.5)	.866 (22.0)	.291 (7.4)	.416 (10.6)
14	.875 - 20 UNEF	.984 (25.0)	1.320 (33.5)	.928 (23.6)	.351 (8.9)	.476 (12.1)
16	1.000 - 20 UNEF	1.112 (28.2)	1.426 (36.2)	.991 (25.2)	.501 (12.7)	.625 (15.9)
18	1.062 - 18 UNEF	1.218 (30.9)	1.544 (39.2)	1.110 (28.2)	.518 (13.2)	.706 (17.9)
20	1.188 - 18 UNEF	1.345 (34.2)	1.588 (40.3)	1.172 (29.8)	.581 (14.8)	.831 (21.1)
22	1.313 - 18 UNEF	1.468 (37.3)	1.632 (41.5)	1.235 (31.4)	.644 (16.4)	.956 (24.3)
24	1.438 - 18 UNEF	1.593 (40.5)	1.676 (42.6)	1.297 (32.9)	.706 (17.9)	1.081 (27.5)
28	1.750 - 18 UNS	1.969 (50.0)	1.801 (45.7)	1.543 (39.2)	.750 (19.1)	1.187 (30.1)
32	2.000 - 18 UNS	2.219 (56.4)	1.889 (48.0)	1.668 (42.4)	.875 (22.2)	1.250 (31.8)
36	2.250 - 16 UN	2.469 (62.7)	1.933 (49.1)	1.793 (45.5)	.938 (23.8)	1.375 (34.9)
40	2.500 - 16 UN	2.719 (69.1)	1.934 (49.1)	1.918 (48.7)	.938 (23.8)	1.500 (38.1)
44	2.750 - 16 UN	2.969 (75.4)	2.200 (55.9)	2.132 (54.2)	1.188 (30.2)	1.750 (44.5)
48	3.000 - 16 UN	3.219 (81.8)	2.288 (58.1)	2.257 (57.3)	1.312 (33.3)	1.875 (47.6)
61	1.500 - 18 UNEF	1.653 (42.0)	1.676 (42.6)	1.204 (30.6)	.706 (17.9)	1.081 (27.5)

**Glenair Connector
 Designator F**

MIL-DTL-38999 Series I & II,
 40M38277, PAN 6433-1,
 PATT 614, PATT 616,
 NFC93422 Series HE308 &
 HE309

M85049/45 W 10

Basic Part No. _____ Dash No. _____

Nut Finish _____

A = Black Anodize

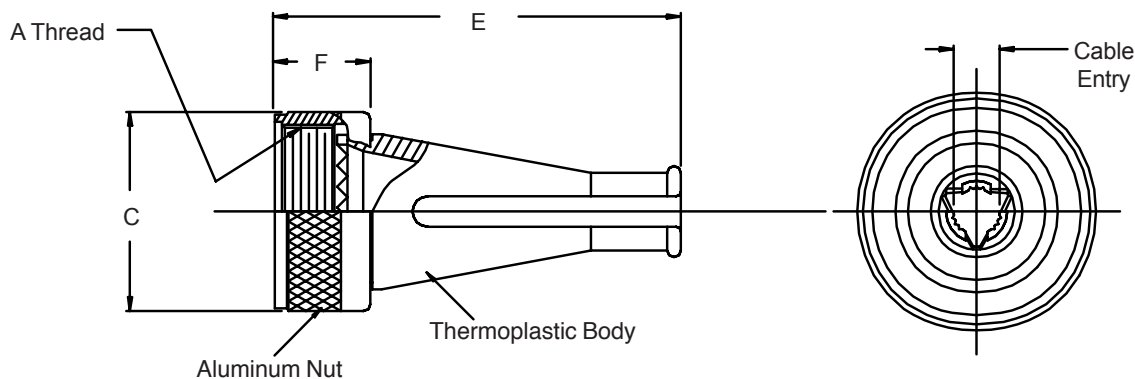
 W = 1,000 Hour Cadmium Olive Drab
 Over Electroless Nickel

TABLE I

Dash No.	Shell Size Ref.	A Thread Class 2B	C Dia Max	E Max	F Max	Cable Entry	
						Min	Max
8	8/9	.438 - 28 UNEF	.578 (14.7)	1.344 (34.1)	.422 (10.7)	.094 (2.4)	.203 (5.2)
10	10/11	.562 - 24 UNEF	.703 (17.9)	1.344 (34.1)	.422 (10.7)	.141 (3.6)	.250 (6.4)
12	12/13	.688 - 24 UNEF	.828 (21.0)	1.344 (34.1)	.422 (10.7)	.172 (4.4)	.323 (8.2)
14	14/15	.813 - 20 UNEF	.953 (24.2)	1.344 (34.1)	.422 (10.7)	.203 (5.2)	.422 (10.7)
16	16/17	.938 - 20 UNEF	1.078 (27.4)	1.344 (34.1)	.422 (10.7)	.234 (5.9)	.500 (12.7)
18	18/19	1.063 - 18 UNEF	1.203 (30.6)	1.344 (34.1)	.422 (10.7)	.265 (6.7)	.562 (14.3)
20	20/21	1.188 - 18 UNEF	1.328 (33.7)	1.422 (36.1)	.422 (10.7)	.297 (7.5)	.625 (15.9)
22	22/23	1.313 - 18 UNEF	1.453 (36.9)	1.422 (36.1)	.422 (10.7)	.328 (8.3)	.703 (17.9)
24	24/25	1.438 - 18 UNEF	1.578 (40.1)	1.422 (36.1)	.344 (8.7)	.359 (9.1)	.765 (19.4)

1. For complete dimensions see applicable Military Specification.
2. Metric dimensions (mm) are indicated in parentheses.
3. Cable Entry is defined as the accommodation entry for the wire bundle or cable. Dimensions are not intended for inspection criteria.

AS85049/46 Strain Relief



Strain
Reliefs

Glenair Connector Designator F

MIL-DTL-38999 Series I &
II, 40M38277, PAN 6433-1,
PATT 614, PATT 616,
NFC93422 Series HE308 &
HE309

M85049/46 W 10

Basic Part No. _____ Dash No. _____

Nut Finish _____
A = Black Anodize
W = 1,000 Hour Cadmium Olive Drab
Over Electroless Nickel

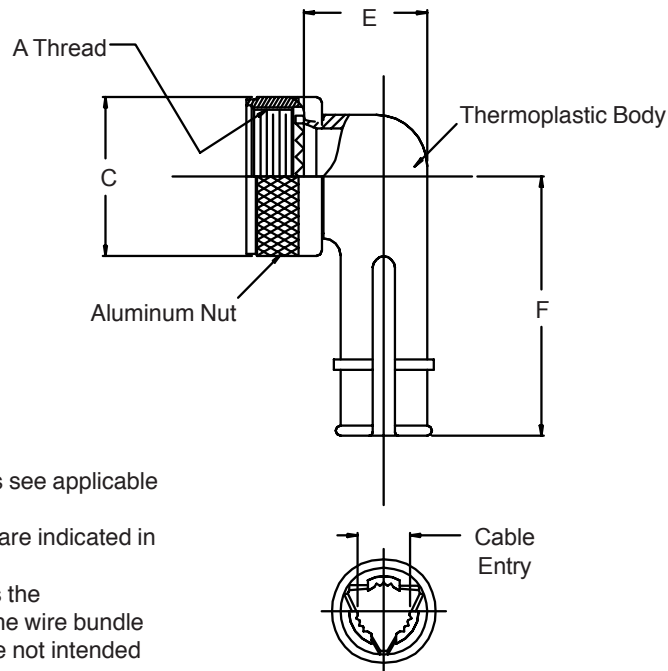

1. For complete dimensions see applicable Military Specification.
2. Metric dimensions (mm) are indicated in parentheses.
3. Cable Entry is defined as the accommodation entry for the wire bundle or cable. Dimensions are not intended for inspection criteria.

TABLE I

Dash No.	Shell Size Ref.	A Thread Class 2B	C Dia Max	E Max	F Max	Cable Entry	
						Min	Max
8	8/9	.438 - 28 UNEF	.578 (14.7)	.656 (16.7)	1.015 (25.8)	.094 (2.4)	.203 (5.2)
10	10/11	.562 - 24 UNEF	.703 (17.9)	.688 (17.5)	1.062 (27.0)	.141 (3.6)	.250 (6.4)
12	12/13	.688 - 24 UNEF	.828 (21.0)	.750 (19.1)	1.125 (28.6)	.172 (4.4)	.323 (8.2)
14	14/15	.813 - 20 UNEF	.953 (24.2)	.859 (21.8)	1.328 (33.7)	.203 (5.2)	.422 (10.7)
16	16/17	.938 - 20 UNEF	1.078 (27.4)	.937 (23.8)	1.392 (35.4)	.234 (5.9)	.500 (12.7)
18	18/19	1.063 - 18 UNEF	1.203 (30.6)	1.000 (25.4)	1.453 (36.9)	.265 (6.7)	.562 (14.3)
20	20/21	1.188 - 18 UNEF	1.328 (33.7)	1.062 (27.0)	1.609 (40.9)	.297 (7.5)	.625 (15.9)
22	22/23	1.313 - 18 UNEF	1.453 (36.9)	1.141 (29.0)	1.656 (42.1)	.328 (8.3)	.703 (17.9)
24	24/25	1.438 - 18 UNEF	1.578 (40.1)	1.203 (30.6)	1.719 (43.7)	.359 (9.1)	.765 (19.4)

**Glenair Connector
Designator F**

MIL-DTL-38999 Series I & II,
40M38277, PAN 6433-1, PATT
614, PATT 616,
NFC93422 Series HE308 &
HE309

M85049/47 S W 10

Basic Part No. ———— Dash No.
Material and Finish Designator
S = Self-Locking ———— N = Aluminum, Electroless Nickel
Omit for Non-Self-Locking S = 300 Series Steel, Passivated
W = Aluminum, 1,000 Hour Cadmium Olive
Drab Over Electroless Nickel

MS27507 B-10
SUPERCEDED SPEC.

Basic Part No. ———— Dash No.
(Non-Self-Locking)
Material and Finish Designator
B = Aluminum, 500 Hour Cadmium Olive
Drab Over Electroless Nickel
F = Aluminum, Electroless Nickel

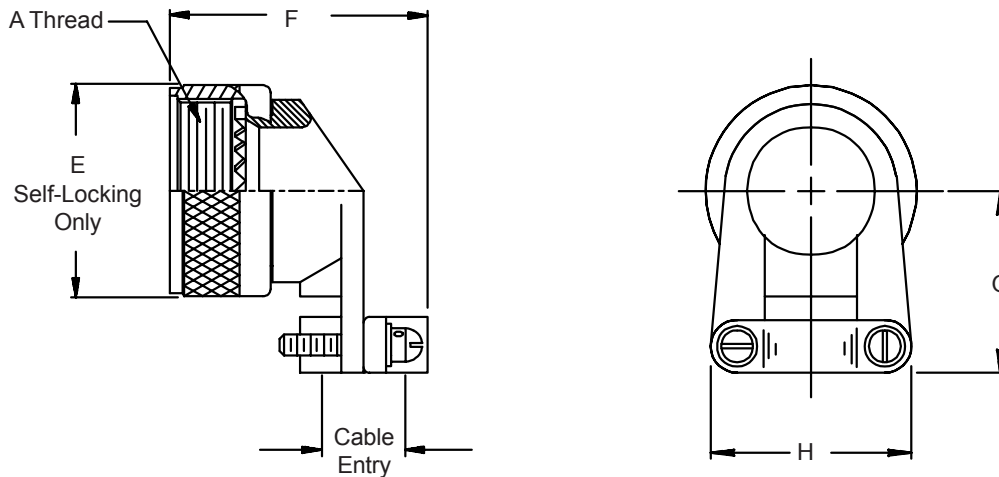
TABLE I

Dash No.	Shell Size Ref.	A Thread Class 2B	E Dia Max	F Max	G Max	H Max	Cable Entry	
							Min	Max
8	8/9	.438 - 28 UNEF	.86 (21.8)	1.38 (35.1)	1.00 (25.4)	.85 (21.6)	.098 (2.5)	.234 (5.9)
10	10/11	.562 - 24 UNEF	.98 (24.9)	1.38 (35.1)	1.10 (27.9)	.90 (22.9)	.153 (3.9)	.234 (5.9)
12	12/13	.688 - 24 UNEF	1.16 (29.5)	1.46 (37.1)	1.10 (27.9)	1.10 (27.9)	.190 (4.8)	.328 (8.3)
14	14/15	.813 - 20 UNEF	1.28 (32.5)	1.63 (41.4)	1.25 (31.8)	1.15 (29.2)	.260 (6.6)	.457 (11.6)
16	16/17	.938 - 20 UNEF	1.41 (35.8)	1.80 (45.7)	1.30 (33.0)	1.30 (33.0)	.283 (7.2)	.614 (15.6)
18	18/19	1.063 - 18 UNEF	1.52 (38.6)	1.82 (46.2)	1.35 (34.3)	1.50 (38.1)	.325 (8.3)	.634 (16.1)
20	20/21	1.188 - 18 UNEF	1.64 (41.7)	1.90 (48.3)	1.60 (40.6)	1.60 (40.6)	.343 (8.7)	.698 (17.7)
22	22/23	1.313 - 18 UNEF	1.77 (45.0)	2.04 (51.8)	1.75 (44.5)	1.70 (43.2)	.381 (9.7)	.823 (20.9)
24	24/25	1.438 - 18 UNEF	1.89 (48.0)	2.15 (54.6)	1.85 (47.0)	1.80 (45.7)	.418 (10.6)	.853 (21.7)

1. For complete dimensions see applicable Military Specification.
2. Metric dimensions (mm) are indicated in parentheses.
3. Cable Entry is defined as the accommodation entry for the wire bundle or cable. Dimensions are not intended for inspection criteria.

AS85049/49 and MS27506 Strain Reliefs



Strain
Reliefs

M85049/49-2 S 10 W

Glenair Connector Designator F

MIL-DTL-38999 Series I & II, 40M38277, PAN 6433-1, PATT 614, PATT 616, NFC93422 Series HE308 & HE309

Basic Part No. ————

S = Self-Locking
Use Dash for Non-Self-Locking

Shell Size ————

Material and Finish Designator
A = Aluminum, Black Anodize (Non-Self-Locking Only)
N = Aluminum, Electroless Nickel
S = 300 Series Steel, Passivated (Self-Locking Only)
W = Aluminum, 1,000 Hr. Cadmium Olive Drab Over Electroless Nickel

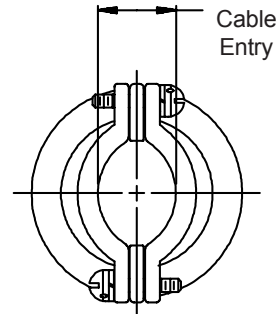
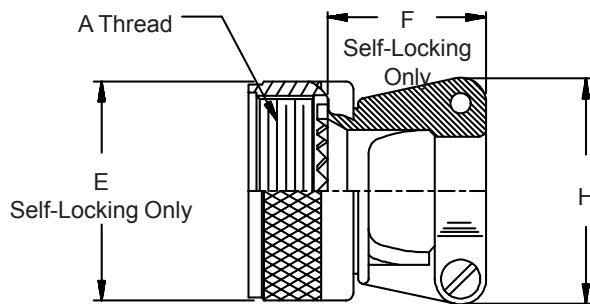

Note: Screw orientation shown is for non-self-locking configuration. Screws on self-locking configurations are on the same side/face of the clamp.

TABLE I

Dash No.	Shell Size Ref.	A Thread Class 2B	E Dia Max		H Max	Cable Entry	
			Self-Locking Only	F Max Self-Locking Only		Min	Max
8	8/9	.438 - 28 UNEF	.86 (21.8)	.91 (23.1)	.85 (21.6)	.098 (2.5)	.234 (5.9)
10	10/11	.562 - 24 UNEF	.98 (24.9)	.91 (23.1)	.90 (22.9)	.153 (3.9)	.234 (5.9)
12	12/13	.688 - 24 UNEF	1.16 (29.5)	1.01 (25.7)	1.10 (27.9)	.190 (4.8)	.328 (8.3)
14	14/15	.813 - 20 UNEF	1.28 (32.5)	1.06 (26.9)	1.15 (29.2)	.260 (6.6)	.457 (11.6)
16	16/17	.938 - 20 UNEF	1.41 (35.8)	1.16 (29.5)	1.30 (33.0)	.283 (7.2)	.634 (16.1)
18	18/19	1.063 - 18 UNEF	1.52 (38.6)	1.41 (35.8)	1.50 (38.1)	.325 (8.3)	.614 (15.6)
20	20/21	1.188 - 18 UNEF	1.64 (41.7)	1.51 (38.4)	1.60 (40.6)	.343 (8.7)	.698 (17.7)
22	22/23	1.313 - 18 UNEF	1.77 (45.0)	1.66 (42.2)	1.70 (43.2)	.381 (9.7)	.823 (20.9)
24	24/25	1.438 - 18 UNEF	1.89 (48.0)	1.76 (44.7)	1.80 (45.7)	.418 (10.6)	.853 (21.7)

1. For complete dimensions see applicable Military Specification.
2. Metric dimensions (mm) are indicated in parentheses.
3. Cable Entry is defined as the accommodation entry for the wire bundle or cable. Dimensions are not intended for inspection criteria.



AS85049/51, MS3418, and M83723/15A Strain Reliefs

Glenair Connector Designator A

MIL-DTL-5015 Series 3400,
MIL-DTL-26482 Series 2,
AS81703 Series 3,
MIL-DTL-83723 Series I &
III, 40M39569, DEF 5326-3,
EN 2997, EN 3646,
ESC 10, ESC 11, LN 29504,
NFC93422 Series HE302,
PAN 6432-1, PAN 6432-2,
PATT 602

M85049/51 S 10 W

Basic Part No. _____
S = Self-Locking
-1- = Non-Self-Locking
Dash No. _____

Material and Finish Designator
A = Aluminum, Black Anodize
N = Aluminum, Electroless Nickel
W = Aluminum, 1,000 Hour Cadmium
Olive Drab Over Electroless
Nickel

MS3418-10 C

Basic Part No. _____
(Non-Self-Locking Only)
Dash No. _____

SUPERCEDED SPEC.

Material and Finish Designator
A = Alum., 1,000 Hour Cadmium Olive
Drab Over Electroless Nickel
C = Aluminum, Cadmium Olive Drab
G = Aluminum, Black Anodize
N = Aluminum, Electroless Nickel

M83723/15A-10 A

Basic Part No. _____
(Non-Self-Locking Only)
Dash No. _____

SUPERCEDED SPEC.

Finish Designator
A = Non-Conductive, Black Anodize
R = Conductive, Electroless Nickel

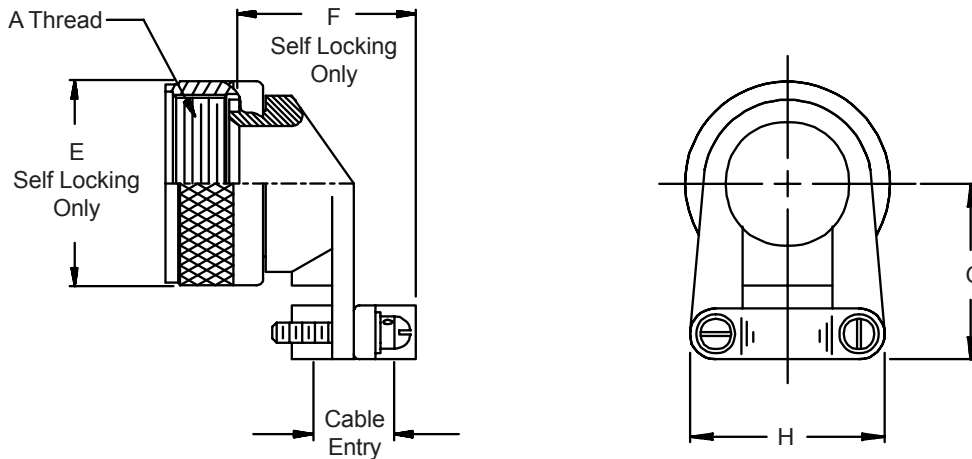

AS85049/51, MS3418, and M83723/15A
Strain Reliefs



Strain
Reliefs

TABLE I

Dash No.	A Thread Class 2B	E Dia Max Self-Locking	F Max Self-Locking	G		H		Cable Entry					
				±.062	(1.6)	±.020	(.5)	Min	Max				
3**	.562 - 24 UNEF	n/a	n/a	.777	(19.7)	.732	(18.6)	.125	(3.2)	.204	(5.2)		
8	.500 - 20 UNF	.885	(22.5)	1.257	(31.9)	.746	(18.9)	.732	(18.6)	.125	(3.2)	.204	(5.2)
10	.625 - 24 UNEF	1.010	(25.7)	1.339	(34.0)	.805	(20.4)	.812	(20.6)	.187	(4.7)	.286	(7.3)
12	.750 - 20 UNEF	1.135	(28.8)	1.532	(38.9)	.867	(22.0)	.968	(24.6)	.291	(7.4)	.416	(10.6)
14	.875 - 20 UNEF	1.260	(32.0)	1.592	(40.4)	.930	(23.6)	1.026	(26.1)	.351	(8.9)	.476	(12.1)
16	1.000 - 20 UNEF	1.385	(35.2)	1.741	(44.2)	.994	(25.2)	1.299	(33.0)	.501	(12.7)	.626	(15.9)
18	1.062 - 18 UNEF	1.510	(38.4)	1.853	(47.1)	1.171	(29.7)	1.431	(36.3)	.518	(13.2)	.706	(17.9)
20	1.188 - 18 UNEF	1.635	(41.5)	1.978	(50.2)	1.234	(31.2)	1.537	(39.0)	.581	(14.8)	.831	(21.1)
22	1.313 - 18 UNEF	1.760	(44.7)	2.108	(53.5)	1.296	(32.9)	1.633	(41.5)	.644	(16.4)	.956	(24.3)
24	1.438 - 18 UNEF	1.885	(47.9)	2.228	(56.6)	1.358	(34.5)	1.755	(44.6)	.706	(17.9)	1.081	(27.5)
28*	1.750 - 18 UNS	2.135	(54.2)	2.528	(64.2)	1.572	(39.9)	2.000	(50.8)	.750	(19.1)	1.187	(30.1)
32*	2.000 - 18 UNS	2.395	(60.8)	2.591	(65.8)	1.797	(45.6)	2.366	(60.1)	.875	(22.2)	1.250	(31.8)
36*	2.250 - 16 UN	2.635	(66.9)	2.716	(69.0)	1.922	(48.8)	2.476	(62.9)	.938	(23.8)	1.375	(34.9)
40*	2.500 - 16 UN	2.885	(73.3)	2.841	(72.2)	2.047	(52.0)	2.546	(64.7)	.938	(23.8)	1.500	(38.1)
44*	2.750 - 16 UN	3.135	(79.6)	3.091	(78.5)	2.296	(58.3)	2.840	(72.1)	1.188	(30.2)	1.750	(44.5)
48*	3.000 - 16 UN	3.385	(86.0)	3.210	(81.5)	2.421	(61.5)	3.324	(84.4)	1.312	(33.3)	1.875	(47.6)
61**	1.500 - 18 UNEF	n/a	n/a	1.388	(35.3)	1.755	(44.6)	.706	(17.9)	1.081	(27.5)		

* Not Available in Self Locking

** Not Available under M83723/15A

1. For complete dimensions see applicable Military Specification.
2. Metric dimensions (mm) are indicated in parentheses.
3. Cable Entry is defined as the accomodation entry for the wire bundle or cable. Dimensions are not intended for inspection criteria.



AS85049/52, MS3417, and M83723/15S
Strain Reliefs

Glenair Connector
Designator A

MIL-DTL-5015 Series 3400,
MIL-DTL-26482 Series 2,
AS81703 Series 3,
MIL-DTL-83723 Series I &
III, 40M39569, DEF 5326-3,
EN 2997, EN 3646,
ESC 10, ESC 11, LN 29504,
NFC93422 Series HE302,
PAN 6432-1, PAN 6432-2,
PATT 602

M85049/52 S 10 W

Basic Part No.

S = Self-Locking
-1- = Non-Self-Locking

Dash No.

Material and Finish Designator
A = Aluminum, Black Anodize
N = Aluminum, Electroless Nickel
W = Aluminum, 1,000 Hour Cadmium
Olive Drab Over Electroless
Nickel

MS3417-10 A

Basic Part No.
(Non-Self-Locking Only)

Dash No.

SUPERCEDED SPEC.

Material and Finish Designator
A = Aluminum, 1,000 Hour Cad. Olive
Drab Over Electroless Nickel
C = Aluminum, Cadmium Olive Drab
G = Aluminum, Black Anodize
N = Aluminum, Electroless Nickel

M83723/15S-10 A

Basic Part No.
(Non-Self-Locking Only)

Dash No.

SUPERCEDED SPEC.

Finish Designator
A = Non-Conductive, Black Anodize
R = Conductive, Electroless Nickel

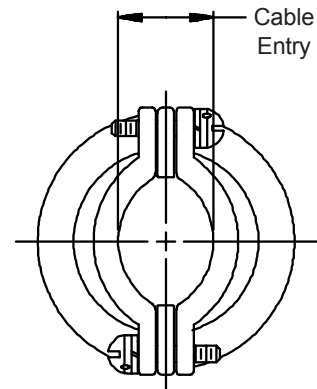
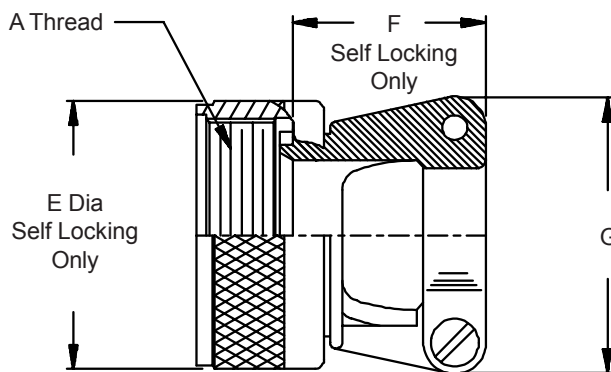

AS85049/52, MS3417, and M83723/15S
Strain Reliefs



Strain
Reliefs

TABLE I

Dash No.	A Thread Class 2B	E Dia Max Self-Locking	F Max Self-Locking	G ±.020 (.5)	Cable Entry	
					Min	Max
3**	.562 - 24 UNEF	n/a	n/a	.732 (18.6)	.125 (3.2)	.204 (5.2)
8	.500 - 20 UNF	.885 (22.5)	.73 (18.5)	.732 (18.6)	.125 (3.2)	.204 (5.2)
10	.625 - 24 UNEF	1.010 (25.7)	.85 (21.6)	.812 (20.6)	.187 (4.7)	.286 (7.3)
12	.750 - 20 UNEF	1.135 (28.8)	.98 (24.9)	.968 (24.6)	.291 (7.4)	.416 (10.6)
14	.875 - 20 UNEF	1.260 (32.0)	.98 (24.9)	1.026 (26.1)	.351 (8.9)	.476 (12.1)
16	1.000 - 20 UNEF	1.385 (35.2)	1.10 (27.9)	1.299 (33.0)	.501 (12.7)	.626 (15.9)
18	1.062 - 18 UNEF	1.510 (38.4)	1.35 (34.3)	1.431 (36.3)	.518 (13.2)	.706 (17.9)
20	1.188 - 18 UNEF	1.635 (41.5)	1.48 (37.6)	1.537 (39.0)	.581 (14.8)	.831 (21.1)
22	1.313 - 18 UNEF	1.760 (44.7)	1.60 (40.6)	1.633 (41.5)	.644 (16.4)	.956 (24.3)
24	1.438 - 18 UNEF	1.885 (47.9)	1.73 (43.9)	1.755 (44.6)	.706 (17.9)	1.081 (27.5)
28*	1.750 - 18 UNS	2.135 (54.2)	1.88 (47.8)	2.000 (50.8)	.750 (19.1)	1.187 (30.1)
32*	2.000 - 18 UNS	2.395 (60.8)	2.13 (54.1)	2.366 (60.1)	.875 (22.2)	1.250 (31.8)
36*	2.250 - 16 UN	2.635 (66.9)	2.44 (62.0)	2.476 (62.9)	.938 (23.8)	1.375 (34.9)
40*	2.500 - 16 UN	2.885 (73.3)	2.63 (66.8)	2.546 (64.7)	.938 (23.8)	1.500 (38.1)
44*	2.750 - 16 UN	3.135 (79.6)	3.00 (76.2)	2.840 (72.1)	1.188 (30.2)	1.750 (44.5)
48*	3.000 - 16 UN	3.385 (86.0)	3.40 (86.4)	3.324 (84.4)	1.312 (33.3)	1.875 (47.6)
61**	1.500 - 18 UNEF	n/a	n/a	1.755 (44.6)	.706 (17.9)	1.081 (27.5)

* Not Available in Self Locking
 * Not Available under M83723/15S

1. For complete dimensions see applicable Military Specification.
2. Metric dimensions (mm) are indicated in parentheses.
3. Cable Entry is defined as the accommodation entry for the wire bundle or cable. Dimensions are not intended for inspection criteria.

**Glenair Connector
Designator H**
**MIL-DTL-38999
Series III & IV,
EN3645**
M85049/91-11 T

Basic Part No.

M85049/91 = Straight

M85049/92 = 90°

Shell Size

Material and Finish Designator (Note 4)

 J = Composite (Conductive), Cadmium Olive Drab
Over Electroless Nickel

M = Composite (Conductive), Electroless Nickel

T = Composite (Non-Conductive) Without Plating

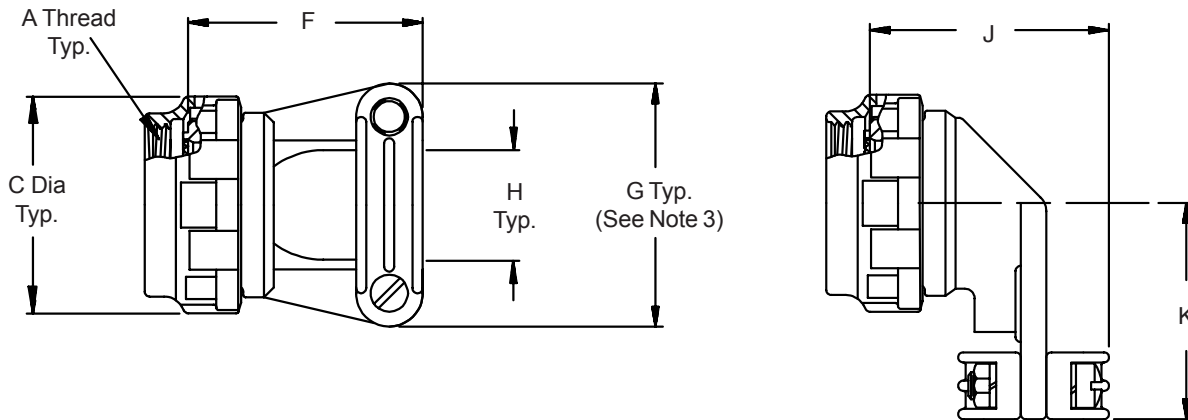
TABLE I

Shell Size	A Thread Class 2B	C Dia Max	F Max	G Max	H ±.031 Dia	J Max	K ±.062 (1.6)
09	M12 X 1 - 6H	.858 (21.8)	.840 (21.3)	.98 (24.9)	.219 (5.6)	1.06 (26.9)	.875 (22.2)
11	M15 X 1 - 6H	.984 (25.0)	.960 (24.4)	1.05 (26.7)	.264 (6.7)	1.10 (27.9)	.937 (23.8)
13	M18 X 1 - 6H	1.157 (29.4)	1.100 (27.9)	1.20 (30.5)	.344 (8.7)	1.18 (30.0)	1.031 (26.2)
15	M22 X 1 - 6H	1.280 (32.5)	1.100 (27.9)	1.30 (33.0)	.460 (11.7)	1.30 (33.0)	1.125 (28.6)
17	M25 X 1 - 6H	1.406 (35.7)	1.230 (31.2)	1.42 (36.1)	.545 (13.8)	1.38 (35.1)	1.312 (33.3)
19	M28 X 1 - 6H	1.516 (38.5)	1.410 (35.8)	1.52 (38.6)	.615 (15.6)	1.45 (36.8)	1.375 (34.9)
21	M31 X 1 - 6H	1.642 (41.7)	1.510 (38.4)	1.64 (41.7)	.698 (17.7)	1.54 (39.1)	1.500 (38.1)
23	M34 X 1 - 6H	1.768 (44.9)	1.660 (42.2)	1.77 (45.0)	.700 (17.8)	1.62 (41.1)	1.625 (41.3)
25	M37 X 1 - 6H	1.890 (48.0)	1.760 (44.7)	1.89 (48.0)	.850 (21.6)	1.69 (42.9)	1.750 (44.5)

1. For complete dimensions see applicable Military Specification.
2. Metric dimensions (mm) are indicated in parentheses.
3. Clamp Entry is measured with Saddle bars closed and seated on Clamp Ears.

Dummy Stowage Receptacles



Dummy
Stowage
Receptacles

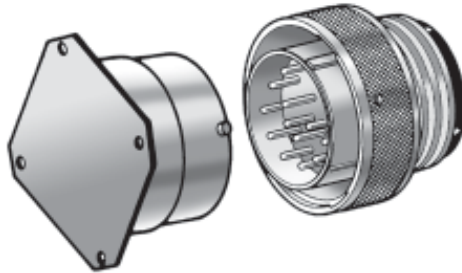

A choice of dummy stowage receptacles is offered for most circular bayonet coupled and threaded coupled connectors.

Military Specification	Superceding Part Number	Glenair's Commercial Catalog P/N	Connector Interface	Page Number
MS3105		GS3105	MIL-DTL-5015	65-2
MS3115		650DS001	MIL-DTL-26482	65-3
MS27296	M83723/61-1	650ES001	MIL-DTL-26500 Threaded and MIL-DTL-83723 Series III, Threaded	65-11
MS27297	M83723/61-2	650ES002	MIL-DTL-26500 Bayonet and MIL-DTL-83723 Series III, Bayonet	65-11
M28840/7		650GS001	MIL-C-28840	65-4
M38999/9		650FS001	MIL-DTL-38999 Series I	65-5
M38999/10		650FS002	MIL-DTL-38999 Series II	65-6
D38999/22		650HS010	MIL-DTL-38999 Series III	65-7
D38999/50		650HS007	MIL-DTL-38999 Series IV	65-8
M81511/19		650JS002	MIL-C-81511 Series 2	65-9
M81511/30		650JS001	MIL-C-81511 Series 1	65-10
M83723/45	MS3115	650DS001	MIL-DTL-26482	65-3*
M83723/61-1		650ES001	MIL-DTL-26500 Threaded and MIL-DTL-83723 Series III, Threaded	65-11
M83723/61-2		650ES002	MIL-DTL-26500 Bayonet and MIL-DTL-83723 Series III, Bayonet	65-11

* Page Number of Superceding Part Number

MS3105 Dummy Storage Receptacle

Mating Connector
MIL-DTL-5015

MS3105-16

Basic Part No. _____
Dash No. _____

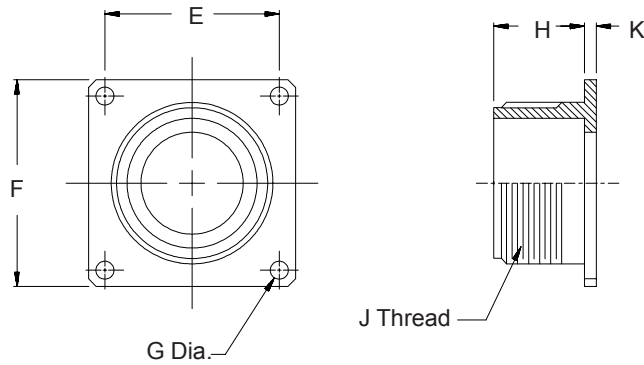

TABLE I

Shell Size	E ±.005 (.1)	F Max	G Max	H Max	J Thread Class 2A	K Max
8S	.594 (15.1)	.906 (23.0)	.130 (3.3)	.593 (15.1)	1/2 -28 UNEF	.156 (4.0)
10S	.719 (18.3)	1.031 (26.2)	.130 (3.3)	.593 (15.1)	5/8 -24 UNEF	.156 (4.0)
12S	.812 (20.6)	1.125 (28.6)	.130 (3.3)	.593 (15.1)	3/4 -20 UNEF	.156 (4.0)
12	.812 (20.6)	1.125 (28.6)	.130 (3.3)	.781 (19.8)	3/4 -20 UNEF	.156 (4.0)
14S	.906 (23.0)	1.219 (31.0)	.130 (3.3)	.593 (15.1)	7/8 -20 UNEF	.156 (4.0)
14	.906 (23.0)	1.219 (31.0)	.130 (3.3)	.781 (19.8)	7/8 -20 UNEF	.156 (4.0)
16S	.969 (24.6)	1.312 (33.3)	.130 (3.3)	.593 (15.1)	1 -20 UNEF	.156 (4.0)
16	.969 (24.6)	1.312 (33.3)	.130 (3.3)	.781 (19.8)	1 -20 UNEF	.156 (4.0)
18	1.062 (27.0)	1.406 (35.7)	.130 (3.3)	.781 (19.8)	1 1/8 -18 UNEF	.203 (5.2)
20	1.156 (29.4)	1.531 (38.9)	.130 (3.3)	.781 (19.8)	1 1/4 -18 UNEF	.203 (5.2)
22	1.250 (31.8)	1.656 (42.1)	.130 (3.3)	.781 (19.8)	1 3/8 -18 UNEF	.203 (5.2)
24	1.375 (34.9)	1.781 (45.2)	.157 (4.0)	.843 (21.4)	1 1/2 -18 UNEF	.203 (5.2)
28	1.562 (39.7)	2.031 (51.6)	.157 (4.0)	.843 (21.4)	1 3/4 -18 UNS	.203 (5.2)
32	1.750 (44.5)	2.281 (57.9)	.183 (4.6)	.906 (23.0)	2 -18 UNS	.359 (9.1)
36	1.938 (49.2)	2.531 (64.3)	.183 (4.6)	.906 (23.0)	2 1/4 -16 UN	.359 (9.1)
40	2.188 (55.6)	2.781 (70.6)	.183 (4.6)	.906 (23.0)	2 1/2 -16 UN	.359 (9.1)
44	2.375 (60.3)	3.031 (77.0)	.183 (4.6)	.906 (23.0)	2 3/4 -16 UN	.359 (9.1)
48	2.625 (66.7)	3.281 (83.3)	.183 (4.6)	.906 (23.0)	3 -16 UN	.359 (9.1)

1. For complete dimensions see applicable Military Specification.
2. Metric dimensions (mm) are indicated in parentheses.

MS3105 Dummy Storage Receptacle

Mating Connector
MIL-DTL-5015

MS3105-16

Basic Part No. _____
Dash No. _____

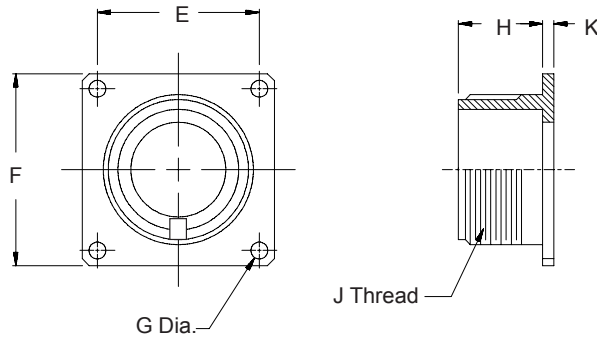

TABLE I

Shell Size	E ±.005 (.1)	F Max	G Max	H Max	J Thread Class 2A	K Max
8S	.594 (15.1)	.906 (23.0)	.130 (3.3)	.593 (15.1)	1/2 -28 UNEF	.156 (4.0)
10S	.719 (18.3)	1.031 (26.2)	.130 (3.3)	.593 (15.1)	5/8 -24 UNEF	.156 (4.0)
12S	.812 (20.6)	1.125 (28.6)	.130 (3.3)	.593 (15.1)	3/4 -20 UNEF	.156 (4.0)
12	.812 (20.6)	1.125 (28.6)	.130 (3.3)	.781 (19.8)	3/4 -20 UNEF	.156 (4.0)
14S	.906 (23.0)	1.219 (31.0)	.130 (3.3)	.593 (15.1)	7/8 -20 UNEF	.156 (4.0)
14	.906 (23.0)	1.219 (31.0)	.130 (3.3)	.781 (19.8)	7/8 -20 UNEF	.156 (4.0)
16S	.969 (24.6)	1.312 (33.3)	.130 (3.3)	.593 (15.1)	1 -20 UNEF	.156 (4.0)
16	.969 (24.6)	1.312 (33.3)	.130 (3.3)	.781 (19.8)	1 -20 UNEF	.156 (4.0)
18	1.062 (27.0)	1.406 (35.7)	.130 (3.3)	.781 (19.8)	1 1/8 -18 UNEF	.203 (5.2)
20	1.156 (29.4)	1.531 (38.9)	.130 (3.3)	.781 (19.8)	1 1/4 -18 UNEF	.203 (5.2)
22	1.250 (31.8)	1.656 (42.1)	.130 (3.3)	.781 (19.8)	1 3/8 -18 UNEF	.203 (5.2)
24	1.375 (34.9)	1.781 (45.2)	.157 (4.0)	.843 (21.4)	1 1/2 -18 UNEF	.203 (5.2)
28	1.562 (39.7)	2.031 (51.6)	.157 (4.0)	.843 (21.4)	1 3/4 -18 UNS	.203 (5.2)
32	1.750 (44.5)	2.281 (57.9)	.183 (4.6)	.906 (23.0)	2 -18 UNS	.359 (9.1)
36	1.938 (49.2)	2.531 (64.3)	.183 (4.6)	.906 (23.0)	2 1/4 -16 UN	.359 (9.1)
40	2.188 (55.6)	2.781 (70.6)	.183 (4.6)	.906 (23.0)	2 1/2 -16 UN	.359 (9.1)
44	2.375 (60.3)	3.031 (77.0)	.183 (4.6)	.906 (23.0)	2 3/4 -16 UN	.359 (9.1)
48	2.625 (66.7)	3.281 (83.3)	.183 (4.6)	.906 (23.0)	3 -16 UN	.359 (9.1)

1. For complete dimensions see applicable Military Specification.
2. Metric dimensions (mm) are indicated in parentheses.

Mating Connector
MIL-C-28840

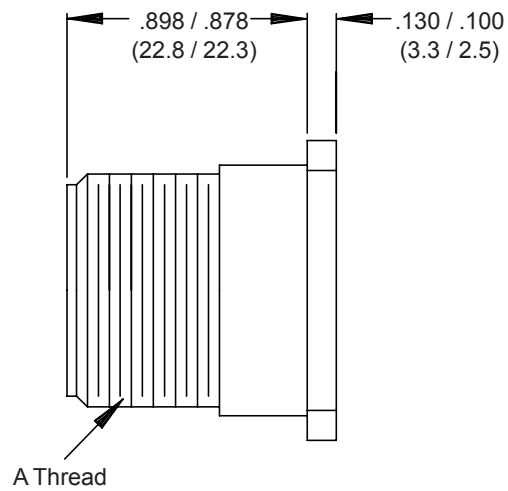
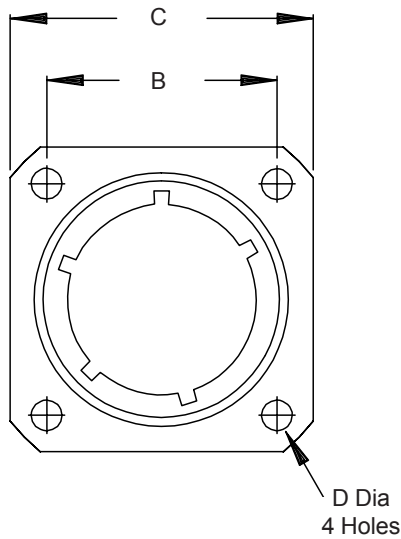
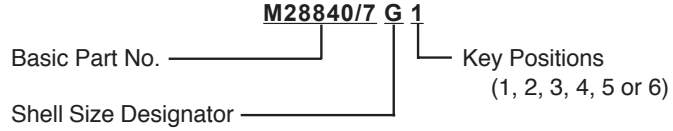

TABLE I

Shell Size Designator	Shell Size Ref.	E Thread	B Dim	C Max	D Max
A	11	0.750-0.1P-0.2L-DS	.750 (19.1)	1.043 (26.5)	.130 (3.3)
B	13	0.875-0.1P-0.2L-DS	.843 (21.4)	1.158 (29.4)	.130 (3.3)
C	15	1.062-0.1P-0.2L-DS	.968 (24.6)	1.278 (32.5)	.130 (3.3)
D	17	1.125-0.1P-0.2L-DS	1.015 (25.8)	1.403 (35.6)	.130 (3.3)
E	19	1.312-0.1P-0.2L-DS	1.140 (29.0)	1.528 (38.8)	.130 (3.3)
F	23	1.500-0.1P-0.2L-DS	1.281 (32.5)	1.738 (44.1)	.130 (3.3)
G	25	1.625-0.1P-0.2L-DS	1.392 (35.4)	1.838 (46.7)	.157 (4.0)
H	29	1.812-0.1P-0.2L-DS	1.568 (39.8)	2.158 (54.8)	.157 (4.0)
J	33	2.000-0.1P-0.2L-DS	1.734 (44.0)	2.348 (59.6)	.183 (4.6)

1. For complete dimensions see applicable Military Specification.
2. Metric dimensions (mm) are indicated in parentheses.
3. Finish is cadmium olive drab over electroless nickel (500 hour salt spray).

M38999/9 Dummy Stowage Receptacle



Dummy
Stowage
Receptacles

Mating Connector
MIL-DTL-38999
Series I

M38999/9-11 B
Basic Part No. _____
Shell Size _____
Finish
B = Cadmium Olive Drab
over Electroless Nickel

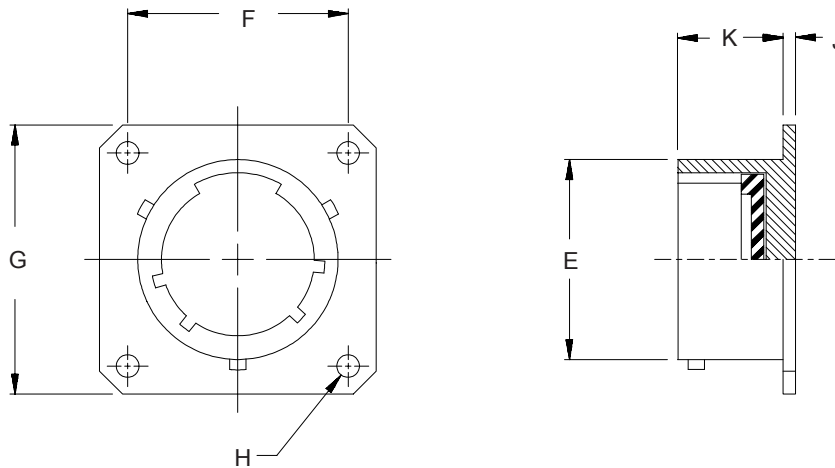

TABLE I

Shell Size	E Max	F Dim	G Max	H Nom	J Max	K ±.010 (.3)
9	.572 (14.5)	.719 (18.3)	.958 (24.3)	.128 (3.3)	.085 (2.2)	.727 (18.5)
11	.701 (17.8)	.812 (20.6)	1.051 (26.7)	.128 (3.3)	.085 (2.2)	.727 (18.5)
13	.851 (21.6)	.906 (23.0)	1.145 (29.1)	.128 (3.3)	.085 (2.2)	.727 (18.5)
15	.976 (24.8)	.969 (24.6)	1.239 (31.5)	.128 (3.3)	.085 (2.2)	.727 (18.5)
17	1.101 (28.0)	1.062 (27.0)	1.332 (33.8)	.128 (3.3)	.085 (2.2)	.727 (18.5)
19	1.208 (30.7)	1.156 (29.4)	1.458 (37.0)	.128 (3.3)	.085 (2.2)	.727 (18.5)
21	1.333 (33.9)	1.250 (31.8)	1.582 (40.2)	.128 (3.3)	.115 (2.9)	.697 (17.7)
23	1.458 (37.0)	1.375 (34.9)	1.708 (43.4)	.147 (3.7)	.115 (2.9)	.697 (17.7)
25	1.583 (40.2)	1.500 (38.1)	1.832 (46.5)	.147 (3.7)	.115 (2.9)	.697 (17.7)

1. For complete dimensions see applicable Military Specification.
2. Metric dimensions (mm) are indicated in parentheses.

Mating Connector
MIL-DTL-38999
Series II

M38999/10-12 B
Basic Part No. _____
Shell Size _____
Finish
B = Cadmium Olive Drab
over Electroless Nickel

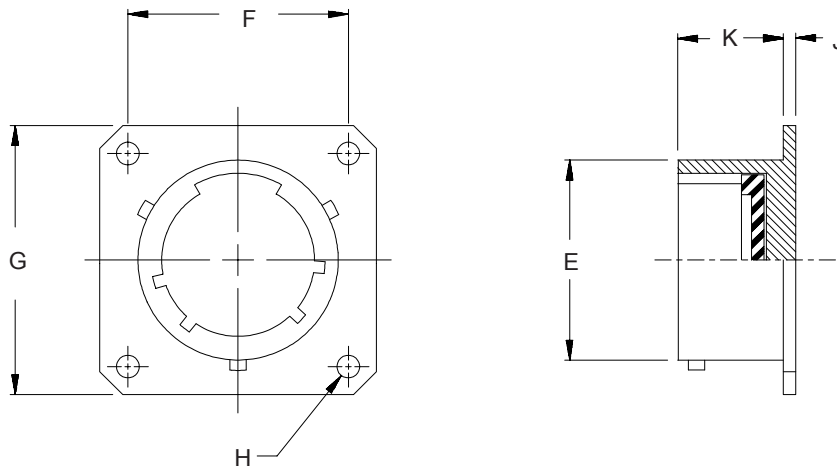

TABLE I								
Shell Size	E Max	F	G Max	H Nom	J Max	K ±.010 (.3)		
8	.474 (12.0)	.594 (15.1)	.828 (21.0)	.120 (3.0)	.069 (1.8)	.451 (11.5)		
10	.591 (15.0)	.719 (18.3)	.954 (24.2)	.120 (3.0)	.069 (1.8)	.451 (11.5)		
12	.751 (19.1)	.812 (20.6)	1.047 (26.6)	.120 (3.0)	.069 (1.8)	.451 (11.5)		
14	.876 (22.3)	.906 (23.0)	1.141 (29.0)	.120 (3.0)	.069 (1.8)	.451 (11.5)		
16	1.001 (25.4)	.969 (24.6)	1.234 (31.3)	.120 (3.0)	.069 (1.8)	.451 (11.5)		
18	1.126 (28.6)	1.062 (27.0)	1.328 (33.7)	.120 (3.0)	.069 (1.8)	.451 (11.5)		
20	1.251 (31.8)	1.156 (29.4)	1.453 (36.9)	.120 (3.0)	.069 (1.8)	.451 (11.5)		
22	1.376 (35.0)	1.250 (31.8)	1.578 (40.1)	.120 (3.0)	.069 (1.8)	.451 (11.5)		
24	1.501 (38.1)	1.375 (34.9)	1.703 (43.3)	.147 (3.7)	.069 (1.8)	.451 (11.5)		

1. For complete dimensions see applicable Military Specification.
2. Metric dimensions (mm) are indicated in parentheses.

D38999/22 Dummy Stowage Receptacle



Dummy
Stowage
Receptacles

Mating Connector
MIL-DTL-38999
Series III

D38999/22 B W
 Basic Part No. _____
 Shell Size Code _____
 Class Per Spec. (Finish is Cadmium Olive Drab Over Electroless Nickel)

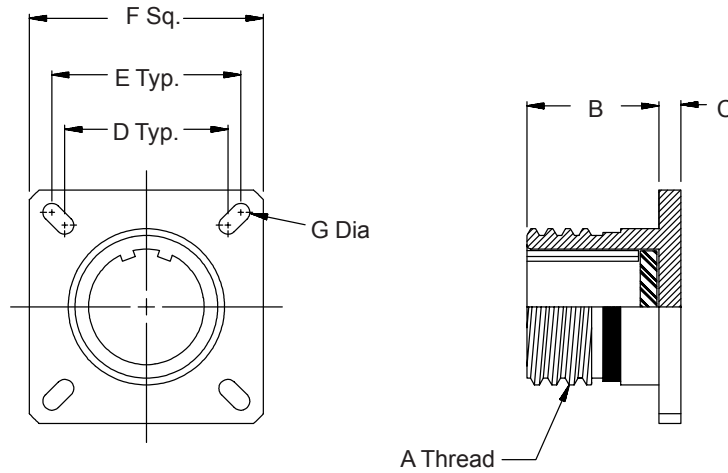

TABLE I

Shell Size Code	Shell Size Ref.	A Thread	B -0.0	C	D
A	9	.625-.1P-3LTS	.823 (20.9)	.098 (2.5)	.594 (15.09)
B	11	.750-.1P-3LTS	.823 (20.9)	.098 (2.5)	.719 (18.26)
C	13	.875-.1P-3LTS	.823 (20.9)	.098 (2.5)	.812 (20.62)
D	15	1.000-.1P-3LTS	.823 (20.9)	.098 (2.5)	.906 (23.01)
E	17	1.187-.1P-3LTS	.823 (20.9)	.098 (2.5)	.969 (24.61)
F	19	1.250-.1P-3LTS	.823 (20.9)	.098 (2.5)	1.062 (26.97)
G	21	1.375-.1P-3LTS	.791 (20.1)	.126 (3.2)	1.156 (29.36)
H	23	1.500-.1P-3LTS	.791 (20.1)	.126 (3.2)	1.250 (31.75)
J	25	1.625-.1P-3LTS	.791 (20.1)	.126 (3.2)	1.375 (34.93)

TABLE II

Shell Size Code	Shell Size Ref.	E	F	G Dia
A	9	.719 (18.26)	.937 (23.8)	.128 (3.25)
B	11	.812 (20.62)	1.031 (26.2)	.128 (3.25)
C	13	.906 (23.01)	1.126 (28.6)	.128 (3.25)
D	15	.969 (24.61)	1.220 (31.0)	.128 (3.25)
E	17	1.062 (26.97)	1.311 (33.3)	.128 (3.25)
F	19	1.156 (29.36)	1.437 (36.5)	.128 (3.25)
G	21	1.250 (31.75)	1.563 (39.7)	.128 (3.25)
H	23	1.375 (34.93)	1.689 (42.9)	.154 (3.91)
J	25	1.500 (38.10)	1.811 (46.0)	.154 (3.91)

1. For complete dimensions see applicable Military Specification.
2. Metric dimensions (mm) are indicated in parentheses.

D38999/50 Dummy Storage Receptacle

Mating Connector
MIL-DTL-38999
Series IV

D38999/50 B W
 Basic Part No. _____
 Shell Size Code _____
 Class Per Spec. (Finish is Cadmium Olive Drab Over Electroless Nickel)

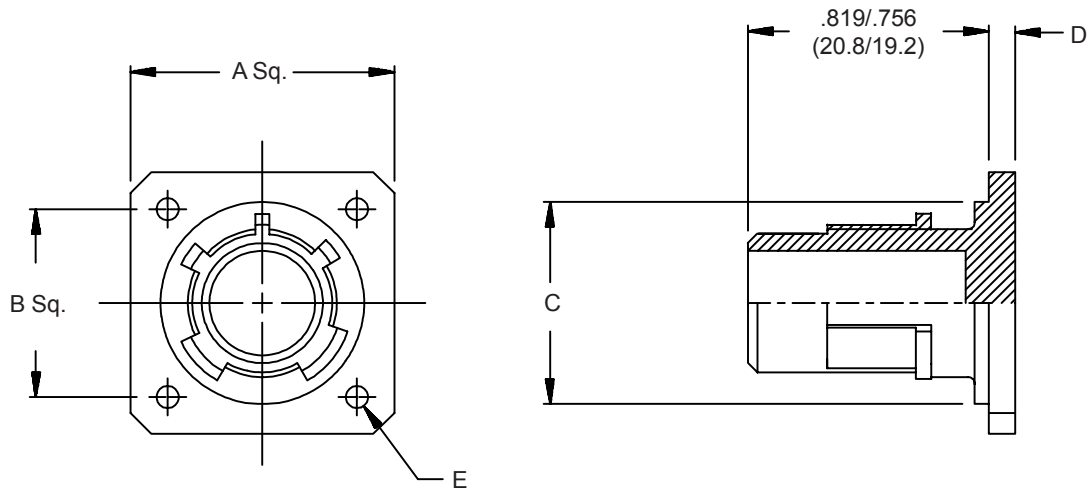

TABLE I

Shell Size Code	Shell Size Ref.	A		B		C		D		E Dia	
		± 0.043	(± 1.10)	BSC		+ 0	(0.00)	± 0.010	$(\pm .25)$	± 0.008	(± 0.2)
B	11	1.030	(26.15)	.812	(20.62)	.793	(20.15)	.093	(2.35)	.130	(3.3)
C	13	1.124	(28.55)	.906	(23.02)	.919	(23.35)	.093	(2.35)	.130	(3.3)
D	15	1.219	(30.95)	.969	(24.62)	1.044	(26.52)	.093	(2.35)	.130	(3.3)
E	17	1.313	(33.35)	1.062	(26.98)	1.170	(29.72)	.093	(2.35)	.130	(3.3)
F	19	1.439	(36.55)	1.156	(29.36)	1.294	(32.87)	.093	(2.35)	.130	(3.3)
G	21	1.561	(39.65)	1.250	(31.76)	1.419	(36.05)	.124	(3.15)	.130	(3.3)
H	23	1.687	(42.85)	1.375	(34.92)	1.544	(39.22)	.124	(3.15)	.142	(3.6)
J	25	1.813	(46.05)	1.500	(38.10)	1.669	(42.40)	.124	(3.15)	.142	(3.6)

1. For complete dimensions see applicable Military Specification.
2. Metric dimensions (mm) are indicated in parentheses.

M81511/19 Dummy Stowage Receptacle



Dummy
Stowage
Receptacles

Mating Connector
MIL-C-81511
Series 2

M81511/19-14-1
 Basic Part No. _____
 Shell Size _____
 Finish:
 1 = Cadmium Olive Drab
 2 = Dull Chromium over Nickel

Inactive for New Design

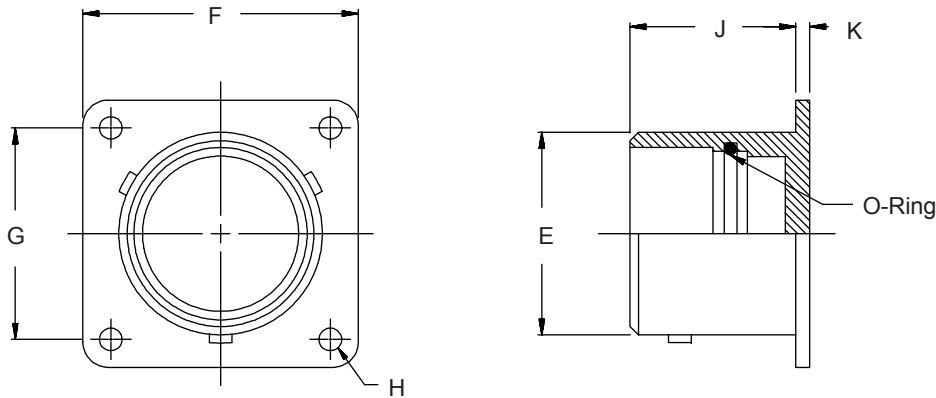

TABLE I

Shell Size	E Dia ±.003 (.1)	F Sq. ±.008 (.2)	G Sq. ±.005 (.1)	H ±.005 (.1)	J ±.010 (.3)	K ±.005 (.1)
08	.550 (14.0)	.812 (20.6)	.594 (15.1)	.121 (3.1)	.645 (16.4)	.070 (1.8)
10	.675 (17.1)	.937 (23.8)	.719 (18.3)	.121 (3.1)	.645 (16.4)	.070 (1.8)
14	.925 (23.5)	1.125 (28.6)	.906 (23.0)	.121 (3.1)	.645 (16.4)	.070 (1.8)
16	1.051 (26.7)	1.250 (31.8)	.969 (24.6)	.121 (3.1)	.645 (16.4)	.070 (1.8)
18	1.175 (29.8)	1.343 (34.1)	1.062 (27.0)	.121 (3.1)	.645 (16.4)	.070 (1.8)

1. For complete dimensions see applicable Military Specification.
2. Metric dimensions (mm) are indicated in parentheses.

M81511/30 Dummy Storage Receptacle

Mating Connector
MIL-C-81511
Series 1

M81511/30-14-1

Basic Part No. _____

Shell Size _____

Finish:

1 = Cadmium Olive Drab

2 = Dull Chromium over Nickel

Inactive for New Design

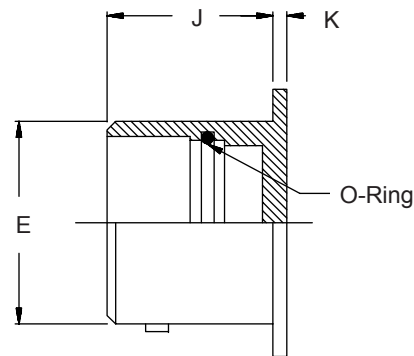
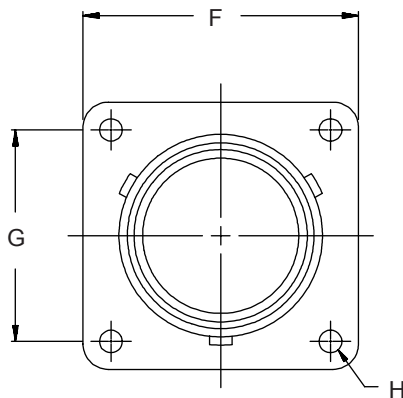

TABLE I

Shell Size	E Dia		F Sq.		G Sq.		H		J		K	
	±.003	(.1)	±.008	(.2)	±.005	(.1)	±.005	(.1)	±.010	(.3)	±.005	(.1)
08	.550	(14.0)	.812	(20.6)	.594	(15.1)	.121	(3.1)	.645	(16.4)	.070	(1.8)
10	.675	(17.1)	.937	(23.8)	.719	(18.3)	.121	(3.1)	.645	(16.4)	.070	(1.8)
14	.925	(23.5)	1.125	(28.6)	.906	(23.0)	.121	(3.1)	.645	(16.4)	.070	(1.8)
16	1.051	(26.7)	1.250	(31.8)	.969	(24.6)	.121	(3.1)	.645	(16.4)	.070	(1.8)
18	1.175	(29.8)	1.343	(34.1)	1.062	(27.0)	.121	(3.1)	.645	(16.4)	.070	(1.8)
20	1.300	(33.0)	1.467	(37.3)	1.156	(29.4)	.121	(3.1)	.645	(16.4)	.070	(1.8)
22	1.425	(36.2)	1.562	(39.7)	1.250	(31.8)	.121	(3.1)	.645	(16.4)	.070	(1.8)
24	1.550	(39.4)	1.703	(43.3)	1.375	(34.9)	.148	(3.8)	.645	(16.4)	.070	(1.8)

1. For complete dimensions see applicable Military Specification.
2. Metric dimensions (mm) are indicated in parentheses.

M83723/61, MS27296 and MS27297 Dummy Stowage Receptacles



Dummy
Stowage
Receptacles

Mating Connector MIL-DTL-26500

M83723/61-1 18 A

Basic Part No. _____
 M83723/61-1 Threaded Coupling
 M83723/61-2 Bayonet Coupling

Shell Size _____

Finish
 A = Black Anodize
 R = Electroless Nickel
 W = Cadmium Olive Drab
 Over Electroless Nickel

MS27296-5 **Superseded Part Number**

Basic Part No. _____
 MS27296 Threaded Coupling
 MS27297 Bayonet Coupling

Dash No. _____

M83723/61-1 MS27296

M83723/61-2 MS27297

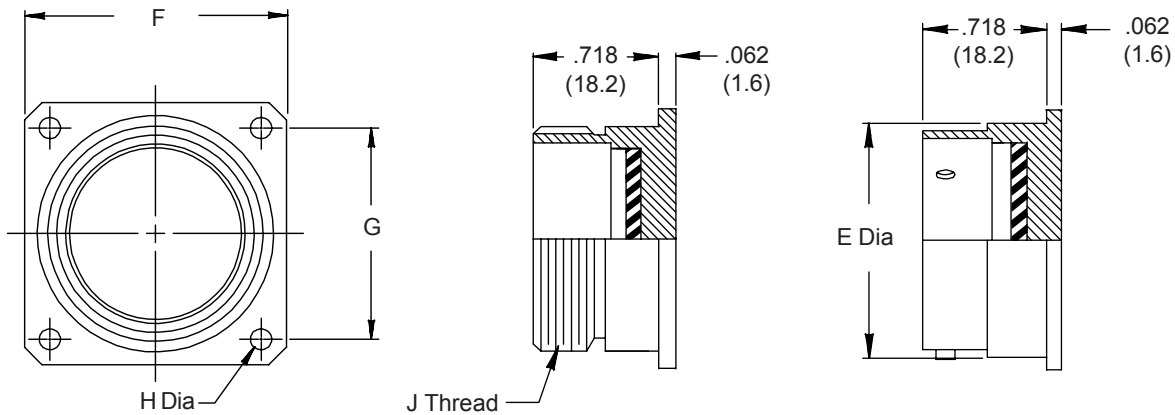
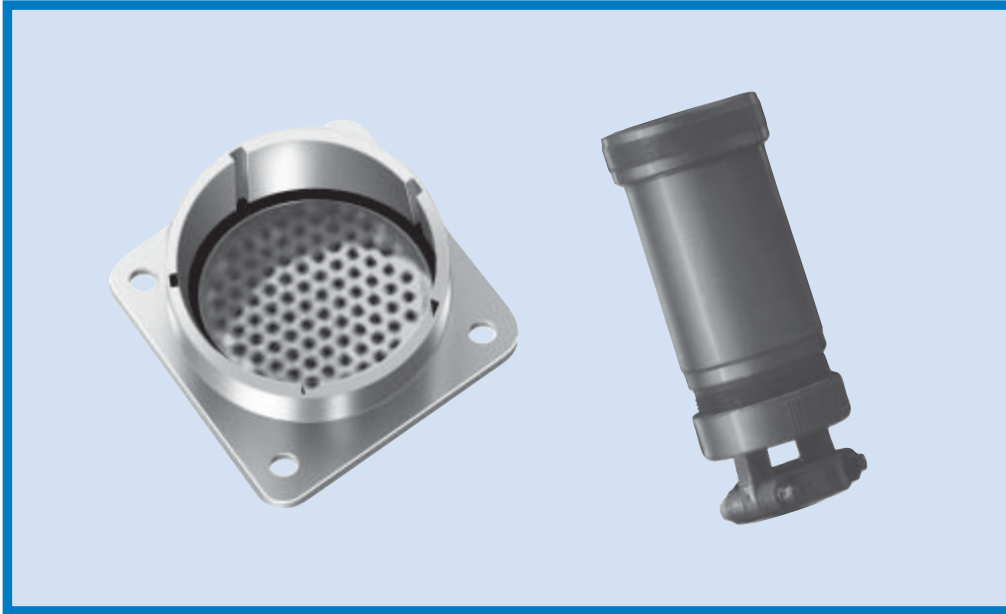

TABLE I

M83723 Shell Size	MS27296 MS27297 Dash No.	E Max Dia	F Dim	G Dim	H Max Dia	J Thread
8	7	.561 (14.2)	.812 (20.6)	.594 (15.1)	.125 (3.2)	9/16 - 24 UNEF
10	1	.696 (17.7)	.937 (23.8)	.719 (18.3)	.125 (3.2)	11/16 - 24 UNEF
12	2	.875 (22.2)	1.031 (26.2)	.812 (20.6)	.125 (3.2)	7/8 - 20 UNEF
14	3	.935 (23.7)	1.125 (28.6)	.906 (23.0)	.125 (3.2)	15/16 - 20 UNEF
16	4	1.062 (27.0)	1.250 (31.8)	.969 (24.6)	.125 (3.2)	1 1/16 - 18 UNEF
18	5	1.187 (30.1)	1.343 (34.1)	1.062 (27.0)	.125 (3.2)	1 3/16 - 18 UNEF
20	8	1.312 (33.3)	1.437 (36.5)	1.156 (29.4)	.125 (3.2)	1 5/16 - 18 UNEF
22	6	1.437 (36.5)	1.562 (39.7)	1.250 (31.8)	.125 (3.2)	1 7/16 - 18 UNEF
24	9	1.562 (39.7)	1.703 (43.3)	1.375 (34.9)	.154 (3.9)	1 9/16 - 18 UNEF

1. For complete dimensions see applicable Military Specification.
2. Metric dimensions (mm) are indicated in parentheses.
3. MS27296 and MS27297 finish is black anodize

Shipboard Interconnect Requirements?



Glenair is MIL-C-28840 Qualified

The standard connector series for shipboard use, MIL-C-28840 offers high-density insert arrangement and high-shock performance. Glenair's qualified product line is now fully tooled and many popular part numbers are in stock, ready for same-day shipment. The MIL-C-28840 features RFI/EMI shielding, scoop-proof shells and corrosion-resistant materials and finishes. In addition to all the connector

types and styles, Glenair makes all the backshell accessory slash numbers as well. The addition of the MIL-C-28840 connector product line is part of Glenair's total commitment to meeting all your shipboard interconnect requirements. So when you think M28840, think Glenair—from connectors to accessories. Please call the factory, or see our website, for order information.



1211 Air Way
Glendale, California 91201-2497
Telephone: 818-247-6000 · Facsimilie: 818-500-9912 · EMail: sales@glenair.com

United States · United Kingdom · Germany · Nordic · France · Spain · Italy

www.glenair.com

Protective Covers



A wide selection of protective covers are offered for almost all bayonet or threaded coupled circular connectors. Glenair's proprietary versions (as shown in Glenair's *Circular Connector Accessories* catalog) offer a broad choice of attachments not provided on the Military Standard versions. EMI/RFI protective covers are offered for most bayonet coupled receptacle connectors. Glenair's *Circular Connector Accessories* catalog is available upon request or visit our web site at www.glenair.com.

Military Specification	Superceeding Part Number	Glenair's Commercial Catalog P/N	Description	Connector Interface	Page Number
MS3180		660-008	Protective Cover, Plug	MIL-DTL-26482	66-2
MS3181		660-009	Protective Cover, Recept.	MIL-DTL-26482	66-2
MS17349		660-007	Protective Cover, Recept.	MIL-DTL-22992	66-3
MS17350		660-006	Protective Cover, Plug	MIL-DTL-22992	66-3
MS20047	MS27502	660-014	Protective Cover, Recept.	MIL-DTL-38999 Series I	66-5*
MS20048	MS27501	660-013	Protective Cover, Plug	MIL-DTL-38999 Series I	66-5*
MS25042		660-004	Protective Cover, Plug	MIL-DTL-5015	66-4
MS25043		660-005	Protective Cover, Recept.	MIL-DTL-5015	66-4
MS27292	M83723/59-1	660-021	Protective Cover, Plug	MIL-DTL-83723 Series III Thd	66-10
MS27293	M83723/59-2	660-019	Protective Cover, Plug	MIL-DTL-83723 Series III Bay.	66-11
MS27294	M83723/60-1	660-022	Protective Cover, Recept.	MIL-DTL-83723 Series III Thd	66-10
MS27295	M83723/60-2	660-020	Protective Cover, Recept.	MIL-DTL-83723 Series III Bay.	66-11
MS27352	MS27510	660-014	Protective Cover, Plug	MIL-DTL-38999 Series II	66-6*
MS27353	MS27511	660-015	Protective Cover, Recept.	MIL-DTL-38999 Series II	66-6*
MS27501		660-012	Protective Cover, Plug	MIL-DTL-38999 Series I	66-5
MS27502		660-013	Protective Cover, Recept.	MIL-DTL-38999 Series I	66-5
MS27510		660-014	Protective Cover, Plug	MIL-DTL-38999 Series II	66-6
MS27511		660-015	Protective Cover, Recept.	MIL-DTL-38999 Series II	66-6
M28840/13		660-010	Protective Cover, Recept.	MIL-C-28840	66-7
M28840/15		660-011	Protective Cover, Plug	MIL-C-28840	66-7
D38999/32		660-023	Protective Cover, Plug	MIL-DTL-38999 Series III	66-8
D38999/33		660-024	Protective Cover, Recept.	MIL-DTL-38999 Series III	66-8
M81511/17		660-017	Protective Cover, Plug	MIL-C-81511 Series 2	66-9
M81511/18		660-018	Protective Cover, Recept.	MIL-C-81511 Series 1 and 2	66-9
M81511/29		660-016	Protective Cover, Plug	MIL-C-81511 Series 1	66-9
M83723/44	MS3181	660-009	Protective Cover, Recept.	MIL-DTL-26482	66-2*
M83723/46	MS3180	660-008	Protective Cover, Plug	MIL-DTL-26482	66-2*
M83723/59-1		660-021	Protective Cover, Plug	MIL-DTL-83723 Series III Thd	66-10
M83723/59-2		660-019	Protective Cover, Plug	MIL-DTL-83723 Series III Bay.	66-11
M83723/60-1		660-022	Protective Cover, Recept.	MIL-DTL-83723 Series III Thd	66-10
M83723/60-2		660-020	Protective Cover, Recept.	MIL-DTL-83723 Series III Bay.	66-11
MS90563		660-007	Protective Cover, Recept.	MIL-C-22992	66-12
MS90564		660-006	Protective Cover, Plug	MIL-C-22992	66-12

* Page Number of Superceeding Part Number

** Consult Factory

MS3180 and MS3181 Protective Covers

MIL-DTL-26482

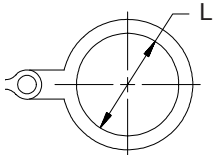

**MS3181 Optional
Ring Attachment**

MS3180-12 C A L

Basic Part No. _____
 MS3180 = Plug Cover
 MS3181 = Receptacle Cover

Shell Size _____

Attachment Option _____
 C = Chain
 N = Chain with Ring (MS3181 Only)
 R = Wire Rope

Length
 L = Chain or Rope Length of 5 inches
 (127.0 mm) Omit for Standard (See K in
 Table)

Finish
 A = Anodize

MS3180-12 C **Prior Revision "D" Available**

Basic Part No. _____
 MS3180 = Plug Cover
 MS3181 = Receptacle Cover

Shell Size _____

Attachment Option (Omit For No Attachment)
 C = Chain
 N = Chain with Ring (MS3181 Only)

Note: Finish is Cadmium Olive Drab

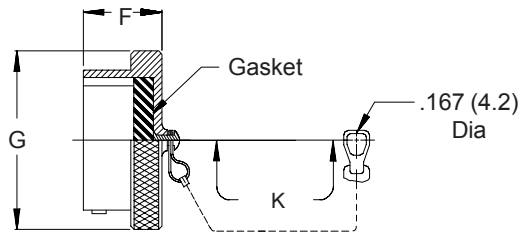

MS3180 Plug Cover

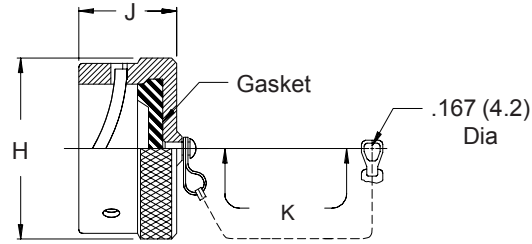

MS3181 Receptacle Cover

TABLE I

Shell Size	F Max	G Dia Max	H Dia Max	J Max	K Standard Length	L Min
8	.562 (14.3)	.719 (18.3)	.734 (18.6)	.562 (14.3)	3.00 (76.2)	.578 (14.7)
10	.562 (14.3)	.844 (21.4)	.859 (21.8)	.562 (14.3)	3.00 (76.2)	.703 (17.9)
12	.562 (14.3)	1.000 (25.4)	1.000 (25.4)	.562 (14.3)	3.50 (88.9)	.891 (22.6)
14	.562 (14.3)	1.125 (28.6)	1.125 (28.6)	.562 (14.3)	3.50 (88.9)	1.016 (25.8)
16	.562 (14.3)	1.250 (31.8)	1.250 (31.8)	.562 (14.3)	3.50 (88.9)	1.141 (29.0)
18	.562 (14.3)	1.375 (34.9)	1.375 (34.9)	.562 (14.3)	3.50 (88.9)	1.266 (32.2)
20	.625 (15.9)	1.500 (38.1)	1.500 (38.1)	.562 (14.3)	4.00 (101.6)	1.391 (35.3)
22	.625 (15.9)	1.625 (41.3)	1.625 (41.3)	.562 (14.3)	4.00 (101.6)	1.516 (38.5)
24	.658 (16.7)	1.750 (44.5)	1.750 (44.5)	.602 (15.3)	4.00 (101.6)	1.641 (41.7)

1. For complete dimensions see applicable Military Specification.
2. Metric dimensions (mm) are indicated in parentheses.

MS17349 and MS17350 Protective Covers



Protective
Covers

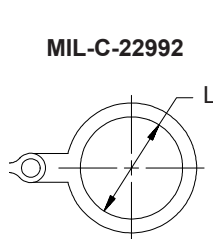

MS17349 Attachment Type A

MS17349 C 28 A

Basic Part No. _____
 MS17349 = Receptacle Cover
 MS17350 = Plug Cover

Attachment Type
 (MS17349 Only)

Dash No. _____

Finish _____
 C = Conductive
 N = Non-Conductive

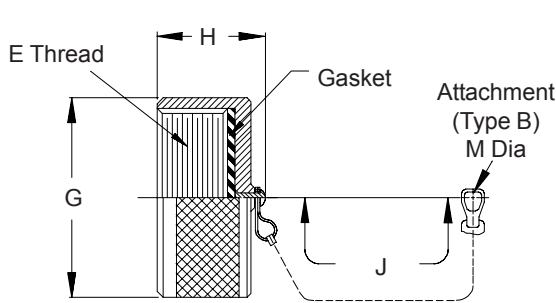

MS17349 Receptacle Cover

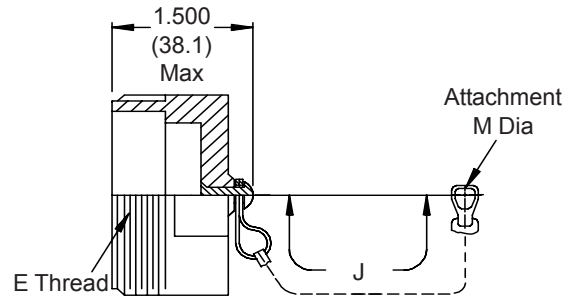

MS17350 Plug Cover

TABLE I

Dash No.	E Thread	G Max	H Max	J Chain Length	L Min.	M Dia Min.
12	.8750-0.1P-0.2L-DS	1.094 (27.8)	.765 (19.4)	5.00 (127.0)	1.016 (25.8)	.150 (3.8)
14	1.0000-0.1P-0.2L-DS	1.219 (31.0)	.765 (19.4)	5.00 (127.0)	1.141 (29.0)	.150 (3.8)
16	1.1250-0.1P-0.2L-DS	1.344 (34.1)	.980 (24.9)	5.00 (127.0)	1.266 (32.2)	.150 (3.8)
18	1.2500-0.1P-0.2L-DS	1.469 (37.3)	.980 (24.9)	5.00 (127.0)	1.391 (35.3)	.177 (4.5)
20	1.3750-0.1P-0.2L-DS	1.562 (39.7)	.980 (24.9)	5.00 (127.0)	1.516 (38.5)	.177 (4.5)
22	1.5000-0.1P-0.2L-DS	1.688 (42.9)	.980 (24.9)	6.00 (152.4)	1.641 (41.7)	.177 (4.5)
24	1.7500-0.1P-0.2L-DS	1.938 (49.2)	.980 (24.9)	6.00 (152.4)	1.891 (48.0)	.177 (4.5)
28	2.0000-0.1P-0.2L-DS	2.219 (56.4)	.980 (24.9)	6.00 (152.4)	2.141 (54.4)	.177 (4.5)
32	2.2500-0.1P-0.2L-DS	2.469 (62.7)	.980 (24.9)	6.00 (152.4)	2.391 (60.7)	.199 (5.1)
36	2.5000-0.1P-0.2L-DS	2.719 (69.1)	.980 (24.9)	6.00 (152.4)	2.641 (67.1)	.199 (5.1)
40	2.7500-0.1P-0.2L-DS	2.969 (75.4)	.980 (24.9)	6.00 (152.4)	2.891 (73.4)	.199 (5.1)
44	3.0000-0.1P-0.2L-DS	3.219 (81.8)	.980 (24.9)	6.00 (152.4)	3.141 (79.8)	.199 (5.1)

1. For complete dimensions see applicable Military Specification.
2. Metric dimensions (mm) are indicated in parentheses.

**MS25042 and MS25043
Protective Covers**
MIL-DTL-5015

MS25042-20D A
 Basic Part No. ————
 MS25042 = Plug Cover
 MS25043 = Receptacle Cover
 Finish
 A = Black Anodize
 Shell Size

MS25042-20D **Prior Revision Available**
 Basic Part No. ————
 MS25042 = Plug Cover
 MS25043 = Receptacle Cover
 Shell Size
 Finish is Cadmium Olive Drab

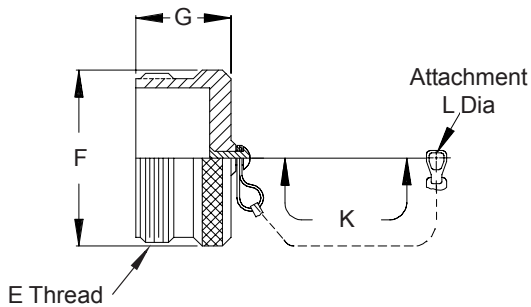
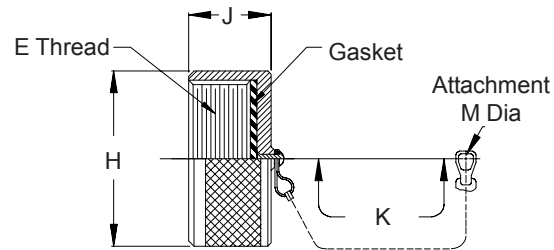
MS25042 Plug Cover

MS25043 Receptacle Cover
TABLE I

Shell Size	E Thread	F Dia Max	G Max	H Max	J Max	K Attachment Length	L Dia Min	M Dia Min
8D	1/2 - 28 UNEF	.562 (14.3)	.656 (16.7)	.688 (17.5)	.469 (11.9)	4.00 (101.6)	.151 (3.8)	.135 (3.4)
10D	5/8 - 24 UNEF	.687 (17.4)	.656 (16.7)	.815 (20.7)	.469 (11.9)	4.00 (101.6)	.151 (3.8)	.135 (3.4)
12D	3/4 - 20 UNEF	.812 (20.6)	.844 (21.4)	1.000 (25.4)	.469 (11.9)	4.50 (114.3)	.151 (3.8)	.135 (3.4)
14D	7/8 - 20 UNEF	.937 (23.8)	.844 (21.4)	1.125 (28.6)	.469 (11.9)	4.50 (114.3)	.151 (3.8)	.135 (3.4)
16D	1 - 20 UNEF	1.062 (27.0)	.844 (21.4)	1.188 (30.2)	.469 (11.9)	4.50 (114.3)	.151 (3.8)	.135 (3.4)
18D	1 1/8 - 18 UNEF	1.187 (30.1)	.844 (21.4)	1.344 (34.1)	.469 (11.9)	4.50 (114.3)	.151 (3.8)	.135 (3.4)
20D	1 1/4 - 18 UNEF	1.312 (33.3)	.844 (21.4)	1.469 (37.3)	.469 (11.9)	5.00 (127.0)	.182 (4.6)	.135 (3.4)
22D	1 3/8 - 18 UNEF	1.437 (36.5)	.844 (21.4)	1.594 (40.5)	.469 (11.9)	5.00 (127.0)	.182 (4.6)	.135 (3.4)
24D	1 1/2 - 18 UNEF	1.562 (39.7)	.844 (21.4)	1.719 (43.7)	.469 (11.9)	5.50 (139.7)	.182 (4.6)	.135 (3.4)
28D	1 3/4 - 18 UNS	1.812 (46.0)	.844 (21.4)	1.969 (50.0)	.531 (13.5)	7.75 (196.9)	.182 (4.6)	.166 (4.2)
32D	2 - 18 UNS	2.062 (52.4)	.844 (21.4)	2.219 (56.4)	.531 (13.5)	7.75 (196.9)	.213 (5.4)	.166 (4.2)
36D	2 1/4 - 16 UN	2.312 (58.7)	.844 (21.4)	2.469 (62.7)	.531 (13.5)	7.75 (196.9)	.213 (5.4)	.182 (4.6)
40D	2 1/2 - 16 UN	2.562 (65.1)	.844 (21.4)	2.719 (69.1)	.531 (13.5)	7.75 (196.9)	.213 (5.4)	.182 (4.6)
44D	2 3/4 - 16 UN	2.812 (71.4)	.844 (21.4)	2.969 (75.4)	.531 (13.5)	7.75 (196.9)	.213 (5.4)	.182 (4.6)
48D	3 - 16 UN	3.062 (77.8)	.844 (21.4)	3.188 (81.0)	.531 (13.5)	7.75 (196.9)	.213 (5.4)	.182 (4.6)

1. For complete dimensions see applicable Military Specification.
2. Metric dimensions (mm) are indicated in parentheses.

MS27501 and MS27502 Protective Covers



Protective
Covers

**MIL-DTL-38999
Series I**

Basic Part No. **MS27501 B 19 C L**

MS27501 = Plug Cover
MS27502 = Receptacle Cover

Finish
A = Gold Iridite Over Cadmium Over Nickel
B = 500 Hour Cadmium Olive Drab
C = Anodize
F = Electroless Nickel

Dash No.

Length (Omit for Standard)
L = 5.0 (127.0)
M = 6.0 (152.4) MS27501 Only
N = 7.0 (177.8) MS27501 Only

Attachment Style
A = No Attachment
C = Chain
N = Chain with Ring (MS27502 Only)

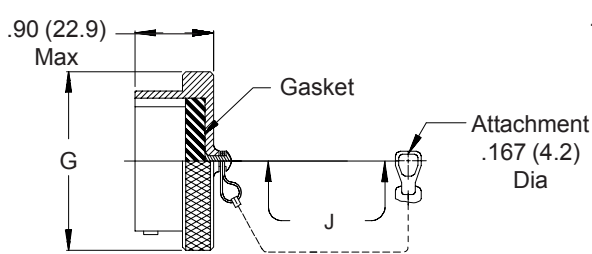

MS27501 Plug Cover

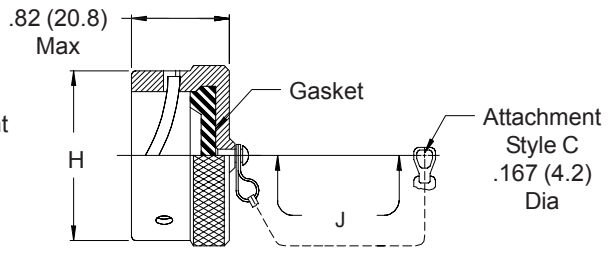

MS27502 Receptacle Cover

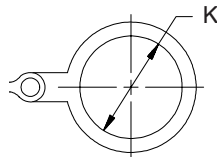

MS27502 Attachment Type N

TABLE I

Shell Size	G Dia Max	H Max	J Nom Length	K Dia Min
9	.820 (20.8)	.82 (20.8)	3.00 (76.2)	.70 (17.8)
11	.940 (23.9)	.94 (23.9)	3.00 (76.2)	.84 (21.3)
13	1.070 (27.2)	1.10 (27.9)	3.50 (88.9)	1.01 (25.7)
15	1.190 (30.2)	1.22 (31.0)	3.50 (88.9)	1.14 (29.0)
17	1.320 (33.5)	1.34 (34.0)	3.50 (88.9)	1.26 (32.0)
19	1.440 (36.6)	1.46 (37.1)	3.50 (88.9)	1.39 (35.3)
21	1.570 (39.9)	1.58 (40.1)	4.00 (101.6)	1.51 (38.4)
23	1.690 (42.9)	1.70 (43.2)	4.00 (101.6)	1.64 (41.7)
25	1.820 (46.2)	1.83 (46.5)	4.00 (101.6)	1.76 (44.7)

1. For complete dimensions see applicable Military Specification.
2. Metric dimensions (mm) are indicated in parentheses.

MS27510 and MS27511 Protective Covers

MIL-C-38999
Series II

MS27510 B 18 C L

Basic Part No. _____
 MS27510 = Plug Cover
 MS27511 = Receptacle Cover

Finish _____
 A = Gold Iridite Over Cadmium Over Nickel
 B = 500 Hour Cadmium Olive Drab
 C = Anodize
 F = Electroless Nickel

Shell Size _____

Length (Omit for Standard)
 L = 5.0 (127.0)
 M = 6.0 (152.4) MS27510 Only
 N = 7.0 (177.8) MS27510 Only

Attachment Style
 A = No Attachment
 C = Chain
 N = Chain with Ring (MS27511 Only)
 R = Rope (MS27511 Only)

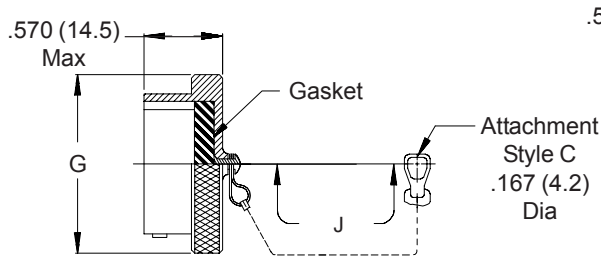

MS27510 Plug Cover

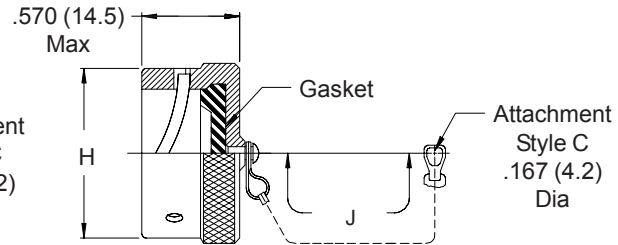

MS27511 Receptacle Cover

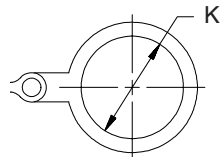

MS27511 Attachment Type N

TABLE I

Shell Size	G Dia Max	H Dia Max	J Nom Length	K Dia Min
8	.720 (18.3)	.630 (16.0)	3.00 (76.2)	.890 (22.6)
10	.850 (21.6)	.761 (19.3)	3.00 (76.2)	1.010 (25.7)
12	1.000 (25.4)	.936 (23.8)	3.00 (76.2)	1.140 (29.0)
14	1.130 (28.7)	1.074 (27.3)	3.50 (88.9)	1.260 (32.0)
16	1.250 (31.8)	1.172 (29.8)	3.50 (88.9)	1.390 (35.3)
18	1.380 (35.1)	1.304 (33.1)	3.50 (88.9)	1.510 (38.4)
20	1.500 (38.1)	1.435 (36.4)	4.00 (101.6)	1.640 (41.7)
22	1.630 (41.4)	1.560 (39.6)	4.00 (101.6)	1.760 (44.7)
24	1.750 (44.5)	1.688 (42.9)	4.00 (101.6)	1.890 (48.0)

1. For complete dimensions see applicable Military Specification.
2. Metric dimensions (mm) are indicated in parentheses.

M28840/13 and M28840/15 Protective Covers



Protective
Covers

MIL-C-28840

Basic Part No. _____ M28840/13 H A W
 M28840/13 = Receptacle Cover
 M28840/15 = Plug Cover
 Material and Finish
 W = Aluminum, 500 Hour
 Cadmium Olive Drab

Shell Size Designator _____

Attachment Style _____
 A = Chain with Fastener
 B = Chain with Ring for Jam Nut Receptacle (M28840/13)
 B = Chain with Ring (M28840/15)
 C = Chain with Ring for Cable Receptacle (M28840/13 Only)

1. For complete dimensions see applicable Military Specification.
2. Metric dimensions (mm) are indicated in parentheses.

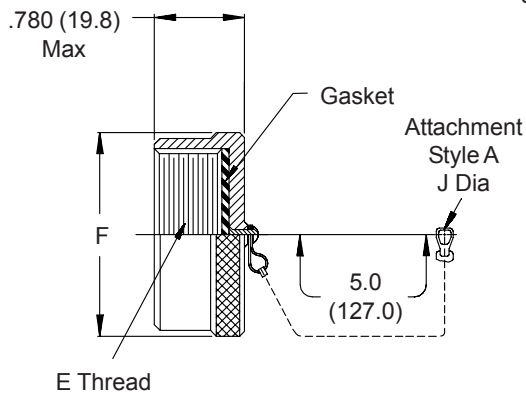

M28840/13 Receptacle Cover

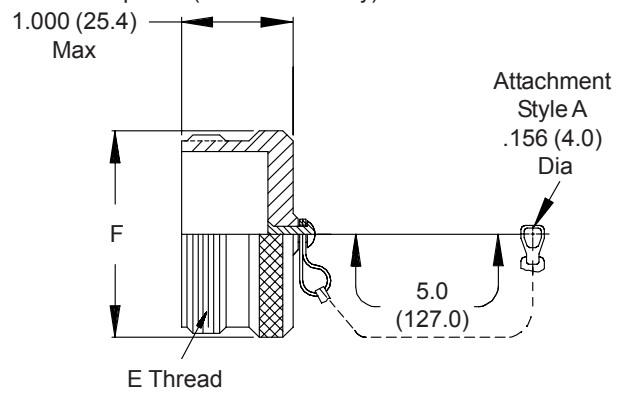

M28840/15 Plug Cover

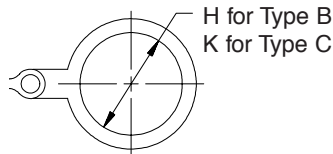

M28840/13 Attachment Types B & C

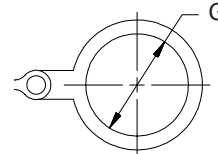

MS28840/15 Attachment Type B

TABLE I

Shell Size Desig.	Shell Size (Ref.)	E Thread	F Max	G Dia ±.010 (.3)	H Dia ±.010 (.3)	J Dia ±.005 (.1)	K Dia ±.010 (.3)
A	11	0.750-0.1P-0.2L-DS	1.028 (26.1)	.765 (19.4)	.890 (22.6)	.130 (3.3)	.765 (19.4)
B	13	0.875-0.1P-0.2L-DS	1.141 (29.0)	.890 (22.6)	1.015 (25.8)	.130 (3.3)	.890 (22.6)
C	15	1.062-0.1P-0.2L-DS	1.263 (32.1)	1.015 (25.8)	1.203 (30.6)	.130 (3.3)	1.015 (25.8)
D	17	1.125-0.1P-0.2L-DS	1.387 (35.2)	1.140 (29.0)	1.265 (32.1)	.130 (3.3)	1.140 (29.0)
E	19	1.312-0.1P-0.2L-DS	1.513 (38.4)	1.265 (32.1)	1.453 (36.9)	.130 (3.3)	1.265 (32.1)
F	23	1.500-0.1P-0.2L-DS	1.703 (43.3)	1.453 (36.9)	1.640 (41.7)	.130 (3.3)	1.453 (36.9)
G	25	1.625-0.1P-0.2L-DS	1.825 (46.4)	1.577 (40.1)	1.765 (44.8)	.156 (4.0)	1.577 (40.1)
H	29	1.812-0.1P-0.2L-DS	2.143 (54.4)	1.890 (48.0)	1.953 (49.6)	.156 (4.0)	1.890 (48.0)
J	33	2.000-0.1P-0.2L-DS	2.329 (59.2)	2.077 (52.8)	2.140 (54.4)	.193 (4.9)	2.077 (52.8)

D38999/32 and D38999/33 Protective Covers

MIL-DTL-38999
Series III
Threaded

D38999/32 W 15 R

Basic Part No. _____
 D38999/32 = Plug Cover
 D38999/33 = Receptacle Cover

Attachment Style (R or N)
 Shell Size

Material and Finish _____
 W = Aluminum, 500 Hour Cadmium Olive Drab
 J = Composite, Cadmium Olive Drab
 M = Composite, Electroless Nickel

**D38999/32
Plug Cover**

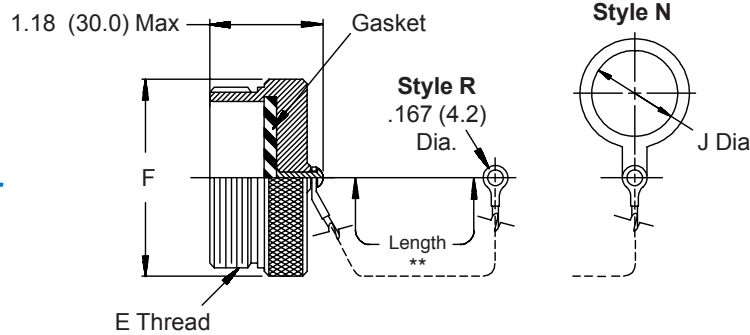

** Rope Length
 5.000 (127.0)
 +.50 (+13.0)
 -.25 (-7.0)

**D38999/33
Receptacle Cover**

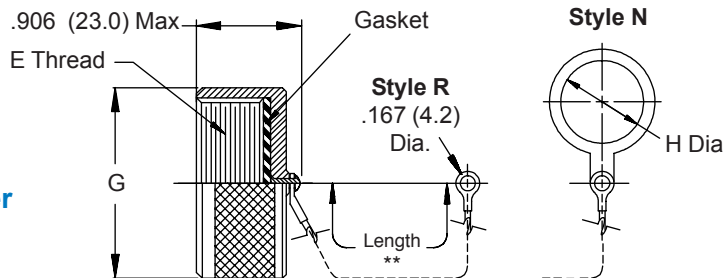

TABLE I

Shell Size	E Thread	F Max	G Max	H Min	J Min
9	.6250-0.1P-0.3L-TS	.906 (23.0)	.906 (23.0)	.694 (17.6)	.512 (13.0)
11	.7500-0.1P-0.3L-TS	1.024 (26.0)	1.102 (28.0)	.865 (22.0)	.709 (18.0)
13	.8750-0.1P-0.3L-TS	1.220 (31.0)	1.220 (31.0)	.989 (25.1)	.787 (20.0)
15	1.0000-0.1P-0.3L-TS	1.300 (33.0)	1.260 (32.0)	1.178 (29.9)	.906 (23.0)
17	1.1875-0.1P-0.3L-TS	1.457 (37.0)	1.457 (37.0)	1.260 (32.0)	1.024 (26.0)
19	1.2500-0.1P-0.3L-TS	1.575 (40.0)	1.535 (39.0)	1.428 (36.3)	1.142 (29.0)
21	1.3750-0.1P-0.3L-TS	1.732 (44.0)	1.654 (42.0)	1.506 (38.3)	1.260 (32.0)
23	1.5000-0.1P-0.3L-TS	1.811 (46.0)	1.772 (45.0)	1.678 (42.6)	1.339 (34.0)
25	1.6250-0.1P-0.3L-TS	1.969 (50.0)	1.929 (49.0)	1.750 (44.5)	1.535 (39.0)

1. For complete dimensions see applicable Military Specification.
2. Metric dimensions (mm) are indicated in parentheses.

M81511/17, M81511/18, and M81511/29 Protective Covers



Protective Covers

MIL-C-81511

Inactive for New Design

Basic Part No. M81511/17-16 Shell Size
 M81511/17 = Plug Cover Series 2
 M81511/18 = Receptacle Cover Series 1 and 2
 M81511/29 = Plug Cover Series 1

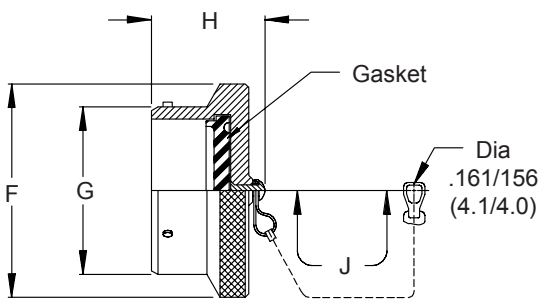

M81511/29 Plug Cover - Series 1
 M81511/17 Plug Cover - Series 2

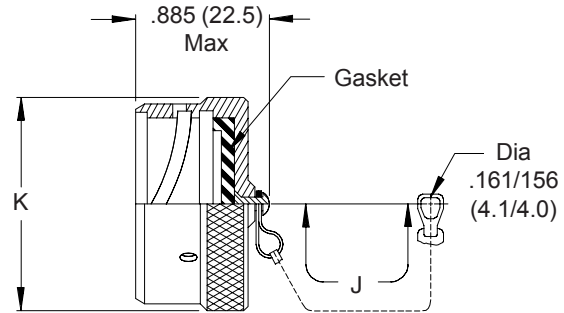

M81511/18 Receptacle Cover Series 1 and 2

TABLE I

Shell Size	F Dia Max	G Dia		H Max		J ± One Link	K Dia Max
		+ .000 (0.0)	- .006 (0.2)	M81511/29	M81511/17		
08	.845 (21.5)	.553 (14.0)		1.125 (28.6)	.985 (25.0)	3.0 (76.2)	.844 (21.4)
10	.970 (24.6)	.678 (17.2)		1.125 (28.6)	.985 (25.0)	3.0 (76.2)	.969 (24.6)
14	1.220 (31.0)	.928 (23.6)		1.125 (28.6)	.985 (25.0)	3.5 (88.9)	1.219 (31.0)
16	1.345 (34.2)	1.054 (26.8)		1.125 (28.6)	.985 (25.0)	3.5 (88.9)	1.345 (34.2)
18	1.470 (37.3)	1.178 (29.9)		1.125 (28.6)	.985 (25.0)	3.5 (88.9)	1.469 (37.3)
20*	1.595 (40.5)	1.303 (33.1)		1.125 (28.6)		3.5 (88.9)	1.594 (40.5)
22*	1.720 (43.7)	1.428 (36.3)		1.125 (28.6)		3.5 (88.9)	1.719 (43.7)
24*	1.845 (46.9)	1.553 (39.4)		1.125 (28.6)		3.5 (88.9)	1.844 (46.8)

* Not Applicable for M81511/17 or M81511/18

1. For complete dimensions see applicable Military Specification.
2. Metric dimensions (mm) are indicated in parentheses.

**M83723/59-1, M83723/60-1, MS27292
and MS27294 Protective Covers**

**MIL-DTL-83723
Series III
Threaded**

M83723/59-1 10 A C

Basic Part No. _____
 M83723/59-1 = Plug Cover
 M83723/60-1 = Receptacle Cover

Shell Size _____

Finish _____
 A = Black Anodize
 R = Electroless Nickel
 W = Cadmium Over Electroless Nickel

Attachment Style
 C = 5.0" (127.0) Chain
 P = 8.0" (203.2) Chain
 R = 5.0" (127.0) Rope
 T = 8.0" (203.2) Rope
 N = No Attachment

MS27292-1

Basic Part No. _____
 MS27292 = Plug Cover
 MS27294 = Receptacle Cover

Dash No. _____

**Superseded Part Number
See Note 3**

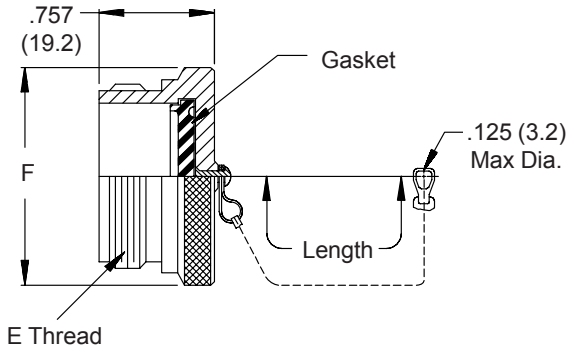

**M83723/59-1 Plug Cover
M27292 Plug Cover (See Note 3)**

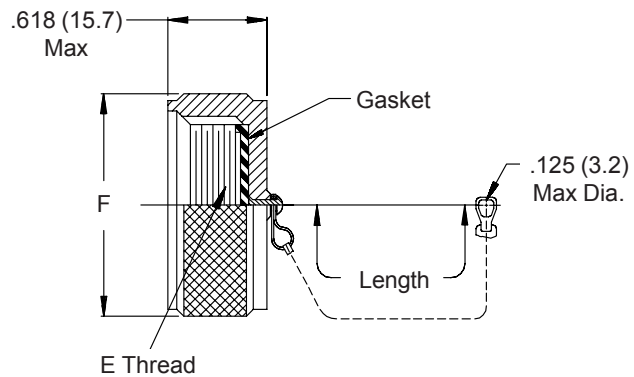

**M83723/60-1 Receptacle Cover
M27294 Receptacle Cover (See Note 3)**

TABLE I

M27292		E Thread Class 2A/2B	F Dia Max
Shell Size	M27293 Dash No.		
8	7	9/16 - 24 UNEF	.776 (19.7)
10	1	11/16 - 24 UNEF	.906 (23.0)
12	2	7/8 - 20 UNEF	1.078 (27.4)
14	3	15/16 - 20 UNEF	1.141 (29.0)
16	4	1 1/16 - 18 UNEF	1.266 (32.2)
18	5	1 3/16 - 18 UNEF	1.375 (34.9)
20	8	1 5/16 - 18 UNEF	1.510 (38.4)
22	6	1 7/16 - 18 UNEF	1.625 (41.3)
24	9	1 9/16 - 18 UNEF	1.760 (44.7)

1. For complete dimensions see applicable Military Specification.
2. Metric dimensions (mm) are indicated in parentheses.
3. MS27292 and MS27294 have a black anodize finish. Dash no.'s 1, 2, and 7 have 3.0" (76.2) wire rope attachment and other dash no.'s have a 5.0" (127.0) wire rope attachment.

**M83723/59-2, M83723/60-2, MS27293
and MS27295 Protective Covers**



Protective
Covers

**MIL-DTL-83723
Series III
Bayonet**

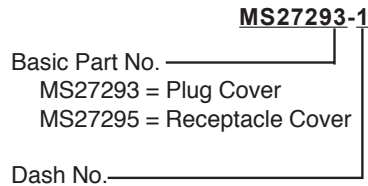
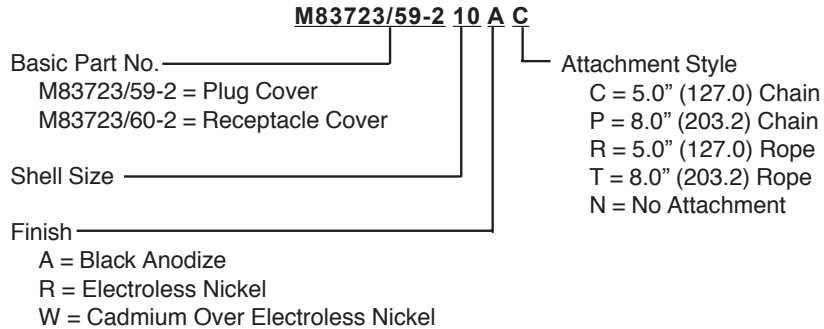

**Superceded Part Number
See Note 3**

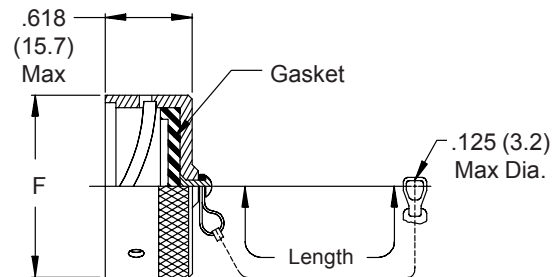
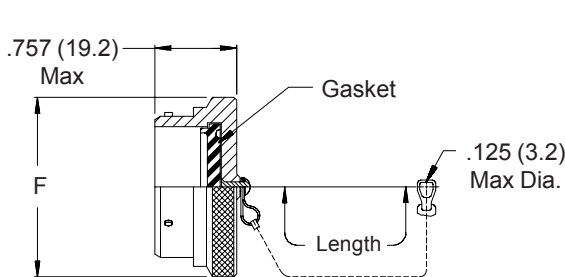

**M83723/59-2 Plug Cover
M27293 Plug Cover (See Note 3)**

**M83723/60-2 Receptacle Cover
M27295 Receptacle Cover (See Note 3)**

TABLE I

Shell Size	M27294 M27295 Dash No.	F Dia Max
8	7	.776 (19.7)
10	1	.906 (23.0)
12	2	1.078 (27.4)
14	3	1.141 (29.0)
16	4	1.266 (32.2)
18	5	1.375 (34.9)
20	8	1.510 (38.4)
22	6	1.625 (41.3)
24	9	1.760 (44.7)

1. For complete dimensions see applicable Military Specification.
2. Metric dimensions (mm) are indicated in parentheses.
3. MS27293 and MS27295 have a black anodize finish. Dash no.'s 1, 2, and 7 have 3.0" (76.2) wire rope attachment and other dash no.'s have a 5.0" (127.0) wire rope attachment.

Miscellaneous Accessories

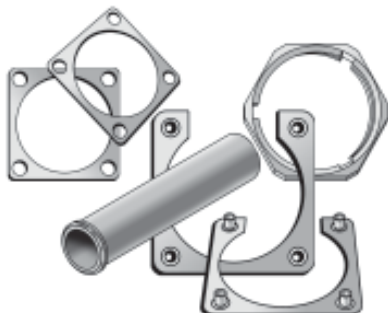

Can't find it anywhere else in the book? This section of the catalog includes miscellaneous accessories such as Jam Nuts, Potting Boots, Gaskets, Bushings and Fiber Optic Termini

Military Specification	Superceding Part Number	Glenair's Commercial Catalog P/N	Description	Page Number
MS3186		**	Jam Nut	68-2
MS3420		**	Telescoping Bushing	68-4
MS27512	MS3186	**	Jam Nut	68-2*
MS27514	MS3186	**	Jam Nut	68-2*
M28840/24		**	Gasket	68-5
M29504/04		181-002	Fiber Optic Pin Terminus	68-6
M29504/05		181-001	Fiber Optic Socket Terminus	68-7
D38999/28		**	Jam Nut	68-8
M83723/70		**	Receptacle Adapter	68-9
AS85049/32-1		**	Adapter, Non-Env., RFI, 90°	68-10
AS85049/32-2		**	Adapter	68-11
AS85049/33-1		**	Adapter, Non-Env., RFI, Straight	68-12
AS85049/74		**	Potting Boot	68-13
AS85049/75		**	Potting Boot	68-14
AS85049/93		687-207	Banding Split Ring	68-15
AS85049/94		**	Mounting Flange, Full Perimeter	68-16
AS85049/95		**	Mounting Flange, 3/4 Perimeter	68-17
AS85049/96		**	Mounting Flange, 1/4 Perimeter	68-18
M85528/1		**	Mounting Flange, Full Perimeter	68-19
M85528/2		**	Mounting Flange, 3/4 Perimeter	68-20
M85528/3		**	Mounting Flange, 1/4 Perimeter	68-18

* Page Number of Superceding Part Number
** Consult Factory

MS3186 Jam Nut

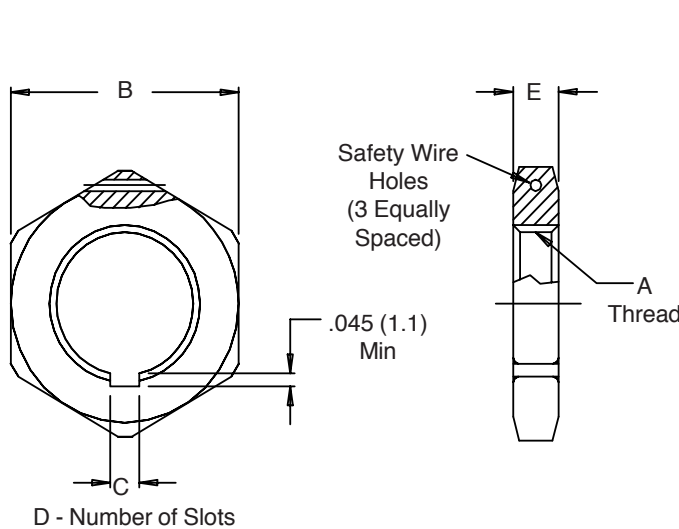

MS3186 A 113 B

- Basic Part No. _____
- Material: _____
 A = Aluminum
 S = Steel
 C = CRES
- Dash No. _____
- Finish: _____
 A = Black Anodize
 B = Black Cadmium over
 Corrosion Resistant Steel
 N = Electroless Nickel (Space
 Use Only)
 P = Passivated
 W = Cadmium Olive Drab
 Over Electroless Nickel

TABLE I

FOR CONNECTOR SHELL SIZE (REF.)

Shell Size	MIL-DTL-5015	MIL-DTL-26482	MIL-DTL-26500	MIL-DTL-83723 I	MIL-DTL-83723 III	MIL-DTL-38999 I	MIL-DTL-38999 II	MIL-C-28840	MIL-C-27599
101	8S	--	--	--	--	--	--	--	--
102	--	8	--	8	--	--	--	--	--
103	10S, 10SL	--	--	--	--	--	--	--	--
104	--	--	8	--	--	--	--	--	--
105	--	--	--	--	8	--	--	--	--
106	--	10	--	10	--	9	--	--	9
107	12S, 12	--	10	--	10	--	--	--	--
108	--	--	--	--	--	11	--	--	11
109	14S, 14	12	--	12	--	--	8	11	8
110	--	--	12	--	12	--	--	--	--
111	16S, 16	14	14	14	14	13	10	13	10, 13
112	--	--	16	--	16 Bay	--	--	--	--
113	18	16	--	16	16 Thd	15	12	--	12, 15
114	--	--	--	--	--	--	--	15	--
115	--	--	18	--	--	--	--	--	14, 17
116	20	18	--	18	18	17	14	17	--
117	22	20	20	20	20	19	16	--	16, 19
118	--	--	--	--	--	--	--	19	--
119	--	--	22	--	--	--	--	--	--
120	24	22	--	22	22	21	18	--	18, 21
121	--	24	24	24	24	23	20	23	20, 23
122	28	--	--	--	--	25	22	25	22, 25
123	--	--	--	--	--	--	24	--	24
124	--	--	--	--	--	--	--	29	--
125	32	--	--	--	--	--	--	--	--
126	--	--	--	--	--	--	--	33	--
127	36	--	--	--	--	--	--	--	--
128	40	--	--	--	--	--	--	--	--
129	44	--	--	--	--	--	--	--	--
130	48	--	--	--	--	--	--	--	--

**MS3186
Jam Nut**



Miscellaneous
Accessories

TABLE II

Shell Size	A Thread	B		C		D Min. No. of Slots	E Dia	
		±.017	(.4)	Max			±.017	(.4)
101	.500 - 28 UNEF-2B	.687	(17.4)	None		None	.125	(3.2)
102	.5625 - 24 UNEF-2B	.750	(19.1)	.135	(3.4)	2	.125	(3.2)
103	.625 - 24 UNEF-2B	.812	(20.6)	None		None	.125	(3.2)
104	.625 - 20 UN-2B	.812	(20.6)	None		None	.125	(3.2)
105	.625 - 20 UN-2B	.812	(20.6)	None		None	.125	(3.2)
106	.6875 - 24 UNEF-2B	.875	(22.2)	.135	(3.4)	1	.125	(3.2)
107	.750 - 20 UNEF-2B	.937	(23.8)	None		None	.125	(3.2)
108	.8125 - 20 UNEF-2B	1.000	(25.4)	.135	(3.4)	1	.125	(3.2)
109	.875 - 20 UNEF-2B	1.062	(27.0)	.135	(3.4)	1	.125	(3.2)
110	.9375 - 20 UNEF-2B	1.123	(28.5)	None		None	.125	(3.2)
111	1.000 - 20 UNEF-2B	1.188	(30.2)	.135	(3.4)	1	.125	(3.2)
112	1.125 - 20 UN-2B	1.312	(33.3)	None		None	.125	(3.2)
113	1.125 - 18 UNEF-2B	1.312	(33.3)	.135	(3.4)	1	.125	(3.2)
114	1.1875 - 18 UNEF-2B	1.375	(34.9)	None		None	.125	(3.2)
115	1.250 - 20 UN-2B	1.438	(36.5)	None		None	.125	(3.2)
116	1.250 - 18 UNEF-2B	1.438	(36.5)	.135	(3.4)	1	.125	(3.2)
117	1.375 - 18 UNEF-2B	1.562	(39.7)	.192	(4.9)	1	.125	(3.2)
118	1.4375 - 18 UNEF-2B	1.625	(41.3)	None		None	.125	(3.2)
119	1.500 - 20 UN-2B	1.688	(42.9)	None		None	.125	(3.2)
120	1.500 - 18 UNEF-2B	1.688	(42.9)	.192	(4.9)	1	.125	(3.2)
121	1.625 - 18 UNEF-2B	1.812	(46.0)	.192	(4.9)	1	.125	(3.2)
122	1.750 - 18 UNS-2B	2.000	(50.8)	.192	(4.9)	1	.125	(3.2)
123	1.875 - 16 UN-2B	2.125	(54.0)	None		None	.125	(3.2)
124	1.9375 - 16 UN-2B	2.187	(55.5)	None		None	.189	(4.8)
125	2.000 - 18 UNS-2B	2.250	(57.2)	None		None	.189	(4.8)
126	2.125 - 16 UN-2B	2.375	(60.3)	None		None	.189	(4.8)
127	2.250 - 16 UN-2B	2.500	(63.5)	None		None	.189	(4.8)
128	2.500 - 16 UN-2B	2.750	(69.9)	None		None	.189	(4.8)
129	2.750 - 16 UN-2B	3.000	(76.2)	None		None	.189	(4.8)
130	3.000 - 16 UN-2B	3.250	(82.6)	None		None	.189	(4.8)

1. For complete dimensions see applicable Military Specification.
2. Metric dimensions (mm) are indicated in parentheses.

MS3420 Telescoping Bushing

MS3420-3
Basic Part No. _____
Dash No. _____
Material is Rubber per
MIL-STD-417

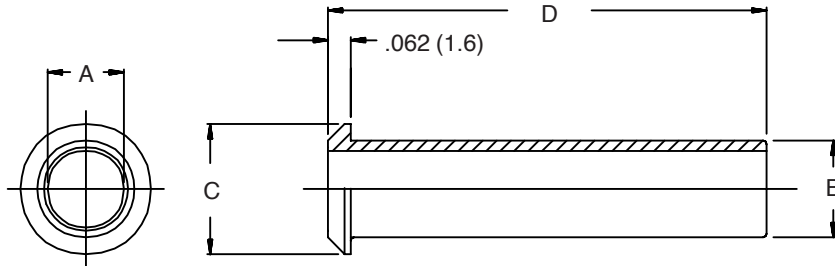

MS3420-3 L
Basic Part No. _____
Dash No. _____
Material _____
A = Rubber per MIL-STD-417
D = Silicone Rubber
L = Fluorosilicone Rubber

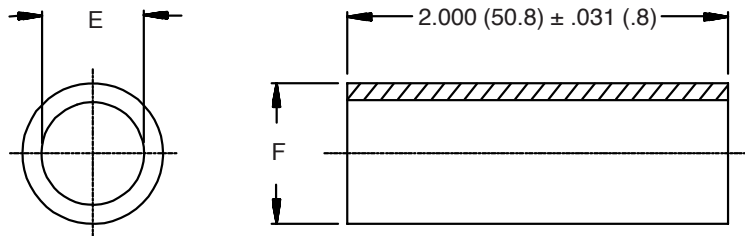

TABLE I

Dash No.	A Dia	B Dia	C Dia	D Dim	E Dia	F Dia
3	.130 (3.3)	.210 (5.3)	.379 (9.6)	2.875 (73.0)	.125 (3.2)	.210 (5.3)
4	.220 (5.6)	.302 (7.7)	.505 (12.8)	2.750 (69.9)	.219 (5.6)	.302 (7.7)
6	.312 (7.9)	.427 (10.8)	.619 (15.7)	2.625 (66.7)	.312 (7.9)	.427 (10.8)
8	.437 (11.1)	.552 (14.0)	.744 (18.9)	2.500 (63.5)	.438 (11.1)	.531 (13.5)
10	.562 (14.3)	.615 (15.6)	.889 (22.6)	2.375 (60.3)	.438 (11.1)	.615 (15.6)
12	.625 (15.9)	.740 (18.8)	1.084 (27.5)	2.250 (57.2)	.541 (13.7)	.740 (18.8)
16	.750 (19.1)	.927 (23.5)	1.314 (33.4)	2.125 (54.0)	.750 (19.1)	.927 (23.5)
18	n/a	n/a	n/a	n/a	.938 (23.8)	1.115 (28.3)
20	.937 (23.8)	1.240 (31.5)	1.598 (40.6)	2.000 (50.8)	.938 (23.8)	1.240 (31.5)
24	1.250 (31.8)	1.365 (34.7)	1.847 (46.9)	1.875 (47.6)	1.125 (28.6)	1.365 (34.7)
28	1.375 (34.9)	1.614 (41.0)	2.085 (53.0)	1.750 (44.5)	1.250 (31.8)	1.614 (41.0)
32	1.624 (41.2)	1.864 (47.3)	2.335 (59.3)	1.625 (41.3)	1.625 (41.3)	1.865 (47.4)
40	1.874 (47.6)	2.364 (60.0)	2.835 (72.0)	1.500 (38.1)	1.875 (47.6)	2.365 (60.1)

1. For complete dimensions see applicable Military Specification.
2. Metric dimensions (mm) are indicated in parentheses.

M28840/24 Gasket



Miscellaneous
Accessories

M28840/24 G A
 Basic Part No. ——— Material
 Designator ——— A = Fluorinated Silicone
 B = EMI Shielding - Rubber

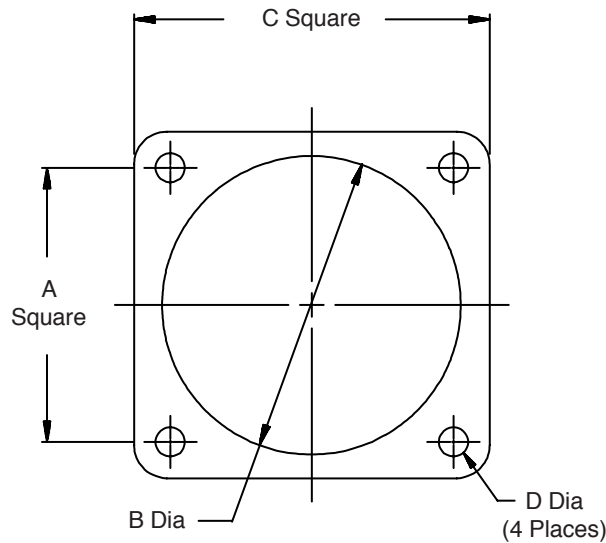

Designator	Shell Size	A Sq.		B Dia		C Sq.		D Dia	
		±.010	(.3)	±.008	(.2)	±.008	(.2)	±.010	(.3)
A	11	.750	(19.1)	.758	(19.3)	1.031	(26.2)	.120	(3.0)
B	13	.843	(21.4)	.883	(22.4)	1.146	(29.1)	.120	(3.0)
C	15	.968	(24.6)	1.070	(27.2)	1.266	(32.2)	.120	(3.0)
D	17	1.015	(25.8)	1.133	(28.8)	1.391	(35.3)	.120	(3.0)
E	19	1.140	(29.0)	1.320	(33.5)	1.516	(38.5)	.120	(3.0)
F	23	1.281	(32.5)	1.508	(38.3)	1.726	(43.8)	.120	(3.0)
G	25	1.392	(35.4)	1.633	(41.5)	1.826	(46.4)	.147	(3.7)
H	29	1.568	(39.8)	1.883	(47.8)	2.146	(54.5)	.147	(3.7)
J	33	1.734	(44.0)	2.070	(52.6)	2.336	(59.3)	.173	(4.4)

1. For complete dimensions see applicable Military Specification.
2. Metric dimensions (mm) are indicated in parentheses.

M29504/04 Size 16 Fiber Optic Pin Terminus

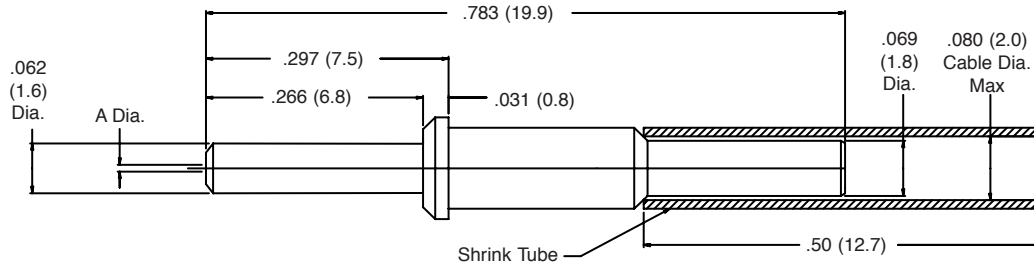
TABLE I

Part Number	Fiber Size Core/Cladding (Micron)	A Diameter (Microns)
M29504/04-4039	9/125 (Single Mode)	125
M29504/04-4040	50/125	126
M29504/04-4040	62.5/125	126
M29504/04-4042	100/140	142
M29504/04-4087	100/140/172 (Polyimide)	175

- Metric dimensions (mm) are in parentheses and are for reference only.
- Material/Finish:
 Ferrule - Zirconia Ceramic/N.A.
 Terminus Body - Stainless Steel/Passivate.
 Shrink Tube - Kynar/N.A.
- Recommended insertion/removal tool M81969/14-03.

M29504/05
Size 16 Fiber Optic
Socket Terminus



Miscellaneous
 Accessories

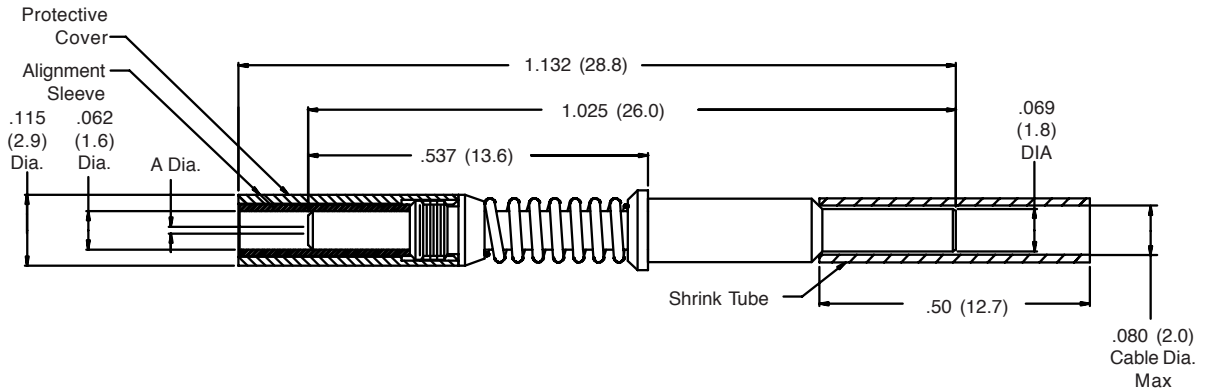

TABLE I

Part Number	Fiber Size Core/Cladding (Micron)	A Diameter (Microns)
M29504/05-4045	9/125 (Single Mode)	125
M29504/05-4046	50/125	126
M29504/05-4046	62.5/125	126
M29504/05-4049	100/140	142
M29504/05-4088	100/140/172 (Polyimide)	175

1. Metric dimensions (mm) are in parentheses and are for reference only.
2. Material/Finish:
 Ferrule and Alignment Sleeve: Zirconia Ceramic/N.A.
 Terminus Body: Stainless Steel/Passivate.
 Shrink Tube: Kynar/N.A.
3. Recommended insertion/removal tool M81969/14-03.

Glenair Connector
Designator H

MIL-DTL-38999
Series III & IV,
EN3645

D38999/28-11 F
Basic Part No. _____
Dash No. _____

Material and Finish:

C = Aluminum, Anodize

F = Aluminum, Electroless Nickel

K = Corrosion Resistant Steel Passivate

W = Aluminum, Cadmium Olive Drab over
Electroless Nickel

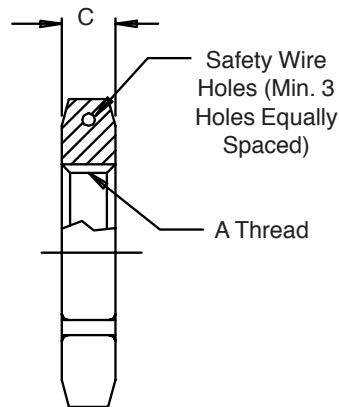
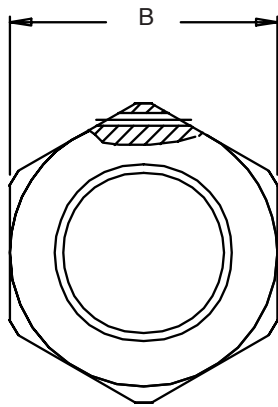

TABLE I

Dash No.	Shell Size		A Thread Class 2B	B Hex Max	C	
	Series III	Series IV			+0.018 -.000	(.45) (.00)
1	9	--	M17 X 1 - 6H*	.945 (24.00)	.125	(3.17)
2	11	--	M20 X 1 - 6H*	1.063 (27.00)	.125	(3.17)
3	13	11	M25 X 1 - 6H	1.260 (32.00)	.125	(3.17)
4	15	13	M28 X 1 - 6H	1.417 (36.00)	.125	(3.17)
5	--	15	M31 X 1 - 6H	1.614 (41.00)	.125	(3.17)
6	17	--	M32 X 1 - 6H	1.457 (37.00)	.125	(3.17)
7	--	17	M34 X 1 - 6H	1.614 (41.00)	.125	(3.17)
8	19	--	M35 X 1 - 6H	1.614 (41.00)	.125	(3.17)
9	21	19	M38 X 1 - 6H	1.811 (46.00)	.125	(3.17)
10	23	21	M41 X 1 - 6H	1.969 (50.00)	.125	(3.17)
11	25	23	M44 X 1 - 6H	2.017 (51.23)	.125	(3.17)
12	--	25	M47 X 1 - 6H	2.165 (55.00)	.125	(3.17)

* Modified Minor Diameter

1. For complete dimensions see applicable Military Specification.
2. Metric dimensions (mm) are indicated in parentheses.

M83723/70 Receptacle Adapter



Miscellaneous
Accessories

MIL-DTL-83723
Series III
Classes A, G, R and W

M83723/70 W 22

Basic Part No. _____ Dash No. _____

Material and Finish: _____

A = Aluminum, Black Anodize

R = Aluminum, Electroless Nickel

G = Corrosion Resistant Steel
Passivate

W = Aluminum, Cadmium Olive Drab over
Electroless Nickel

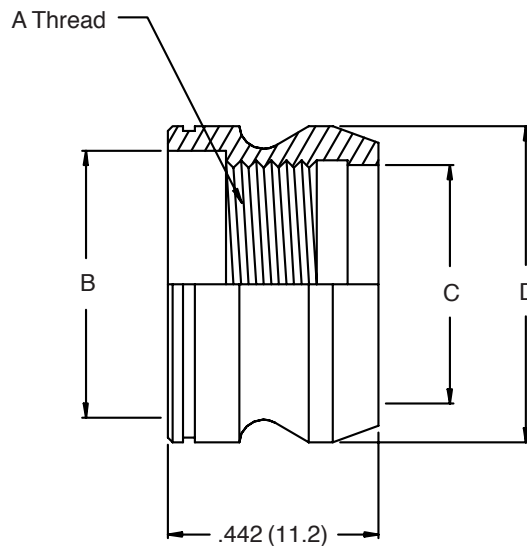

TABLE I

Shell Size	A Thread UNEF-2B	B Dia Max	C Dia	D Dia Max
8	.5264 - 24	.579 (14.7)	.525 (13.3)	.689 (17.5)
10	.6875 - 24	.714 (18.1)	.650 (16.5)	.814 (20.7)
12	.8750 - 20	.894 (22.7)	.840 (21.3)	1.001 (25.4)
14	.9375 - 20	.954 (24.2)	.900 (22.9)	1.064 (27.0)
16	1.0625 - 18	1.079 (27.4)	1.025 (26.0)	1.189 (30.2)
18	1.1875 - 18	1.204 (30.6)	1.150 (29.2)	1.330 (33.8)
20	1.3125 - 18	1.329 (33.8)	1.275 (32.4)	1.455 (37.0)
22	1.4375 - 18	1.454 (36.9)	1.400 (35.6)	1.580 (40.1)
24	1.5625 - 18	1.579 (40.1)	1.525 (38.7)	1.705 (43.3)

1. For complete dimensions see applicable Military Specification.
2. Metric dimensions (mm) are indicated in parentheses.

AS85049/32-1 90° Adapter, Non-Environmental, RFI

MIL-DTL-38999
Series I & II

M85049/32-1-8
Basic Part No. _____ Dash No. _____

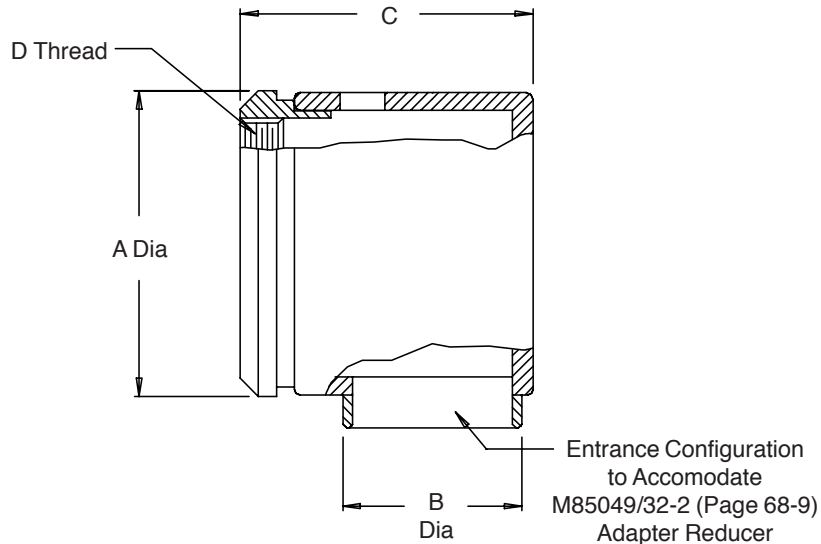

TABLE I

Dash No.	Shell Size		A Dia Max	B Dia Max	C Max	D Thread Class 2B
	Series I	Series II				
8	9	8	.594 (15.1)	.359 (9.1)	.719 (18.3)	.4375 - 28 UNEF
10	11	10	.719 (18.3)	.406 (10.3)	.766 (19.5)	.5625 - 24 UNEF
12	13	12	.844 (21.4)	.500 (12.7)	.859 (21.8)	.6875 - 24 UNEF
14	15	14	.969 (24.6)	.578 (14.7)	.938 (23.8)	.8125 - 20 UNEF
16	17	16	1.094 (27.8)	.641 (16.3)	1.000 (25.4)	.9375 - 20 UNEF
18	19	18	1.219 (31.0)	.688 (17.5)	1.047 (26.6)	1.0625 - 18 UNEF
20	21	20	1.344 (34.1)	.734 (18.6)	1.094 (27.8)	1.1875 - 18 UNEF
22	23	22	1.469 (37.3)	.796 (20.2)	1.156 (29.4)	1.3125 - 18 UNEF
24	25	24	1.594 (40.5)	.859 (21.8)	1.219 (31.0)	1.4375 - 18 UNEF

1. For complete dimensions see applicable Military Specification.
2. Metric dimensions (mm) are indicated in parentheses.
3. Material: Copper alloy. Finish: Tin-lead solder plate.

AS85049/32-2 Adapter Reducer



Miscellaneous
Accessories

MIL-DTL-38999
Series I & II

M85049/32-2-8
Basic Part No. _____ Dash No.

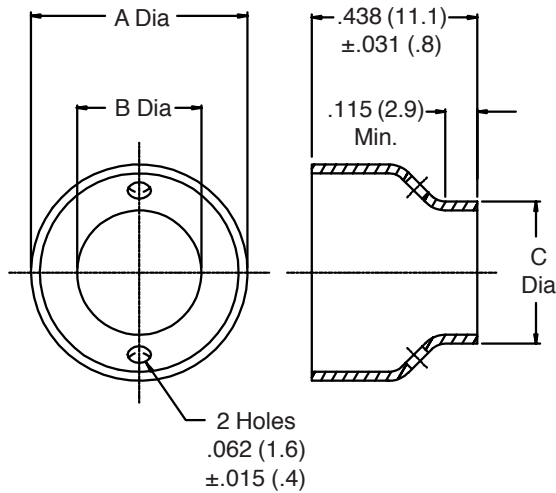

1. For complete dimensions see applicable Military Specification.
2. Metric dimensions (mm) are indicated in parentheses.
3. Material: Copper alloy. Finish: Tin-lead solder plate.
4. Adapter reducer for use with M85049/32-1 and M85049/33-1.

Dash No.	Fits Adapter Shell Size	A Dia Ref	B Dia Min	C Max
81	8	.291 (7.4)	.163 (4.1)	.219 (5.6)
82	8	.291 (7.4)	.171 (4.3)	.234 (5.9)
83	8	.291 (7.4)	.187 (4.7)	.250 (6.4)
101	10	.346 (8.8)	.216 (5.5)	.266 (6.8)
121	12	.441 (11.2)	.197 (5.0)	.250 (6.4)
122	12	.441 (11.2)	.216 (5.5)	.266 (6.8)
123	12	.441 (11.2)	.279 (7.1)	.328 (8.3)
141	14	.506 (12.9)	.216 (5.5)	.266 (6.8)
142	14	.506 (12.9)	.289 (7.3)	.344 (8.7)
143	14	.506 (12.9)	.311 (7.9)	.359 (9.1)
144	14	.506 (12.9)	.342 (8.7)	.391 (9.9)
145	14	.506 (12.9)	.359 (9.1)	.406 (10.3)
146	14	.571 (14.5)	.386 (9.8)	.438 (11.1)
161	16	.571 (14.5)	.216 (5.5)	.266 (6.8)
162	16	.571 (14.5)	.289 (7.3)	.344 (8.7)
163	16	.571 (14.5)	.342 (8.7)	.391 (9.9)
164	16	.571 (14.5)	.405 (10.3)	.453 (11.5)
165	16	.571 (14.5)	.327 (8.3)	.375 (9.5)
181	18	.616 (15.6)	.216 (5.5)	.266 (6.8)
182	18	.616 (15.6)	.289 (7.3)	.344 (8.7)
183	18	.616 (15.6)	.342 (8.7)	.391 (9.9)
184	18	.616 (15.6)	.380 (9.7)	.430 (10.9)
185	18	.616 (15.6)	.450 (11.4)	.500 (12.7)
201	20	.664 (16.9)	.327 (8.3)	.375 (9.5)
202	20	.664 (16.9)	.390 (9.9)	.453 (11.5)
203	20	.664 (16.9)	.444 (11.3)	.500 (12.7)
204	20	.664 (16.9)	.405 (10.3)	.469 (11.9)
205	20	.664 (16.9)	.483 (12.3)	.531 (13.5)
206	20	.664 (16.9)	.499 (12.7)	.547 (13.9)
221	22	.738 (18.7)	.358 (9.1)	.406 (10.3)
222	22	.738 (18.7)	.437 (11.1)	.484 (12.3)
223	22	.738 (18.7)	.452 (11.5)	.500 (12.7)
224	22	.738 (18.7)	.468 (11.9)	.516 (13.1)
225	22	.738 (18.7)	.561 (14.2)	.609 (15.5)
241	24	.796 (20.2)	.593 (15.1)	.641 (16.3)

AS85049/33-1 Adapter, Non-Environmental, RFI

MIL-DTL-38999
Series I & II

M85049/33-1-8
Basic Part No. _____ Dash No. _____

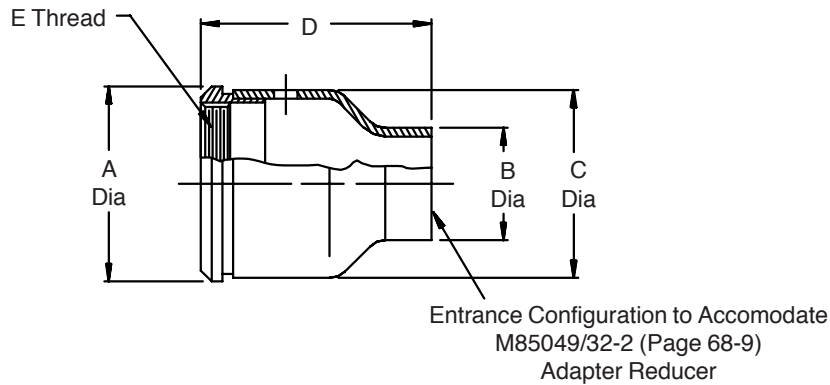

TABLE I

Dash No.	Shell Size		A Dia Max	B Dia Max	C Dia Max	D Max	E Thread Class 2B
	Series I	Series II					
8	9	8	.594 (15.1)	.359 (9.1)	.516 (13.1)	.844 (21.4)	.4375 - 28 UNEF
10	11	10	.719 (18.3)	.406 (10.3)	.641 (16.3)	.969 (24.6)	.5625 - 24 UNEF
12	13	12	.844 (21.4)	.500 (12.7)	.766 (19.5)	1.094 (27.8)	.6875 - 24 UNEF
14	15	14	.969 (24.6)	.578 (14.7)	.891 (22.6)	1.156 (29.4)	.8125 - 20 UNEF
16	17	16	1.094 (27.8)	.641 (16.3)	1.016 (25.8)	1.219 (31.0)	.9375 - 20 UNEF
18	19	18	1.219 (31.0)	.688 (17.5)	1.141 (29.0)	1.344 (34.1)	1.0625 - 18 UNEF
20	21	20	1.344 (34.1)	.734 (18.6)	1.265 (32.1)	1.469 (37.3)	1.1875 - 18 UNEF
22	23	22	1.469 (37.3)	.796 (20.2)	1.391 (35.3)	1.594 (40.5)	1.3125 - 18 UNEF
24	25	24	1.594 (40.5)	.859 (21.8)	1.516 (38.5)	1.719 (43.7)	1.4375 - 18 UNEF

1. For complete dimensions see applicable Military Specification.
2. Metric dimensions (mm) are indicated in parentheses.
3. Material: Copper alloy. Finish: Tin-lead solder plate.

M85049/74 Potting Boot



Miscellaneous
Accessories

For Use With M85049/61
Potting Boot Ring
(Page 30-3)

M85049/74-10-1
Basic Part No. _____ Geometry
Shell Size _____ 1 = Straight
2 = 90°

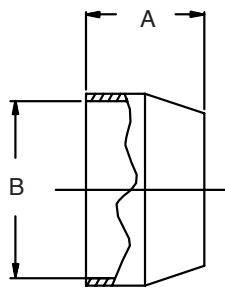

Straight Boot

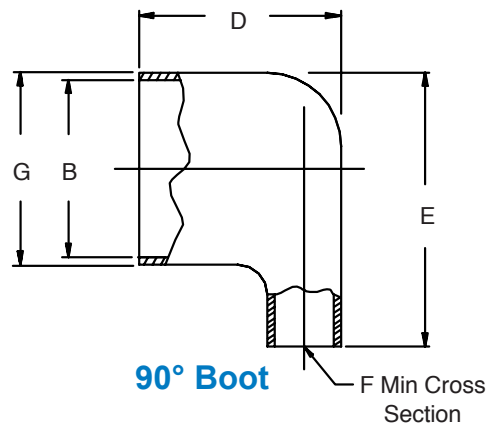
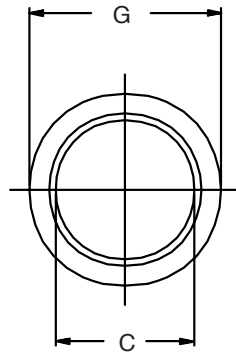

90° Boot

TABLE I

Shell Size	A Min	A Max	B Dia ±.005 (.1)	C Min ID	D Max	E Max	F Min	G Max
8	.450 (11.4)	.500 (12.7)	.511 (13.0)	.317 (8.1)	.766 (19.5)	1.000 (25.4)	.110 (2.8)	.608 (15.4)
10	.450 (11.4)	.500 (12.7)	.637 (16.2)	.434 (11.0)	.922 (23.4)	1.125 (28.6)	.200 (5.1)	.734 (18.6)
12	.450 (11.4)	.500 (12.7)	.761 (19.3)	.548 (13.9)	1.031 (26.2)	1.125 (28.6)	.290 (7.4)	.858 (21.8)
14	.450 (11.4)	.500 (12.7)	.887 (22.5)	.673 (17.1)	1.016 (25.8)	1.297 (32.9)	.400 (10.2)	.984 (25.0)
16	.450 (11.4)	.500 (12.7)	1.013 (25.7)	.798 (20.3)	1.016 (25.8)	1.375 (34.9)	.490 (12.4)	1.110 (28.2)
18	.450 (11.4)	.500 (12.7)	1.137 (28.9)	.899 (22.8)	1.078 (27.4)	1.469 (37.3)	.590 (15.0)	1.234 (31.3)
20	.550 (14.0)	.594 (15.1)	1.263 (32.1)	1.024 (26.0)	1.094 (27.8)	1.625 (41.3)	.730 (18.5)	1.360 (34.5)
22	.550 (14.0)	.594 (15.1)	1.387 (35.2)	1.149 (29.2)	1.094 (27.8)	1.703 (43.3)	.860 (21.8)	1.484 (37.7)
24	.550 (14.0)	.594 (15.1)	1.513 (38.4)	1.274 (32.4)	1.281 (32.5)	2.047 (52.0)	1.070 (27.2)	1.610 (40.9)

1. For complete dimensions see applicable Military Specification.
2. Metric dimensions (mm) are indicated in parentheses.
3. Material: Translucent nylon, minimum wall thickness .020 (.51).

AS85049/75 Potting Boot

For Use With M85049/58
Potting Boot Ring
(Page 30-2)

M85049/75-10-1
Basic Part No. _____ Geometry
Shell Size _____ 1 = Straight
2 = 90°

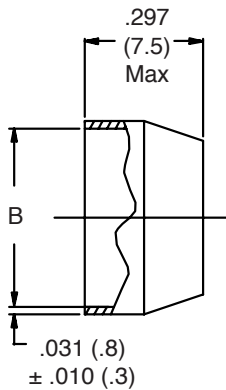

Straight Boot

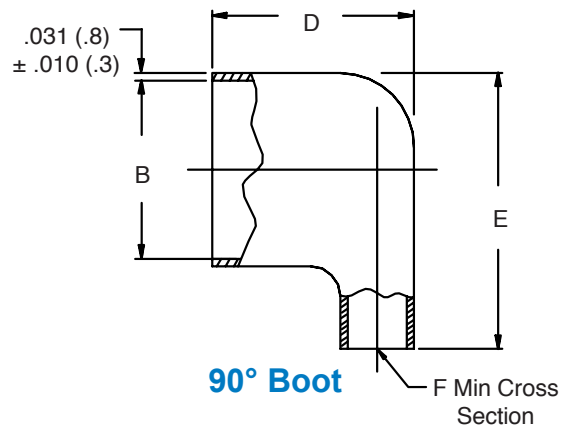
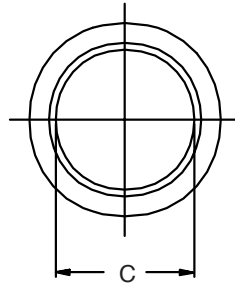

90° Boot

TABLE I

Shell Size	B Dia ±.005 (.1)	C Min ID	D Max	E Max	F Min
8	.527 (13.4)	.434 (11.0)	.438 (11.1)	.766 (19.5)	.073 (1.9)
10	.652 (16.6)	.548 (13.9)	.469 (11.9)	.891 (22.6)	.117 (3.0)
12	.776 (19.7)	.673 (17.1)	.562 (14.3)	1.031 (26.2)	.206 (5.2)
14	.898 (22.8)	.798 (20.3)	.719 (18.3)	1.156 (29.4)	.384 (9.8)
16	1.016 (25.8)	.899 (22.8)	.781 (19.8)	1.287 (32.7)	.443 (11.3)
18	1.140 (29.0)	1.024 (26.0)	.844 (21.4)	1.406 (35.7)	.561 (14.2)
20	1.265 (32.1)	1.149 (29.2)	.906 (23.0)	1.531 (38.9)	.693 (17.6)
22	1.390 (35.3)	1.274 (32.4)	.938 (23.8)	1.656 (42.1)	.840 (21.3)
24	1.515 (38.5)	1.399 (35.5)	1.031 (26.2)	1.781 (45.2)	.999 (25.4)

1. For complete dimensions see applicable Military Specification.
2. Metric dimensions (mm) are indicated in parentheses.
3. Material: Translucent nylon.

AS85049/93 Banding Split-Ring



Miscellaneous
Accessories

Basic Part No. **M85049/93-10** Dash No.

1. For complete dimensions see applicable Military Specification.
2. Metric dimensions (mm) are indicated in parentheses.
3. Use with Glenair banding backshells and braid socks. Consult factory for specific application part numbers.

Dash No.	A Dia		B Dia	
	± .01	(0.3)	± .03	(0.8)
04	.25	(6.4)	.36	(9.1)
06	.38	(9.7)	.49	(12.4)
08	.50	(12.7)	.61	(15.5)
10	.63	(16.0)	.74	(18.8)
12	.75	(19.1)	.86	(21.8)
14	.88	(22.4)	.99	(25.1)
16	1.00	(25.4)	1.11	(28.2)
18	1.13	(28.7)	1.24	(31.5)
20	1.25	(31.8)	1.36	(34.5)
22	1.38	(35.1)	1.49	(37.8)
24	1.50	(38.1)	1.61	(40.9)
26	1.63	(41.4)	1.74	(44.2)
28	1.75	(44.5)	1.86	(47.2)

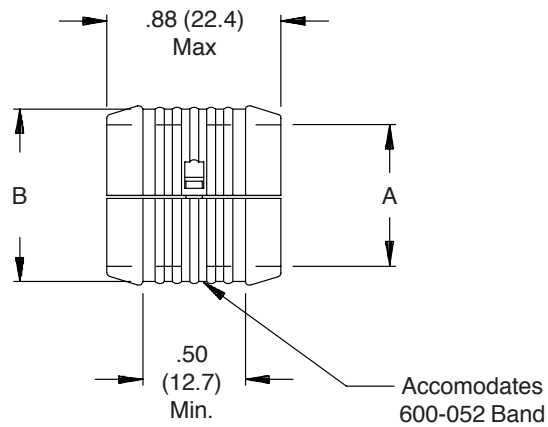
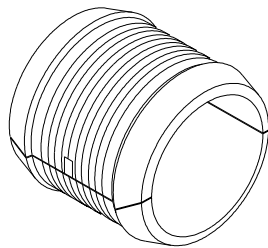

SAMPLE APPLICATION

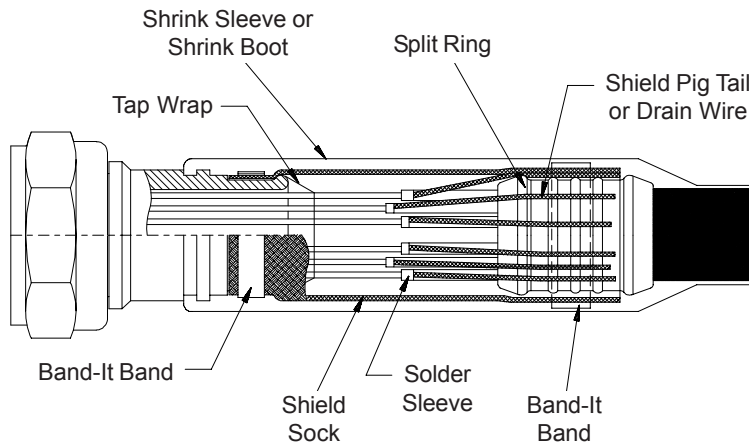

AS85049/94 Mounting Flange, Full Perimeter

M85049/94-10-A

Basic Part No.

Shell Size

A = Primer Coat
Required

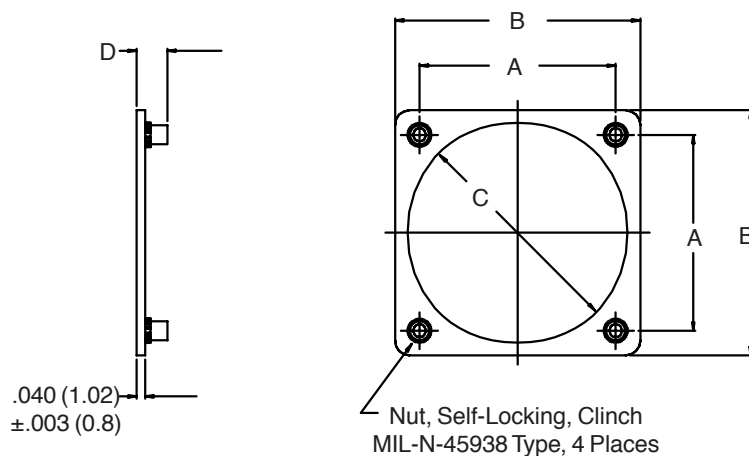

TABLE I

Shell Size	Thread UNJC-3B	A		B		C		D
		±.015	(0.38)	Max		±.015	(.4)	
8	4-40	.594	(15.1)	.980	(24.9)	.570	(14.5)	.106 (.166)
10	4-40	.719	(18.3)	1.034	(26.3)	.720	(18.3)	.106 (.166)
12	4-40	.812	(20.6)	1.119	(28.4)	.855	(21.7)	.106 (.166)
14	4-40	.906	(23.0)	1.213	(30.8)	.984	(25.0)	.106 (.166)
16	4-40	.969	(24.6)	1.295	(32.9)	1.094	(27.8)	.106 (.166)
18	4-40	1.062	(27.0)	1.421	(36.1)	1.220	(31.0)	.106 (.166)
20	4-40	1.156	(29.4)	1.550	(39.4)	1.345	(34.2)	.106 (.166)
22	4-40	1.250	(31.8)	1.680	(42.7)	1.478	(37.5)	.106 (.166)
24	6-32	1.375	(34.9)	1.800	(45.7)	1.595	(40.5)	.123 (.183)
25	6-32	1.500	(38.1)	1.910	(48.5)	1.658	(42.1)	.123 (.183)

1. For complete dimensions see applicable Military Specification.
2. Metric dimensions (mm) are indicated in parentheses.

AS85049/95 Mounting Flange, 3/4 Perimeter



M85049/95-10A-A

Basic Part No. _____ A = Primer Coat Required
Shell Size and Class _____

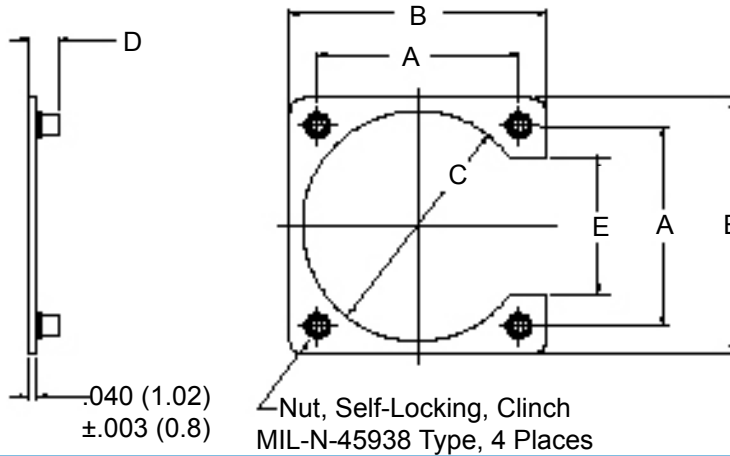

1. For complete dimensions see applicable Military Specification.
2. Metric dimensions (mm) are indicated in parentheses.

TABLE I

Shell Size & Class	Thread UNJC-3B	A		B		C		D		E	
		±.003 (.1)	(.1)	±.015 (.4)	(.4)	+0.015 (-0.000) (.0)	(.0)	±.030 (.8)	(.8)	±.030 (.76)	(.76)
3A	4-40	.625	(15.9)	.925	(23.5)	.641	(16.3)	.136	(3.5)	.325	(8.3)
7A	4-40	.719	(18.3)	1.019	(25.9)	.688	(17.5)	.136	(3.5)	.433	(11.0)
8A	4-40	.594	(15.1)	.880	(22.4)	.570	(14.5)	.136	(3.5)	.308	(7.8)
10A	4-40	.719	(18.3)	1.019	(25.9)	.720	(18.3)	.136	(3.5)	.433	(11.0)
10B	6-32	.812	(20.6)	1.312	(33.3)	.749	(19.0)	.153	(3.9)	.433	(11.0)
12A	4-40	.812	(20.6)	1.104	(28.0)	.855	(21.7)	.136	(3.5)	.530	(13.5)
12B	6-32	.938	(23.8)	1.312	(33.3)	.938	(23.8)	.153	(3.9)	.526	(13.4)
14A	4-40	.906	(23.0)	1.198	(30.4)	.984	(25.0)	.136	(3.5)	.624	(15.8)
14B	6-32	1.031	(26.2)	1.406	(35.7)	1.031	(26.2)	.153	(3.9)	.620	(15.7)
16A	4-40	.969	(24.6)	1.280	(32.5)	1.094	(27.8)	.136	(3.5)	.687	(17.4)
16B	6-32	1.125	(28.6)	1.500	(38.1)	1.125	(28.6)	.153	(3.9)	.683	(17.3)
18A	4-40	1.062	(27.0)	1.406	(35.7)	1.220	(31.0)	.136	(3.5)	.780	(19.8)
18B	6-32	1.203	(30.6)	1.578	(40.1)	1.234	(31.3)	.153	(3.9)	.776	(19.7)
19A	4-40	.906	(23.0)	1.192	(30.3)	.953	(24.2)	.136	(3.5)	.620	(15.7)
20A	4-40	1.156	(29.4)	1.535	(39.0)	1.345	(34.2)	.136	(3.5)	.874	(22.2)
20B	6-32	1.297	(32.9)	1.688	(42.9)	1.359	(34.5)	.153	(3.9)	.865	(22.0)
22A	4-40	1.250	(31.8)	1.665	(42.3)	1.478	(37.5)	.136	(3.5)	.968	(24.6)
22B	6-32	1.375	(34.9)	1.738	(44.1)	1.483	(37.7)	.153	(3.9)	.907	(23.0)
24A	6-32	1.500	(38.1)	1.891	(48.0)	1.560	(39.6)	.153	(3.9)	1.000	(25.4)
24B	6-32	1.375	(34.9)	1.785	(45.3)	1.595	(40.5)	.153	(3.9)	1.031	(26.2)
25A	6-32	1.500	(38.1)	1.891	(48.0)	1.658	(42.1)	.153	(3.9)	1.125	(28.6)
27A	4-40	.969	(24.6)	1.255	(31.9)	1.094	(27.8)	.136	(3.5)	.683	(17.3)
28A	6-32	1.562	(39.7)	2.000	(50.8)	1.820	(46.2)	.153	(3.9)	1.125	(28.6)
32A	6-32	1.750	(44.5)	2.312	(58.7)	2.062	(52.4)	.153	(3.9)	1.188	(30.2)
36A	6-32	1.938	(49.2)	2.500	(63.5)	2.312	(58.7)	.153	(3.9)	1.375	(34.9)
37A	4-40	1.187	(30.1)	1.500	(38.1)	1.281	(32.5)	.136	(3.5)	.874	(22.2)
61A	4-40	1.437	(36.5)	1.812	(46.0)	1.594	(40.5)	.136	(3.5)	1.602	(40.7)

AS85049/96 and M85528/3 Mounting Flange, 1/4 Perimeter

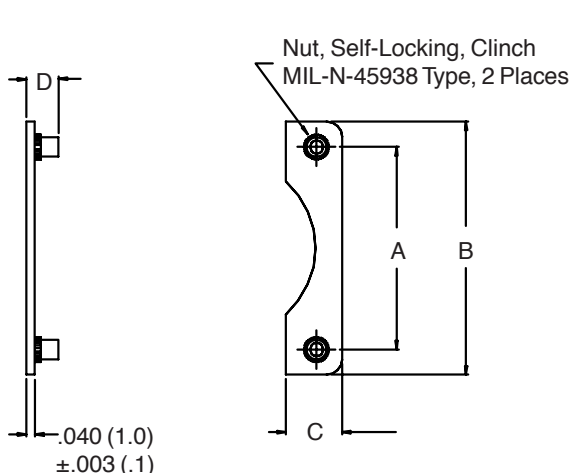

M85049/96-10-A
Basic Part No. _____
Shell Size _____
A = Primer Coat Required _____

M85528/3-10-01
Basic Part No. _____
Shell Size _____
Numerical designation 01
indicates corrosion resistant
nuts are required. Omit for
alloy steel nuts.

TABLE I

Shell Size	Thread UNJC-3B	A		B		C		D	
		±.003 (.1)	(.1)	±.015 (.4)	(.4)	+0.010 (.3) -0.000 (.0)	(.3)	±.030 (.8)	(.8)
3	4-40	.625	(15.9)	.925	(23.5)	.300	(7.6)	.136	(3.5)
6*	4-40	.469	(11.9)	.766	(19.5)	.298	(7.6)	.136	(3.5)
7	4-40	.719	(18.3)	1.016	(25.8)	.298	(7.6)	.136	(3.5)
8	4-40	.594	(15.1)	.891	(22.6)	.296	(7.5)	.136	(3.5)
10	4-40	.719	(18.3)	1.016	(25.8)	.298	(7.6)	.136	(3.5)
12	4-40	.812	(20.6)	1.109	(28.2)	.296	(7.5)	.136	(3.5)
14	4-40	.906	(23.0)	1.203	(30.6)	.296	(7.5)	.136	(3.5)
16	4-40	.969	(24.6)	1.266	(32.2)	.298	(7.6)	.136	(3.5)
18	4-40	1.062	(27.0)	1.390	(35.3)	.328	(8.3)	.136	(3.5)
19	4-40	.906	(23.0)	1.203	(30.6)	.296	(7.5)	.136	(3.5)
20	4-40	1.156	(29.4)	1.510	(38.4)	.354	(9.0)	.136	(3.5)
22	4-40	1.250	(31.8)	1.640	(41.7)	.390	(9.9)	.136	(3.5)
24	6-32	1.375	(34.9)	1.760	(44.7)	.386	(9.8)	.153	(3.9)
25	6-32	1.500	(38.1)	1.859	(47.2)	.358	(9.1)	.153	(3.9)
27	4-40	.969	(24.6)	1.266	(32.2)	.298	(7.6)	.136	(3.5)
28	6-32	1.562	(39.7)	2.000	(50.8)	.438	(11.1)	.153	(3.9)
32	6-32	1.750	(44.5)	2.312	(58.7)	.562	(14.3)	.153	(3.9)
36	6-32	1.938	(49.2)	2.500	(63.5)	.562	(14.3)	.153	(3.9)
37	4-40	1.187	(30.1)	1.500	(38.1)	.314	(8.0)	.136	(3.5)
61	4-40	1.437	(36.5)	1.812	(46.0)	.376	(9.6)	.136	(3.5)

* Shell Size 6 - Available in M85528/3 only.

1. For complete dimensions see applicable Military Specification.
2. Metric dimensions (mm) are indicated in parentheses.

M85528/1 Mounting Flange, Full Perimeter



Miscellaneous
Accessories

M85528/1-10 A
 Basic Part No. _____
 Shell Size _____
 A = Primer Coat Required

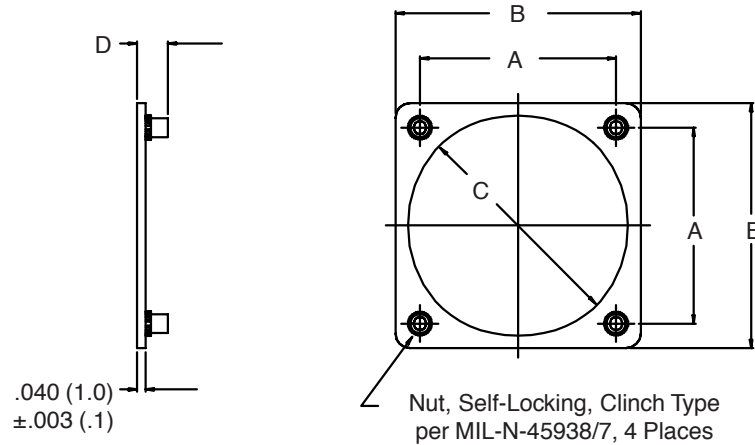

Shell Size	Thread UNJC-3B	A		B		C		D	
		±.003 (.1)	(.1)	±.015 (.4)	(.4)	-.010 (.3)	(.3)	±.030 (.8)	(.8)
8	4-40	.594	(15.1)	.880	(22.4)	.570	(14.5)	.136	(3.5)
10	4-40	.719	(18.3)	1.005	(25.5)	.700	(17.8)	.136	(3.5)
12	4-40	.812	(20.6)	1.098	(27.9)	.820	(20.8)	.136	(3.5)
14	4-40	.906	(23.0)	1.192	(30.3)	.945	(24.0)	.136	(3.5)
16	4-40	.969	(24.6)	1.255	(31.9)	1.070	(27.2)	.136	(3.5)
18	4-40	1.062	(27.0)	1.348	(34.2)	1.196	(30.4)	.136	(3.5)
20	4-40	1.156	(29.4)	1.500	(38.1)	1.320	(33.5)	.136	(3.5)
22	4-40	1.250	(31.8)	1.625	(41.3)	1.440	(36.6)	.136	(3.5)
24	6-32	1.375	(34.9)	1.750	(44.5)	1.570	(39.9)	.153	(3.9)
25	6-32	1.500	(38.1)	1.891	(48.0)	1.658	(42.1)	.153	(3.9)

1. For complete dimensions see applicable Military Specification.
2. Metric dimensions (mm) are indicated in parentheses.

M85528/2 Mounting Flange, 3/4 Perimeter

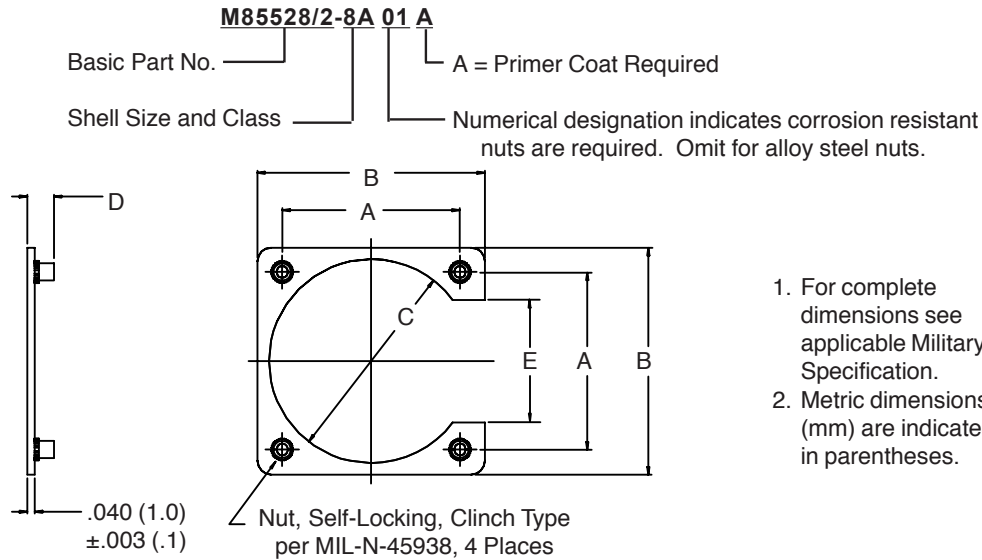

1. For complete dimensions see applicable Military Specification.
2. Metric dimensions (mm) are indicated in parentheses.

TABLE I

Shell Size & Class	Thread UNJC-3B	A		B		C		D		E	
		±.003 (.1)	±.015 (.4)	±.010 (.4)	±.030 (.8)	±.020 (.5)					
3A	4-40	.625 (15.9)	.925 (23.5)	.641 (16.3)	.136 (3.5)	.325 (8.3)					
6A	4-40	.469 (11.9)	.755 (19.2)	.366 (9.3)	.136 (3.5)	.183 (4.6)					
7A	4-40	.719 (18.3)	1.019 (25.9)	.688 (17.5)	.136 (3.5)	.433 (11.0)					
8A	4-40	.594 (15.1)	.880 (22.4)	.570 (14.5)	.136 (3.5)	.308 (7.8)					
10A	4-40	.719 (18.3)	1.019 (25.9)	.720 (18.3)	.136 (3.5)	.433 (11.0)					
10B	6-32	.812 (20.6)	1.187 (30.1)	.749 (19.0)	.153 (3.9)	.433 (11.0)					
12A	4-40	.812 (20.6)	1.104 (28.0)	.855 (21.7)	.136 (3.5)	.530 (13.5)					
12B	6-32	.938 (23.8)	1.312 (33.3)	.938 (23.8)	.153 (3.9)	.526 (13.4)					
14A	4-40	.906 (23.0)	1.198 (30.4)	.984 (25.0)	.136 (3.5)	.624 (15.8)					
14B	6-32	1.031 (26.2)	1.406 (35.7)	1.031 (26.2)	.153 (3.9)	.620 (15.7)					
16A	4-40	.969 (24.6)	1.280 (32.5)	1.094 (27.8)	.136 (3.5)	.687 (17.4)					
16B	6-32	1.125 (28.6)	1.500 (38.1)	1.125 (28.6)	.153 (3.9)	.683 (17.3)					
18A	4-40	1.062 (27.0)	1.406 (35.7)	1.220 (31.0)	.136 (3.5)	.780 (19.8)					
18B	6-32	1.203 (30.6)	1.578 (40.1)	1.234 (31.3)	.153 (3.9)	.776 (19.7)					
19A	4-40	.906 (23.0)	1.192 (30.3)	.953 (24.2)	.136 (3.5)	.620 (15.7)					
20A	4-40	1.156 (29.4)	1.535 (39.0)	1.345 (34.2)	.136 (3.5)	.874 (22.2)					
20B	6-32	1.297 (32.9)	1.688 (42.9)	1.359 (34.5)	.153 (3.9)	.865 (22.0)					
22A	4-40	1.250 (31.8)	1.665 (42.3)	1.478 (37.5)	.136 (3.5)	.968 (24.6)					
22B	6-32	1.375 (34.9)	1.738 (44.1)	1.483 (37.7)	.153 (3.9)	.907 (23.0)					
24A	4-40	1.500 (38.1)	1.891 (48.0)	1.560 (39.6)	.153 (3.9)	1.000 (25.4)					
24B	6-32	1.375 (34.9)	1.785 (45.3)	1.595 (40.5)	.153 (3.9)	1.031 (26.2)					
25A	6-32	1.500 (38.1)	1.891 (48.0)	1.658 (42.1)	.153 (3.9)	1.125 (28.6)					
27A	4-40	.969 (24.6)	1.255 (31.9)	1.094 (27.8)	.136 (3.5)	.683 (17.3)					
28A	6-32	1.562 (39.7)	2.000 (50.8)	1.820 (46.2)	.153 (3.9)	1.125 (28.6)					
32A	6-32	1.750 (44.5)	2.312 (58.7)	2.062 (52.4)	.153 (3.9)	1.188 (30.2)					
36A	6-32	1.938 (49.2)	2.500 (63.5)	2.312 (58.7)	.153 (3.9)	1.375 (34.9)					
37A	4-40	1.187 (30.1)	1.500 (38.1)	1.281 (32.5)	.136 (3.5)	.874 (22.2)					
61A	4-40	1.437 (36.5)	1.812 (46.0)	1.594 (40.5)	.136 (3.5)	1.602 (40.7)					

M24758 Flexible Waterproof EMI/EMP Conduit and Associated End Fittings



Conduit & Accessories



Glenair's M24758 Series conduit and associated fittings have been tested and qualified in accordance with MIL-C-24758 (SH). Glenair's M24758 products are designed to shield cables from electromagnetic radiation, electromagnetic pulse, and to provide weatherproofing. Glenair's M24758 Series products offer the highest level of performance and quality while providing a field-installable and cost-effective conduit system.

Glenair uniquely offers three types of conduit conforming to MIL-C-24758 (SH): For superior shielding performance and crush resistance, Glenair's standard M24758/1 conduit offers a brass inner core with a bronze overbraid, sealed from the weather by a neoprene outer jacket. The brass conduit may also be ordered with a compressed inner core for increased flexibility.

For applications where crush resistance is not required, Glenair offers a fluorocarbon (FEP) inner core with two tin over copper braids and a neoprene outer jacket.

MIL-C-24758 specifies the following platings for fitting materials: CRES-Passivate; Aluminum-Cadmium over Electroless Nickel; Brass-no plating.

Glenair continues to design and manufacture many additional MIL-C-24758 style products to meet specific customer and industry needs. Other Glenair conduit products include: Series 75 Flexible Metal Core Conduit (IAW MIL-C-13909/A-A-52240), MIL-C-28840 Conduit and Fittings, and NAVSEA RP2000 and GR2000 series fitting. Please consult the factory if you have applications not covered by this catalog product offering.

Military Specification	Description	Page
GP2000	NAVSEA Series GP2000 Fittings	71-41
M24758/1	Flexible Weatherproof EMI-EMP Conduit	71-2
M24758/2	Straight Conduit Fitting for M24758/9 thru /19	71-3
M24758/3	45° Conduit Fitting for M24758/9 thru /19	71-4
M24758/4	90° Conduit Fitting for M24758/9 thru /19	71-5
M24758/5	Conduit-to-Panel Fitting	71-6
M24758/6	Conduit-to-Threaded Pipe Fitting	71-7
M24758/7	Conduit-to-Stuffing Tube	71-8
M24758/8	Conduit-to-Conduit Fitting	71-11
M24758/9	Adapter for MIL-DTL-5015 Connectors (MS3100 Series)	71-12
M24758/10	Adapter for Triaxial Connectors	71-14
M24758/11	Adapter for Coaxial Connectors	71-16
M24758/12	Adapter for MIL-DTL-26482 Series I Connectors	71-18
M24758/13	Adapter for MS3155-type Connectors	71-20
M24758/14	Adapter for MIL-C-28840-type Connectors	71-22
M24758/15	Adapter for MS24235 Stuffing Tube	71-24
M24758/16	Adapter for Miscellaneous Thread	71-26
M24758/17	Adapter for Tapered Pipe Thread	71-28
M24758/18	Adapter for Straight Pipe Thread	71-29
M24758/19	Adapter for Panel Termination	71-30
M28840/4	Flexible Metal Core Conduit	71-31
M28840/5	EMI/EMP Conduit Backshell	71-32
M28840/22	Conduit Bushing	71-35
M28840/25	90° EMI Adapters for M28840 Connectors	71-36
M28840/27	45° EMI Adapters for M28840 Connectors	71-38
M28840/30	Conduit Union	71-40
RP2000	NAVSEA Series RP2000 Fittings	71-41

M24758/1-16

Basic Part No. _____ Conduit Size Code _____

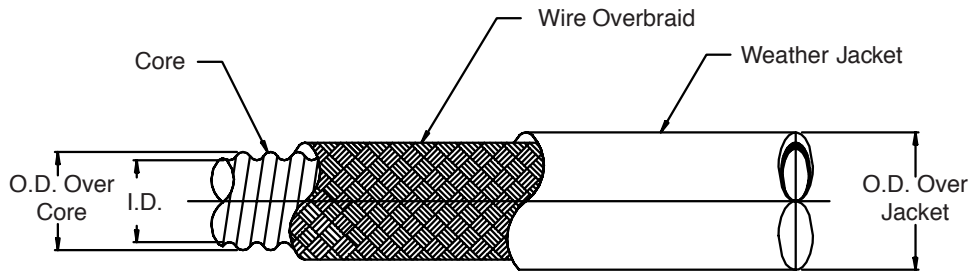

TABLE I

Conduit Size Code	Nominal I.D.	I.D. Min	O.D. (Over Core)		O.D. (Over Jacket)		Min Bend Radius (Inside)
			± 0.01	(.3)	$\pm .040$	(1.0)	
02	.250 (6.4)	.245 (6.2)	.364 (9.2)	.580 (14.7)	1.250 (31.8)		
03	.375 (9.5)	.370 (9.4)	.488 (12.4)	.700 (17.8)	2.000 (50.8)		
04	.500 (12.7)	.495 (12.6)	.637 (16.2)	.850 (21.6)	2.500 (63.5)		
05	.625 (15.9)	.620 (15.7)	.760 (19.3)	.980 (24.9)	3.000 (76.2)		
06	.750 (19.1)	.745 (18.9)	.880 (22.4)	1.100 (27.9)	3.750 (95.3)		
08	1.000 (25.4)	.995 (25.3)	1.192 (30.3)	1.410 (35.8)	5.000 (127.0)		
10	1.250 (31.8)	1.245 (31.6)	1.454 (36.9)	1.660 (42.2)	6.250 (158.8)		
12	1.500 (38.1)	1.495 (38.0)	1.704 (43.3)	1.910 (48.5)	7.500 (190.5)		
16	2.000 (50.8)	1.995 (50.7)	2.214 (56.2)	2.440 (62.0)	10.000 (254.0)		
20	2.500 (63.5)	2.495 (63.4)	2.714 (68.9)	2.940 (74.7)	12.500 (317.5)		
24	3.000 (76.2)	2.995 (76.1)	3.204 (81.4)	3.440 (87.4)	15.000 (381.0)		

1. Metric dimensions (mm) are indicated in parentheses.
2. For complete dimensions see applicable Military Specification.

M24758/2 Straight Conduit Fitting



Conduit & Accessories

M24758/2-16-A

Basic Part No. ————
 Conduit Size Code ————

Material Designator:
 A = Aluminum
 B = Brass
 C = CRES 316

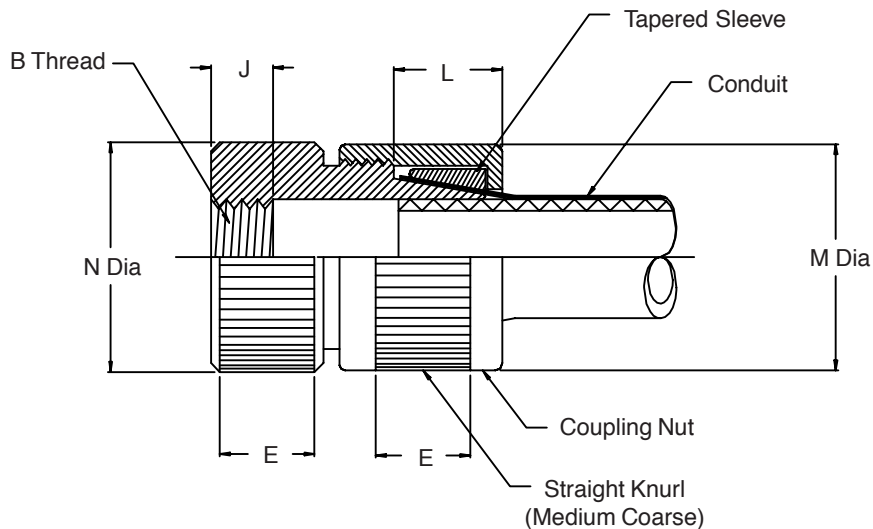

TABLE I

Conduit Size Code	B THREAD (Class 2B)	E KNURL LENGTH		J THREAD LENGTH		L CONE LENGTH		M DIA (Maximum)	N DIA (Maximum)
		±.06 (15.2)	(15.2)	+06 (15.2)	-0 (15.2)	±.06 (15.2)	(15.2)		
02	0.438 - 28 UNEF	.500 (12.7)	.210 (5.3)	.750 (19.1)	.930 (23.6)	.700 (17.8)			
03	0.563 - 24 UNEF	.500 (12.7)	.250 (6.4)	.750 (19.1)	1.120 (28.4)	.820 (20.8)			
04	0.688 - 24 UNEF	.620 (15.7)	.250 (6.4)	.750 (19.1)	1.250 (31.8)	.970 (24.6)			
05	0.813 - 20 UNEF	.620 (15.7)	.310 (7.9)	.750 (19.1)	1.430 (36.3)	1.120 (28.4)			
06	0.938 - 20 UNEF	.750 (19.1)	.310 (7.9)	.750 (19.1)	1.620 (41.1)	1.220 (31.0)			
08	1.250 - 18 UNEF	.750 (19.1)	.370 (9.4)	1.000 (25.4)	1.810 (46.0)	1.530 (38.9)			
10	1.563 - 18 UNEF	.870 (22.1)	.370 (9.4)	1.000 (25.4)	2.180 (55.4)	1.810 (46.0)			
12	1.875 - 16 UN	.870 (22.1)	.430 (10.9)	1.000 (25.4)	2.560 (65.0)	2.120 (53.8)			
16	2.375 - 16 UN	1.000 (25.4)	.430 (10.9)	1.000 (25.4)	3.060 (77.7)	2.620 (66.5)			
20	2.875 - 16 UN	1.000 (25.4)	.430 (10.9)	1.000 (25.4)	3.680 (93.5)	3.120 (79.2)			
24	3.375 - 16 UN	1.000 (25.4)	.430 (10.9)	1.000 (25.4)	4.380 (111.3)	3.620 (91.9)			

1. The function of the M24758/2 fitting is to terminate flexible shielding conduit and to provide a standard thread for attaching all M24758/9 through M24758/19 fittings.
2. Metric dimensions (mm) are indicated in parentheses.
3. For complete dimensions see applicable Military Specification.

M24758/3 45° Conduit Fitting

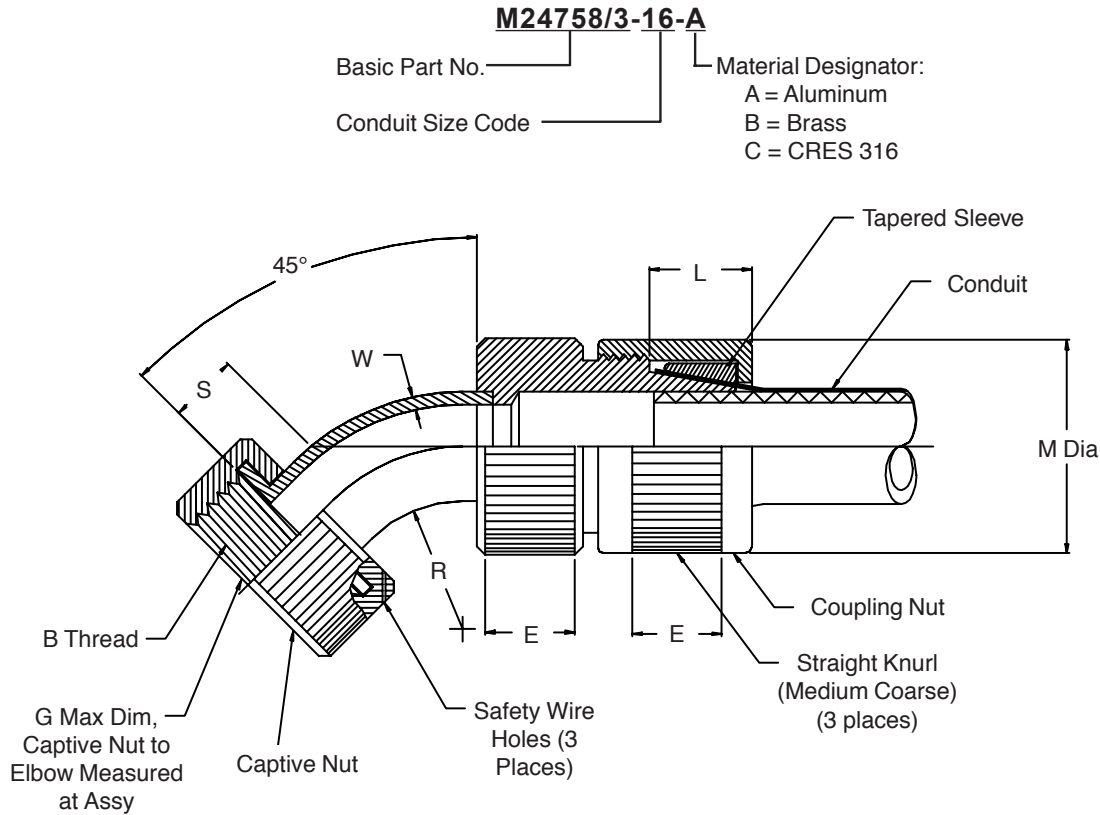

TABLE I

Conduit Size Code	B Thread (Class 2B)	E Knurl Length		G	L CONE LENGTH		M Dia (Maximum)	S	R Bend Radius		W Wall Thickness (Minimum)
		±.06 (15.2)	±.02 (.5)		±.06 (15.2)	±.06 (15.2)			±.06 (15.2)	±.06 (15.2)	
02	0.438- 28 UNEF	.500 (12.7)	.140 (3.6)	.140 (3.6)	.750 (19.1)	.930 (23.6)	.370 (9.4)	.430 (10.9)	.028 (.7)		
03	0.563- 24 UNEF	.500 (12.7)	.170 (4.3)	.170 (4.3)	.750 (19.1)	1.120 (28.4)	.370 (9.4)	.560 (14.2)	.028 (.7)		
04	0.688- 24 UNEF	.620 (15.7)	.170 (4.3)	.170 (4.3)	.750 (19.1)	1.250 (31.8)	.370 (9.4)	.750 (19.1)	.028 (.7)		
05	0.813- 20 UNEF	.620 (15.7)	.230 (5.8)	.230 (5.8)	.750 (19.1)	1.430 (36.3)	.370 (9.4)	.870 (22.1)	.028 (.7)		
06	0.938- 20 UNEF	.750 (19.1)	.230 (5.8)	.230 (5.8)	.750 (19.1)	1.620 (41.1)	.370 (9.4)	1.060 (26.9)	.028 (.7)		
08	1.250- 18 UNEF	.750 (19.1)	.290 (7.4)	.290 (7.4)	1.000 (25.4)	1.810 (46.0)	.430 (10.9)	1.370 (34.8)	.028 (.7)		
10	1.563- 18 UNEF	.870 (22.1)	.290 (7.4)	.290 (7.4)	1.000 (25.4)	2.180 (55.4)	.430 (10.9)	1.680 (42.7)	.028 (.7)		
12	1.875- 16 UN	.870 (22.1)	.350 (8.9)	.350 (8.9)	1.000 (25.4)	2.560 (65.0)	.430 (10.9)	2.060 (52.3)	.058 (1.5)		
16	2.375- 16 UN	1.000 (25.4)	.350 (8.9)	.350 (8.9)	1.000 (25.4)	3.060 (77.7)	.430 (10.9)	2.680 (68.1)	.058 (1.5)		
20	2.875- 16 UN	1.000 (25.4)	.350 (8.9)	.350 (8.9)	1.000 (25.4)	3.680 (93.5)	.430 (10.9)	3.310 (84.1)	.058 (1.5)		
24	3.375- 16 UN	1.000 (25.4)	.350 (8.9)	.350 (8.9)	1.000 (25.4)	4.380(111.3)	.500 (12.7)	4.500(114.3)	.058 (1.5)		

1. The function of the M24758/3 fitting is to terminate flexible shielding conduit and to provide a standard thread for attaching all M24758/9 through M24758/19 fittings.
2. Metric dimensions (mm) are indicated in parentheses.
3. For complete dimensions see applicable Military Specification.

M24758/4 90° Conduit Fitting



Conduit & Accessories

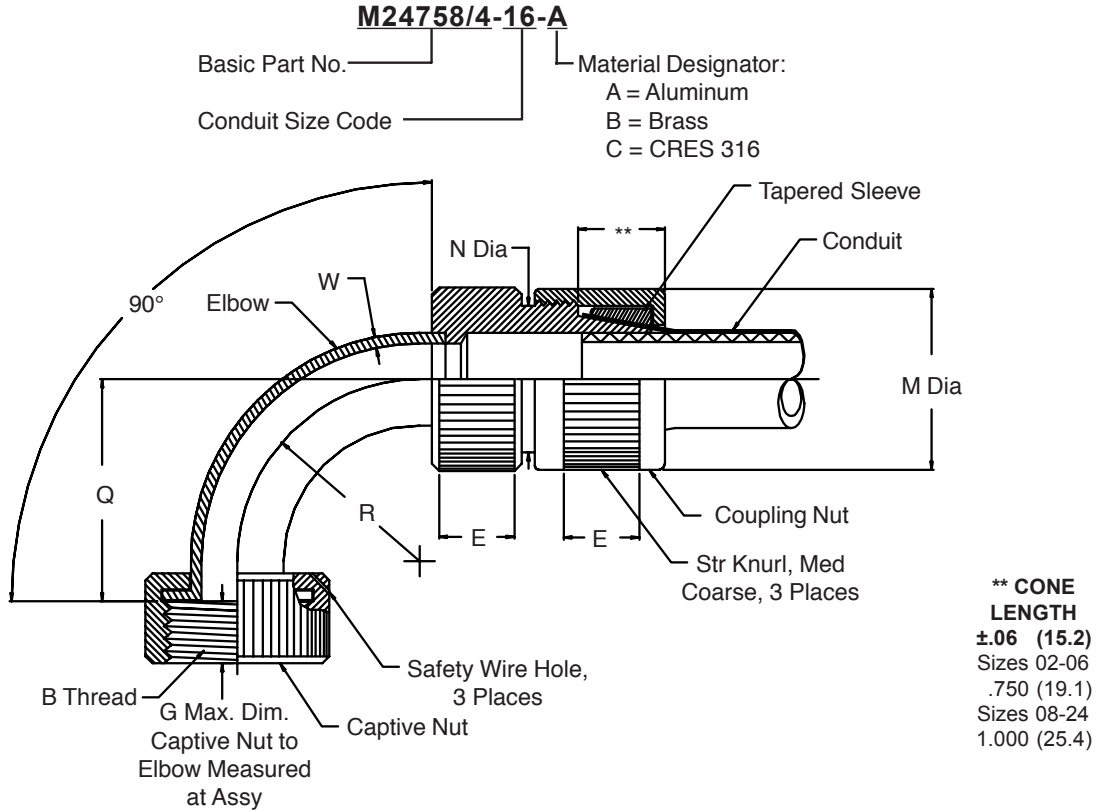

TABLE I

Conduit Size Code	B Thread (Class 2B)	E Knurl Length ±.06 (15.2)	G +.01 (-.02) (.3)	M Dia (Maximum)	N Dia (Maximum)	Q ±.06 (15.2)	R Bend Radius ±.06 (15.2)	W Wall Thickness (Minimum)
02	0.438- 28 UNEF	.500 (12.7)	.140 (3.6)	.930 (23.6)	.700 (17.8)	.810 (20.6)	.430 (10.9)	.028 (.7)
03	0.563- 24 UNEF	.500 (12.7)	.170 (4.3)	1.120 (28.4)	.820 (20.8)	.930 (23.6)	.560 (14.2)	.028 (.7)
04	0.688- 24 UNEF	.620 (15.7)	.170 (4.3)	1.250 (31.8)	.970 (24.6)	1.120 (28.4)	.750 (19.1)	.028 (.7)
05	0.813- 20 UNEF	.620 (15.7)	.230 (5.8)	1.430 (36.3)	1.120 (28.4)	1.250 (31.8)	.870 (22.1)	.028 (.7)
06	0.938- 20 UNEF	.750 (19.1)	.230 (5.8)	1.620 (41.1)	1.220 (31.0)	1.700 (43.2)	1.060 (26.9)	.028 (.7)
08	1.250- 18 UNEF	.750 (19.1)	.290 (7.4)	1.810 (46.0)	1.530 (38.9)	1.810 (46.0)	1.370 (34.8)	.028 (.7)
10	1.563- 18 UNEF	.870 (22.1)	.290 (7.4)	2.180 (55.4)	1.810 (46.0)	2.120 (53.8)	1.680 (42.7)	.028 (.7)
12	1.875- 16 UN	.870 (22.1)	.350 (8.9)	2.560 (65.0)	2.120 (53.8)	2.500 (63.5)	2.060 (52.3)	.058 (1.5)
16	2.375- 16 UN	1.000 (25.4)	.350 (8.9)	3.060 (77.7)	2.620 (66.5)	3.120 (79.2)	2.680 (68.1)	.058 (1.5)
20	2.875- 16 UN	1.000 (25.4)	.350 (8.9)	3.680 (93.5)	3.120 (79.2)	3.250 (82.6)	3.310 (84.1)	.058 (1.5)
24	3.375- 16 UN	1.000 (25.4)	.350 (8.9)	4.380(111.3)	3.620 (91.9)	4.500(114.3)	4.500(114.3)	.058 (1.5)

1. The function of the M24758/4 fitting is to terminate flexible shielding conduit and to provide a standard thread for attaching all M24758/9 through M24758/19 fittings.
2. Metric dimensions (mm) are indicated in parentheses.
3. For complete dimensions see applicable Military Specification.

M24758/5 Conduit-to-Panel Fitting

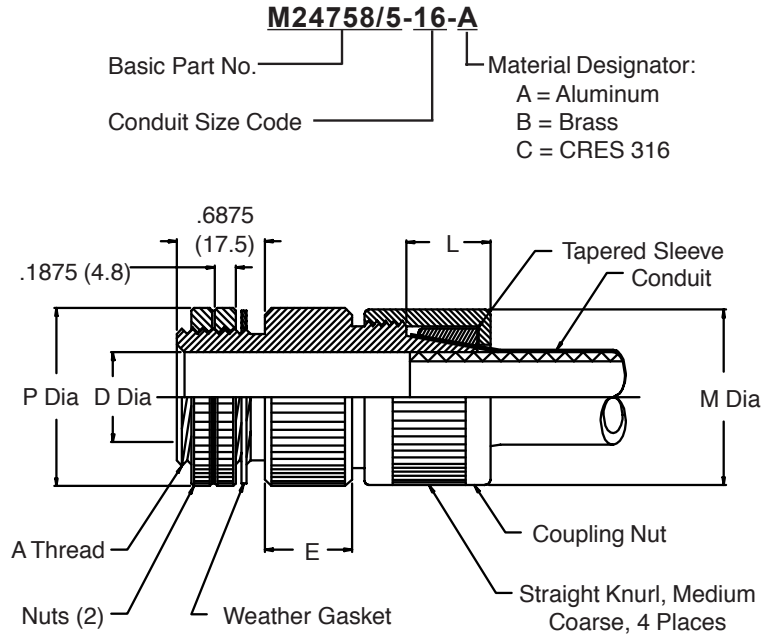

TABLE I

Conduit Size Code	A Thread (Class 2A)	D Dia (Minimum)	E Knurl Length ±.06 (15.2)	L Cone Length ±.06 (15.2)	M Dia (Maximum)	P Dia (Minimum)
02	0.625 - 24 UNEF	.250 (6.4)	.500 (12.7)	.750 (19.1)	.930 (23.6)	.870 (22.1)
03	0.750 - 20 UNEF	.370 (9.4)	.500 (12.7)	.750 (19.1)	1.120 (28.4)	1.000 (25.4)
04	0.875 - 20 UNEF	.500 (12.7)	.620 (15.7)	.750 (19.1)	1.250 (31.8)	1.120 (28.4)
05	1.000 - 20 UNEF	.620 (15.7)	.620 (15.7)	.750 (19.1)	1.430 (36.3)	1.250 (31.8)
06	1.188 - 18 UNEF	.750 (19.1)	.750 (19.1)	.750 (19.1)	1.620 (41.1)	1.430 (36.3)
08	1.438 - 18 UNEF	1.000 (25.4)	.750 (19.1)	1.000 (25.4)	1.810 (46.0)	1.680 (42.7)
10	1.750 - 16 UN	1.250 (31.8)	.870 (22.1)	1.000 (25.4)	2.180 (55.4)	2.000 (50.8)
12	2.000 - 16 UN	1.500 (38.1)	.870 (22.1)	1.000 (25.4)	2.560 (65.0)	2.250 (57.2)
16	2.500 - 16 UN	2.000 (50.8)	1.000 (25.4)	1.000 (25.4)	3.060 (77.7)	3.000 (76.2)
20	3.000 - 16 UN	2.500 (63.5)	1.000 (25.4)	1.000 (25.4)	3.680 (93.5)	3.500 (88.9)
24	3.500 - 16 UN	3.000 (76.2)	1.000 (25.4)	1.000 (25.4)	4.380 (111.3)	4.000 (101.6)

1. The function of the M24758/5 fitting is to terminate flexible shielding conduit directly to a panel. Two jam nuts are supplied with this fitting. One nut secures the fitting to the panel, and a second nut acts as a lock nut to the first.
2. Metric dimensions (mm) are indicated in parentheses.
3. For complete dimensions see applicable Military Specification.

M24758/6 Conduit-to-Pipe Fittings



Conduit & Accessories

M24758/6-16-A

Basic Part No. ————
 Conduit Size Code ————

Material Designator:
 A = Aluminum
 B = Brass
 C = CRES 316

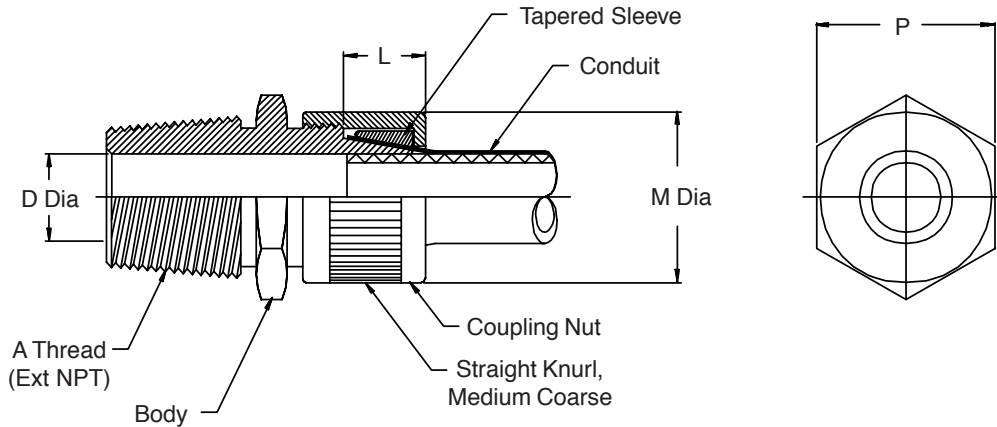

TABLE I

Conduit Size Code	A Thread (Class 2A)	D Dia (Minimum)	L Cone Length $\pm .06$ (15.2)	M Dia (Maximum)	P Dia (Minimum)
02	0.250 - 18.00 NPT	.250 (6.4)	.750 (19.1)	.930 (23.6)	.750 (19.1)
03	0.375 - 18.00 NPT	.370 (9.4)	.750 (19.1)	1.120 (28.4)	.870 (22.1)
04	0.500 - 14.00 NPT	.500 (12.7)	.750 (19.1)	1.250 (31.8)	.960 (24.4)
05	0.750 - 14.00 NPT	.620 (15.7)	.750 (19.1)	1.430 (36.3)	1.180 (30.0)
06	0.750 - 14.00 NPT	.750 (19.1)	.750 (19.1)	1.620 (41.1)	1.370 (34.8)
08	1.000 - 11.50 NPT	1.000 (25.4)	1.000 (25.4)	1.810 (46.0)	1.500 (38.1)
10	1.250 - 11.50 NPT	1.250 (31.8)	1.000 (25.4)	2.180 (55.4)	1.810 (46.0)
12	1.500 - 11.50 NPT	1.500 (38.1)	1.000 (25.4)	2.560 (65.0)	2.120 (53.8)
16	2.000 - 11.50 NPT	2.000 (50.8)	1.000 (25.4)	3.060 (77.7)	2.620 (66.5)
20	2.500 - 8.00 NPT	2.500 (63.5)	1.000 (25.4)	3.680 (93.5)	3.250 (82.6)
24	3.000 - 8.00 NPT	3.000 (76.2)	1.000 (25.4)	4.380 (111.3)	3.870 (98.3)

1. The function of the M24758/6 fitting is to terminate flexible shielding conduit with a reusable fitting having an external tapered pipe thread.
2. Metric dimensions (mm) are indicated in parentheses.
3. For complete dimensions see applicable Military Specification.

M24758/7 Conduit-to-Stuffing Tube Fitting

M24758/7-04-B-A

Basic Part No. _____
 Conduit Size Code _____
 Stuffing Tube Size Code _____

Material Designator:
 A = Aluminum
 B = Brass
 C = CRES 316

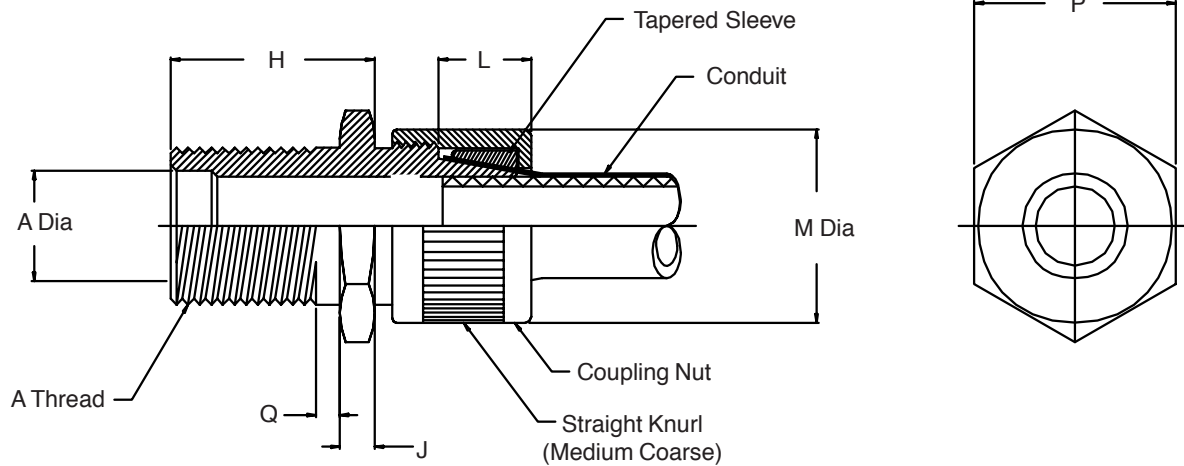

1. The M24758/7 adapter couples MIL-S-24235/9 through MIL-S-24235/17 stuffing tubes to M24758/1 conduit.
2. Any combination of conduit and stuffing tube sizes may be ordered by identifying the appropriate conduit size and stuffing tube size in the part number configuration.
3. Metric dimensions (mm) are indicated in parentheses.
4. For complete dimensions see applicable Military Specification.

M24758/7 Conduit-to-Stuffing Tube Fitting



Conduit & Accessories

TABLE I		
Conduit Size Code	L	
	Cone Length ±.06 (15.2)	M Dia (Maximum)
02	.750 (19.1)	.930 (23.6)
03	.750 (19.1)	1.120 (28.4)
04	.750 (19.1)	1.250 (31.8)
05	.750 (19.1)	1.430 (36.3)
06	.750 (19.1)	1.620 (41.1)
08	1.000 (25.4)	1.810 (46.0)
10	1.000 (25.4)	2.180 (55.4)
12	1.000 (25.4)	2.560 (65.0)
16	1.000 (25.4)	3.060 (77.7)
20	1.000 (25.4)	3.680 (93.5)
24	1.000 (25.4)	4.380 (111.3)

TABLE II									
MIL-S-24235 Stuffing Tube Size Code	A Thread (Class 2A)	A Dia	H ±.02 (.5)	J ±.02 (.5)	P Dim (Minimum)	Q ±.02 (.5)			
A	0.875 - 12 UN	.406 (10.3)	1.063 (27.0)	.188 (4.8)	1.031 (26.2)	.188 (4.8)			
B	1.000 - 12 UN	.515 (13.1)	1.063 (27.0)	.188 (4.8)	1.125 (28.6)	.188 (4.8)			
C	1.125 - 12 UN	.640 (16.3)	1.063 (27.0)	.188 (4.8)	1.250 (31.8)	.188 (4.8)			
D	1.250 - 12 UN	.750 (19.1)	1.063 (27.0)	.188 (4.8)	1.375 (34.9)	.188 (4.8)			
E	1.250 - 12 UN	.812 (20.6)	1.063 (27.0)	.188 (4.8)	1.375 (34.9)	.188 (4.8)			
F	1.313 - 12 UN	.843 (21.4)	1.188 (30.2)	.188 (4.8)	1.438 (36.5)	.188 (4.8)			
G	1.500 - 12 UN	.935 (23.7)	1.188 (30.2)	.188 (4.8)	1.656 (42.1)	.188 (4.8)			
J	1.625 - 12 UN	1.062 (27.0)	1.188 (30.2)	.188 (4.8)	1.781 (45.2)	.188 (4.8)			
K	1.750 - 12 UN	1.171 (29.7)	1.500 (38.1)	.188 (4.8)	1.875 (47.6)	.188 (4.8)			
L	1.813 - 12 UN	1.265 (32.1)	1.500 (38.1)	.188 (4.8)	1.938 (49.2)	.188 (4.8)			
M	2.000 - 12 UN	1.406 (35.7)	1.500 (38.1)	.250 (6.4)	2.188 (55.6)	.188 (4.8)			
N	2.063 - 12 UN	1.515 (38.5)	1.563 (39.7)	.250 (6.4)	2.250 (57.2)	.188 (4.8)			
P	2.188 - 12 UN	1.625 (41.3)	1.563 (39.7)	.250 (6.4)	2.344 (59.5)	.188 (4.8)			
R	2.313 - 12 UN	1.750 (44.5)	1.563 (39.7)	.250 (6.4)	2.469 (62.7)	.188 (4.8)			
S	2.688 - 12 UN	1.875 (47.6)	2.188 (55.6)	.313 (8.0)	2.813 (71.5)	.250 (6.4)			
T	2.875 - 12 UN	2.062 (52.4)	2.188 (55.6)	.313 (8.0)	2.969 (75.4)	.250 (6.4)			
V	3.000 - 12 UN	2.187 (55.5)	2.188 (55.6)	.313 (8.0)	3.094 (78.6)	.250 (6.4)			
W	3.125 - 12 UN	2.312 (58.7)	2.188 (55.6)	.313 (8.0)	3.281 (83.3)	.250 (6.4)			
X	3.250 - 12 UN	2.500 (63.5)	2.188 (55.6)	.313 (8.0)	3.438 (87.3)	.250 (6.4)			
Y	3.375 - 12 UN	2.609 (66.3)	2.188 (55.6)	.313 (8.0)	3.563 (90.5)	.250 (6.4)			
Z	3.563 - 12 UN	2.781 (70.6)	2.188 (55.6)	.313 (8.0)	3.750 (95.3)	.250 (6.4)			
AA	3.750 - 12 UN	2.875 (73.0)	3.125 (79.4)	.438 (11.1)	3.875 (98.4)	.250 (6.4)			
BB	4.000 - 12 UN	3.157 (80.2)	3.125 (79.4)	.438 (11.1)	4.125 (104.8)	.250 (6.4)			

To Most People It's Just a Rubber Connector Cover

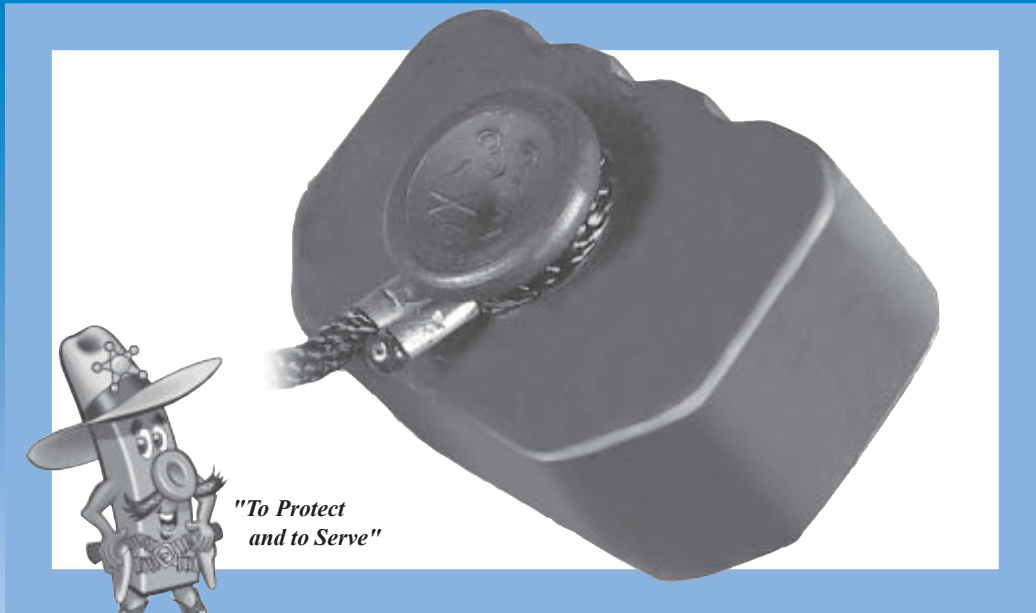

At Glenair It's a Good Ol' "Marshal Bean"

We're always hard at work at Glenair developing new and improved interconnect products and accessories. Our "Marshal Bean" Protective Rubber Covers are a fine example—even if they *have* been around for a month of Sunday's.

"Marshal Beans" provide robust physical and environmental protection while eliminating the damage caused when metal connector covers bang against equipment housings, or when test cables get dragged across the shop floor! The covers come in two material types: a

flexible neoprene rubber or a proprietary conductive material which dissipates static electricity.

Glenair Bean Rubber Covers have been available for years, but this catalog introduces four new universal models that make order-entry a snap for standard MIL-C-24308 D-Subminiature's, MIL-DTL-83513 Micro-D's, ARINC 400's and all uniformly rectangular connectors. At Glenair, we reckon a flexible rubber cover is the perfect way to protect an interconnect cable. So isn't it time you hired "Marshal Bean" to ride herd on your connector investment?



1211 Air Way

Glendale, California 91201-2497

Telephone: 818-247-6000 · Facsimilie: 818-500-9912 · EMail: sales@glenair.com

United States · United Kingdom · Germany · Nordic · France · Italy · Spain

www.glenair.com

M24758/8 Conduit-to-Conduit Fitting



Conduit & Accessories

M24758/8-16-A

Basic Part No. ————
 Conduit Size Code ————

Material Designator:
 A = Aluminum
 B = Brass
 C = CRES 316

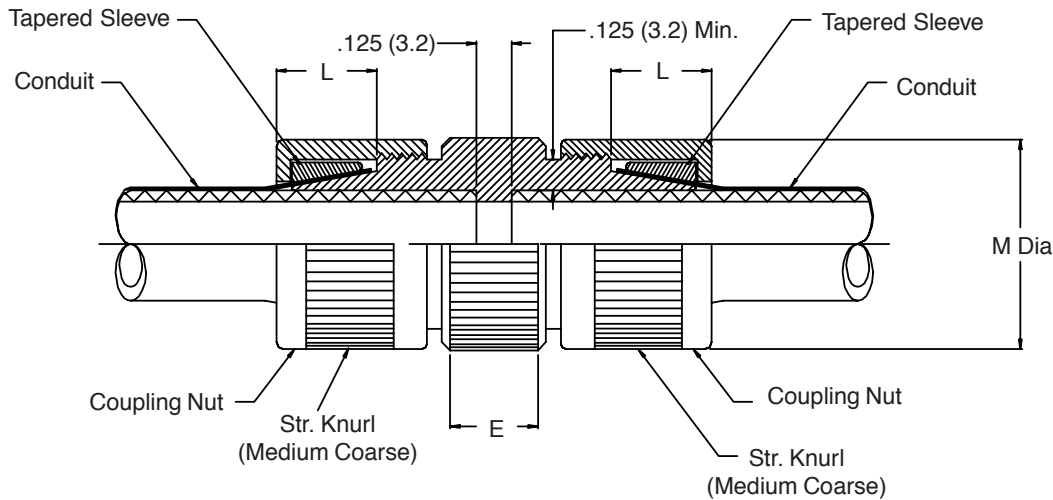

TABLE I

Conduit Size Code	E Knurl Length		L Cone Length		M Dia (Maximum)
	±.06	(15.2)	±.06	(15.2)	
02	.500	(12.7)	.750	(19.1)	.930 (23.6)
03	.500	(12.7)	.750	(19.1)	1.120 (28.4)
04	.560	(14.2)	.750	(19.1)	1.250 (31.8)
05	.560	(14.2)	.750	(19.1)	1.430 (36.3)
06	.620	(15.7)	.750	(19.1)	1.620 (41.1)
08	.620	(15.7)	1.000	(25.4)	1.810 (46.0)
10	.680	(17.3)	1.000	(25.4)	2.180 (55.4)
12	.680	(17.3)	1.000	(25.4)	2.560 (65.0)
16	.750	(19.1)	1.000	(25.4)	3.060 (77.7)
20	.750	(19.1)	1.000	(25.4)	3.680 (93.5)
24	.750	(19.1)	1.000	(25.4)	4.380 (111.3)

1. The function of the M24758/8 conduit-to-conduit fitting is to connect two sections of flexible shielding conduit. Consult factory to mate two different sizes of conduit.
2. Metric dimensions (mm) are indicated in parentheses.
3. For complete dimensions see applicable Military Specification.

M24758/9 Adapter for MIL-DTL-5015 Series 3100 Connectors

M24758/9-16-06-01-A

Basic Part No. ————

Conduit Size Code (See Table I) ————

A-Thread Code (See Table II) ————

Material Designator:
 A = Aluminum
 B = Brass
 C = CRES 316

Style Designator ————

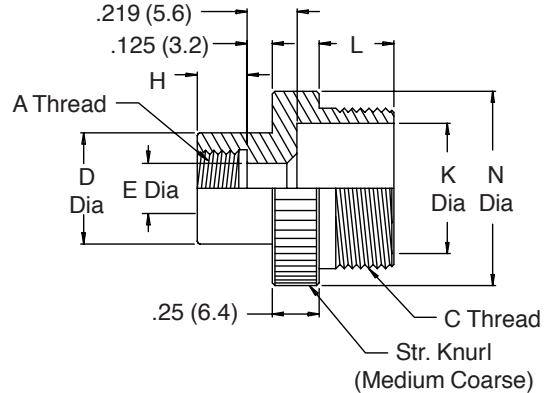
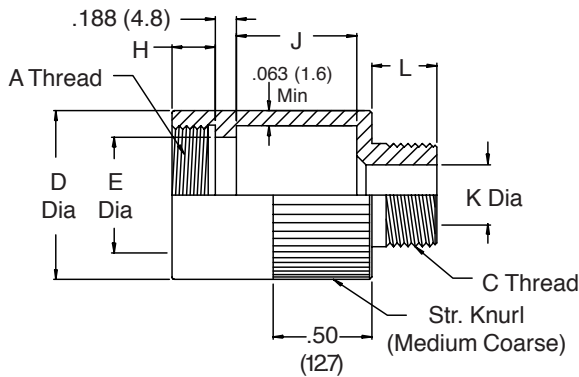

STYLE 01
 FOR USE WHEN E DIAMETER IS
 GREATER THAN K DIAMETER

STYLE 02
 SAME AS STYLE 01 EXCEPT
 J DIMENSION IS ZERO

STYLE 03
 FOR USE WHEN E DIAMETER IS
 EQUAL TO OR LESS THAN K DIAMETER

Conduit Size Code	C Thread (Class 2A)	L		K Dia Min.	N Dia
		±.02	(.5)		
02	0.438 - 28 UNEF	.210	(5.3)	.250 (6.4)	.687 (17.4)
03	0.563 - 24 UNEF	.250	(6.4)	.370 (9.4)	.812 (20.6)
04	0.688 - 24 UNEF	.250	(6.4)	.500 (12.7)	.937 (23.8)
05	0.813 - 20 UNEF	.310	(7.9)	.620 (15.7)	1.062 (27.0)
06	0.938 - 20 UNEF	.310	(7.9)	.750 (19.1)	1.187 (30.1)
08	1.250 - 18 UNEF	.370	(9.4)	1.000 (25.4)	1.500 (38.1)
10	1.563 - 18 UNEF	.370	(9.4)	1.250 (31.8)	1.812 (46.0)
12	1.875 - 16 UN	.430	(10.9)	1.500 (38.1)	2.125 (54.0)
16	2.375 - 16 UN	.430	(10.9)	2.000 (50.8)	2.625 (66.7)
20	2.875 - 16 UN	.430	(10.9)	2.500 (63.5)	3.125 (79.4)
24	3.375 - 16 UN	.430	(10.9)	3.000 (76.2)	3.625 (92.1)

- The M24758/9 adapter couples MIL-DTL-5015 connectors (MS3100, MS3101, MS3106, and MS-series backshells) to M24758/2, M24758/3 or M24758/4 fittings.
- For MIL-DTL-5015, MS3400 Series, the M24758/13 adapter may be used.
- Metric dimensions (mm) are indicated in parentheses.
- For complete dimensions see applicable Military Specification.

M24758/9 Adapter for MIL-DTL-5015 Series 3100 Connectors



Conduit &
Accessories

TABLE II (MIL-C-5015 Connector Codes)

Connector Code	Class	Manufacturer	Series
A		All Manufacturers	MS-Series Backshell
B	A	Amphenol	MS3100, MS3101, MS3106, 97-3100, 97-3101, 97-3106
C	E & R	Amphenol	MS3100, MS3101, MS3106, 69-3100, 69-3101, 69-3106
D	A, E & R	Bendix	MS3100, MS3101, MS3106, 10-214, 10-720, 10-721, 10-726
E	A	Cannon	MS3100, MS3101, MS3106, CA-3101, CA-3106
F	E & R	Cannon	MS3100, MS3101, MS3106,

TABLE III (A Thread Code and Adapter Dimensions)

A Thread Code	Conn. Shell Size	Conn. Code (Table II)	A Thread (Class 2B)		H		D Dia		E Dia		J Style 01*	
				±.02	(.5)	±.02	(.5)	±.02	(.5)	±.03	(.8)	
01	8S	D	0.375 - 32 UNEF	.180	(4.6)	.500	(12.7)	.280	(7.1)	.500	(12.7)	
02	8S	B	0.438 - 27 UNS	.210	(5.3)	.560	(14.2)	.340	(8.6)	.530	(13.5)	
03	8	C, E, F	0.438 - 28 UNEF	.210	(5.3)	.560	(14.2)	.340	(8.6)	.530	(13.5)	
04	8S	A	0.500 - 28 UNEF	.210	(5.3)	.620	(15.7)	.370	(9.4)	.560	(14.2)	
04	10S	A, B, C, D, E	0.500 - 28 UNEF	.210	(5.3)	.620	(15.7)	.370	(9.4)	.560	(14.2)	
05	10S	E	0.563 - 24 UNEF	.250	(6.4)	.680	(17.3)	.450	(11.4)	.590	(15.0)	
05	10SL	E, F	0.563 - 24 UNEF	.250	(6.4)	.680	(17.3)	.450	(11.4)	.590	(15.0)	
06	10SL	A, B, C, D	0.625 - 24 UNEF	.250	(6.4)	.750	(19.1)	.500	(12.7)	.620	(15.7)	
06	12, 12S	A, D, F	0.625 - 24 UNEF	.250	(6.4)	.750	(19.1)	.500	(12.7)	.620	(15.7)	
07	12, 12S	B, C, E	0.688 - 24 UNEF	.250	(6.4)	.810	(20.6)	.570	(14.5)	.650	(16.5)	
08	12SL	A	0.750 - 20 UNEF	.280	(7.1)	.870	(22.1)	.620	(15.7)	.680	(17.3)	
08	14, 14S	A, B, C, D, E, F	0.750 - 20 UNEF	.280	(7.1)	.870	(22.1)	.620	(15.7)	.680	(17.3)	
09	16, 16S	A, B, C, D, E, F	0.875 - 20 UNEF	.280	(7.1)	1.000	(25.4)	.750	(19.1)	.710	(18.0)	
10	18	A, B, C, D, E, F	1.000 - 20 UNEF	.280	(7.1)	1.120	(28.4)	.870	(22.1)	.750	(19.1)	
11	20	B, D, E, F	1.125 - 18 UNEF	.280	(7.1)	1.250	(31.8)	1.000	(25.4)	.780	(19.8)	
12	20	C	1.125 - 24 UNS	.280	(7.1)	1.250	(31.8)	1.000	(25.4)	.780	(19.8)	
13	20, 22	A	1.188 - 18 UNEF	.280	(7.1)	1.310	(33.3)	1.060	(26.9)	.810	(20.6)	
14	22	B, C, D, E, F	1.250 - 18 UNEF	.280	(7.1)	1.370	(34.8)	1.120	(28.4)	.870	(22.1)	
15	24	B, C, D, E, F	1.375 - 18 UNEF	.280	(7.1)	1.500	(38.1)	1.250	(31.8)	1.000	(25.4)	
16	24, 28	A	1.438 - 18 UNEF	.280	(7.1)	1.560	(39.6)	1.310	(33.3)	1.060	(26.9)	
17	28	B, C, D, E, F	1.625 - 18 UNEF	.280	(7.1)	1.750	(44.5)	1.500	(38.1)	1.120	(28.4)	
18	32	A	1.750 - 18 UNS	.280	(7.1)	1.870	(47.5)	1.620	(41.1)	1.180	(30.0)	
19	32	D, E, F	1.875 - 16 UN	.280	(7.1)	2.000	(50.8)	1.750	(44.5)	1.250	(31.8)	
20	32	B, C	1.906 - 18	.280	(7.1)	2.030	(51.6)	1.780	(45.2)	1.280	(32.5)	
21	36	A	2.000 - 18 UNS	.280	(7.1)	2.120	(53.8)	1.870	(47.5)	1.340	(34.0)	
22	36	D	2.063 - 16 UNS	.310	(7.9)	2.180	(55.4)	1.930	(49.0)	1.370	(34.8)	
23	36	C	2.063 - 20	.280	(7.1)	2.180	(55.4)	1.930	(49.0)	1.370	(34.8)	
24	36	E, F	2.125 - 16 UN	.310	(7.9)	2.250	(57.2)	2.000	(50.8)	1.400	(35.6)	
25	36	B	2.125 - 18 UN	.280	(7.1)	2.250	(57.2)	2.000	(50.8)	1.400	(35.6)	
26	40	A	2.250 - 16 UN	.310	(7.9)	2.370	(60.2)	2.120	(53.8)	1.500	(38.1)	
27	40	D	2.313 - 16 UNS	.310	(7.9)	2.430	(61.7)	2.180	(55.4)	1.560	(39.6)	
28	40	B, E, F	2.375 - 16 UN	.310	(7.9)	2.500	(63.5)	2.250	(57.2)	1.620	(41.1)	
29	44	B, F	2.625 - 16 UN	.310	(7.9)	2.750	(69.9)	2.500	(63.5)	1.870	(47.5)	
30	48	F	2.813 - 18	.280	(7.1)	2.930	(74.4)	2.680	(68.1)	2.060	(52.3)	
31	48	B	2.875 - 16 UN	.310	(7.9)	3.000	(76.2)	2.750	(69.9)	2.120	(53.8)	

* For Style 02, J Dimension is zero.

© 2005 Glenair, Inc.

CAGE Code 06324

Printed in U.S.A.

GLENAIR, INC. • 1211 AIR WAY • GLENDALE, CA 91201-2497 • 818-247-6000 • FAX 818-500-9912
www.glenair.com 71-13 E-Mail: sales@glenair.com

M24758/10 Adapter for Triaxial Connectors

M24758/10-16-01-01-A

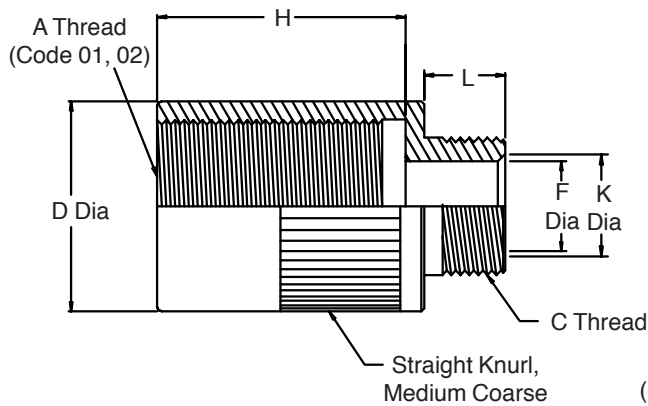
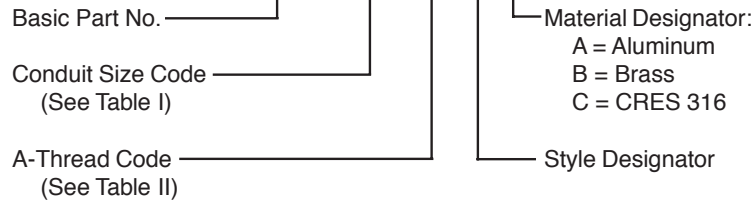

STYLE 01
ADAPTER WITH
INTERNAL "A" THREAD

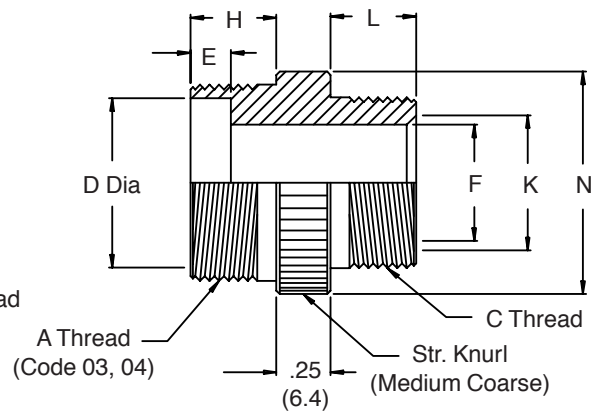

STYLE 02
ADAPTER WITH
EXTERNAL "A" THREAD

1. The M24758/10 adapter couples triaxial connectors to M24758/2, M24758/3 or M24758/4 fittings.
2. Metric dimensions (mm) are indicated in parentheses.
3. For complete dimensions see applicable Military Specification.

M24758/10 Adapter for Triaxial Connectors



Conduit &
Accessories

TABLE I

Conduit Size Code	C Thread (Class 2A)	L		K Dia Min.		N Dia ±.02 (.5)	
		±.02	(.5)				
02	0.438 - 28 UNEF	.210	(5.3)	.250	(6.4)	.687	(17.4)
03	0.563 - 24 UNEF	.250	(6.4)	.370	(9.4)	.812	(20.6)
04	0.688 - 24 UNEF	.250	(6.4)	.500	(12.7)	.937	(23.8)
05	0.813 - 20 UNEF	.310	(7.9)	.620	(15.7)	1.062	(27.0)
06	0.938 - 20 UNEF	.310	(7.9)	.750	(19.1)	1.187	(30.1)
08	1.250 - 18 UNEF	.370	(9.4)	1.000	(25.4)	1.500	(38.1)
10	1.563 - 18 UNEF	.370	(9.4)	1.250	(31.8)	1.812	(46.0)
12	1.875 - 16 UN	.430	(10.9)	1.500	(38.1)	2.125	(54.0)
16	2.375 - 16 UN	.430	(10.9)	2.000	(50.8)	2.625	(66.7)
20	2.875 - 16 UN	.430	(10.9)	2.500	(63.5)	3.125	(79.4)
24	3.375 - 16 UN	.430	(10.9)	3.000	(76.2)	3.625	(92.1)

TABLE II (MIL-DTL-5015 Connector Code)

A Thread Code	Connector Part Number			D Dia Min.	E Min.	F Dia Min.	N Dia ±.02 (.5)	Cable Reference	
	ITT/Cannon	Formerly Gremar	A Thread					Type	OD ±.02 (.5)
01	152105-2380	5633	0.750 - 16 UNF Class 2B	.875 (22.2)	--	.297 (7.5)	.562 (14.3)	RG-233/U .216 (5.5) RG-58C/U .195 (5.0)	
02	152100-2390	7991	0.875 - 20 UNEF Class 2B	1.000 (25.4)	--	.515 (13.1)	.500 (12.7)	RG-214/U .425 (10.8) RG-98/U .420 (10.7)	
03	152190-0000	16312	1.063 - 18 UNEF Class 2A	.922 (23.4)	.187 (4.7)	.564 (14.3)	.312 (7.9)	RG-14A/U .545 (13.8) RE-293A/U .545 (13.8) *TRF-8 .500 (12.7) RG-14A/U .545 (13.8)	
04		11865	1.063 - 18 UNEF Class 2A	.922 (23.4)	.227 (5.8)	.564 (14.3)	.335 (8.5)	RE-293A/U .545 (13.8) *TRF-8 .500 (12.7)	

* Times Wire and Cable Co.

M24758/11 Adapter for Coaxial Connectors



Conduit & Accessories

TABLE I

Conduit Size Code	C Thread (Class 2A)	L		K Dia Min.		N Dia	
		±.02	(.5)			±.02	(.5)
02	0.438 - 28 UNEF	.210	(5.3)	.250	(6.4)	.687	(17.4)
03	0.563 - 24 UNEF	.250	(6.4)	.370	(9.4)	.812	(20.6)
04	0.688 - 24 UNEF	.250	(6.4)	.500	(12.7)	.937	(23.8)
05	0.813 - 20 UNEF	.310	(7.9)	.620	(15.7)	1.062	(27.0)
06	0.938 - 20 UNEF	.310	(7.9)	.750	(19.1)	1.187	(30.1)
08	1.250 - 18 UNEF	.370	(9.4)	1.000	(25.4)	1.500	(38.1)
10	1.563 - 18 UNEF	.370	(9.4)	1.250	(31.8)	1.812	(46.0)
12	1.875 - 16 UN	.430	(10.9)	1.500	(38.1)	2.125	(54.0)
16	2.375 - 16 UN	.430	(10.9)	2.000	(50.8)	2.625	(66.7)
20	2.875 - 16 UN	.430	(10.9)	2.500	(63.5)	3.125	(79.4)
24	3.375 - 16 UN	.430	(10.9)	3.000	(76.2)	3.625	(92.1)

TABLE II (A Thread and Fitting Dimensions)

A Thread Code	C Thread (Class 2A)	H		D Dia		Coaxial Cable	
		±.03	(.8)	±.02	(.5)	Type	OD
02	0.375 - 32 UNEF	.210	(5.3)	.226	(5.7)	RG-58	.195 (5.0)
						RG-223	.216 (5.5)
04	0.438 - 28 UNEF	.250	(6.4)	.345	(8.8)	RG-5	.332 (8.4)
						RG-6	.332 (8.4)
						RG-21	.332 (8.4)
06	0.625 - 24 UNEF	.310	(7.9)	.433	(11.0)	RG-9	.420 (10.7)
						RG-214	.425 (10.8)
08	0.688 - 24 UNEF	.310	(7.9)	.568	(14.4)	RG-14	.545 (13.8)
						RG-293	.545 (13.8)
10	0.938 - 20 UNEF	.310	(7.9)	.650	(16.5)	RG-57	.625 (15.9)
						RG-294	.630 (16.0)
12	0.813 - 20 UNEF	.310	(7.9)	.895	(22.7)	RG-7	.870 (22.1)

M24758/12 Adapter for MIL-DTL-26482 Series I Connectors

M24758/12-16-01-01-A

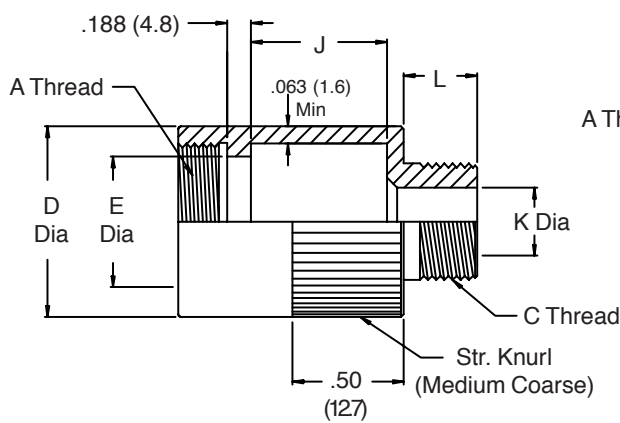
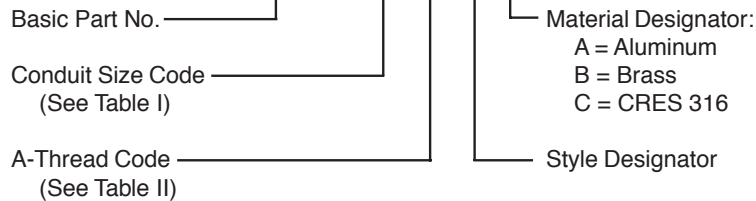

STYLE 01
FOR USE WHEN E DIAMETER IS
GREATER THAN K DIAMETER

STYLE 02
SAME AS STYLE 01 EXCEPT
J DIMENSION IS ZERO

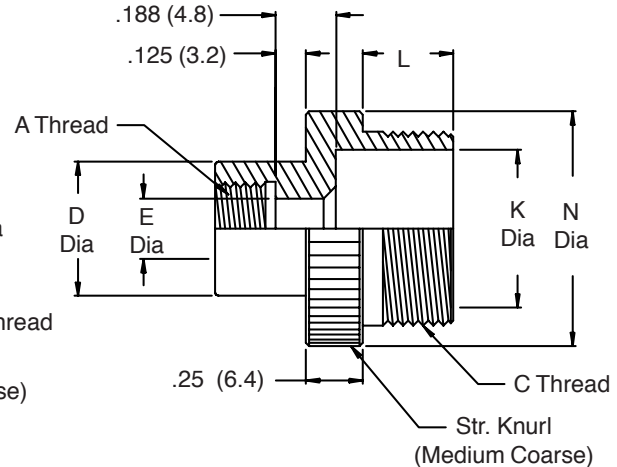

STYLE 03
FOR USE WHEN E DIAMETER IS
EQUAL TO OR LESS THAN K DIAMETER

1. The M24758/12 adapter couples MIL-DTL-26482 Series I connectors (MS3110, MS3111, or MS3116 series) to M24758/2, M24758/3 or M24758/4 fittings.
2. For MIL-DTL-26482 series 2, the M24758/13 adapter may be used.
3. Metric dimensions (mm) are indicated in parentheses.
4. For complete dimensions see applicable Military Specification.

M24758/12 Adapter for
MIL-DTL-26482 Series I Connectors



Conduit &
Accessories

TABLE I

Conduit Size Code	C Thread (Class 2A)	L		K Dia Min.		N Dia	
		±.02	(.5)			±.02	(.5)
02	0.438 - 28 UNEF	.210	(5.3)	.250	(6.4)	.687	(17.4)
03	0.563 - 24 UNEF	.250	(6.4)	.370	(9.4)	.812	(20.6)
04	0.688 - 24 UNEF	.250	(6.4)	.500	(12.7)	.937	(23.8)
05	0.813 - 20 UNEF	.310	(7.9)	.620	(15.7)	1.062	(27.0)
06	0.938 - 20 UNEF	.310	(7.9)	.750	(19.1)	1.187	(30.1)
08	1.250 - 18 UNEF	.370	(9.4)	1.000	(25.4)	1.500	(38.1)
10	1.563 - 18 UNEF	.370	(9.4)	1.250	(31.8)	1.812	(46.0)
12	1.875 - 16 UN	.430	(10.9)	1.500	(38.1)	2.125	(54.0)
16	2.375 - 16 UN	.430	(10.9)	2.000	(50.8)	2.625	(66.7)
20	2.875 - 16 UN	.430	(10.9)	2.500	(63.5)	3.125	(79.4)
24	3.375 - 16 UN	.430	(10.9)	3.000	(76.2)	3.625	(92.1)

TABLE II (A Thread Code and Adapter Dimensions)

A Thread Code	Connector Shell Size	A Thread (Class 2B)	D Dia		E Dia		J Style 01	
			±.02	(.5)	±.02	(.5)	±.02	(.5)
07	08	0.438 - 28 UNEF	.590	(15.0)	.340	(8.6)	.870	(22.1)
09	10	0.563 - 24 UNEF	.710	(18.0)	.450	(11.4)	.870	(22.1)
11	12	0.688 - 24 UNEF	.840	(21.3)	.570	(14.5)	.870	(22.1)
13	14	0.813 - 20 UNEF	.960	(24.4)	.680	(17.3)	.870	(22.1)
15	16	0.938 - 20 UNEF	1.090	(27.7)	.810	(20.6)	.870	(22.1)
17	18	1.063 - 18 UNEF	1.210	(30.7)	.930	(23.6)	1.060	(26.9)
19	20	1.188 - 18 UNEF	1.340	(34.0)	1.060	(26.9)	1.180	(30.0)
21	22	1.313 - 18 UNEF	1.460	(37.1)	1.180	(30.0)	1.620	(41.1)
23	24	1.438 - 18 UNEF	1.590	(40.4)	1.310	(33.3)	1.680	(42.7)

M24758/13 Adapter for Connectors with AS85049 Fig 4 Accessory Interface

M24758/13-16-08-01-A

Basic Part No. _____
 Conduit Size Code _____
 (See Table I)
 Connector Dash Number _____
 (See Table II)

Material Designator:
 A = Aluminum
 B = Brass
 C = CRES 316

Style Designator

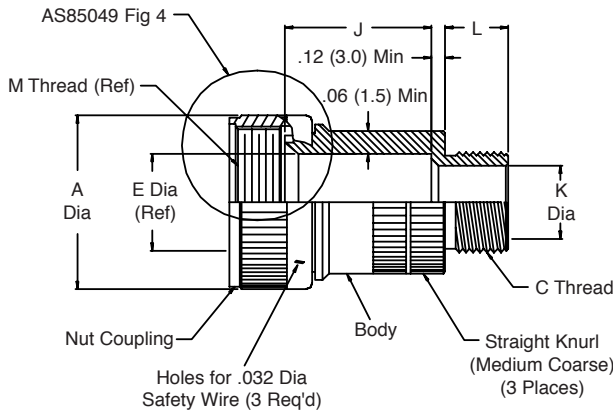

STYLE 01
 FOR USE WHEN E DIAMETER IS
 GREATER THAN K DIAMETER

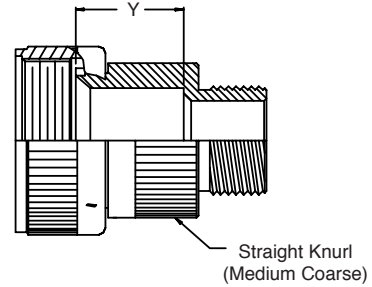

STYLE 02
 SAME AS STYLE 01 EXCEPT Y
 DIMENSION IS LESS THAN J. STYLE
 02 IS USED WHEN THE EXTRA
 WORKING ROOM PROVIDED BY
 DIMENSION J OF STYLE 01 IS NOT A
 REQUIREMENT.

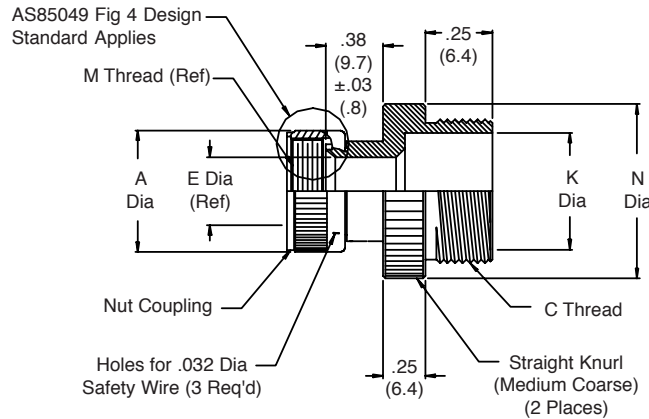

STYLE 03
 FOR USE WHEN E DIAMETER IS
 EQUAL TO OR LESS THAN K DIAMETER

M24758/13 Adapter for Connectors with AS85049 Fig 4 Accessory Interface



Conduit & Accessories

TABLE I

Conduit Size Code	C Thread (Class 2A)	L ±.02 (.5)	K Dia Min.	N Dia ±.02 (.5)
02	0.438 - 28 UNEF	.210 (5.3)	.250 (6.4)	.687 (17.4)
03	0.563 - 24 UNEF	.250 (6.4)	.370 (9.4)	.812 (20.6)
04	0.688 - 24 UNEF	.250 (6.4)	.500 (12.7)	.937 (23.8)
05	0.813 - 20 UNEF	.310 (7.9)	.620 (15.7)	1.062 (27.0)
06	0.938 - 20 UNEF	.310 (7.9)	.750 (19.1)	1.187 (30.1)
08	1.250 - 18 UNEF	.370 (9.4)	1.000 (25.4)	1.500 (38.1)
10	1.563 - 18 UNEF	.370 (9.4)	1.250 (31.8)	1.812 (46.0)
12	1.875 - 16 UN	.430 (10.9)	1.500 (38.1)	2.125 (54.0)
16	2.375 - 16 UN	.430 (10.9)	2.000 (50.8)	2.625 (66.7)
20	2.875 - 16 UN	.430 (10.9)	2.500 (63.5)	3.125 (79.4)
24	3.375 - 16 UN	.430 (10.9)	3.000 (76.2)	3.625 (92.1)

TABLE II (Connector Dash Numbers & Fitting Dimensions)

Conn. Dash No.	NAS 1599 & MIL-DTL-83723 (Series 1 & 3)	MIL-DTL-5015 (MS3400 Series)	MIL-DTL-81703 (Navy) (Series 3)	MIL-DTL-26482 (Series 2)	A Dia. Max.	M Thread (Class 2B) (Ref.) (Note 3)	E Dia. (Ref) Note 3	J (Style 01) (Style 02)	Y (Style 02)
03	08	8SL	03	08	.669 (17.0)	0.563 - 24 UNEF	.270 (6.9)	1.060 (26.9)	.620 (15.7)
08	10	10S, 10SL		10	.617 (15.7)	0.500 - 20 UNF	.270 (6.9)	1.060 (26.9)	.620 (15.7)
10	12	12, 12S		12	.734 (18.6)	0.625 - 24 UNEF	.375 (9.5)	1.060 (26.9)	.690 (17.5)
12	14	14, 14S	07	13	.858 (21.8)	0.750 - 20 UNEF	.511 (13.0)	1.060 (26.9)	.690 (17.5)
14	16	16, 16S	12	16	.984 (25.0)	0.875 - 20 UNEF	.585 (14.9)	1.060 (26.9)	.750 (19.1)
16	18	18	19	18	1.112 (28.2)	1.000 - 20 UNEF	.710 (18.0)	1.060 (26.9)	.750 (19.1)
18	20	20	27	20	1.218 (30.9)	1.062 - 18 UNEF	.789 (20.0)	1.120 (28.4)	.750 (19.1)
20	22	22	37	22	1.345 (34.2)	1.188 - 18 UNEF	.914 (23.2)	1.380 (35.1)	.810 (20.6)
22	24	24		24	1.468 (37.3)	1.312 - 18 UNEF	1.039 (26.4)	1.830 (46.5)	.810 (20.6)
24		28			1.593 (40.5)	1.438 - 18 UNEF	1.154 (29.3)	1.830 (46.5)	.810 (20.6)
28		32			1.969 (50.0)	1.750 - 18 UNEF	1.389 (35.3)	2.300 (58.4)	.880 (22.4)
32		36			2.219 (56.4)	2.000 - 18 UNS	1.635 (41.5)	2.550 (64.8)	.880 (22.4)
36		40			2.469 (62.7)	2.250 - 16 UN	1.850 (47.0)	2.800 (71.1)	.880 (22.4)
40		44			2.719 (69.1)	2.500 - 16 UN	2.065 (52.5)	3.050 (77.5)	.940 (23.9)
44		48			2.969 (75.4)	2.750 - 16 UN	2.320 (58.9)	3.550 (90.2)	.940 (23.9)
48					3.219 (81.8)	3.000 - 16 UN	2.570 (65.3)	3.620 (91.9)	.940 (23.9)
61			61		1.653 (42.0)	1.500 - 18 UNEF	1.194 (30.3)	1.880 (47.8)	.810 (20.6)

1. The M24758/13 adapter couples connectors listed in Table I to M24758/2, M24758/3 or M24758/4 conduit fittings.
2. The coupling nut end of this adapter shall conform to Military Standard MS3155 (Navy), "Connector, electric, rear accessory design standard". AS85049 Fig 4 takes precedence over this specification.
3. The E diameter and M-thread of this drawing are the same as the E diameter and M-thread of MS3155, and are included for reference purposes.
4. Metric dimensions (mm) are indicated in parentheses.
5. For complete dimensions see applicable Military Specification.

M24758/14 Adapter for MIL-C-28840 (EC) Backshells

M24758/14-16-01-01-A

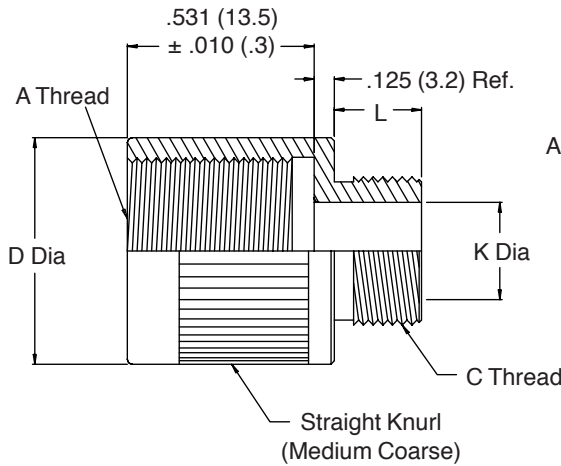
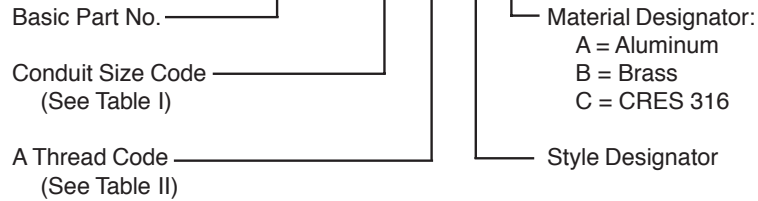

STYLE 01
FOR USE WHEN K DIAMETER IS
SMALLER THAN E DIAMETER

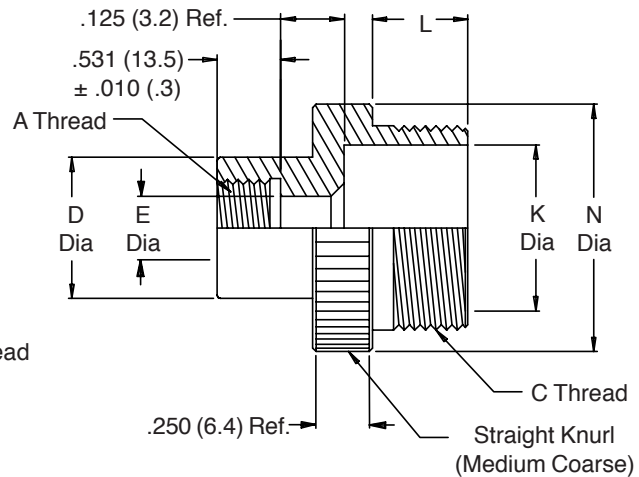

STYLE 02
FOR USE WHEN K DIAMETER
IS EQUAL TO OR LARGER THAN E DIAMETER

1. The M24758/14 adapter provides a non-environmental coupling between certain MIL-C-28840 (EC) backshells and the M24758/2, M24758/3 or M24758/4 fittings, specifically, the A-thread of this adapter mates with the V-thread of the M28840/6 backshell (straight), the M28840/8 backshell (90°), or the M28840/9 backshell (45°).
2. Metric dimensions (mm) are indicated in parentheses.
3. For complete dimensions see applicable Military Specification.

M24758/14 Adapter for
MIL-C-28840 (EC) Backshells



Conduit &
Accessories

TABLE I

Conduit Size Code	C Thread (Class 2A)	L ±.02 (.5)	K Dia Min.	N Dia ±.02 (.5)
02	0.438 - 28 UNEF	.210 (5.3)	.250 (6.4)	.687 (17.4)
03	0.563 - 24 UNEF	.250 (6.4)	.370 (9.4)	.812 (20.6)
04	0.688 - 24 UNEF	.250 (6.4)	.500 (12.7)	.937 (23.8)
05	0.813 - 20 UNEF	.310 (7.9)	.620 (15.7)	1.062 (27.0)
06	0.938 - 20 UNEF	.310 (7.9)	.750 (19.1)	1.187 (30.1)
08	1.250 - 18 UNEF	.370 (9.4)	1.000 (25.4)	1.500 (38.1)
10	1.563 - 18 UNEF	.370 (9.4)	1.250 (31.8)	1.812 (46.0)
12	1.875 - 16 UN	.430 (10.9)	1.500 (38.1)	2.125 (54.0)
16	2.375 - 16 UN	.430 (10.9)	2.000 (50.8)	2.625 (66.7)
20	2.875 - 16 UN	.430 (10.9)	2.500 (63.5)	3.125 (79.4)
24	3.375 - 16 UN	.430 (10.9)	3.000 (76.2)	3.625 (92.1)

TABLE II (A Thread Code and Adapter Dimensions)

A Thread Code	Shell Size (Ref.)	A Thread (Class 2B)	D Dia ±.015 (.4)	E Dia ±.015 (.4)
01	B, C	0.625 - 24 UNEF	.875 (22.2)	.435 (11.0)
02	B, C	0.750 - 20 UNEF	1.000 (25.4)	.578 (14.7)
03	C	0.875 - 20 UNEF	1.125 (28.6)	.703 (17.9)
04	D, E	1.000 - 20 UNEF	1.250 (31.8)	.828 (21.0)
05	C, D, F	1.188 - 18 UNEF	1.438 (36.5)	1.000 (25.4)
06	D, E, F, G	1.438 - 18 UNEF	1.688 (42.9)	1.250 (31.8)
07	F, G, H	1.750 - 18 UNS	2.000 (50.8)	1.562 (39.7)
08	G, H, J	2.000 - 18 UNS	2.250 (57.2)	1.813 (46.1)
09	J	2.250 - 16 UN	2.250 (57.2)	2.062 (52.4)
10	C, D, E	1.125 - 18 UNEF	1.375 (34.9)	.938 (23.8)
11	C, D, E, F, G	1.250 - 18 UNEF	1.500 (38.1)	1.078 (27.4)
12	D, E, F, G	1.626 - 18 UNEF	1.875 (47.6)	1.438 (36.5)
13	F, G, H	1.875 - 18 UNS	2.125 (54.0)	1.688 (42.9)
14	G, H, J	2.125 - 16 UN	2.375 (60.3)	1.938 (49.2)
15	J	2.750 - 16 UN	3.000 (76.2)	2.563 (65.1)

**M24758/15 Adapter for
MIL-C-24235 Stuffing Tubes**

M24758/15-B-04-A

Basic Part No.

Stuffing Tube Size Code

Conduit Size Code

Material Designator:

A = Aluminum

B = Brass

C = CRES 316

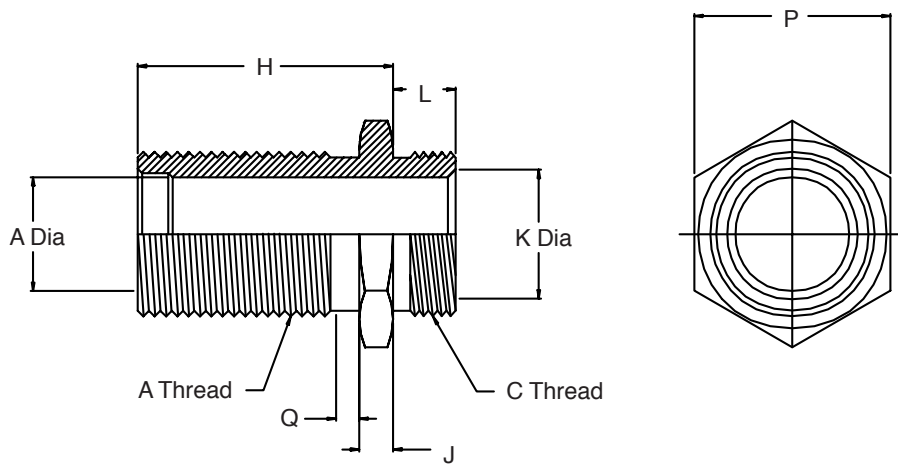

1. The M24758/15 adapter couples MIL-S-24235/9 through MIL-S-24235/17 stuffing tubes to M24758/2, M24758/3, or M24758/4 fittings.
2. Any combination of conduit and stuffing tube sizes may be used by identifying the appropriate conduit size and stuffing tube size in the part number configuration.
3. Metric dimensions (mm) are indicated in parentheses.
4. For complete dimensions see applicable Military Specification.

M24758/15 Adapter for
MIL-C-24235 Stuffing Tubes



Conduit &
Accessories

TABLE I

Conduit Size Code	C Thread (Class 2A)	L ±.02 (.5)	K Dia Min.
02	0.438 - 28 UNEF	.210 (5.3)	.250 (6.4)
03	0.563 - 24 UNEF	.250 (6.4)	.370 (9.4)
04	0.688 - 24 UNEF	.250 (6.4)	.500 (12.7)
05	0.813 - 20 UNEF	.310 (7.9)	.620 (15.7)
06	0.938 - 20 UNEF	.310 (7.9)	.750 (19.1)
08	1.250 - 18 UNEF	.370 (9.4)	1.000 (25.4)
10	1.563 - 18 UNEF	.370 (9.4)	1.250 (31.8)
12	1.875 - 16 UN	.430 (10.9)	1.500 (38.1)
16	2.375 - 16 UN	.430 (10.9)	2.000 (50.8)
20	2.875 - 16 UN	.430 (10.9)	2.500 (63.5)
24	3.375 - 16 UN	.430 (10.9)	3.000 (76.2)

TABLE II

MIL-C-24235 Stuffing Tube Size	Conduit Size Code	A Thread (Class 2A)	A Dia ±.02 (.5)	H ±.02 (.5)	J ±.02 (.5)	P Dim (Minimum)	Q ±.02 (.5)
A	03	0.875 - 12 UN	.406 (10.3)	1.063 (27.0)	.188 (4.8)	1.031 (26.2)	.188 (4.8)
B	04	1.000 - 12 UN	.515 (13.1)	1.063 (27.0)	.188 (4.8)	1.125 (28.6)	.188 (4.8)
C	04,05,06	1.125 - 12 UN	.640 (16.3)	1.063 (27.0)	.188 (4.8)	1.250 (31.8)	.188 (4.8)
D	06	1.250 - 12 UN	.750 (19.1)	1.063 (27.0)	.188 (4.8)	1.375 (34.9)	.188 (4.8)
E	06	1.250 - 12 UN	.812 (20.6)	1.063 (27.0)	.188 (4.8)	1.375 (34.9)	.188 (4.8)
F	08	1.313 - 12 UN	.843 (21.4)	1.188 (30.2)	.188 (4.8)	1.438 (36.5)	.188 (4.8)
G	08	1.500 - 12 UN	.935 (23.7)	1.188 (30.2)	.188 (4.8)	1.656 (42.1)	.188 (4.8)
J	10	1.625 - 12 UN	1.062 (27.0)	1.188 (30.2)	.188 (4.8)	1.781 (45.2)	.188 (4.8)
K	10	1.750 - 12 UN	1.171 (29.7)	1.500 (38.1)	.188 (4.8)	1.875 (47.6)	.188 (4.8)
L	10	1.813 - 12 UN	1.265 (32.1)	1.500 (38.1)	.188 (4.8)	1.938 (49.2)	.188 (4.8)
M	10,12	2.000 - 12 UN	1.406 (35.7)	1.500 (38.1)	.250 (6.4)	2.188 (55.6)	.188 (4.8)
N	12	2.063 - 12 UN	1.515 (38.5)	1.563 (39.7)	.250 (6.4)	2.250 (57.2)	.188 (4.8)
P	16	2.188 - 12 UN	1.625 (41.3)	1.563 (39.7)	.250 (6.4)	2.344 (59.5)	.188 (4.8)
R	16	2.313 - 12 UN	1.750 (44.5)	1.563 (39.7)	.250 (6.4)	2.469 (62.7)	.188 (4.8)
S	16	2.688 - 12 UN	1.875 (47.6)	2.188 (55.6)	.313 (8.0)	2.813 (71.5)	.250 (6.4)
T	16	2.875 - 12 UN	2.062 (52.4)	2.188 (55.6)	.313 (8.0)	2.969 (75.4)	.250 (6.4)
V	16	3.000 - 12 UN	2.187 (55.5)	2.188 (55.6)	.313 (8.0)	3.094 (78.6)	.250 (6.4)
W	16,20	3.125 - 12 UN	2.312 (58.7)	2.188 (55.6)	.313 (8.0)	3.281 (83.3)	.250 (6.4)
X	20	3.250 - 12 UN	2.500 (63.5)	2.188 (55.6)	.313 (8.0)	3.438 (87.3)	.250 (6.4)
Y	20	3.375 - 12 UN	2.609 (66.3)	2.188 (55.6)	.313 (8.0)	3.563 (90.5)	.250 (6.4)
Z	20	3.563 - 12 UN	2.781 (70.6)	2.188 (55.6)	.313 (8.0)	3.750 (95.3)	.250 (6.4)
AA	20,24	3.750 - 12 UN	2.875 (73.0)	3.125 (79.4)	.438 (11.1)	3.875 (98.4)	.250 (6.4)
BB	24	4.000 - 12 UN	3.157 (80.2)	3.125 (79.4)	.438 (11.1)	4.125 (104.8)	.250 (6.4)

M24758/16 Adapter for Miscellaneous Fittings

M24758/16-16-04-A

Basic Part No. _____
 Conduit Size Code _____
 (See Table I)
 A-Thread Code _____
 (See Table II)

Material Designator:
 A = Aluminum
 B = Brass
 C = CRES 316

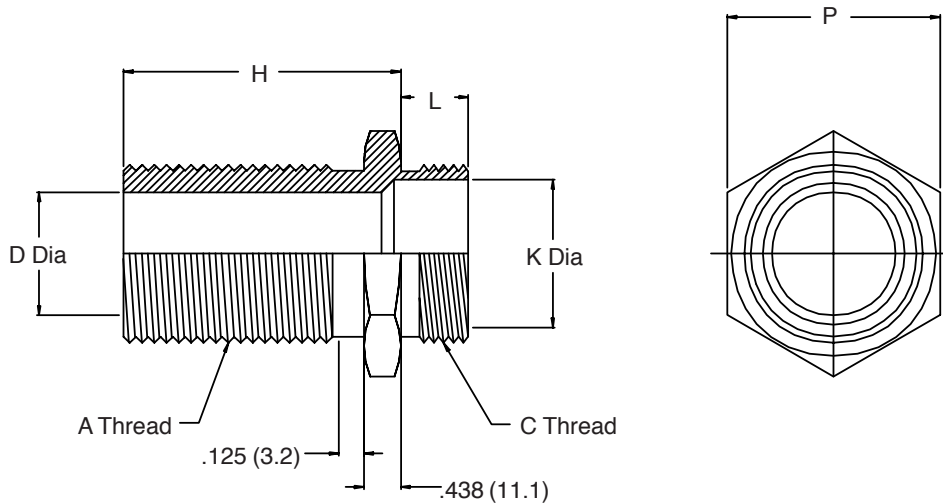

1. The M24758/16 adapter couples miscellaneous fittings to M24758/2, M24758/3, or M24758/4 fittings.
2. The American National Thread Series (N) has been superseded by the Unified Thread Series (UN). The series N-thread sizes listed in table II are retained for use with those items which have series N-threads.
3. Metric dimensions (mm) are indicated in parentheses.
4. For complete dimensions see applicable Military Specification.

M24758/16 Adapter for Miscellaneous Fittings



Conduit & Accessories

TABLE I

Conduit Size Code	C Thread (Class 2A)	L ±.02 (.5)	K Dia Min.
02	0.438 - 28 UNEF	.210 (5.3)	.250 (6.4)
03	0.563 - 24 UNEF	.250 (6.4)	.370 (9.4)
04	0.688 - 24 UNEF	.250 (6.4)	.500 (12.7)
05	0.813 - 20 UNEF	.310 (7.9)	.620 (15.7)
06	0.938 - 20 UNEF	.310 (7.9)	.750 (19.1)
08	1.250 - 18 UNEF	.370 (9.4)	1.000 (25.4)
10	1.563 - 18 UNEF	.370 (9.4)	1.250 (31.8)
12	1.875 - 16 UN	.430 (10.9)	1.500 (38.1)
16	2.375 - 16 UN	.430 (10.9)	2.000 (50.8)
20	2.875 - 16 UN	.430 (10.9)	2.500 (63.5)
24	3.375 - 16 UN	.430 (10.9)	3.000 (76.2)

TABLE II (A Thread Code and Adapter Dimensions)

A Thread Code	A Thread (Class 2A)	D Dia ±.005 (.4)	H Dim. ±.02 (.5)	p Dim. Min.
01	1.125 - 14 N	.500 (12.7)	1.250 (31.8)	1.250 (31.8)
03	1.288 - 14N	.750 (19.1)	1.250 (31.8)	1.430 (36.3)
04	0.750 - 14 NPSM	.750 (19.1)	1.250 (31.8)	1.370 (34.8)
06	1.000 - 11 1/2 NPSM	1.000 (25.4)	1.250 (31.8)	1.680 (42.7)
07	1.250 - 11 1/2 NPSM	1.000 (25.4)	1.250 (31.8)	1.810 (46.0)
09	1.250 - 11 1/2 NPSM	1.180 (30.0)	1.250 (31.8)	1.810 (46.0)
10	2.025 - 11 1/2 N	1.250 (31.8)	1.560 (39.6)	2.180 (55.4)
13	2.250 - 11 1/2 N	1.500 (38.1)	1.690 (42.9)	2.500 (63.5)
16	2.500 - 8 NPSM	2.000 (50.8)	2.000 (50.8)	3.000 (76.2)
19	3.000 - 8 NPSM	2.500 (63.5)	2.060 (52.3)	3.620 (91.9)
20	1.500 - 11 1/2 NPSM	1.500 (38.1)	1.250 (31.8)	2.500 (63.5)
21	2.000 - 11 1/2 NPSM	2.000 (50.8)	1.250 (31.8)	3.000 (76.2)

M24758/17 Adapter for Tapered Pipe Thread

M24758/17-16-A

Basic Part No.

Conduit Size Code
(See Table I)

Material Designator:

A = Aluminum
B = Brass
C = CRES 316

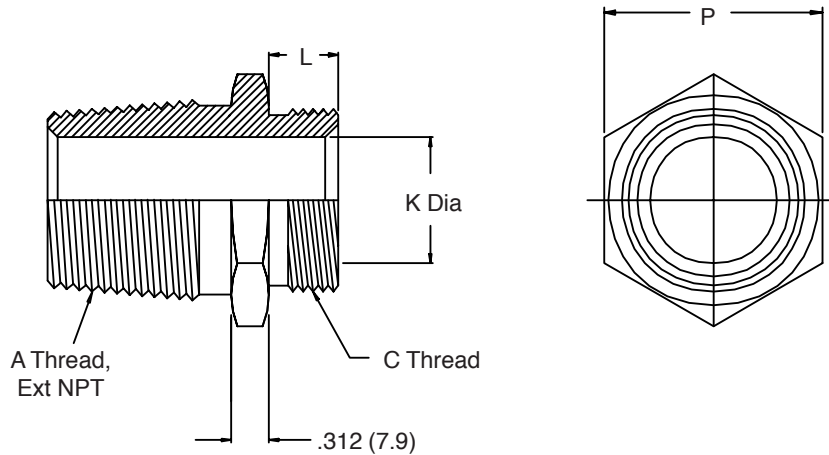

TABLE I

Conduit Size Code	A Thread	P Dia (Minimum)	C Thread (Class 2A)	L ±.02 (.5)	K Dia Min.
02	0.250 - 18.00 NPT	.690 (17.5)	0.438 - 28 UNEF	.210 (5.3)	.250 (6.4)
03	0.375 - 18.00 NPT	.810 (20.6)	0.563 - 24 UNEF	.250 (6.4)	.370 (9.4)
04	0.500 - 14.00 NPT	1.000 (25.4)	0.688 - 24 UNEF	.250 (6.4)	.500 (12.7)
05	0.750 - 14.00 NPT	1.180 (30.0)	0.813 - 20 UNEF	.310 (7.9)	.620 (15.7)
06	0.750 - 14.00 NPT	1.180 (30.0)	0.938 - 20 UNEF	.310 (7.9)	.750 (19.1)
08	1.000 - 11.50 NPT	1.500 (38.1)	1.250 - 18 UNEF	.370 (9.4)	1.000 (25.4)
10	1.250 - 11.50 NPT	1.810 (46.0)	1.563 - 18 UNEF	.370 (9.4)	1.250 (31.8)
12	1.500 - 11.50 NPT	2.120 (53.8)	1.875 - 16 UN	.430 (10.9)	1.500 (38.1)
16	2.000 - 11.50 NPT	2.620 (66.5)	2.375 - 16 UN	.430 (10.9)	2.000 (50.8)
20	2.500 - 8.00 NPT	3.000 (76.2)	2.875 - 16 UN	.430 (10.9)	2.500 (63.5)
24	3.000 - 8.00 NPT	3.620 (91.9)	3.375 - 16 UN	.430 (10.9)	3.000 (76.2)

1. The M24758/17 adapter couples any fittings having a female tapered pipe thread to M24758/2, M24758/3, or M24758/4 fittings.
2. Metric dimensions (mm) are indicated in parentheses.
3. For complete dimensions see applicable Military Specification.

M24758/18 Adapter for Straight Pipe Thread



Conduit & Accessories

M24758/18-16-A

Basic Part No.

Conduit Size Code
(See Table I)

Material Designator:

A = Aluminum

B = Brass

C = CRES 316

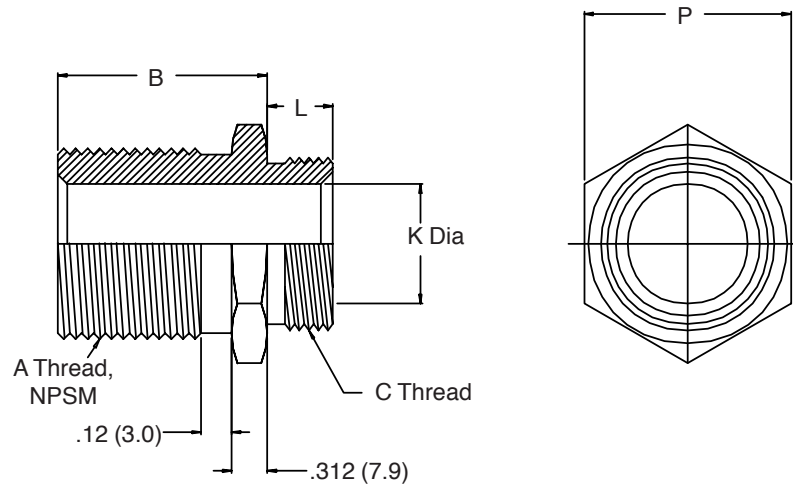

TABLE I

Conduit Size Code	A Pipe Thread	B Dim. ±.02 (.5)	P Dia (Minimum)	C Thread (Class 2A)	L ±.02 (.5)	K Dia Min.
02	0.250 - 18.00 NPSM	.750 (19.1)	.690 (17.5)	0.438 - 28 UNEF	.210 (5.3)	.250 (6.4)
03	0.375 - 18.00 NPSM	.750 (19.1)	.810 (20.6)	0.563 - 24 UNEF	.250 (6.4)	.370 (9.4)
04	0.500 - 14.00 NPSM	.870 (22.1)	1.000 (25.4)	0.688 - 24 UNEF	.250 (6.4)	.500 (12.7)
05	0.750 - 14.00 NPSM	.870 (22.1)	1.180 (30.0)	0.813 - 20 UNEF	.310 (7.9)	.620 (15.7)
06	0.750 - 14.00 NPSM	.870 (22.1)	1.180 (30.0)	0.938 - 20 UNEF	.310 (7.9)	.750 (19.1)
08	1.000 - 11.50 NPSM	.870 (22.1)	1.500 (38.1)	1.250 - 18 UNEF	.370 (9.4)	1.000 (25.4)
10	1.250 - 11.50 NPSM	.870 (22.1)	1.810 (46.0)	1.563 - 18 UNEF	.370 (9.4)	1.250 (31.8)
12	1.500 - 11.50 NPSM	1.000 (25.4)	2.120 (53.8)	1.875 - 16 UN	.430 (10.9)	1.500 (38.1)
16	2.000 - 11.50 NPSM	1.190 (30.2)	2.620 (66.5)	2.375 - 16 UN	.430 (10.9)	2.000 (50.8)
20	2.500 - 8.00 NPSM	1.620 (41.1)	3.000 (76.2)	2.875 - 16 UN	.430 (10.9)	2.500 (63.5)
24	3.000 - 8.00 NPSM	1.690 (42.9)	3.620 (91.9)	3.375 - 16 UN	.430 (10.9)	3.000 (76.2)

1. The M24758/18 adapter couples any fittings having a female straight pipe thread to M24758/2, M24758/3, or M24758/4 fittings.
2. Metric dimensions (mm) are indicated in parentheses.
3. For complete dimensions see applicable Military Specification.

M24758/19 Adapter for Panel Termination

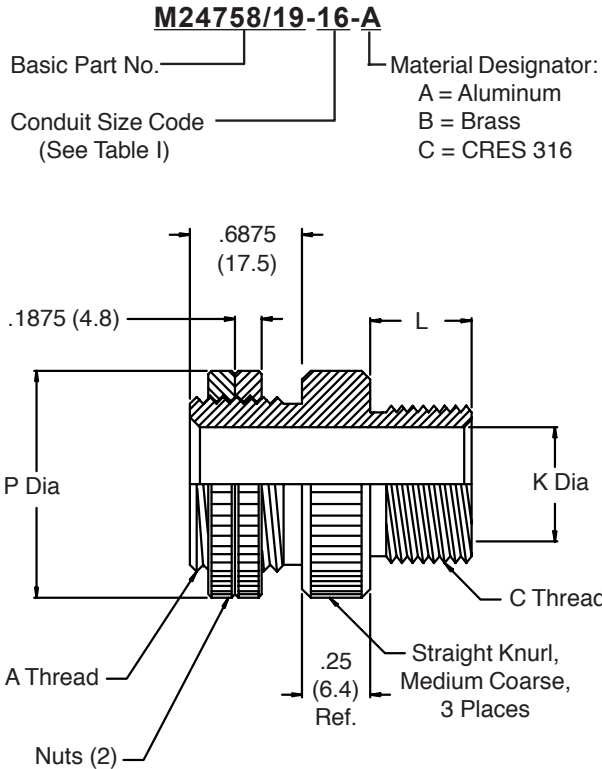

TABLE I

Conduit Size Code	A Thread (Class 2A)	P Dia Min.	C Thread (Class 2A)	L ±.02 (.5)	K Dia Min.
02	0.625 - 24 UNEF	.870 (22.1)	0.438 - 28 UNEF	.210 (5.3)	.250 (6.4)
03	0.750 - 20 UNEF	1.000 (25.4)	0.563 - 24 UNEF	.250 (6.4)	.370 (9.4)
04	0.875 - 20 UNEF	1.120 (28.4)	0.688 - 24 UNEF	.250 (6.4)	.500 (12.7)
05	1.000 - 20 UNEF	1.250 (31.8)	0.813 - 20 UNEF	.310 (7.9)	.620 (15.7)
06	1.188 - 18 UNEF	1.430 (36.3)	0.938 - 20 UNEF	.310 (7.9)	.750 (19.1)
08	1.438 - 18 UNEF	1.680 (42.7)	1.250 - 18 UNEF	.370 (9.4)	1.000 (25.4)
10	1.750 - 16 UN	2.000 (50.8)	1.563 - 18 UNEF	.370 (9.4)	1.250 (31.8)
12	2.000 - 16 UN	2.250 (57.2)	1.875 - 16 UN	.430 (10.9)	1.500 (38.1)
16	2.500 - 16 UN	3.000 (76.2)	2.375 - 16 UN	.430 (10.9)	2.000 (50.8)
20	3.000 - 16 UN	3.500 (88.9)	2.875 - 16 UN	.430 (10.9)	2.500 (63.5)
24	3.500 - 16 UN	4.000 (101.6)	3.375 - 16 UN	.430 (10.9)	3.000 (76.2)

1. The M24758/19 adapter provides the capability of terminating a M24758/2, M24758/3, or M24758/4 fitting to a panel.
2. Metric dimensions (mm) are indicated in parentheses.
3. For complete dimensions see applicable Military Specification.

M28840/4 Metal Core Conduit for EMI Shielding



Conduit & Accessories

M28840/4-10-A C

Basic Part No. ————
 Conduit Size Code ————
 Type Designator: ————

Material Designator
 C = Brass Conduit with Low Phosphorous
 Bronze Wire Braid and Neoprene Jacket
 E = Nickel-Iron Conduit with Tinned Coated
 Copper Braid and Neoprene Jacket

A = Plain
 B = Insulator Jacket

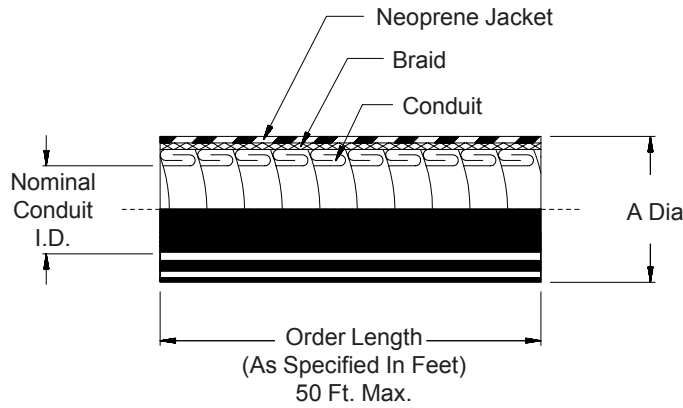

Conduit Size Code	Nominal Conduit I.D.	A Dia
03	.375 (9.5)	.525 (13.3)
04	.500 (12.7)	.650 (16.5)
05	.625 (15.9)	.765 (19.4)
06	.750 (19.1)	.925 (23.5)
08	1.000 (25.4)	1.210 (30.7)
10	1.250 (31.8)	1.455 (37.0)
12	1.500 (38.1)	1.725 (43.8)
16	2.000 (50.8)	2.200 (55.9)

1. Metric dimensions (mm) are indicated in parentheses.
2. For complete dimensions see applicable Military Specification.

M28840/5 Metal Conduit Backshell

Glenair Connector
Designator G

MIL-C-28840

M28840/5 16 W A

Basic Part No. _____

Dash No. _____

Material and Finish _____

W = Aluminum, Cadmium Plate,
Olive Drab over Electroless Nickel
D = CRES 316, Cadmium Plate, Black

Style Designator:
A = EMI/Non-Environmental
B = EMI/Environmental

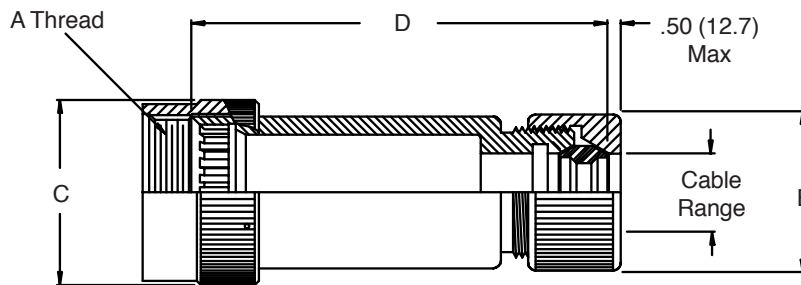

**STYLE A - EMI/Non-Environmental
(Plain Conduit)**

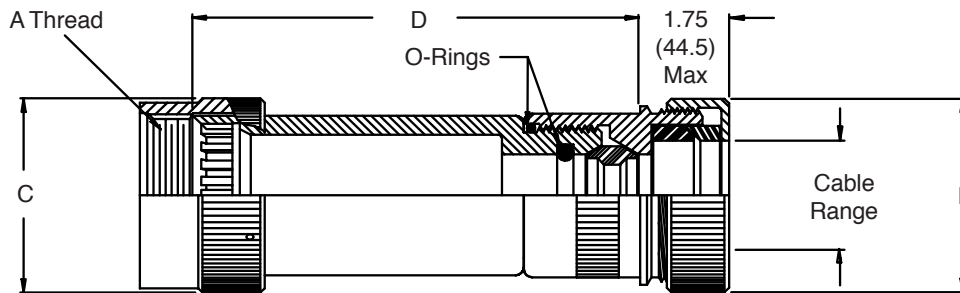

**STYLE B - EMI/Environmental
(Jacket Conduit)**

**M28840/5
Metal Conduit Backshell**



Conduit &
Accessories

TABLE I

Shell Size	A Thread Class 2B	C Dia Max
A (11)	.750 - 20 UNEF	1.028 (26.1)
B (13)	.875 - 20 UNEF	1.141 (29.0)
C (15)	1.000 - 20 UNEF	1.263 (32.1)
D (17)	1.125 - 18 UNEF	1.387 (35.2)
E (19)	1.250 - 18 UNEF	1.513 (38.4)
F (23)	1.438 - 18 UNEF	1.703 (43.3)
G (25)	1.562 - 18 UNEF	1.825 (46.4)
H (29)	1.875 - 16 UN	2.143 (54.4)
J (33)	2.062 - 16 UNS	2.329 (59.2)

TABLE II

Dash No.	Shell Size Desig.	D Dia		E Max Dia	F Max Dia	Cable Range					
		±.12	(3.1)			Min	Max	Min	Max		
01	A (11)	1.75	(44.5)	1.12	(28.4)	1.19	(30.2)	.50	(12.7)	.63	(16.0)
02	B (13)	1.75	(44.5)	1.12	(28.4)	1.19	(30.2)	.50	(12.7)	.63	(16.0)
03	B (13)	1.75	(44.5)	1.25	(31.8)	1.38	(35.1)	.63	(16.0)	.75	(19.1)
04	C (15)	1.75	(44.5)	1.12	(28.4)	1.19	(30.2)	.50	(12.7)	.63	(16.0)
05	C (15)	1.75	(44.5)	1.25	(31.8)	1.38	(35.1)	.63	(16.0)	.75	(19.1)
06	C (15)	1.75	(44.5)	1.43	(36.3)	1.63	(41.4)	.75	(19.1)	.88	(22.4)
07	C (15)	3.00	(76.2)	1.62	(41.1)	1.94	(49.3)	.88	(22.4)	1.00	(25.4)
08	D (17)	2.25	(57.2)	1.43	(36.3)	1.63	(41.4)	.75	(19.1)	.88	(22.4)
09	D (17)	2.25	(57.2)	1.62	(41.1)	1.94	(49.3)	.88	(22.4)	1.00	(25.4)
10	D (17)	2.25	(57.2)	1.81	(46.0)	2.19	(55.6)	1.19	(30.2)	1.38	(35.1)
11	E (19)	2.25	(57.2)	1.43	(36.3)	1.63	(41.4)	.75	(19.1)	.88	(22.4)
12	E (19)	2.25	(57.2)	1.62	(41.1)	1.94	(49.3)	.88	(22.4)	1.00	(25.4)
13	E (19)	2.25	(57.2)	1.81	(46.0)	2.19	(55.6)	1.19	(30.2)	1.38	(35.1)
14	F (23)	2.75	(69.9)	1.62	(41.1)	1.94	(49.3)	.88	(22.4)	1.00	(25.4)
15	F (23)	2.75	(69.9)	1.81	(46.0)	2.19	(55.6)	1.19	(30.2)	1.38	(35.1)
16	F (23)	3.50	(88.9)	2.18	(55.4)	2.44	(62.0)	1.44	(36.6)	1.63	(41.4)
17	G (25)	2.75	(69.9)	1.62	(41.1)	1.94	(49.3)	.88	(22.4)	1.00	(25.4)
18	G (25)	2.75	(69.9)	1.81	(46.0)	2.19	(55.6)	1.19	(30.2)	1.38	(35.1)
19	G (25)	2.75	(69.9)	2.18	(55.4)	2.44	(62.0)	1.44	(36.6)	1.63	(41.4)
20	G (25)	4.00	(101.6)	2.56	(65.0)	2.69	(68.3)	1.63	(41.4)	1.88	(47.8)
21	H (29)	3.25	(82.6)	2.18	(55.4)	2.44	(62.0)	1.44	(36.6)	1.63	(41.4)
22	H (29)	3.25	(82.6)	2.55	(64.8)	2.69	(68.3)	1.63	(41.4)	1.88	(47.8)
23	J (33)	3.25	(82.6)	2.56	(65.0)	2.69	(68.3)	1.63	(41.4)	1.88	(47.8)
24	J (33)	3.25	(82.6)	3.06	(77.7)	3.19	(81.0)	2.13	(54.1)	2.38	(60.5)
25	A (11)	1.75	(44.5)	1.25	(31.8)	1.38	(35.1)	.63	(16.0)	.75	(19.1)

1. Metric dimensions (mm) are indicated in parentheses.
2. For complete dimensions see applicable Military Specification.

Conduit comes in all shapes and sizes (and materials).

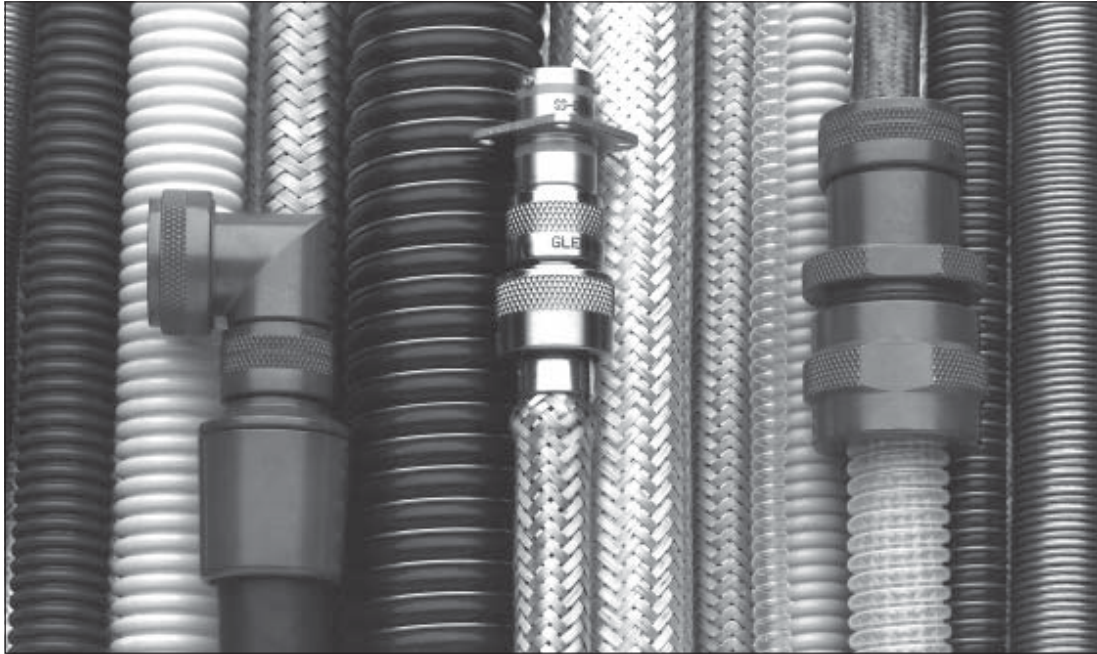

And nobody offers a broader range of options than Glenair.

From the interconnection of laboratory test equipment to above-deck ship-board use, our plastic convoluted tubing and metal-core conduit provide outstanding wiring protection and shielding. We've designed our product line to satisfy virtually every application specification by

offering the widest range of materials in the industry: PTFE, Tefzel, PFA, FEP, Kynar, PEEK, brass, nickel-iron, and stainless steel - with overbraided shielding in tin copper, nickel copper, Aracon, phosphorous bronze, stainless steel, Halar, Nomex, Dacron, and Kevlar.



Annular & helical convoluted tubing



Metal-core conduit & a full range of shields & jackets



Metal or composite fittings and transitions



User-serviceable conduit systems



MIL-C-24758 fittings and adapters



Complete custom-designed conduit assemblies



1211 Air Way
Glendale, California 91201-2497
Telephone: 818-247-6000 · Facsimilie: 818-500-9912 · EMail: sales@glenair.com

United States · United Kingdom · Germany · Scandinavia · France · Italy · Spain

www.glenair.com

M28840/22 Metal Conduit Bushing



Conduit &
Accessories

M28840/22-S 10

Basic Part No. _____ Dash No. (See Table I)

Material Designator _____

S = Corrosion Resistant Steel
Passivate per QQ-P-35

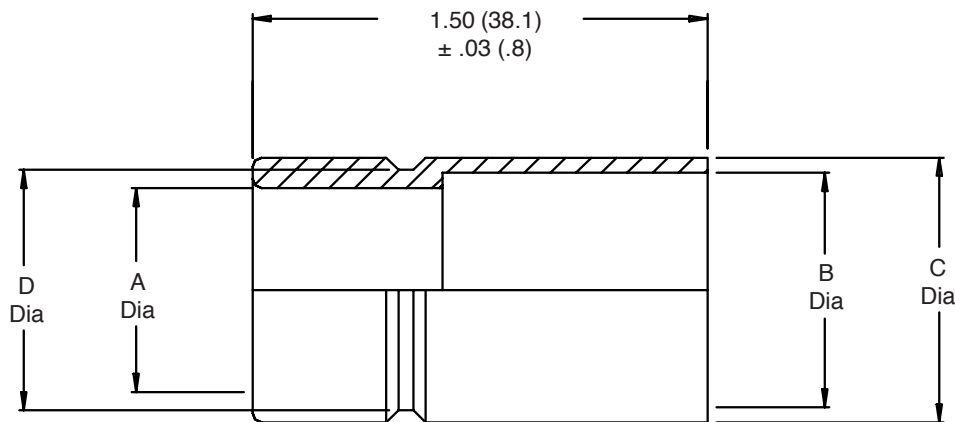

TABLE I									
M28840/4		A Dia		B Dia		C Dia		D	
Size	Size Ref.	+0.020 -.000	(.5) (.0)	+0.005 -.000	(.12) (.0)	+0.000 -.005	(.0) (.12)	+0.000 -.005	(.0) (.12)
03	03	.375	(9.5)	.540	(13.7)	.625	(15.9)	.525	(13.3)
04	04	.500	(12.7)	.665	(16.9)	.750	(19.1)	.650	(16.5)
05	05	.625	(15.9)	.780	(19.8)	.875	(22.2)	.775	(19.7)
06	06	.750	(19.1)	.940	(23.9)	1.000	(25.4)	.900	(22.9)
08	08	1.000	(25.4)	1.225	(31.1)	1.375	(34.9)	1.275	(32.4)
10	10	1.250	(31.8)	1.470	(37.3)	1.625	(41.3)	1.525	(38.7)
12	12	1.500	(38.1)	1.740	(44.2)	1.875	(47.6)	1.775	(45.1)
16	16	2.000	(50.8)	2.215	(56.3)	2.375	(60.3)	2.275	(57.8)

1. For complete dimensions see applicable Military Specification.
2. Metric dimensions (mm) are indicated in parentheses.

M28840/25 EMI Adapters for M28840 Connectors

Glenair Connector
Designator G

MIL-C-28840

M28840/25 16 W A

Basic Part No.

Dash No. (Table I)

Material and Finish

W = Aluminum, Cadmium Plate,
Olive Drab over Electroless Nickel
D = CRES 316, Cadmium Plate, Black

Style Designator:

A = EMI/Non-Environmental
B = EMI/Environmental

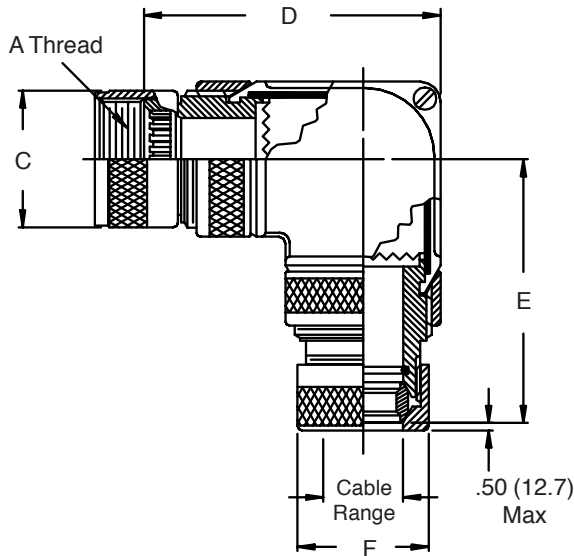

**STYLE A - EMI/Non-Environmental
(Plain Conduit)**

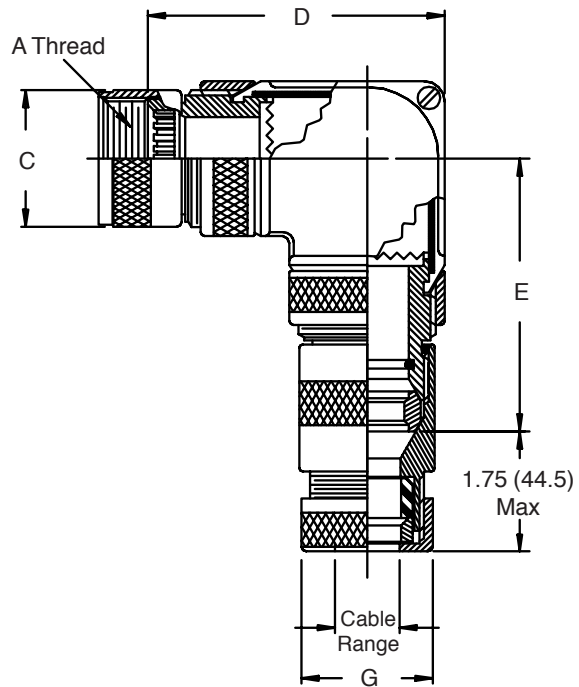

**STYLE B - EMI/Environmental
(Jacket Conduit)**

1. For complete dimensions see applicable Military Specification.
2. Metric dimensions (mm) are indicated in parentheses.

M28840/25 EMI Adapters
for M28840 Connectors



Conduit &
Accessories

TABLE I

Dash No.	Shell Size (Table II)	D Max Dim	E Max Dim	F Max Dia	G Max Dia	Cable Range		Conduit Size *
						Max	Min	
1	11	2.36 (59.9)	3.50 (88.9)	1.12 (28.4)	1.19 (30.2)	.63 (16.0)	.50 (12.7)	03
2	13	2.36 (59.9)	3.50 (88.9)	1.12 (28.4)	1.19 (30.2)	.63 (16.0)	.50 (12.7)	03
3	13	2.36 (59.9)	3.50 (88.9)	1.25 (31.8)	1.38 (35.1)	.75 (19.1)	.63 (16.0)	04
4	15	2.56 (65.0)	3.69 (93.7)	1.12 (28.4)	1.19 (30.2)	.63 (16.0)	.50 (12.7)	03
5	15	2.56 (65.0)	3.69 (93.7)	1.25 (31.8)	1.38 (35.1)	.75 (19.1)	.63 (16.0)	04
6	15	2.56 (65.0)	3.69 (93.7)	1.43 (36.3)	1.63 (41.4)	.88 (22.4)	.75 (19.1)	05
7	15	2.67 (67.8)	3.81 (96.8)	1.62 (41.1)	1.94 (49.3)	1.00 (25.4)	.88 (22.4)	06
8	17	2.67 (67.8)	3.81 (96.8)	1.43 (36.3)	1.63 (41.4)	.88 (22.4)	.75 (19.1)	05
9	17	2.67 (67.8)	3.81 (96.8)	1.62 (41.1)	1.94 (49.3)	1.00 (25.4)	.88 (22.4)	06
10	17	2.67 (67.8)	3.81 (96.8)	1.81 (46.0)	2.19 (55.6)	1.38 (35.1)	1.19 (30.2)	08
11	19	2.67 (67.8)	3.81 (96.8)	1.43 (36.3)	1.63 (41.4)	.88 (22.4)	.75 (19.1)	05
12	19	2.67 (67.8)	3.81 (96.8)	1.62 (41.1)	1.94 (49.3)	1.00 (25.4)	.88 (22.4)	06
13	19	3.05 (77.5)	4.19 (106.4)	1.81 (46.0)	2.19 (55.6)	1.38 (35.1)	1.19 (30.2)	08
14	23	3.05 (77.5)	4.19 (106.4)	1.62 (41.1)	1.94 (49.3)	1.00 (25.4)	.88 (22.4)	06
15	23	3.05 (77.5)	4.19 (106.4)	1.81 (46.0)	2.19 (55.6)	1.38 (35.1)	1.19 (30.2)	08
16	23	3.05 (77.5)	4.19 (106.4)	2.18 (55.4)	2.44 (62.0)	1.63 (41.4)	1.44 (36.6)	10
17	25	3.05 (77.5)	4.19 (106.4)	1.62 (41.1)	1.94 (49.3)	1.00 (25.4)	.88 (22.4)	06
18	25	3.05 (77.5)	4.19 (106.4)	1.81 (46.0)	2.19 (55.6)	1.38 (35.1)	1.19 (30.2)	08
19	25	3.05 (77.5)	4.19 (106.4)	2.18 (55.4)	2.44 (62.0)	1.63 (41.4)	1.44 (36.6)	10
20	25	3.33 (84.6)	4.50 (114.3)	2.56 (65.0)	2.69 (68.3)	1.88 (47.8)	1.63 (41.4)	12
21	29	3.33 (84.6)	4.50 (114.3)	2.18 (55.4)	2.44 (62.0)	1.63 (41.4)	1.44 (36.6)	10
22	29	3.33 (84.6)	4.50 (114.3)	2.56 (65.0)	2.69 (68.3)	1.88 (47.8)	1.63 (41.4)	12
23	33	3.70 (94.0)	4.83 (122.7)	2.56 (65.0)	2.69 (68.3)	1.88 (47.8)	1.63 (41.4)	12
24	33	3.70 (94.0)	4.83 (122.7)	3.06 (77.7)	3.19 (81.0)	2.38 (60.5)	2.13 (54.1)	16
25	11	2.36 (59.9)	3.50 (88.9)	1.25 (31.8)	1.38 (35.1)	.75 (19.1)	.63 (16.0)	04

* Conduit Size of M28840/4 Conduit (Page 71-31)

TABLE II

Shell Size	A Thread Class 2B	C Dia Max
11	.750 - 20 UNEF	1.028 (26.1)
13	.875 - 20 UNEF	1.141 (29.0)
15	1.000 - 20 UNEF	1.263 (32.1)
17	1.125 - 18 UNEF	1.387 (35.2)
19	1.250 - 18 UNEF	1.513 (38.4)
23	1.438 - 18 UNEF	1.703 (43.3)
25	1.562 - 18 UNEF	1.825 (46.4)
29	1.875 - 16 UN	2.143 (54.4)
33	2.062 - 16 UNS	2.329 (59.2)

M28840/27 EMI Adapters for M28840 Connectors

Glenair Connector
Designator G

MIL-C-28840

M28840/27 16 W A

Basic Part No.

Dash No. (Table I)

Material and Finish

W = Aluminum, Cadmium Plate,
Olive Drab over Electroless Nickel
D = CRES 316, Cadmium Plate, Black

Style Designator:

A = EMI/Non-Environmental
B = EMI/Environmental

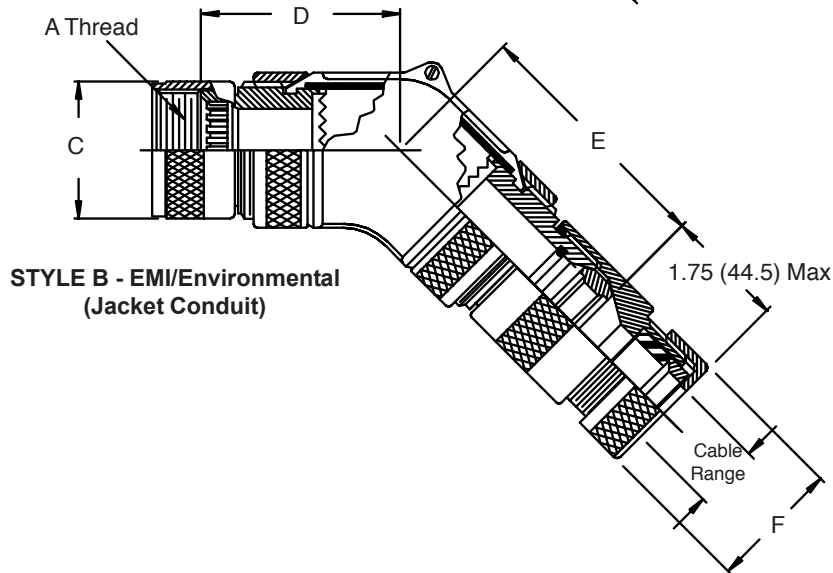
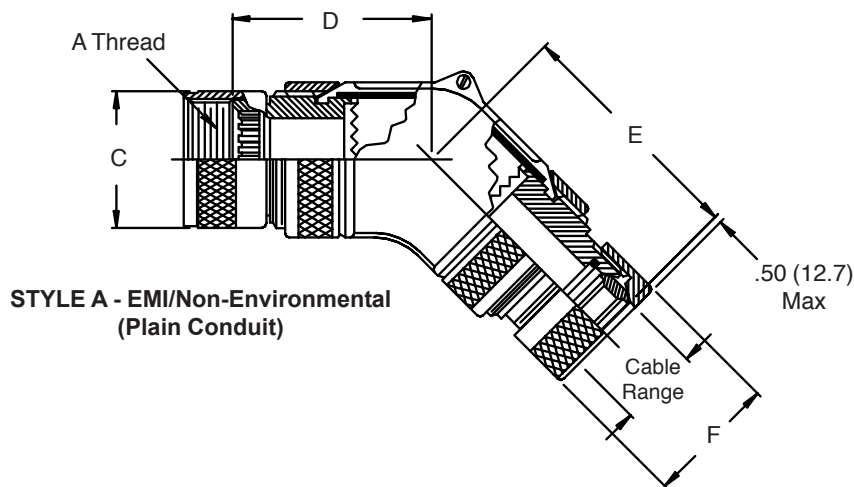

M28840/27 EMI Adapters
for M28840 Connectors



Conduit &
Accessories

TABLE I

Dash No.	Shell Size (Table II)	D Max Dim	E Max Dim	F Max Dia	G Max Dia	Cable Range		Conduit Size *
						Max	Min	
1	11	2.36 (59.9)	3.50 (88.9)	1.12 (28.4)	1.19 (30.2)	.63 (16.0)	.50 (12.7)	03
2	13	2.36 (59.9)	3.50 (88.9)	1.12 (28.4)	1.19 (30.2)	.63 (16.0)	.50 (12.7)	03
3	13	2.36 (59.9)	3.50 (88.9)	1.25 (31.8)	1.38 (35.1)	.75 (19.1)	.63 (16.0)	04
4	15	2.56 (65.0)	3.69 (93.7)	1.12 (28.4)	1.19 (30.2)	.63 (16.0)	.50 (12.7)	03
5	15	2.56 (65.0)	3.69 (93.7)	1.25 (31.8)	1.38 (35.1)	.75 (19.1)	.63 (16.0)	04
6	15	2.56 (65.0)	3.69 (93.7)	1.43 (36.3)	1.63 (41.4)	.88 (22.4)	.75 (19.1)	05
7	15	2.67 (67.8)	3.81 (96.8)	1.62 (41.1)	1.94 (49.3)	1.00 (25.4)	.88 (22.4)	06
8	17	2.67 (67.8)	3.81 (96.8)	1.43 (36.3)	1.63 (41.4)	.88 (22.4)	.75 (19.1)	05
9	17	2.67 (67.8)	3.81 (96.8)	1.62 (41.1)	1.94 (49.3)	1.00 (25.4)	.88 (22.4)	06
10	17	2.67 (67.8)	3.81 (96.8)	1.81 (46.0)	2.19 (55.6)	1.38 (35.1)	1.19 (30.2)	08
11	19	2.67 (67.8)	3.81 (96.8)	1.43 (36.3)	1.63 (41.4)	.88 (22.4)	.75 (19.1)	05
12	19	2.67 (67.8)	3.81 (96.8)	1.62 (41.1)	1.94 (49.3)	1.00 (25.4)	.88 (22.4)	06
13	19	3.05 (77.5)	4.19 (106.4)	1.81 (46.0)	2.19 (55.6)	1.38 (35.1)	1.19 (30.2)	08
14	23	3.05 (77.5)	4.19 (106.4)	1.62 (41.1)	1.94 (49.3)	1.00 (25.4)	.88 (22.4)	06
15	23	3.05 (77.5)	4.19 (106.4)	1.81 (46.0)	2.19 (55.6)	1.38 (35.1)	1.19 (30.2)	08
16	23	3.05 (77.5)	4.19 (106.4)	2.18 (55.4)	2.44 (62.0)	1.63 (41.4)	1.44 (36.6)	10
17	25	3.05 (77.5)	4.19 (106.4)	1.62 (41.1)	1.94 (49.3)	1.00 (25.4)	.88 (22.4)	06
18	25	3.05 (77.5)	4.19 (106.4)	1.81 (46.0)	2.19 (55.6)	1.38 (35.1)	1.19 (30.2)	08
19	25	3.05 (77.5)	4.19 (106.4)	2.18 (55.4)	2.44 (62.0)	1.63 (41.4)	1.44 (36.6)	10
20	25	3.33 (84.6)	4.50 (114.3)	2.56 (65.0)	2.69 (68.3)	1.88 (47.8)	1.63 (41.4)	12
21	29	3.33 (84.6)	4.50 (114.3)	2.18 (55.4)	2.44 (62.0)	1.63 (41.4)	1.44 (36.6)	10
22	29	3.33 (84.6)	4.50 (114.3)	2.56 (65.0)	2.69 (68.3)	1.88 (47.8)	1.63 (41.4)	12
23	33	3.70 (94.0)	4.83 (122.7)	2.56 (65.0)	2.69 (68.3)	1.88 (47.8)	1.63 (41.4)	12
24	33	3.70 (94.0)	4.83 (122.7)	3.06 (77.7)	3.19 (81.0)	2.38 (60.5)	2.13 (54.1)	16
25	11	2.36 (59.9)	3.50 (88.9)	1.25 (31.8)	1.38 (35.1)	.75 (19.1)	.63 (16.0)	04

* Conduit Size of M28840/4 Conduit (Page 71-31)

TABLE II

Shell Size	A Thread Class 2B	C Dia Max
11	.750 - 20 UNEF	1.028 (26.1)
13	.875 - 20 UNEF	1.141 (29.0)
15	1.000 - 20 UNEF	1.263 (32.1)
17	1.125 - 18 UNEF	1.387 (35.2)
19	1.250 - 18 UNEF	1.513 (38.4)
23	1.438 - 18 UNEF	1.703 (43.3)
25	1.562 - 18 UNEF	1.825 (46.4)
29	1.875 - 16 UN	2.143 (54.4)
33	2.062 - 16 UNS	2.329 (59.2)

1. For complete dimensions see applicable Military Specification.
2. Metric dimensions (mm) are indicated in parentheses.

M28840/30 Metal Conduit Coupling

MIL-C-28840

M28840/30-16 W A

Basic Part No. _____

Dash No. _____

Material and Finish _____

W = Aluminum, Cadmium Plate,
Olive Drab over Electroless Nickel
D = CRES 316, Cadmium Plate, Black

Style Designator:
A = EMI/Non-Environmental
B = EMI/Environmental

STYLE A
EMI/Non-Environmental
(Plain Conduit)

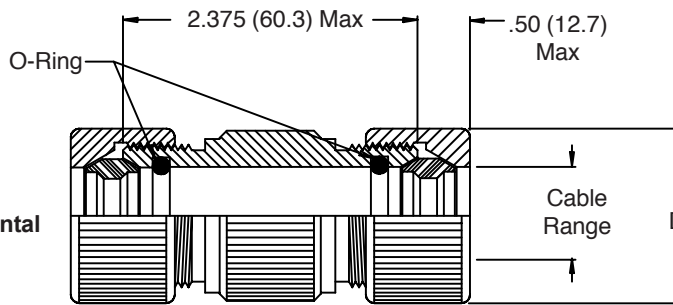

STYLE B
EMI/Environmental
(Jacket Conduit)

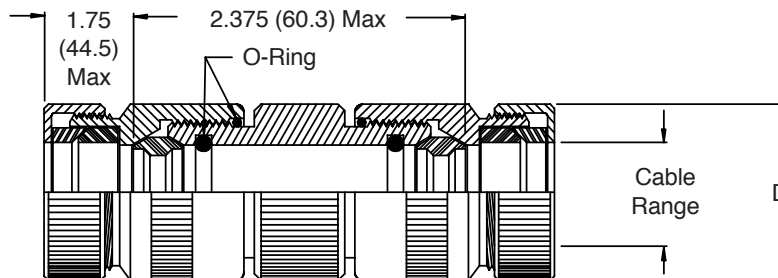

TABLE I

Dash No./ Conduit Size	D Max Dia	E Max Dia	Cable Range	
			Max	Min
03	1.12 (28.4)	1.19 (30.2)	.63 (16.0)	.50 (12.7)
04	1.25 (31.8)	1.38 (35.1)	.75 (19.1)	.63 (16.0)
05	1.43 (36.3)	1.63 (41.4)	.88 (22.4)	.75 (19.1)
06	1.62 (41.1)	1.94 (49.3)	1.00 (25.4)	.88 (22.4)
08	1.81 (46.0)	2.19 (55.6)	1.38 (35.1)	1.19 (30.2)
10	2.18 (55.4)	2.44 (62.0)	1.63 (41.4)	1.44 (36.6)
12	2.56 (65.0)	2.69 (68.3)	1.88 (47.8)	1.63 (41.4)
16	3.06 (77.7)	3.19 (81.0)	2.38 (60.5)	2.13 (54.1)

1. For complete dimensions see applicable Military Specification.
2. Metric dimensions (mm) are indicated in parentheses.

GR2000 AND RP2000 Series Fittings



Conduit &
Accessories

Glenair is qualified for the following GR2000 and RP2000 series fittings. Consult factory for drawings and specifications.

NAVSEA HANDBOOK S9407-AB-HBK-010	NAVSEA HANDBOOK 0967-LP-283-5010
GR2120-X-XX-EMXX-XX	GR2120-X-X-X-XXSN
GR2121-XXSM	GR2121-XXSN
GR2122-XXXSM (Style A)	GR2122-XXXSN (Style A)
GR2122-XXXESM (Style B)	GR2122-XXXESN (Style B)
GR2123-X-XX-EMXX	GR2123-X-X-XXSN
GR2124-X-EMXX-XX	GR2124-X-X-XXSN
GR2125-X-EMXX-XX	GR2125-X-X-XXSN
GR2126-EMXX	GR2126-XX
GR2127-EMXX	GR2127-XX
GR2128-EMXX	GR2128-XXSM
GR2129-EMXX	GR2129-XX
RP2100-EMXX-T(S) Telescoping/Short	RP2100-GXX-T(S)
RP2110-EMXX-T(S) Telescoping/Short	RP2110-GXX-T(S)
RP2120-EMXX-T(S) Telescoping/Short	RP2120-GXX-T(S)
RP2130-EMXX	RP2130-GXX
RP2140-EMXX	RP2140-GXX
RP2141-EMXX	RP2141-GXX
RP2200-EMXX	RP2200-GXX
RP2210-EMXX	RP2210-GXX
RP2311-XX-XX-XXSM	RP2311-XX-XX-XXSN
RP2321-XX-XXSM	RP2321-XX-XXSN
RP2330-XX-XX-N (No Letter Steel) SM	RP2330-XX-XX-N (No Letter Steel) SN
RP2340-XX-XX-XXSM	RP2340-XX-XX-XXSN
RP2350-XX-XX-XX-XSM	RP2350-XX-XX-XX-XSN
RP2360-XX-XX-XXSM	RP2360-XX-XX-XXSN
RP2400-XX-XXSM	RP2400-XX-XXSN
RP2411-XX-XXSM	RP2411-XX-XXSN
RP2420-XX-XXSM	RP2420-XX-XXSN
RP2430-XXSM	RP2430-XXSN
RP2431-XXSM	RP2431-XXSN
RP2440-XXSM	RP2440-XXSN
RP2500-XXSM	RP2500-XXSN
RP2610-XXSM	RP2610-XXSN
RP2620-XXSM	RP2620-XXSN
SM = Electroless Nickel Plating/Mild Steel	SN = Cadmium over Electroless Nickel/Mild Steel

Every Picture Tells a Story



This One Speaks Volumes

Glenair is in the business of solving even the most complex interconnect design problems. That's why we've built our conduit product line to take advantage of our forty years of experience in harness assembly and interconnect packaging.

We know that your problem isn't solved when the connector and wire are selected. The real work starts with the packaging of the key components for actual use. Glenair is ready with

wire protection solutions that include plastic convoluted tubing, metal-core conduit, jacketing and metal or fabric overbraiding. We also produce a line of robust composite junction boxes, which add new design options to traditional conduit wire protection assemblies.

At Glenair, we're ready to go with both the individual technologies, as well as the most innovative and effective packaging solutions available today. Now *that's* a story worth telling.



1211 Air Way
Glendale, California 91201-2497
Telephone: 818-247-6000 · Facsimilie: 818-500-9912 · EMail: sales@glenair.com

United States · United Kingdom · Germany · Nordic · France · Spain · Italy

www.glenair.com

Please Note: SAE Aerospace has assumed control of the M85049 specification for cylindrical connector backshells and accessories.

All existing M85049 specification documents referenced in this index are now superseded by the new AS85049 standard. For convenience in ordering however, basic part numbering for these components still utilize the familiar M85049 prefix.

Several new specification slash sheets have been added to this index since the last published version. The following new products will be available just as soon as the formal SAE qualification process is completed.

AS85049/103	Straight, Composite, Strain-Relief EMI/RFI Backshell
AS85049/104	45°, Composite, Strain-Relief EMI/RFI Backshell
AS85049/105	90°, Composite, Strain-Relief EMI/RFI Backshell
AS85049/109	Straight, EMI/RFI Shield Sock AS5049 Fig. 4
AS85049/111	90°, EMI/RFI Shield Sock AS5049 Fig. 4
AS85049/112	Straight, EMI/RFI Shield Sock AS5049 Fig. 2
AS85049/114	90°, EMI/RFI Shield Sock AS5049 Fig. 2
AS85049/115	Straight, EMI/RFI Shield Sock AS5049 Fig. 3
AS85049/117	90°, EMI/RFI Shield Sock AS5049 Fig. 3
AS85049/118	Straight, Strain-Relief, Full-Radius Entry AS5049 Fig. 4
AS85049/120	90°, Strain-Relief, Full-Radius Entry AS5049 Fig. 4
AS85049/121	Straight, Strain-Relief, Full-Radius Entry AS5049 Fig. 2
AS85049/123	90°, Strain-Relief, Full-Radius Entry AS5049 Fig. 2
AS85049/124	Straight, Strain-Relief, Full-Radius Entry AS5049 Fig. 3
AS85049/126	90°, Strain-Relief, Full-Radius Entry AS5049 Fig. 3
AS85049/127	Bushing Strip for AS85049 Clamps
AS85049/128	Band, Shield Termination
AS85049/130	Square Flange Gasket
AS85049/131	Straight, Fiber Optic Backshell for AS5590/1 Connector
AS85049/132	45°, Fiber Optic Backshell for AS5590/1 Connector
AS85049/133	90°, Fiber Optic Backshell for AS5590/1 Connector



Part Number Index

Military Specification	Superceeding Part Number	Glenair's Commercial Catalog P/N	Description	Connector Interface or Designator (Below)	Page No.
GP2000		**	NAVSEA Series GP2000 Fittings	—	71-41
RP2000		**	NAVSEA Series RP2000 Fittings	—	71-41
MS3057A	M85049/41	620-053 Style A	Str. Strain Relief	****	62-13
MS3057B	M85049/1	620-053 Style B	Str. Strain Relief	****	62-9
MS3057C	M85049/2	620-053 Style C	Str. Strain Relief	****	62-10
MS3057D	M85049/42	620-053 Style H	Str. Strain Relief	****	62-14
MS3105		650BS001	Stowage Receptacle	MIL-DTL-5015	65-2
MS3115		650DS001	Stowage Receptacle	MIL-DTL--26482	65-3
MS3152	M85049/53	450AS001	Str. Qwik-Ty® Strain Relief	A	45-4*
MS3153	M85049/54	450AB001	45° Qwik-Ty® Strain Relief	A	45-4*
MS3154	M85049/55	450AA001	90° Qwik-Ty® Strain Relief	A	45-4*
MS3158	M85049/60-1	310AS001	Shrink Boot Adapter	A	31-4
MS3180		660-008	Protective Cover, Plug	MIL-DTL-26482	66-2
MS3181		660-009	Protective Cover, Recept.	MIL-DTL-26482	66-2
MS3184	M85049/34	**	Adapter	D	32-3*
MS3186		**	Jam Nut	Various	68-2
MS3188A	M85049/8	390AA001	90° EMI/RFI Environmental Backshell	A	39-10
MS3188B	M85049/9	370AA001	90° Environmental Backshell	A	37-22
MS3188C	M85049/24	380AA001	90° EMI/RFI Non-Environmental Backshell	A	38-8
MS3189A	M85049/6	390AB001	45° EMI/RFI Environmental Backshell	A	39-8
MS3189B	M85049/7	370AB001	45° Environmental Backshell	A	37-20
MS3189C	M85049/23	380AB001	45° EMI/RFI Non-Environmental Backshell	A	38-6
MS3415	M85049/43	620AB047	45° Strain Relief	A	62-15*
MS3416E	M85049/31	610AS011	E Nut	A	61-7
MS3416G	M85049/60-2G	310AS002	Shrink Boot Adapter	A	31-5
MS3417	M85049/52-1	620AS046	Str. Strain Relief	A	62-22
MS3418	M85049/51-1	620AA046	90° Strain Relief	A	62-20
MS3419	M85049/26-1	440AS063	Crimp Ring Adapter	A	44-3
MS3420***		**	Telescoping Bushing	—	68-4
MS3437A	M85049/10	390AS001	Str. EMI/RFI Environmental Backshell	A	39-12
MS3437B	M85049/11	370AS001	Str. Environmental Backshell	A	37-24
MS3437C	M85049/25	380AS001	Str. EMI/RFI Non-Environmental Backshell	A	38-10
MS3480		TG38	Connector Wrench	MIL-DTL-5015 & MIL-DTL-83723 Ser. 2	60-2
MS3481		TG39	Connector Wrench	MIL-DTL-26482 Series 1 and 2, MIL-C-83723 Series I, and NAS 1599	60-3
MS3482		TG61	Connector Wrench	MIL-C-81511 Series 1 and 3	60-4
MS17349		660-007	Protective Cover, Recept.	MIL-C-22992	66-3
MS17350		660-006	Protective Cover, Plug	MIL-C-22992	66-3
MS20047	MS27502	660-013	Protective Cover, Recept.	MIL-DTL-38999 Series I	66-5*
MS20048	MS27501	660-012	Protective Cover, Plug	MIL-DTL-38999 Series I	66-5*
M24758/1		**	Flexible Weatherproof EMI-EMP Conduit	—	71-2
M24758/2		**	Str. Conduit Fitting for M24758/9 thru /19	—	71-3
M24758/3		**	45° Conduit Fitting for M24758/9 thru /19	—	71-4
M24758/4		**	90° Conduit Fitting for M24758/9 thru /19	—	71-5
M24758/5		**	Conduit-to-Panel Fitting	—	71-6
M24758/6		**	Conduit-to-Threaded Pipe Fitting	—	71-7
M24758/7		**	Conduit-to-Stuffing Tube	—	71-8

LEGEND		BACKSHELL CONNECTOR DESIGNATORS					
		DESIG.	SPEC.	SERIES	DESIG.	SPEC.	SERIES
*	Page Number of Superceeding Part Number	A	MIL-DTL-5015	MS3400	A	PATT 602	G MIL-C-28840
**	Consult Factory		MIL-DTL-26482	2	B	MIL-DTL-5015	H MIL-DTL-38999 III & IV
***	Distributed by Glenair		AS81703	3	C	MIL-C-22992	MS173XX EN3645
****	MS "V" Thread Gen'l Duty "A" End Bell		MIL-DTL-83723	I & III	D	MIL-DTL-26482	1 J MIL-C-81511 1, 2, 3 & 4
			40M39569		E	MIL-DTL-26500	Aluminum VG95329
			DEF 5326-3		F	MIL-DTL-38999	I & II K MIL-DTL-83723 II
			EN 2997, 3646			40M38277	
			ESC 10, 11			PAN 6433-1	
			LN 29504			PATT 614	
			NFC93422	HE302		PATT 616	
			PAN 6432-1, -2			NFC93422	HE308, 9

Part Number Index



Part Number
Index

Military Specification	Superceeding Part Number	Glenair's Commercial Catalog P/N	Description	Connector Interface or Designator (Below)	Page No.
M24758/8		**	Conduit-to-Conduit Fitting	—	71-11
M24758/9		**	Conduit Adapter	B	71-12
M24758/10		**	Conduit Adapter	Triaxial Connectors	71-14
M24758/11		**	Conduit Adapter	Coaxial Connectors	71-16
M24758/12		**	Conduit Adapter	D	71-18
M24758/13		**	Conduit Adapter	A	71-20
M24758/14		**	Conduit Adapter	—	71-22
M24758/15		**	Conduit Adapter	MIL-C-24235 Stuffing Tube	71-24
M24758/16		**	Conduit Adapter for Miscellaneous Thread	—	71-26
M24758/17		**	Conduit Adapter for Tapered Pipe Thread	—	71-28
M24758/18		**	Conduit Adapter for Str. Pipe Thread	—	71-29
M24758/19		**	Conduit Adapter for Panel Termination	—	71-30
MS25042		660-004	Protective Cover, Plug	MIL-DTL-5015	66-4
MS25043		660-005	Protective Cover, Recept.	MIL-DTL-5015	66-4
MS27291		620ES050	Str. Strain Relief	E	62-2
MS27292	M83723/59-1	660-021	Protective Cover, Plug	MIL-DTL-83723 Series III Thd	66-10
MS27293	M83723/59-2	660-019	Protective Cover, Plug	MIL-DTL-83723 Series III Bay.	66-11
MS27294	M83723/60-1	660-022	Protective Cover, Recept.	MIL-DTL-83723 Series III Thd	66-10
MS27295	M83723/60-2	660-020	Protective Cover, Recept.	MIL-DTL-83723 Series III Bay.	66-11
MS27296	M83723/61-1	650ES001	Stowage Receptacle, Threaded	MIL-DTL-26500 Thd and MIL-C-83723 Series III Thd	65-11
MS27297	M83723/61-2	650ES002	Stowage Receptacle, Bayonet	MIL-DTL-26500 Bay. and MIL-DTL-83723 Series III Bay.	65-11
MS27342-2	M85049/49-2	**	Str. Strain Relief	F	62-19*
MS27352	MS27510	660-014	Protective Cover, Plug	MIL-DTL-38999 Series II	66-6*
MS27353	MS27511	660-015	Protective Cover, Recept.	MIL-DTL-38999 Series II	66-6*
MS27485	M85049/58	**	Potting Boot Adapter	F	30-2*
MS27501		660-012	Protective Cover, Plug	MIL-DTL-38999 Series I	66-5
MS27502		660-013	Protective Cover, Recept.	MIL-DTL-38999 Series I	66-5
MS27506	M85049/49-2	620FS054	Str. Strain Relief	F	62-19*
MS27507	M85049/47	620FA012	90° Strain Relief	F	62-18
MS27510		660-014	Protective Cover, Plug	MIL-DTL-38999 Series II	66-6
MS27511		660-015	Protective Cover, Recept.	MIL-DTL-38999 Series II	66-6
MS27512	MS3186	**	Jam Nut	MIL-DTL-38999 Series II	68-2*
MS27514	MS3186	**	Jam Nut	MIL-DTL-38999 Series I	68-2*
MS27558		**	90° Strain Relief	E	62-3
MS27559		**	90° Strain Relief	E	62-4
MS27668	M85049/56	450FS001	Str. Qwik-Ty® Strain Relief	F	45-5*
MS27669	M85049/57	450FB001	45° Qwik-Ty® Strain Relief	F	45-5*
MS27670	M85049/63	450FA001	90° Qwik-Ty® Strain Relief	F	45-5*
MS27741		410-003	Tag Ring	—	40-2
M28840/1		620GS051	Str. Strain Relief	G	62-5
M28840/2		620GA051	90° Strain Relief	G	62-6
M28840/3		620GA051	45° Strain Relief	G	62-7
M28840/4		**	Flexible Metal Core Conduit	—	71-31
M28840/5		**	EMI/EMP Conduit Backshell	G	71-32
M28840/6 A		**	Str. EMI/RFI Environmental Backshell	G	39-2

LEGEND	
*	Page Number of Superceeding Part Number
**	Consult Factory
***	Distributed by Glenair
****	MS "V" Thread Gen'l Duty "A" End Bell

BACKSHELL CONNECTOR DESIGNATORS					
DESIG.	SPEC.	SERIES	DESIG.	SPEC.	SERIES
A	MIL-DTL-5015	MS3400	A	PATT 602	G MIL-C-28840
	MIL-DTL-26482	2	B	MIL-DTL-5015	H MIL-DTL-38999 III & IV
	AS81703	3	C	MIL-C-22992	MS173XX EN3645
	MIL-DTL-83723	I & III	D	MIL-DTL-26482	1 J MIL-C-81511 1, 2, 3 & 4
	40M39569		E	MIL-DTL-26500	Aluminum VG95329
	DEF 5326-3		F	MIL-DTL-38999	I & II K MIL-DTL-83723 II
	EN 2997, 3646			40M38277	
	ESC 10, 11			PAN 6433-1	
	LN 29504			PATT 614	
	NFC93422	HE302		PATT 616	
	PAN 6432-1, -2			NFC93422	HE308, 9

© 2005 Glenair, Inc. CAGE Code 06324 Printed in U.S.A.

GLENAIR, INC. • 1211 AIR WAY • GLENDALE, CA 91201-2497 • 818-247-6000 • FAX 818-500-9912
www.glenair.com A-3 E-Mail: sales@glenair.com



Part Number Index

Military Specification	Superceeding Part Number	Glenair's Commercial Catalog P/N	Description	Connector Interface or Designator (Below)	Page No.
M28840/6	B	**	Str. Environmental Backshell	G	37-2
M28840/7		650GS001	Stowage Receptacle	MIL-C-28840	65-4
M28840/8	A	**	90° Split EMI/RFI Environmental Backshell	G	39-3
M28840/8	B	**	90° Environmental Backshell	G	37-3
M28840/9	A	**	45° Split EMI/RFI Environmental Backshell	G	39-4
M28840/9	B	**	45° Environmental Backshell	G	37-4
M28840/13		660-010	Protective Cover, Recept.	MIL-C-28840	66-7
M28840/15		660-011	Protective Cover, Plug	MIL-C-28840	66-7
M28840/22		**	Conduit Bushing	—	71-35
M28840/23		**	E Nut	G	61-2
M28840/24		**	Gasket	MIL-C-28840	68-5
M28840/25		**	90° EMI Adapters	MIL-C-28840	71-36
M28840/27		**	45° EMI Adapters	MIL-C-28840	71-38
M28840/30		**	Conduit Union	—	71-40
M29504/04		181-002	Fiber Optic Pin Terminus	—	68-6
M29504/05		181-001	Fiber Optic Socket Terminus	—	68-7
M38999/1	M85049/27	610FS011	E Nut	F	61-6*
M38999/2	M85049/62	310FS001	Shrink Boot Adapter	F	31-6*
M38999/3	M85049/33-2	440FS063	Crimp Ring Adapter	F	44-4*
M38999/4	M85049/30	400-001	Tag Ring Adapter	F	40-3*
M38999/5	M85049/17	390FS012	Str. EMI/RFI Environmental Backshell	F	39-16*
M38999/6	M85049/29	360FS002	Non-Env. Strain Relief Backshell	F	36-5*
M38999/7	M85049/36	380FS008	Str. EMI/RFI Non-Environmental Backshell	F	38-14*
M38999/8	M85049/37	380FD007	90° EMI/RFI Non-Environmental Backshell	F	38-15*
M38999/9		650FS001	Stowage Receptacle	MIL-DTL-38999 Series I	65-5
M38999/10		650FS002	Stowage Receptacle	MIL-DTL-38999 Series II	65-6
D38999/22		650HS010	Stowage Receptacle	MIL-DTL-38999 Series III	65-7
D38999/28		**	Jam Nut	MIL-DTL-38999 Series III and IV	68-8
D38999/32		660-023	Protective Cover, Plug, Composite	MIL-DTL-38999 Series III	66-8
D38999/33		660-024	Protective Cover, Recept., Composite	MIL-DTL-38999 Series III	66-8
D38999/50		650HS007	Stowage Receptacle	MIL-DTL-38999 Series IV	65-8
M81511/13		620JS001	Str. Strain Relief	J	62-8
M81511/14 (A,B)	390JS012		Str. RFI Environmental	J	39-6
M81511/14 (C,D)	380JS008		Str. RFI Non-Environmental Backshell	J	38-2
M81511/16		610JS012	E Nut	J	61-3
M81511/17		660-017	Protective Cover, Plug	MIL-DTL-81511 Series 2	66-9
M81511/18		660-018	Protective Cover, Recept.	MIL-DTL-81511 Series 1 and 2	66-9
M81511/19		650JS002	Stowage Receptacle	MIL-DTL-81511 Series 2	65-9
M81511/29		660-016	Protective Cover, Plug	MIL-DTL-81511 Series 1	66-9
M81511/30		650JS001	Stowage Receptacle	MIL-DTL-81511 Series 1	65-10
M83538/9		**	Adapter	MIL-DTL-83538/4	32-2
M83723/15A	M85049/51-1	620AA046	90° Strain Relief	A	62-20
M83723/15N	M85049/31	610AS011	E Nut	A	61-7
M83723/15S	M85049/52-1	620AS046	Str. Strain Relief	A	62-22
M83723/16M	M85049/60-2G	310AS002	Shrink Boot Adapter	A	31-5*
M83723/27M		310KS002	Shrink Boot Adapter	K	31-2
M83723/35A		**	90° Non-Env. Strain Relief Backshell	K	36-2

LEGEND	
*	Page Number of Superceeding Part Number
**	Consult Factory
***	Distributed by Glenair
****	MS "V" Thread Gen'l Duty "A" End Bell

BACKSHELL CONNECTOR DESIGNATORS								
DESIG.	SPEC.	SERIES	DESIG.	SPEC.	SERIES	DESIG.	SPEC.	SERIES
A	MIL-DTL-5015	MS3400	A	PATT 602		G	MIL-C-28840	
	MIL-DTL-26482	2	B	MIL-DTL-5015	MS3100	H	MIL-DTL-38999	III & IV
	AS81703	3	C	MIL-C-22992	MS173XX		EN3645	
	MIL-DTL-83723	I & III	D	MIL-DTL-26482	1	J	MIL-C-81511	1, 2, 3 & 4
	40M39569		E	MIL-DTL-26500	Aluminum		VG95329	
	DEF 5326-3		F	MIL-DTL-38999	I & II	K	MIL-DTL-83723	II
	EN 2997, 3646			40M38277				
	ESC 10, 11			PAN 6433-1				
	LN 29504			PATT 614				
	NFC93422	HE302		PATT 616				
	PAN 6432-1, -2			NFC93422	HE308, 9			

Part Number Index



Part Number
Index

Military Specification	Superceeding Part Number	Glenair's Commercial Catalog P/N	Description	Connector Interface or Designator (Below)	Page No.
M83723/35N		**	E Nut	K	61-4
M83723/35S		**	Non-Environmental Strain Relief Backshell	K	36-3
M83723/44	MS3181	660-009	Protective Cover, Recept.	MIL-DTL-26482	66-2*
M83723/45	MS3115	650DS001	Stowage Receptacle	MIL-DTL-26482	65-3*
M83723/46	MS3180	660-008	Protective Cover, Plug	MIL-DTL-26482	66-2*
M83723/50A		**	90° Qwik-Ty® Strain Relief	K	45-2
M83723/50B		**	45° Qwik-Ty® Strain Relief	K	45-2
M83723/50R		**	Str. Qwik-Ty® Strain Relief	K	45-2
M83723/59-1		660-021	Protective Cover, Plug	MIL-DTL-83723 Series III Thd	66-10
M83723/59-2		660-019	Protective Cover, Plug	MIL-DTL-83723 Series III Bay.	66-11
M83723/60-1		660-022	Protective Cover, Recept.	MIL-DTL-83723 Series III Thd	66-10
M83723/60-2		660-020	Protective Cover, Recept.	MIL-DTL-83723 Series III Bay.	66-11
M83723/61-1		650ES001	Stowage Receptacle, Threaded	MIL-DTL-26500 Thd and MIL-DTL-83723 Series III Thd	65-11
M83723/61-2		650ES002	Stowage Receptacle, Bayonet	MIL-DTL-26500 Bay. and MIL-DTL-83723 Series III Bay.	65-11
M83723/70		**	Receptacle Adapter	MIL-DTL-83723 Series III	68-9
M83733/15	M85049/28	**	EMI Rectangular Backshell	MIL-DTL-83733	50-2
M83733/16	M85049/44	**	Rectangular Strain Relief Backshell	MIL-DTL-83733	50-3
AS85049/1		620-053 Style B	Strain Relief	****	62-9
AS85049/2		620-053 Style C	Strain Relief	****	62-10
AS85049/3 1		**	Str. Environmental Backshell	C	37-5
AS85049/3 2		**	Str. Environmental Backshell	C	37-6
AS85049/3 3		**	Str. Environmental Backshell	C	37-7
AS85049/4 1		**	Str. Environmental Backshell	C	37-8
AS85049/4 2		**	Str. Environmental Backshell	C	37-10
AS85049/4 3		**	Str. Environmental Backshell	C	37-12
AS85049/5 1		**	Str. Environmental Backshell	C	37-14
AS85049/5 2		**	Str. Environmental Backshell	C	37-16
AS85049/5 3		**	Str. Environmental Backshell	C	37-18
AS85049/6		390AB001	45° EMI/RFI Environmental Backshell	A	39-8
AS85049/7		370AB001	45° Environmental Backshell	A	37-20
AS85049/8		390AA001	90° EMI/RFI Environmental Backshell	A	39-10
AS85049/9		370AA001	90° Environmental Backshell	A	37-22
AS85049/10		390AS001	Str. EMI/RFI Environmental Backshell	A	39-12
AS85049/11		370AS001	Str. Environmental Backshell	A	37-24
AS85049/14S		**	E Nut, Self Locking	H	61-5
AS85049/15G		**	45° Qwik-Ty® Strain Relief, Self-Lock. w/ Ground Lug	H	45-3
AS85049/15S		**	45° Qwik-Ty® Strain Relief, Self-Locking	H	45-3
AS85049/16G		**	90° Qwik-Ty® Strain Relief, Self-Lock. w/ Ground Lug	H	45-3
AS85049/16S		**	90° Qwik-Ty® Strain Relief, Self-Locking	H	45-3
AS85049/17		390FS012	Str. EMI/RFI Environmental Backshell	F	39-16
AS85049/18		390HS011	Str. EMI/RFI Environmental Backshell	H	39-17
AS85049/19		380HS007	Str. EMI/RFI Non-Environmental Backshell	H	38-5
AS85049/20		440FS063	Crimp Ring Adapter	H	44-2

LEGEND	
*	Page Number of Superceeding Part Number
**	Consult Factory
***	Distributed by Glenair
****	MS "V" Thread Gen'l Duty "A" End Bell

BACKSHELL CONNECTOR DESIGNATORS					
DESIG.	SPEC.	SERIES	DESIG.	SPEC.	SERIES
A	MIL-DTL-5015	MS3400	A	PATT 602	G MIL-C-28840
	MIL-DTL-26482	2	B	MIL-DTL-5015	H MIL-DTL-38999 III & IV
	AS81703	3	C	MIL-C-22992	MS173XX EN3645
	MIL-DTL-83723	I & III	D	MIL-DTL-26482	1 J MIL-C-81511 1, 2, 3 & 4
	40M39569		E	MIL-DTL-26500	Aluminum VG95329
	DEF 5326-3		F	MIL-DTL-38999	I & II K MIL-DTL-83723 II
	EN 2997, 3646			40M38277	
	ESC 10, 11			PAN 6433-1	
	LN 29504			PATT 614	
	NFC93422	HE302		PATT 616	
	PAN 6432-1, -2			NFC93422	HE308, 9



Part Number Index

Military Specification	Superceding Part Number	Glenair's Commercial Catalog P/N	Description	Connector Interface or Designator (Below)	Page No.
AS85049/21		360HS002	Non-Environmental Strain Relief Backshell	H	36-4
AS85049/23		380AB001	45° EMI/RFI Non-Environmental Backshell	A	38-6
AS85049/24		380AA001	90° EMI/RFI Non-Environmental Backshell	A	38-8
AS85049/25		380AS001	Str. EMI/RFI Non-Environmental Backshell	A	38-10
AS85049/26-1		440AS063	Crimp Ring Adapter	A	44-3
AS85049/26-2		**	Crimp Ring	—	44-3
AS85049/26-3		440AS063	Crimp Ring Adapter with Crimp Ring	A	44-3
AS85049/27		610FS011	E Nut	F	61-6
AS85049/27S		**	E Nut, Self Locking	F	61-6
AS85049/28		**	EMI Rectangular Backshell	MIL-DTL-83733	50-2
AS85049/29		360FS002	Non-Environmental Strain Relief Backshell	F	36-5
AS85049/30		400-001	Tag Ring Adapter	F	40-3
AS85049/31		610AS011	E Nut	A	61-7
AS85049/31S		**	E Nut, Self Locking	A	61-7
AS85049/32-1		**	Adapter, Non-Env., RFI, 90°	F	68-10
AS85049/32-2		**	Adapter	—	68-11
AS85049/33-1		**	Adapter, Non-Env., RFI, Str.	F	68-12
AS85049/33-2		440FS063	Crimp Ring Adapter	F	44-4
AS85049/34		**	Adapter	D (MS3114 and MS3124 Only)	32-3
AS85049/36		380FS008	Str. EMI/RFI Non-Environmental Backshell	F	38-14
AS85049/37		380FD007	90° EMI/RFI Non-Environmental Backshell	F	38-15
AS85049/38		620HS011	Str. Strain Relief	H	62-11
AS85049/38S		620HS048	Str. Strain Relief, Self-Locking	H	62-11
AS85049/38SS	**		Str. Strain Relief, Self-Locking, St. Steel	H	62-11
AS85049/39		620HA011	90° Strain Relief	H	62-12
AS85049/39S		620HA048	90° Strain Relief, Self-Locking	H	62-12
AS85049/39SS	**		90° Strain Relief, Self-Locking, St. Steel	H	62-12
AS85049/41		620-053 Style A	Str. Strain Relief	****	62-13
AS85049/42		620-053 Style H	Str. Strain Relief	****	62-14
AS85049/43		620AB047	45° Strain Relief	A	62-15
AS85049/44		**	Rectangular Strain Relief Backshell	MIL-DTL83733	50-3
AS85049/45		**	Str. Strain Relief	F	62-16
AS85049/46		**	90° Strain Relief	F	62-17
AS85049/47		620FA012	90° Strain Relief	F	62-18
AS85049/47S		620FA048	90° Strain Relief, Self-Locking	F	62-18
AS85049/47SS	620FA048Z1		90° Strain Relief, Self-Locking (Steel)	F	62-18
AS85049/48-1****			Rectangular Strain Relief Backshell	MIL-DTL-24308	50-4
AS85049/48-2****			Rectangular Strain Relief Backshell	MIL-DTL-24308	50-5
AS85049/48-3****			Rectangular Strain Relief Backshell	MIL-DTL-24308	50-6
AS85049/49-2		620FS012	Str. Strain Relief	F	62-19
AS85049/49-2S	620FS048		Str. Strain Relief, Self-Locking	F	62-19
AS85049/49-2SS	620FS048Z1		Str. Strain Relief, Self-Locking (Steel)	F	62-19
AS85049/50****	**		90° Rectangular Strain Relief Backshell	MIL-DTL-24308	50-7
AS85049/51-1		620AA046	90° Strain Relief	A	62-20
AS85049/51S		620AA048	90° Strain Relief, Self-Locking	A	62-20
AS85049/52-1		620AS046	Str. Strain Relief	A	62-22
AS85049/52S		620AS048	Str. Strain Relief, Self-Locking	A	62-22

LEGEND	
*	Page Number of Superceding Part Number
**	Consult Factory
***	Distributed by Glenair
****	MS "V" Thread Gen'l Duty "A" End Bell

BACKSHELL CONNECTOR DESIGNATORS								
DESIG.	SPEC.	SERIES	DESIG.	SPEC.	SERIES	DESIG.	SPEC.	SERIES
A	MIL-DTL-5015	MS3400	A	PATT 602		G	MIL-C-28840	
	MIL-DTL-26482	2	B	MIL-DTL-5015	MS3100	H	MIL-DTL-38999	III & IV
	AS81703	3	C	MIL-C-22992	MS173XX		EN3645	
	MIL-DTL-83723	I & III	D	MIL-DTL-26482	1	J	MIL-C-81511	1, 2, 3 & 4
	40M39569		E	MIL-DTL-26500	Aluminum		VG95329	
	DEF 5326-3		F	MIL-DTL-38999	I & II	K	MIL-DTL-83723	II
	EN 2997, 3646			40M38277				
	ESC 10, 11			PAN 6433-1				
	LN 29504			PATT 614				
	NFC93422	HE302		PATT 616				
	PAN 6432-1, -2			NFC93422	HE308, 9			

Part Number Index



Part Number
Index

Military Specification	Superceeding Part Number	Glenair's Commercial Catalog P/N	Description	Connector Interface or Designator (Below)	Page No.
AS85049/53	M85049/52	450AS001	Str. Qwik-Ty® Strain Relief	A	45-4
AS85049/54	M85049/43	450AB001	45° Qwik-Ty® Strain Relief	A	45-4
AS85049/55	M85049/51	450AA001	90° Qwik-Ty® Strain Relief	A	45-4
AS85049/55G	M85049/51S	**	90° Qwik-Ty® Str. Rel., Self Lock., Gr. Lug	A	45-4
AS85049/55S	M85049/51S	**	90° Qwik-Ty® Strain Relief, Self-Locking	A	45-4
AS85049/56		450FS001	Str. Qwik-Ty® Strain Relief	F	45-5
AS85049/57		450FB001	45° Qwik-Ty® Strain Relief	F	45-5
AS85049/57G		**	45° Qwik-Ty® Str. Rel., Self Lock., Gr. Lug	F	45-5
AS85049/57S		**	45° Qwik-Ty® Strain Relief, Self-Locking	F	45-5
AS85049/58		**	Potting Boot Ring	F	30-2
AS85049/59		310CS002	Shrink Boot Adapter	C	31-3
AS85049/60-1		310AS001	Shrink Boot Adapter	A	31-4
AS85049/60-2G	310AS002	Shrink Boot Adapter	A	31-5	
AS85049/61		**	Potting Boot Ring	MIL-DTL-27599	30-3
AS85049/62		310FS001	Shrink Boot Adapter	F	31-6
AS85049/63		450FA001	90° Qwik-Ty® Strain Relief	F	45-5
AS85049/63G		**	90° Qwik-Ty® Str. Rel., Self Lock., Gr. Lug	F	45-5
AS85049/63S		**	90° Qwik-Ty® Strain Relief, Self Locking	F	45-5
AS85049/69		310HS001	Shrink Boot Adapter	H	31-7
AS85049/74*** **		Potting Boot	—	68-13	
AS85049/75*** **		Potting Boot	—	68-14	
AS85049/76		390FL011	90° EMI/RFI Environmental Backshell	F	39-18
AS85049/77		390FK011	45° EMI/RFI Environmental Backshell	F	39-19
AS85049/78		390HK011	45° EMI/RFI Environmental Backshell	H	39-20
AS85049/79		390HL011	90° EMI/RFI Environmental Backshell	H	39-21
AS85049/82		440AS069	Str. Banding Backshell	A	44-5
AS85049/83		440AH069	45° Banding Backshell	A	44-5
AS85049/84		440AJ069	90° Banding Backshell	A	44-5
AS85049/85		440FS069	Str. Banding Backshell	F	44-6
AS85049/86		440FH069	45° Banding Backshell	F	44-6
AS85049/87		440FJ069	90° Banding Backshell	F	44-6
AS85049/88		440HS069	Str. Banding Backshell	H	44-8
AS85049/89		440HH069	45° Banding Backshell	H	44-8
AS85049/90		440HJ069	90° Banding Backshell	H	44-8
AS85049/91		620HS042	Str. Strain Relief, Composite Material	H	62-24
AS85049/92		620HA042	90° Strain Relief, Composite Material	H	62-24
AS85049/93		687-207	Banding Split Ring	—	68-15
AS85049/94*** **		Mounting Device, Full Perimeter		Various	68-16
AS85049/95*** **		Mounting Device, 3/4 Perimeter		Various	68-17
AS85049/96*** **		Mounting Device, 1/4 Perimeter		Various	68-18
M85528/1***		**	Mounting Device, Full Perimeter	Various	68-19
M85528/2***		**	Mounting Device, 3/4 Perimeter	Various	68-20
M85528/3***		**	Mounting Device, 1/4 Perimeter	Various	68-18
M90563		660-007	Protective Cover, Receptacle	MIL-C-22992	66-12
M90564		660-007	Protective Cover, Plug	MIL-C-22992	66-12

LEGEND	
*	Page Number of Superceeding Part Number
**	Consult Factory
***	Distributed by Glenair
****	MS "V" Thread Gen'l Duty "A" End Bell

BACKSHELL CONNECTOR DESIGNATORS					
DESIG.	SPEC.	SERIES	DESIG.	SPEC.	SERIES
A	MIL-DTL-5015	MS3400	A	PATT 602	G MIL-C-28840
	MIL-DTL-26482	2	B	MIL-DTL-5015	H MIL-DTL-38999 III & IV
	AS81703	3	C	MIL-C-22992	MS173XX EN3645
	MIL-DTL-83723	I & III	D	MIL-DTL-26482 1	J MIL-C-81511 1, 2, 3 & 4
	40M39569		E	MIL-DTL-26500	Aluminum VG95329
	DEF 5326-3		F	MIL-DTL-38999	I & II K MIL-DTL-83723 II
	EN 2997, 3646			40M38277	
	ESC 10, 11			PAN 6433-1	
	LN 29504			PATT 614	
	NFC93422	HE302		PATT 616	
	PAN 6432-1, -2			NFC93422	HE308, 9

Series 80 "Mighty Mouse" Connectors and Cables

Glenair's "Mighty Mouse" Connectors and cables offer superior environmental performance in an ultraminiature package. Products include miniaturized threaded, quick disconnect and bayonet connectors .

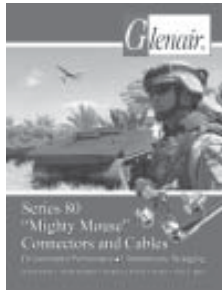

Sav-Con® Connector savers

Glenair's makes a connector saver for every Military Standard circular connector. The low-profile go-betweens are designed to prevent damage to deliverable connectors and extend the life of test cables and harnesses.



Micro-D TwistPin Connectors and Accessories

Glenair offers both Military Standard 83513 Micro-D connectors as well as COTS selections, backshells, mounting hardware and more. Our unique TwistPin contact system offers superior performance.



Geo-Marine® Interconnect Solutions

Our Geo-Marine® product line includes corrosion-free composite junction boxes, harsh environment connectors and cables, Ex Barrier Glands, underwater interconnect assemblies and hydraulic earth bond equipment.



Backshell Assembly Tools, Banding Tools and Accessories

Most interconnect tool suppliers are selling somebody else's ideas, but as you will discover in this catalog, Glenair builds its assembly tools from the ground up. 64 information-packed pages.



Glenair: A World of Interconnect Solutions

Glenair has been the leading manufacturer and supplier of commercial and Military Standard connector accessories since 1956. Building on that foundation, we now offer a dozen, full-spectrum product lines designed to meet every interconnect requirement.

Fiber Optic Interconnect Solutions

Glenair's tactical fiber optic connectors and cables are used in military aerospace applications such as fighter jets and unmanned aerial vehicles. Products include Mil-Dtl-38999 connectors, termini and inspection and test toolkits.



Military Standard Circular Connectors

Military Standard Circular Connectors from Glenair now include hermetic, environmental and filter versions of MIL-C-26482, MIL-C-28840, MIL-DTL-5015, and Mil-DTL-38999 Series I, II, III and IV—many in stock and ready for shipment.

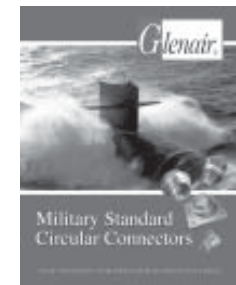

Glenair, Inc.

1211 Air Way · Glendale, California 91201-2497
Telephone: 818-247-6000 · Facsimilie: 818-500-9912
E-mail: sales@glenair.com

United States · United Kingdom · Germany · France · Nordic · Italy · Spain

www.glenair.com

Call Glenair today at 818-247-6000 to order your CD/catalogs; or view our entire product line on the Internet at www.glenair.com and use the literature order form for immediate fulfillment.